

*The*  
AIRCRAFT  
YEAR BOOK

*For 1944*

AIRCRAFT YEAR BOOK FOR 1944

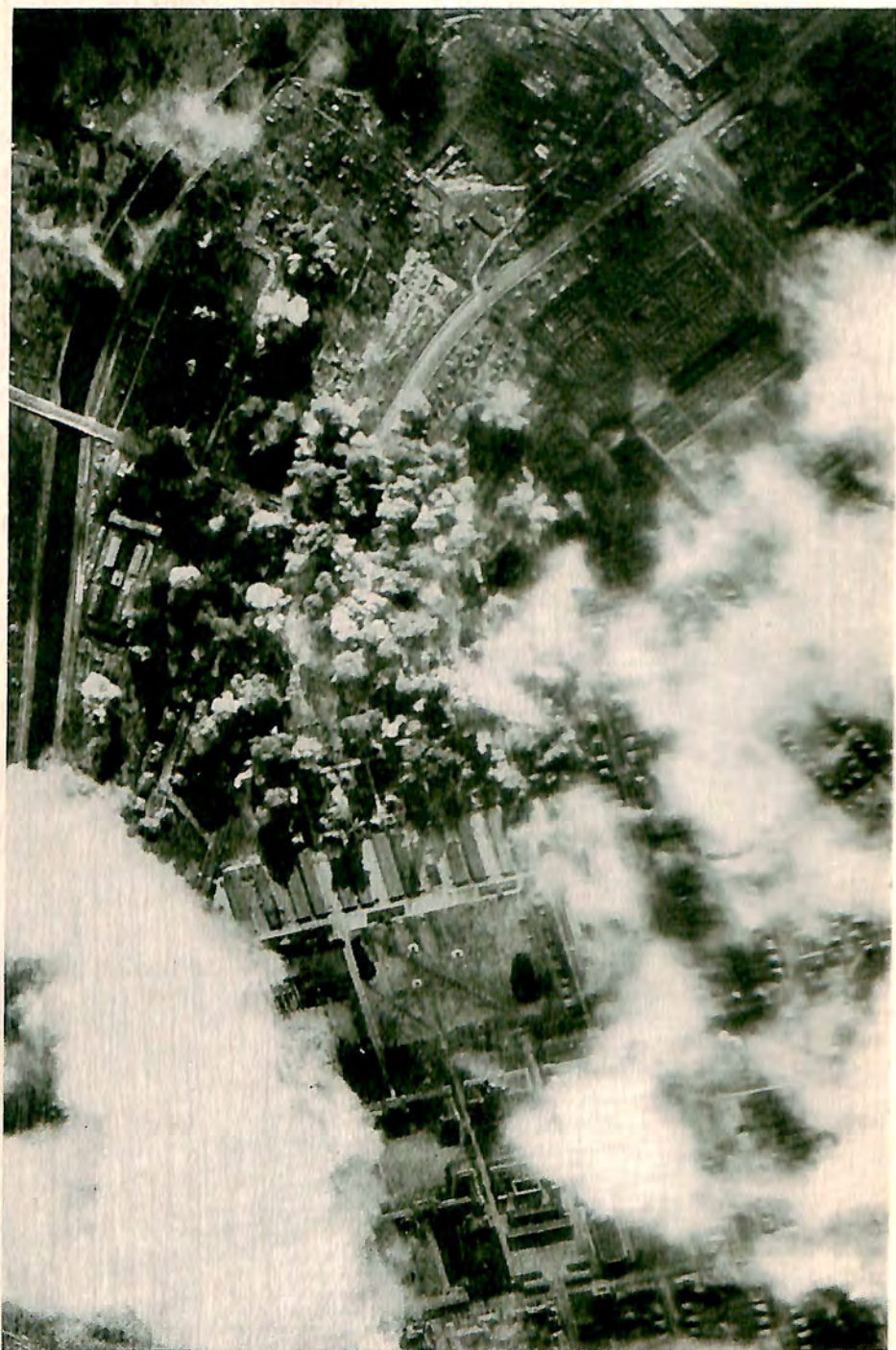



U.S.A.A.F. photo

### OUR BOMBERS REACH BERLIN

One of the targets in Berlin's southwest factory district blasted by the U. S. Army Eighth Air Force during its daylight attack of March 6, 1944, the second in three days.

*The*  
**AIRCRAFT  
YEAR BOOK**

*(Registered U. S. Patent Office)*

*For 1944*

TWENTY-SIXTH ANNUAL EDITION

HOWARD MINGOS

Editor

*Official Publication of*  
Aeronautical Chamber of Commerce  
of America, Inc.



*Published by*

LANCIAR PUBLISHERS, INC.

10 Rockefeller Plaza

New York



Copyright 1944 By  
LANCIAR PUBLISHERS, INC.  
NEW YORK, N. Y.

MANUFACTURED COMPLETE BY  
THE COLONIAL PRESS INC., CLINTON, MASS.

## TABLE OF CONTENTS

CHAPTER	PAGE
I. THE WAR IN THE AIR . . . . .	9
II. THE AMERICAN RECORD . . . . .	29
III. THE U. S. ARMY AIR FORCES . . . . .	49
IV. U. S. NAVAL AVIATION AT WAR . . . . .	91
V. THE CIVIL AIR PATROL . . . . .	123
VI. AIR TRANSPORT IN THE WAR . . . . .	133
VII. AVIATION TRAINING FOR WAR . . . . .	171
VIII. WORK OF THE FEDERAL BUREAUS . . . . .	193
IX. AERONAUTICAL ORGANIZATIONS . . . . .	217
X. NEW THINGS IN THE AIR . . . . .	241
AIRCRAFT DESIGNS . . . . .	242-305
DIRECTORY . . . . .	397
FLYING FACTS AND FIGURES . . . . .	679
INDEX OF ADVERTISERS . . . . .	710
INDEX . . . . .	715



## ILLUSTRATIONS

	PAGE		PAGE
Bombing of Berlin . . . . .		Frontispiece	
Adel Remote Control . . . . .	316	Cessna Bobcat . . . . .	233
Aeronca Grasshopper Liaison . . . . .	243	Civil Aeronautics Administration	
Aeroproducts Propeller . . . . .	318	Air Traffic Control . . . . .	195
Air Attacks		Communications Center . . . . .	201
Blasting German Supplies . . . . .	28	Contact Lights . . . . .	198
Buka . . . . .	99	Civil Air Patrol	
Ferryville . . . . .	11	Cadets . . . . .	125, 181
Formosa . . . . .	77	Coastal Patrol . . . . .	122
Haiphong . . . . .	26	Forest Patrol . . . . .	127
Marshall and Gilbert Islands . . . . .	98	Instruction . . . . .	131
Naples . . . . .	12	Operations Office . . . . .	129
Nauru Island . . . . .	30	Rescue Mission . . . . .	133
Rabaul . . . . .	25, 86	Coast Guard Depth Bomb . . . . .	121
Rangoon . . . . .	73	Consolidated Vultee	
Regensburg . . . . .	53	Catalina . . . . .	119
Rome . . . . .	13, 67	Coronado . . . . .	90
Schweinfurt . . . . .	55	Liberator . . . . .	44, 67, 327
Submarine Sinking . . . . .	95	Vengeance . . . . .	257
Truk . . . . .	8	Crown Fasteners . . . . .	330
Wake Island . . . . .	27, 100	Curtiss-Wright	
Warnemunde . . . . .	212	Commando . . . . .	113, 155, 162, 167
Weiner-Neustadt . . . . .	57	Helldiver . . . . .	36
Aircraft Design Drawings . . . . .	242-304	Propeller Test . . . . .	332
Allison Engine Production . . . . .	307	Seagull . . . . .	97
Alloys Foundry Conveyor . . . . .	320	Warhawk . . . . .	43
Army Air Forces		Davison Protek Plug . . . . .	334
Map . . . . .	48	Death at Rabaul . . . . .	105
Smoke Screen . . . . .	209	Douglas	
Transport . . . . .	134	Cargoliner DC-3 . . . . .	168
Gen. H. H. Arnold . . . . .	51	Dauntless . . . . .	102
Atlantic Convoy . . . . .	10	Havoc . . . . .	237
Beech		Skymaster . . . . .	149
Production . . . . .	215	Skytrain . . . . .	139
Trainer . . . . .	111, 170, 216, 236	Duramold Fuel Tank . . . . .	337
Traveler . . . . .	165	Edo Amphibious Float Gear . . . . .	341
Bell		Gen. Dwight D. Eisenhower and	
Airacobra . . . . .	39, 234	Piper Cub . . . . .	213
Production . . . . .	246	Fairchild	
Bellanca Production . . . . .	238	Cornell Trainer . . . . .	185
Boeing		Forwarder . . . . .	203
Caydet . . . . .	117	Gunner . . . . .	271
Clipper . . . . .	157, 314	Plant . . . . .	231
Flying Fortress . . . . .	31, 45, 46, 81	Production . . . . .	239
Brewster Corsair Production . . . . .	103	Firestone Life Raft . . . . .	344
Major Gen. Simon B. Buckner . . . . .	88	Flight Strip . . . . .	89
Cal-Aero Flight Academy . . . . .	187	Formica Instrument Panels . . . . .	345
Carriers . . . . .	20, 93, 94, 107	Gen. Mark Clark's Piper Cub . . . . .	211

## ILLUSTRATIONS

vii

	PAGE		PAGE
German Attack on Bari . . . . .	70	North American	
B. F. Goodrich Cold Room . . . . .	348	Conveyor Line . . . . .	205
Graphs . . . . . 219, 221, 223, 225, 227, 229		Mitchell . . . . .	33, 60
Grumman		Mustang . . . . .	85
Avenger . . . . . 101, 104, 109		Texan . . . . .	116
Grey Goose . . . . .	110	Northrop Patrol Bomber . . . . .	293
Hellcat . . . . .	32, 106	Paratroopers . . . . . 65, 82, 210	
Widgeon . . . . .	112	Piper Cub Observation . . . . .	240
Hallicrafters Field Radio . . . . .	350	Pratt & Whitney Engines . . . . .	311
Jacobs Engine Production . . . . .	309	Ranger Engines . . . . .	313
Jones, Casey, School of Aero-		Republic Thunderbolt 34, 47, 63, 297	
nautics . . . . .	191	Roosevelt Aviation School . . . . .	189
Kellett Autogiro . . . . .	235	Ryan	
Link Instrument Training . . . . .	175	Exhaust Manifold . . . . .	376
Lockheed		Trainers . . . . . 176, 298	
Assembly Line . . . . .	207	Ryan School of Aeronautics . . . . .	176
Constellation . . . . . 143, 159		Salamaua Peninsula . . . . .	21
Lightning . . . . .	41	Sikorsky Helicopter . . . . .	299
Col. W. R. Lovelace . . . . .	253	Simmonds-Hobson Automatic	
Lycoming Engine Installation . . . . .	310	Engine Control . . . . .	379
Martin		Sperry Automatic Bomb Run . . . . .	382
Assembly Line . . . . .	206	Stewart Technical School . . . . .	192
Marauder . . . . .	42	Taylorcraft Grasshopper Liaison . . . . .	301
Mariner . . . . . 96, 108		Titeflex Ignition Harness . . . . .	389
Mars . . . . .	115	United Air Lines . . . . .	169
Meyers Trainers . . . . .	287	United-Carr Fastener Wire	
Morrison Metal Stitchers . . . . .	377	Harness Clip . . . . .	391
National Advisory Committee		Vought Corsair . . . . .	120
for Aeronautics		Waco Glider . . . . .	306
Propeller . . . . .	35	Western Electric Altitude	
Shock Waves . . . . .	37	Microphone . . . . .	395
Wind Tunnel . . . . .	208	Wright Cyclone Engine . . . . .	315
Wind Tunnel Test . . . . .	114		



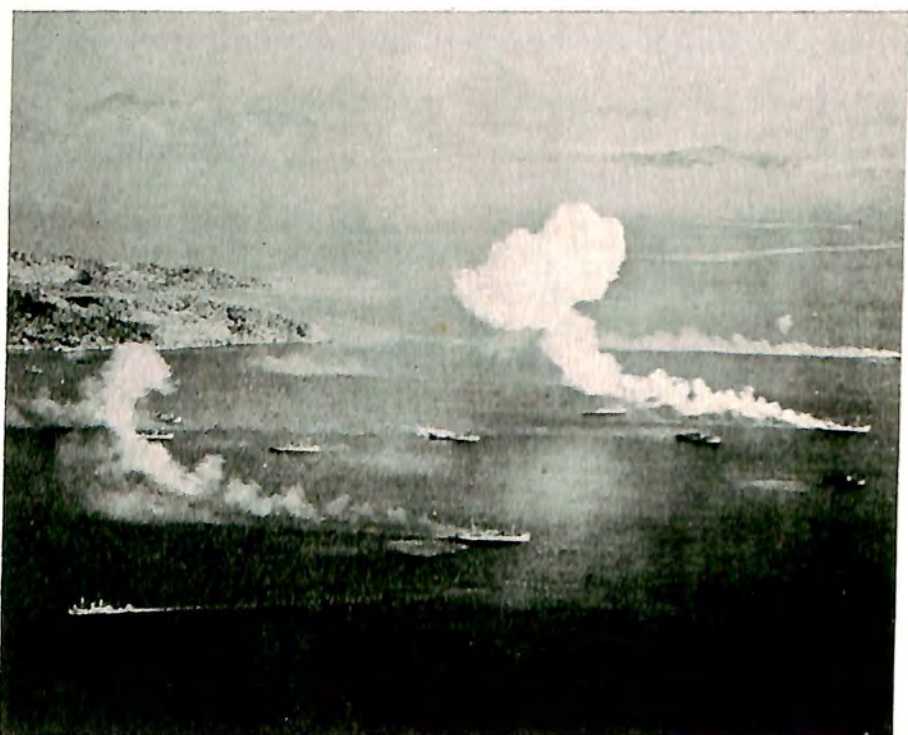

U.S. Navy photo

#### OUR NAVY ATTACKS TRUK

Truk harbor shortly after planes from U. S. Navy carriers commenced their attack during the first raid on the Japanese stronghold on February 16, 1944.

## CHAPTER I

### THE WAR IN THE AIR

**T**HE United States has been at war 28 months as this is written early in April, 1944, and month by month since the Japanese air attack on Pearl Harbor, the air war has been growing to tremendous and significant proportions. Land, sea and air have become of equal importance in all the campaigns. Whole countries have been lost or won by air power used in conjunction with the armies on land and the navies at sea. It is everywhere. Air power is not everything, by any means. Nothing has occurred to prove that a war can be won without armies or navies, particularly world wars. On the other hand, everything that has happened thus far proves conclusively that a battle, a campaign or even a whole war can be lost for want of air power. Every defeat, even the temporary setbacks, sustained by the belligerents on both sides can be traced directly to lack of air force strength in the right place at the right time. As we have been able to put increasingly heavy air force behind our Allied campaigns, both in Europe and in the Pacific, the holocaust that it can cause has become apparent. The ferocious intensity of the Allied air attacks in recent months, if stepped up in both ferocity and intensity on all fronts, will develop absolute control of the air. Then the Allies can blast out relatively clear paths for the surface forces straight into enemy homelands, both German and Jap, and end the war quickly. Everything proves it.

In the early stages of the war, the Axis Powers won all important campaigns by using their dominant air power in the right place at the right time. It let the Germans into France. It blasted a way for them deep into Russia. It helped the Jap armies take Hong Kong, Singapore and Burma; and it surely helped the Japanese Navy on to one easy conquest after another. It was Jap air strength applied in the right place at the right time that drove us out of the Philippines, captured Java and nearly all the islands in the South and Southwest Pacific, including most of New Guinea.

We had only a few planes in the Philippines, and nearly all were smashed by the Japs at the same time that they were wrecking our planes and our fleet at Pearl Harbor. Had we possessed enough of an air force in the Philippines, we could have destroyed Japan's air strength before it came within striking range; and we could have kept our defending forces supplied and fighting even if we could not have prevented the invaders from landing troops. There should have been no fall of Bataan. Maintenance of our supply lines could have prevented it. Control of the air would have stopped the enemy.





U. S. Navy photo

## ATLANTIC CONVOY ESCORT

A huge United Nations convoy plowing through the Atlantic ocean bound for Africa. The convoy was well escorted by sea and air.

The North African campaign was won by Allied control of the air. It was one of the most decisive victories in all history. The Mediterranean was the great prize. The side that won permanent control of it could not lose the war; and it would enhance the chances for final victory many times over. At least, it would give the possessors the advantage of a stalemate. If the Axis had won control, they would have had a clear channel of communications between Europe and Japan; and the United Nations would have been cut off one from another. Alexandria, eastern key to the Mediterranean, the Suez canal, British oil in Iraq and Iran all would have been in Axis hands. Turkey could have been forced into collaboration, with a threat to the Russian flank and the oil of the Caucasus. A drive southward would have struck our great American supply base in Eritrea. Our air ferry and transport route across Africa, thence to the Persian Gulf and Russia, and to India and China, would have been cut off. German and Jap could have joined forces in India. Those were the black prospects during the first six months of 1942. The outlook was as forbidding for the Allies as it was promising for the enemy.

Why did the Axis fail? The answer is that they failed first to get control of the air. They had not profited by the experience of the Italians in Libya in 1940. At that time the Italians had a good air force for their Libyan campaign; but they failed to use it properly. It was under the command of the ground forces, and local commanders used it in small groups to protect local sectors. The British Royal Air Force was small and its planes in North Africa at that time were ob-



solete; yet operating as a mass air force, the R.A.F. knocked the Italians out of the skies.

When the Germans sent their Marshal Rommel and his Afrika Korps into the campaign to help the Italians, they sent a fairly large air force along with it, and the desert war became truly three dimensional. The British, meanwhile, had built up their R.A.F., and when Rommel started pushing the British Eighth Army eastward, the R.A.F., saved it from annihilation. Rommel had three principal weapons with which to help his infantry. He had plenty of tanks, big guns and dive bombers. With these he took the huge British garrison at Tobruk in a day, and kept chasing the British back eastward. It was the R.A.F. that stopped him finally at El Alamein.

There both armies took stock of their positions. The British needed more tanks and more planes. Rommel believed that with his

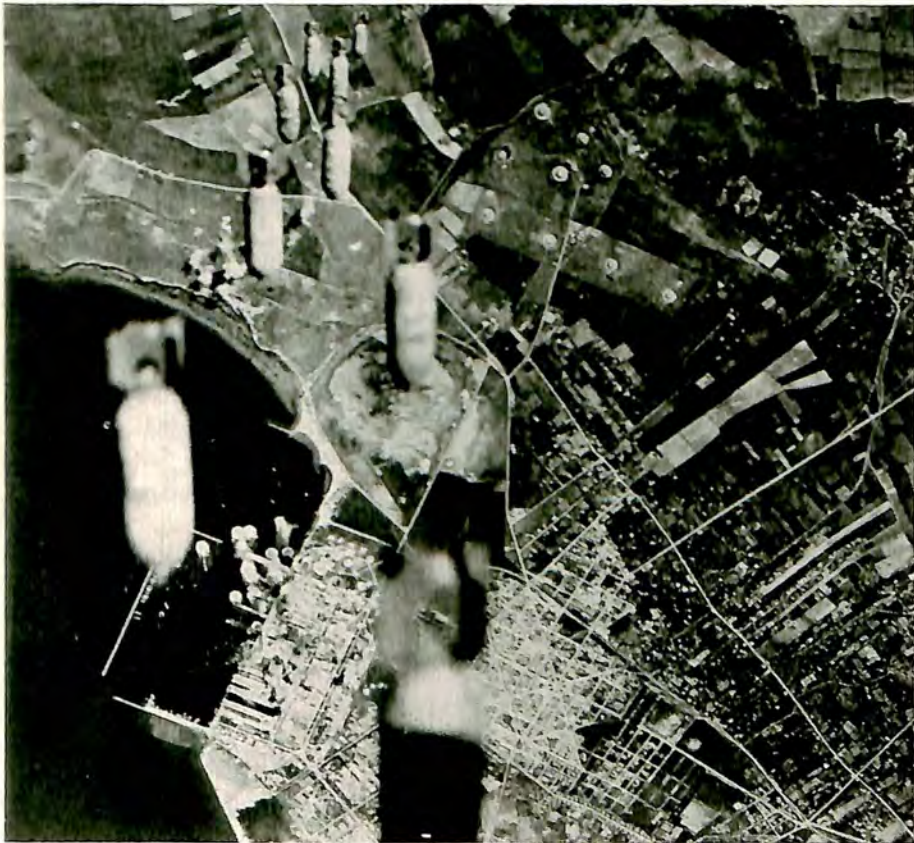

U. S. A. A. F. photo

#### THE END OF THE AXIS IN AFRICA

When our bombers had finished softening up Ferryville Harbor in Tunisia, it marked the beginning of the end of all German and Italian opposition in North Africa. This photo shows our first attack on Ferryville.



U. S. A. A. F. photo

#### AMERICAN RAID ON NAPLES

In this attack on April 4, 1943, the main Axis military docks and defense installations were wrecked. This photo, taken from one of our bombers during the raid, proves the care exercised by our air forces to prevent bombing the helpless Italian people in non-military areas of the city.

shorter supply lines he could conquer the Eighth Army without drawing off too much of the German air force strength which was needed badly on the Russian front and in Western Europe. While he was consolidating his position and preparing for his next move, which was to be against Alexandria, the British struck.

They had been reinforced. Badly needed American tanks had come in; and so had an American air force. Our fighters had been flown across Africa to Egypt. Our bombers had come over the same route. Many bombers en route to reinforce our small group in India were set down in Egypt for this emergency. Throughout July and August, 1942, the Royal Air Force and our Ninth Army Air Force attacked the Axis armies at every point. They smashed enemy bases, supply and ammunition dumps, airfields and all the lines of communication. Axis docks and shipping in North Africa, Crete and Greece were knocked out time and again. The supply lines from Tripoli were kept in a state of wreckage. Above all, the Allies wrecked Rommel's great specialty, his fuel supply system so vital to his mechanized army and his air force. His special tanks for gasoline and oil were



hunted and destroyed, and so were his tankers. The Allied air forces cut Rommel's supplies 20 per cent, then 50 per cent. From July 1, 1942, when Rommel was stopped at El Alamein, until October 23, when the British Eighth Army started him on the long retreat westward, our American air forces alone dropped 3,374,000 pounds of bombs. They blew up Rommel's last tanker in Tobruk harbor one week before the British Eighth Army broke through his lines.

After that the R.A.F. and Americans kept over the fleeing Axis. They smashed all motor transport. They blasted Axis airfields and kept the enemy planes on the ground so they could be destroyed at



U. S. A. A. F. photo

#### OUR FIRST ATTACK ON ROME

The Germans lost hundreds of planes when our Air Forces bombers blasted the Ciampino airfield during our big raid on July 19, 1943.

will. Collapse of his air strength prevented Rommel from offering any successful opposition. Our aviation engineers repaired the airfields as they were captured; and other aviation services, including air transport and repair, kept Allied air forces supplied, so that they functioned effectively against the Axis all the way back to Tripoli which fell on January 23, 1943. Up to then, besides the magnificent work of the Royal Air Force, American bombers had dropped 3,495 tons of bombs, and American fighter planes had made 3,244 sorties. Control of the air had won a whole country, Libya, for the Allies.

The Allied landings in North Africa on November 8, 1942, could not have been accomplished without control of the air. The expedition was made up of three sections, more than 800 ships, some from England and the others from the United States. Our Navy took our share of the convoy to Africa. Naval Aviation protected it all the way, and patrolled the surging seas so effectively that no ship was lost to submarines despite the fact that our convoy spread over an area 25 miles wide and much longer. Our Naval Aviation covered the landings, kept enemy submarines at bay for four days, and bombed and strafed enemy airfields into submission, destroyed tank columns, scattered troop concentrations, silenced shore batteries, provided cover for our landing barges, drove off enemy warships, directed artillery fire from our warships against shore installations, intercepted and dispersed enemy bomber formations, performed courier services and photographed results of attacks. Naval Aviation accomplished all that from its carriers, one of which also transported Army fighter planes across the Atlantic so that they could take off and speed ahead to attack and land at enemy airfields.

Large sections of our American air forces in England were flown to North Africa with full fighting equipment and, with the Royal Air Force contingents, they and the recent arrivals from home, formed the second prong of the pincers which helped crush the remaining Axis power in Africa. It was not an easy campaign, however. The Axis had all the advantages. Rommel had come into Tunisia, and another German army had been sent into Northern Tunisia to help him. He had extremely short supply lines by land, sea and air from Italy, and Sicily was only a few miles offshore. While the Allied armies were pushing ahead to close the pincers, Allied air forces were being organized into tactical and strategic units of a gigantic aerial army capable of waging a clearly defined campaign in a theater of war which involved land, sea and air—all very close to the enemy's main sources of supply. This air force was capable of working in closest cooperation with the surface forces.

The great tasks of the Allied air forces in the North African theater were to curb the enemy's aviation, to bomb and strafe him on the field of battle, destroy his supply lines in the rear and keep him from a successful retreat; and most important, to meet every



crisis that developed during the campaign. The most important crisis of all was not long in arriving.

Rommel, toward the middle of February, 1943, had been pushed back by the British Eighth Army at the Mareth Line. He turned to strike at the American armored forces who were threatening his flank, and within a few days was well on his way through the Kasserine Pass. He had made excellent progress in about 10 days, during most of which bad weather had made our aerial reconnaissance extremely difficult. The Allies then threw in all available air power. They struck at Rommel's advance troops, knocked out his supply trains coming up in the rear and then, after seeing him turn back, kept on strafing his troops. This gave the Allied armies a chance to organize their final push of the campaign.

In his report to the Secretary of War on January 3, 1944, General Henry H. Arnold, commanding the Army Air Forces, described some of the phases of that last battle in Tunisia which formed the basis for future air operations in other campaigns. He said: "Many of our present ideas about the Tactical Air Force were evolved in the heat of these desert campaigns. There is no doubt but that experience and new conditions modify many of our notions, but the present concept of the Tactical Air Force can be regarded as tried and proved in North Africa, Italy and New Guinea. The Tactical Air Force works in partnership with all the other components of air power. In North Africa it worked with the Strategic Air Force which concentrated on long-range destruction of targets like munitions establishments and supply ports. It worked also with the Coastal Air Force whose functions consisted of cutting the enemy's sea-borne supply route and protecting our own. The Tactical Air Force is also intimately concerned with the battlefield itself.

"It is misleading to say merely that the Tactical Air Force provides support to the ground troops. The word 'support' always makes people think of air power as an ancillary weapon of the Army or the Navy in a land or sea operation—as long-range artillery directed by subordinate ground commanders. This narrow conception appears to be firmly imbedded in the public mind as well as in the thinking of the inexperienced soldier subjected to his first enemy strafing. Fortunately for us, it was a conception shared also by highly experienced Axis strategists. Air 'support' was found more than adequate by the Germans in their blitz through France where their domination of the skies was all but unchallenged. Both Germans and Italians found another state of affairs in North Africa. There they were first knocked out of the air, and then were left with the choice of being driven into the sea or surrendering. Our combined air forces and navies saw to it that no Dunkerque took place.

"The Royal Air Force and our Army Air Forces functioned as a unit in Africa. Air and ground commands of both countries were

fully as integrated. The ground commander and the air commander lived side by side in the same camp, ate together at the same mess, planned and operated on equal terms in the closest possible manner. They both knew that only the long reach of air power could achieve a lightning triumph in Tunisia. The Tunisian campaign became another lucid demonstration of the soundness of having an airman run the air war while a soldier runs the ground war, but always working together.

"The battle for the Mareth positions began with an air blitz on enemy airdromes. Prior to the attack of the British Eighth Army, our entire air force concentrated on those airdromes. After the strength of the German air force had been reduced materially, our northern and central air units operated exclusively against the Luftwaffe, relieving the Western Desert Air Force and the Eighth Army of any concern over German air opposition. This left the Western Desert Air Force free to employ hundreds of bombers and fighter bombers to search out enemy concentrations and to operate with great effectiveness immediately in front of the ground units of the Eighth Army. At the crisis of the battle in front of El Hamma, our tankbusters were thrown in; the enemy broke and retreated. In this operation, the 146th Panzer Grenadiers Division was caught moving on a road and put out of commission by air attack.

"After a short pause, the Eighth Army attacked at Wadi Akarit. Again the air units in the north and center were concentrated on the German air establishments, and once more our Western Desert Air Force was free to work at maximum intensity on the German forces deployed around Wadi Akarit. Again the enemy retreated, this time more quickly than was expected, to a semi-circle from Bizerte to Enfidaville. At this point, it was the turn of the Western Desert Air Force to draw away what was left of enemy air power while the Tactical Bomber Force lent its strength to the attack by the First Army and the 2nd U. S. Corps.

"The battle for the capture of German forces in Tunisia began not on April 22, 1943, when the ground forces pushed off, but four days before when we sent 90 night bombers against the German airdromes. We had guaranteed to reduce the Luftwaffe to relative impotence by the dawn of the 22nd, and we did. In two days we destroyed 112 German airplanes. The spectacular destruction of the 20 ME-323 six-engine transports on the 22nd was part of our plan to knock the Luftwaffe down and to keep it down during the period of the ground movement forward. Those ME-323's were carrying the equivalent of a German regiment into Tunisia.

"But spectacular actions of this sort were not as decisive as the steady weight of air attack that the Tactical Air Force was turning on the enemy troops in front of the First Army. From the 22nd on, we had free fighter squadrons sitting over the German airdromes,



daring the Nazis to take the air. When they finally did come up, they were knocked down by a small proportion of our fighters. The great balance of our force was then sweeping a path for the main ground effort.

"The weight of daily attack during this period was heavier than any air force had ever delivered in collaboration with an attacking army. On May 6, during the final drive from Medjez el Bab to Tunis, we flew 2,146 sorties, the great majority of which were bomber, fighter-bomber or strafing missions on a 6,000-yard front. We blasted a channel from Medjez el Bab to Tunis.

"The precision and effectiveness of our bombing became dramatically evident as our ground forces moved into Ferryville, Bizerte and Tunis. The entire town and port of Bizerte had been filled with German establishments, and our planes went into attack with the intention of blotting it off the map. General Kuter's automobile entered the town on May 9th, and he drove around for over an hour without coming across a single inhabitant. In that time, he could not find a single building, however small, that had been left unscathed."

Allied control of the air over North Africa shortened the campaign which cost the Axis everything they had on that continent. It was control of the air which helped our ground forces and which kept enemy aviation away from our armies. The reason that the Axis did not put more air power into the campaign was that they did not have it to spare.

To complete the conquest of that part of the Mediterranean, Allied air forces reduced all resistance in Pantelleria, which the Italians had fancied as their Gibraltar. Sicily with her 25 airfields in enemy hands received so much Allied bombing for more than a week preceding the invasion on July 10, 1943, that the enemy's supply lines were shattered and he was forced to move most of his air squadrons to the Italian mainland. Within three weeks after our invasion not an enemy plane was left in Sicily. That was due to Allied control of the air.

It was the continuous bombing of all enemy lines for several weeks that forced Italy to get out of the war on September 3, 1943. When the Germans attempted to hold on in Italy, they too were subjected to terrific punishment prior to the Allied landing at Salerno, just below Naples. General Arnold described these operations in his report: "With the date of our landing at Salerno set, our air force swept forward with its full power. Our first objective was to disrupt the enemy's flow of supplies and reinforcements, and to isolate German divisions by dislocating the entire rail and communications system. To this end, we raked Italy from the toe to the Brenner Pass, flying 4,419 sorties and dropping 6,230 tons of bombs between August 17 and September 6, 1943. The damage we inflicted on key railroad junctions, rolling stock and repair facilities is still crippling Nazi

resistance on the peninsula. In this first phase we also concentrated on destroying airdromes as well as aircraft in the air and on the ground. From September 9 to September 11, we set about isolating the battle area. In this phase we flew 1,006 sorties and dropped 1,679 tons of bombs, achieving virtually complete interruption of traffic on the main lines leading to the contested region.

"On September 12, our Strategic Air Force joined the operations. On the next day, nearly all our bombers flew two sorties apiece. By September 14, whole towns in the area had been obliterated, motor transport concentrations smashed, and severe casualties inflicted on enemy troops. In those four days we flew 2,407 sorties and dropped 3,122 tons of bombs.

"On the morning of September 13, the commanders of our airborne troops were notified that air reinforcements were required by the United States Fifth Army within 24 hours. At 2045 hours on the same day, pathfinder units of the airborne task force took off from their Sicilian base, reaching the drop zone prepared by the Fifth Army on the Salerno beachhead at 2314. Twenty-five minutes later the first elements of the paratroopers arrived. In one and a half hours 90 aircraft dropped 1,300 paratroopers and equipment in an area approximately 1,200 by 800 yards. By 0200 hours, September 14, these paratroopers were completely organized and marching into position on the front line. Many of the units had had less than two hours to give their planes a final servicing, arrange take-off plans and load men and equipment.

"On September 14, the operation was repeated, this time with 131 C-47's dropping 1,900 paratroopers in the same zone while 40 C-47's carried a battalion of infantry and a company of engineers to a zone five miles southeast of Avellino, behind the enemy lines. Just 24 hours after completing these three jobs without a fatality, the troop carriers were back at work, flying in essential supplies to the Fifth Army, and evacuating wounded. There was no resisting an effort of that magnitude. The Army Air Forces did much to save the day at Salerno. The breach it helped make in the European Fortress can never again be sealed.

"During one year's operations (from November 8, 1942, through November 7, 1943) in the Mediterranean theater, Allied aircraft of the Northwest African Air Forces dropped 92,233 tons of bombs on enemy installations and supply routes. Of this total 65,377 were dropped by the Army Air Forces. We hit targets in Austria, Jugoslavia, Greece, Albania and France as well as in North Africa and Italy. In this theater we destroyed in aerial combat and on the ground 5,511 enemy aircraft, probably destroyed 750 and damaged 1,903. Of the total destroyed, it is estimated that 4,100 were German, the rest Italian. Aircraft found abandoned in enemy territory, including Tunisia, Pantelleria, Sicily, Italy and Corsica, totaled 3,491; of these



1,986 were German and 1,505 Italian. An additional 231 aircraft were found at the Castel Benito airdrome, near Tripoli, but these are excluded from the above totals because they had previously been reported by the Middle East Command. During the same year, ending November 7, 1943, the Northwest African Air Forces sank a total of 185 merchant ships, totaling 173,400 tons; probably sank 110 ships, totaling 187,000 tons; and damaged another 243, totaling 373,700 tons. In the meantime, the Malta, Middle East and Ninth U. S. Air Forces accounted for at least another 2,500 enemy aircraft, and dropped at least 45,000 tons of bombs."

The North African campaign pointed the way to future developments, because the application of Allied air power up to the bitter battles against the German in Central Italy contained all the elements of complete victory obtained through the use of air forces capable of winning absolute air control and providing effective cooperation with surface forces. The North African victory closed one of the three major campaigns to be won by the Allies during the first 28 months of war. The two other completely successful campaigns were in the Pacific; one in the Aleutian Islands and the other in the Solomons.

The North Pacific campaign was started by the Japs during the first week of June, 1942. Our Naval Aviation found a huge Japanese fleet approaching Midway Island in five columns, about 80 ships in all. During the next few days Naval Aviation, with the help of some Army Air Forces squadrons, won the Battle of Midway in one of the decisive battles of the war. Japan's effort to hurl the best of her sea and air power across the Pacific and invade the North American continent had failed. Meanwhile, part of the Jap invasion fleet had turned north, and on June 3, the Nipponese bombed our Naval base at Dutch Harbor and the Army's Fort Mears nearby, and landed troops on our Aleutian islands of Agattu, Attu and Kiska.

Our Army and Navy air forces worked for months fighting the Japs in the Aleutian wilderness of snow and ice and almost perpetual fog. New Army air bases and the Navy's baby carriers cooperated in softening the intruders by way of the air, preparing the islands for actual capture by surface forces. The Japs abandoned Agattu. Combined land, sea and air operations early in 1943 resulted in a battle of extermination. Attu fell to our Army forces on May 20, 1943.

Seven weeks later, on July 19, our Army Air Forces raided Jap bases on Paramushiru, the first of a ceaseless campaign of aerial invasion against Japan's northern possessions. Our final assault on Kiska started on August 1, 1943, and for 12 days our Army and Navy air forces made many attacks every 24 hours, sometimes averaging one an hour. On August 13, our Navy ships opened fire on Kiska and drew some return fire. That afternoon our Army Air Forces bombers made nine attacks. Next day American and





U. S. Navy photo

## AIR SUPPORT FOR THE ATTU INVASION

Sturdy little escort carrier "A" (seen from a Navy plane off Attu Island) supplied aerial support alone on many occasions throughout the first ten days of the invasion of the Jap stronghold. Grumman Wildcat fighter planes took over the job when land-based planes on Amchitka were fog-bound. The tactic employed was flying over the fog until a break revealed a Jap position, striking, swooping out to sea and then attacking again until the gas ran low. With their .50-cal. machine guns, the Wildcats sank Jap barges which tried to close in on American landing forces.

Canadian troops occupied the island, and found that the Japs had sneaked away just as 14 months before they had sneaked in. Absolute control of the air had contributed its mighty part in freeing the Aleutians for future operations against Japan.

The war in the South and Southwest Pacific has been as bitter and relentless as that in Europe and Asia. Operating on the principle that he who controls the air controls everything, the Japs had extended their lines and built bases throughout the Southwest Pacific all the way from the Philippines to New Guinea and in the South Pacific as far as the Solomon Islands, where they were a menace to all our air and sea routes to Australia. The Japs also had set up strong bases in New Guinea at Lae, Salamaua and other points, and on New Britain they had fortified Rabaul, built several military air-



fields and then had placed a vast group of protecting outposts on neighboring islands. Our Army Air Forces were beginning to receive a few airplanes capable of operating out of our new base at Port Moresby on New Guinea from which many of the Jap strongholds could be hit. The Japs began to retaliate, however, hitting Moresby nearly every day.

In May, 1942, a huge Jap invasion fleet was spotted in the Coral Sea. A Navy task force caught part of it and sank several enemy warships. A few days later, air scouts found the main body of the Jap fleet, and for two days there was a battle in which for the first time carriers from both sides were involved, and actually the first sea battle in which the fight was entirely in the air. Our Naval Aviation made imperishable history in that battle. Army bombers also participated. We lost the carrier *Lexington* and two smaller ships. Japan lost 19 ships sunk or irreparably damaged.

The Battle of the Coral Sea offered the first definite proof that air power could stop a sea-borne force. It was a preliminary to our main Solomons campaign which started early in August, 1942, with carrier based aircraft operations against the Jap positions and landings by the U. S. Marine Corps.



U. S. A. A. F. photo

#### SALAMAUA PENINSULA

The Japs were clever enough to seize Salamaua Peninsula in New Guinea, and it took many months of campaigning for Allied land, sea and air forces to dislodge them. This is an Army Air Forces reconnaissance photo marked to guide our bombers to strategic positions.

Capture of the great airfield which the Japs had built on Guadalcanal was the beginning of our land-based air power in the Solomons, although our Navy ships and planes, Marine Corps troops and planes and Army troops and planes were to fight through the Solomons for many months until the last island of the group was freed of Japs early in 1944, and the campaign could be termed officially closed. Dominant air power helped to close the Solomons campaign, just as it materially helped the Allied advance from Port Moresby in the New Guinea campaign.

Our Army Air Forces flew 3,600 troops to Port Moresby to augment our forces. Then they stopped a Japanese army advance and turned the Nipponese back to the other side of the island. For the Japs this was the beginning of a long trail of bitter defeats which they still are traversing in New Guinea.

About 15,000 Allied troops later were flown to Moresby and thence to a new air strip on the other side, the first of many such operations, some with paratroops. Army Air Forces began bombing operations on a vast scale after they had the men and equipment. They attacked all Jap bases throughout the Southwest Pacific, and went to Rabaul, where the Japs could depend on being raided by air forces at first several times in a month, then several times a week, then daily for long periods of time, with our Army Air Forces going over one day, our Naval Aviation the next. Rabaul became one of the most consistently bombed places on earth; and by the end of February, 1944, it was of little use to the Japs for offensive purposes. That, too, was a factor in bringing the Solomon's campaign to a definite and satisfactory conclusion.

The effectiveness of air power when applied in the right place at the right time was demonstrated again by the Fifth Air Force when a bomber crew spotted a large Japanese convoy heading toward New Guinea on March 1, 1943. General Arnold described it in his report, as follows: "Thus began the Battle of the Bismarck Sea. During the three days that followed, the crews of 162 Allied planes repeatedly attacked this convoy and its protective cover of land-based fighters. Allied heavy bombers destroyed many Japanese fighters while on the ground at their Lae, Finschhafen and Gasmata bases. Other bombers, medium and light as well as heavy, made attack after attack on the convoy with highly co-ordinated precision and mast-head skip-bombing tactics. Techniques of this sort had been developed in the course of months of hard, driving rehearsals. By March 4, the convoy had been smashed. Both tactically and strategically, this was an outstanding operation. Besides the ships sunk, from 59 to 83 planes had been shot down and at least nine others damaged. Our air forces lost one B-17 and three P-38's in combat, and a B-25 and a Beau-fighter through other causes. Total Army Air Forces personnel losses came to 13, while the Japanese lost approximately 12,700 officers and



men. Entirely unassisted, the Fifth Air Force, besides disposing of large numbers of airmen and sailors, had wiped out an entire division of troops."

In August, 1943, Allied air forces downed 381 Jap planes in the Southwest Pacific theater in a series of attacks that created a serious problem for the Japs all along their chain of island bases back to Formosa. Japanese reserve planes and crews were hopped from one base to another in an attempt to prevent their Rising Sun from setting in the Southwest Pacific. That depleted reserves at other Jap island bases and probably helped to defeat them when our Navy task forces started westward. Naval Aviation helped to soften the Gilbert Islands for capture by our U. S. Marines. The Navy then attacked the Marshalls. This was followed by the raid on Truk, then the capture of Eniwetok Island, and effective raids on other islands, all in February, 1944. Our Army took part of the Admiralty Islands, about 200 miles north of Madang, New Guinea, in a brilliant attack starting on February 29. Our capture of the airport there early in March gave our air forces a base only 1,500 miles from the Philippines.

There are no less than five possible approaches against Japan, not counting the one from Siberia while Russia remains at peace with Nippon. There is one over the North Pacific from the Aleutians. There is the tortuous route from Australia up through the Netherlands Indies. A more direct route lies across the island chain from New Guinea to the Philippines. The straightest route extends across the Central Pacific, bypassing Truk and some of the other Jap outposts after our bombing renders them useless, and thence to the Philippines and on to the China coast. China provides the shortest route of all.

In his report, General Arnold described the situation in China, stating: "Our bombers have begun to make their presence felt in China, although in that theater we have not yet assumed the offensive. On the Asiatic mainland, time has, in one sense, been fighting on the side of the Celestial Empire. But time is a fickle ally. Potentially, China remains our most effective base for aerial operations against Japan."

In our war in the Far East, the routes we shall take to blast Nipponese aggression off the face of the earth will become apparent during the next few months. It was most significant when early in 1944, Vice Admiral John H. Towers, pioneer Navy aviator and former Chief of the Bureau of Aeronautics of the Navy, who helped to develop Naval Aviation to war strength, was appointed Deputy Commander in Chief of the Pacific Fleet and Pacific Ocean areas under Admiral Chester W. Nimitz. That was strong evidence that the Navy had plans to carry the air war straight into the heart of the Japanese Empire.

There was plenty of the earth's surface available for a many-pronged campaign against the Japanese by all the Allies attacking from land and sea. Japan still controlled an area equal to about four times that of the United States. Like Germany, Japan had her inner fortress; and also like Germany, that inner fortress was exceedingly vulnerable to air attack.

Germany offered a tragic example of the futility of trying to protect a country from strong air attack as the Allied bombing program gained in numerical strength and deadly effectiveness late in 1943. The British R.A.F. increased the number of planes used on each night attack against German centers, and destroyed most of the war industries in several of the largest cities, including Berlin. Our Army Air Forces were built up to astonishing strength in Britain, following the Allied announcement that invasion of Western Europe was being prepared.

In some respects our air forces there were as numerically strong as Britain's; and they were proving as destructive to the Germans. Our Army Air Forces and the R.A.F. were organized into two closely integrated Allied air forces, one strategic and the other tactical. During February and March, 1944, the strategic bombing of important German industrial centers grew in weight and results, with thousands of tons of explosives being dropped in a single attack.

Berlin, incidentally, was practically in ruins by the middle of March, as were many other German cities. The R.A.F. squadrons carried on their long-range attacks at night, doing pattern bombing over chosen areas, while our bombers continued their daylight precision attacks against choice targets. Our daylight raids on Berlin obliterated the industries and other important war facilities that the R.A.F. had missed. In March, 1944, the R.A.F. dropped its first six ton bombs on installations in German-held Europe—probably a token of things to come.

There were different viewpoints as to the actual results of the frightful bombing of Germany. Some held that if the Germans were to receive enough destruction by way of the air, they would capitulate without a surface invasion. Others were convinced that while German industry was being weakened and that constant destruction of her airplane factories might destroy the power of her air forces, still there was too much in Germany that would escape bombing, and that would let her fight on.

The continuous bombing of German installations in Western Europe on the invasion coast would make invasion easier and much less costly to the Allies, all agreed.

General Arnold in his report explained the Allied policy that dictated the air campaign against Germany and the strategy which it involved. He stated in part: "To destroy the will to fight is one of the secondary objectives of our air offensive against Germany. We



do not expect white crosses to appear tomorrow on the runways at Templehof. Our primary concern, simply stated, is to make the coming invasion of Germany as economical as possible by drastically reducing the war potential of the Third Reich and its satellites. Our strategic air plan is predicated on the fundamental fact that our bombers can fly deep into enemy territory, drop an effective load of bombs, and return to base without losses disproportionate to the damage accomplished. We have proved that we can do this. Our first step in the strategic bombing offensive is the destruction of the enemy's fighter strength. This is the logical operation to be carried out while we are developing our bases and building up our bomber fleet. It is a course dictated not only by logic but by the prime necessity of protecting our own aircraft.

"Fighter strength can be knocked out on the ground, in air combat or in the various stages before it rolls off the production line. We



U. S. Navy photo

#### THE NAVY ATTACKS RABAUL

This photo was taken during the raid on November 5, 1943, when U. S. Navy carrier-based Grumman Avengers and Hellcats and Douglas Dauntless dive bombers swooped down on the Japanese New Britain stronghold. They sank one heavy Jap cruiser and hit four others with torpedoes and bombs, hit another with bombs, torpedoed two destroyers and strafed a dozen more destroyers with heavy machine gun fire. Of 70 Zero fighters that rose to give battle our planes downed 26 certain, beside 22 probables.



U. S. A. A. F. photo

#### WE HIT THE JAP IN HAIPHONG

When our U. S. Army Fourteenth Air Force Liberators blasted the enemy rail center at Haiphong, French Indo China, on May 4, 1943. Our air forces continued to increase the number and effectiveness of their attacks on Japanese installations throughout enemy-held lands on the Asiatic mainland.

know that the nearer to the final assembly stage we attack enemy aircraft, the less time he will have to replenish his front line strength. Conversely, the farther away from the assembly stage his fighter aircraft industry is bombed, the more time he will have to take remedial steps. For quick results, we take out the assembly plants, but for some of the more lasting effects we concentrate on a system of targets deeper in the industry. The next objective of our bomber offensive is the smashing of industrial targets vital to the enemy's military strength on the ground. In brief, no bombing mission can be regarded as a single, self-contained operation. Each mission is thoroughly planned, with long-range objectives in view. Probabilities of error and minimum resultants are considered. Our strategy is based on a blueprint of scientifically calculated attrition.

"The equipment of our escort fighter aircraft with extra long-range disposable fuel tanks now enables them to give our bombers continuous cover to and from targets formerly out of tactical range. Another factor of great importance is the development of navigational aids so accurate that enemy targets can now be attacked by bombing through the overcast or at night.



"It is difficult to appraise the present struggle for air supremacy as representing anything short of a major turning point in the war. What American and Royal Air Force bombers can do to the whole German war machine, once the German fighter force is rendered impotent, needs no comment. The issue hangs now on which side first falters, weakens, and loses its punishing power."

The campaign to keep open our world-wide lines of supply may be termed another air victory, because air transport has played a vital role in one of the great dramas of this war, and too, Allied air forces have contributed extensively to the defeat of the German submarine campaign in the Atlantic. Supplies have gone through to all continents with very little delay and relatively few losses. During the last half of 1943, only one ship in a thousand was lost in the Atlantic convoys. That has enabled the United Nations to put our enemies on the defensive and keep them there pending the final crushing blows which will be more crushing and more quickly decisive if we succeed in establishing absolute control of the air on all fronts.



U. S. Navy photo

#### NAVY BOMBING OF WAKE ISLAND

Photo shows a Douglas SBD Dauntless during the attack on January 30, 1944.



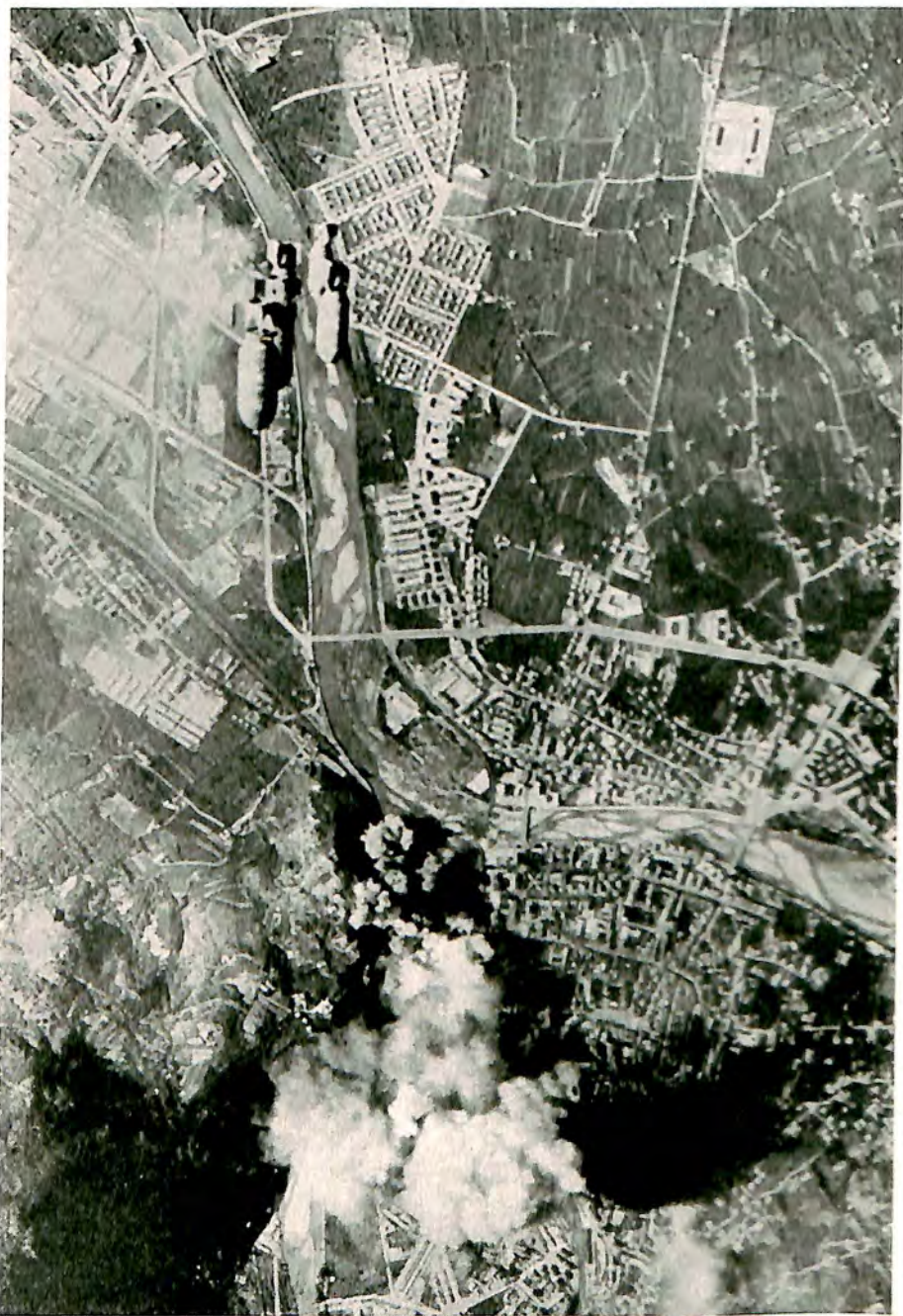

U. S. A. A. F. photo

#### BLASTING GERMAN SUPPLY LINES

When our Fifteenth Air Force smashed the railroad bridge at Balzano, Italy, less than 40 miles from the Brenner pass, it halted important enemy communications with his armies during the battle for Rome late in 1943.



## CHAPTER II

### THE AMERICAN RECORD

**A**S this is written early in April, 1944, absolute control of the air over all fronts, so essential to early victory, is being secured for the Allies by our predominantly superior technical progress in flying equipment, our vastly increased production of strategically important combat airplanes and the superb training and fighting qualities of our airmen.

The United States now has in service more than 75 different models of military aircraft ranging from trainers to the most devastating combat planes seen in action thus far during the war. We have under test other planes which promise to keep us ahead of our enemies in all kinds of air warfare over all fronts. We now have in service at least five different models of fighter planes with speeds over 400 miles an hour. England has three. Germany has two. Japan has none. Our Lockheed Lightning, Republic Thunderbolt, Grumman Hellcat, Vought Corsair, North American Mustang and the British Spitfire have outfought both German and Jap under all conditions. Our Bell Airacobra and Curtiss Warhawk have been effective in the particular kind of fighting for which they were designed. Russia, which has received nearly half of our Airacobra output, has used it to hold the Germans at bay in the air while smashing their tanks and routing them on the ground the length of the eastern front. Our Warhawks in the Asiatic theater have been wholly destructive to the Japs.

The Office of War Information late in 1943 used its official sources to compile a comparative record of American aircraft in combat. It reported: "The Lockheed Lightning has met and defeated the latest versions of Germany's two best fighters, the Focke-Wulf 190 and the Messerschmitt 109, as well as the Jap Mitsubishi 00 Zero and the so-called Superzeros, 00MK2, type 01 and the latest type 03. The Republic Thunderbolt has proved itself superior to the best German fighters, especially at high altitude. The Navy Vought Corsair and Grumman Hellcat are far superior to anything the Japs have to offer so far. Both are in the 400 miles an hour class and have high performance. The latest and best of the Jap fighters is the Mitsubishi 03, latest version of the Zero. It has some armor protection for the pilot and more firepower. But it is definitely inferior to the Corsair and the Hellcat in both safety and performance."

Within a few months after that OWI report, the new North American Mustang and the Lightning were escorting our bombers on long-range daylight attacks against Berlin and other German cities.



U. S. A. A. F. photo

## BOMBING OF NAURU ISLAND

U. S. Army Air Forces smashed Japanese installations here using Consolidated Vultee B-24 Liberator bombers.

No enemy bomber has approached in range, bomb-load, accuracy and defensive power the effectiveness of Allied long-range bombers such as our Boeing Fortresses, Consolidated Vultee Liberators and the British Lancaster. Each of those bombers has been developed, through successive models to meet changing requirements, for specific missions against the enemy. Our Fortresses and Liberators have carried on steadily increasing daylight precision bombing operations over great distances across Europe and the vast stretches of the Pacific, each plane capable of dropping at least three tons of explosives squarely on docks, factories or other installations. The British night operations with their Lancasters pouring tons of bombs over whole areas such as Berlin and other centers have wrought mass destruction on a scale never approached by the Germans at the peak of their wholesale and indiscriminate bombing of London. Neither German nor Jap has been up over Allied areas with twin-engine bombers in any degree comparable to our twin-engine North American Mitchell, Martin Marauder, Douglas Havoc, Lockheed Ventura and the British Mosquito. Not since the early days of the war in Europe, when German Stukas dive bombed and machine gunned the panic-stricken peoples of France and the Low Countries, has there been anything to equal the frightful punishment levied against ships, docks,



forts and massed troops by our Douglas Dauntless and Curtiss Hell-diver dive bombers and Grumman Avenger torpedo planes. Only on rare occasions have the Germans or Japs succeeded in bringing their bombers and torpedo planes within effective range of their targets.

The OWI reported: "In the heavy bomber class, our Boeing Fortress and Consolidated Vultee Liberator are superior to Germany's Focke-Wulf 200K Kurier and Heinkel 177. The Japanese do not have any land-based four-engine heavy bombers. In the light bomber class, our North American Mitchell and Martin Marauder continue to be the world's best medium bombers. Their closest competitors are Germany's Dornier 217E and Japan's Nakajima 97 and Mitsubishi 01. In the light bomber class, the Douglas Havoc is in a class by itself. The Germans have nothing to compare with it. The Jap Mitsubishi 99 is not as fast, rugged or heavily armed as the Havoc.

The OWI report contained similar comments about other American planes. Of Navy torpedo bombers, it said: "The Navy's Grumman Avenger is outstanding. However, the Japs are coming out with a new torpedo bomber. It is a twin-engine, carrier-based

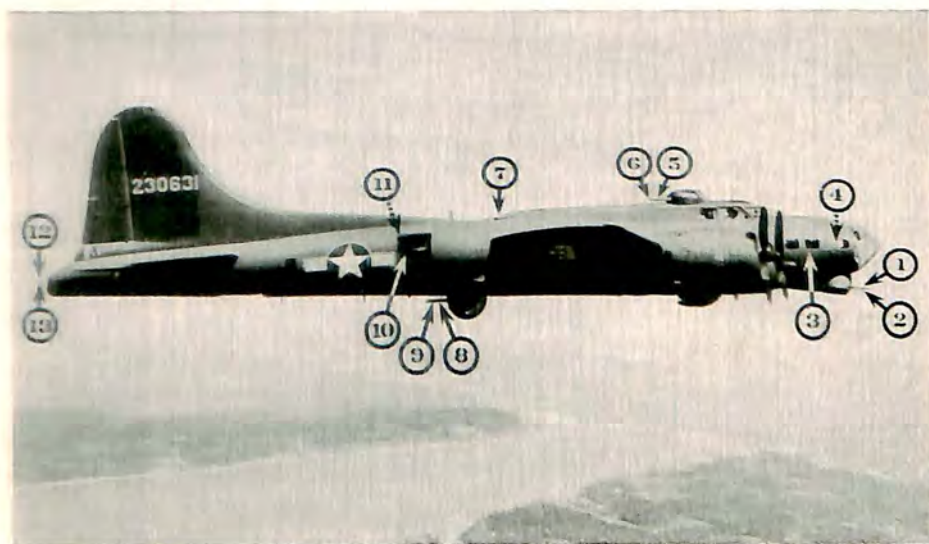

#### THE BOEING B-17G FLYING FORTRESS

Thirteen .50-cal. machine guns protected the bomber. Numbers 1 and 2 projected from the Fortress' new chin turret, a distinguishing feature of the Boeing B-17G. 3 and 4 were manually operated and supplemented the frontal fire of the chin turret. 5 and 6, mounted in the top turret, swept the skies above the Boeing bomber. 7, manually operated, was located in the radio compartment amidships. 8 and 9 were ball turret guns which covered under-side approaches to the Boeing. 10 and 11 were manually operated from the waist windows and commanded lateral approaches to the plane. Bringing up the rear were 12 and 13, comprising the deadly tail or "stinger" turret of the Fortress.



#### GRUMMAN HELLCATS

The new Navy carrier-based fighter planes which first saw action in September, 1943, in the Pacific campaigns against the Japs.

plane. The Japs have been using the Mitsubishi 01, a land-based plane, as a torpedo bomber. It is inferior to the Avenger."

The OWI also stated that "the Douglas Dauntless can get into a steeper dive, is more rugged, and has better armor than the Japanese dive bombers, Mitsubishi 01 and 07. The range and bomb capacity of the planes are about the same. The Navy's new Curtiss Helldiver has a longer range, more speed and greater bomb capacity than the Dauntless."

The need for continuous improvement was stressed in the OWI report from facts based on information secured from military sources. It said: "Nevertheless, even at this stage in the war, when clear cut air superiority over the enemy has been achieved, there is no assurance that the planes which have achieved it are superior to planes which the enemy may produce tomorrow. Changes in strategic and tactical problems, too, and changes of terrain over which fighting takes place, bring with them new demands for aircraft design and equipment. Even planes which have run up high box scores must be constantly improved and replaced. The make-up of our air fleet has never been static, and is not to become so."

Our continuous improvement in combat performance under the stimulus of war has been remarkable. The chief factors are aero-



dynamic refinements in the plane, increased engine power without corresponding increases in size or weight and the development of improved propellers.

In external aerodynamics, extensive improvements have been made in nacelle shapes and location, in cowling forms, in spinner shapes, in the elimination of scoops, vents and bulges, and in the control of accidental air leakage. In internal aerodynamics improved air ducts for engine cooling radiators, oil radiators and carburetor air radiators have served to reduce power losses.



U. S. A. A. F. photo

#### NORTH AMERICAN CANNON BOMBER

This photo shows the nose section of a North American B-25 Mitchell bomber with a 75 mm. cannon in the lower left section of the nose, with two .50 cal. machine guns just above.



#### WING TANKS ON THUNDERBOLT

The Republic P-47 Thunderbolt with wing tanks providing a large auxiliary supply of gasoline which greatly extended its range.

Refinement of wing shapes, fuselage shapes, windshield shapes, tail profiles and reduction or elimination of the extra drag caused by exposed rivet heads, sheet metal laps, inspection doors and landing gear cover plates have helped to improve efficiency in our American combat planes. The National Advisory Committee for Aeronautics low drag wing shape, now coming into general use on American airplanes, reduces wing drag as much as all previous research had accomplished since the Wright brothers invented the airplane in 1903. Because wing drag is the largest single item of drag in airplanes, its reduction will increase speed materially and reduce the power required. The North American P-51 Mustang, as the first production fighter plane equipped with this new NACA laminar flow wing, has won an enviable reputation on many fighting fronts for its ability to outperform enemy craft of similar or greater power. Late versions of the Bell Airacobra also embody this type wing.

The National Advisory Committee for Aeronautics also has contributed to important advances by its study of every profile of the airplane for elimination of adverse effects due to the compressibility phenomenon. This consists of shock waves in the air when the air flows over any portion of the airplane structure at a speed above the velocity of sound, generally 750 miles an hour. This condition



may occur on improperly shaped profiles at flight speeds considerably less than the speed of sound. It occasionally happens over some parts of the plane at flight speeds as low as 400 miles an hour.

Our aircraft engines develop greater power for less weight than formerly. Improved fuels, better cooling and improved working conditions in the cylinders, brought about by better valves, piston rings and lubricants are partly responsible. The weight per combat horsepower has been reduced about 40 per cent. Reliability and service life have been increased greatly. By the use of multiple rows of cylinders in radial engines, the horsepower per square foot of frontal area has been increased about 300 per cent. The tremendous improvement in altitude performance has been created by extensive research and engineering on supercharging systems which permit the engine to develop sea level power at high altitudes. The new Lockheed P-38 Lightning and Republic P-47 Thunderbolt models incorporate many refinements in powerplant and equipment which enable them to accompany and protect long-range high altitude heavy bombers on missions over enemy territory. These continuously improved versions of our fighters are effective at any altitude, but are especially designed to fly and fight at seven to eight miles above the earth. The range of airplanes of all classes, notably bombers, has been increased materially by the same factors that have increased airplane speed, and



N. A. C. A. photo

#### FOR HIGH SPEED TESTS

This large laminated wood propeller, driven by nearly 20,000 h.p., creates an air-stream faster than 400 miles an hour in the altitude wind tunnel at the National Advisory Committee for Aeronautics Cleveland laboratory. The National Advisory Committee for Aeronautics developed a special technique for fabricating large propellers for its numerous large wind tunnels.



U. S. Navy photo

#### THE CURTISS HELLDIVER

The Navy's new dive bomber had its first big battle during the carrier task force raid on Rabaul on November 11, 1943. Screaming down through a flock of about 80 Jap Zero fighters and heavy anti-aircraft fire, a squadron of 23 Helldivers blasted the harbor into an inferno of burning, sinking ships. A light cruiser and two destroyers were sunk and eight destroyers badly damaged.

also by improvements in structural efficiency, that is, by improvements in the design of structural members so as to make them stronger without proportionately increasing their weight; and also by decrease in the fuel consumption per horsepower hour.

To give our combat aircraft an extra burst of speed to evade or outmaneuver the enemy in a tight spot, many new models are equipped with so-called water injection system, which permits operation at increased power for limited periods of time.

Many of the new technical developments have been designed to meet military requirements for continuity of operation. In order to realize the maximum use of air power, military airplanes must be able to take off, fly, fight and land under extreme weather conditions, in sub-zero temperatures as well as 120 degrees above, through wind storms or Arctic blizzards, operating to and from unimproved wilderness airports with regularity.

One of the most notable developments has been the application of exhaust heat anti-icing systems to airplanes. The Liberator bomber was the first military airplane to use this system which had been proven experimentally by the National Advisory Committee for



Aeronautics. With this arrangement, the hot engine exhaust gases are carried out through the wing to prevent formation of ice on the leading edge. This permits the wing to retain its normal lift even under severe icing conditions which would normally make operations impossible or extremely hazardous.

Early flights at high altitudes revealed that equipment often refused to function properly, or at all, under the extreme low temperatures encountered. Now all parts, control systems, radio equipment and guns must meet low temperature performance requirements before being approved for use in military aircraft. The development of equipment satisfactory in these conditions has required many thousands of hours of research with new materials and designs.

The crew as well as the mechanical equipment must be considered when high altitude operations are undertaken. Originally each crew member was provided with individual oxygen masks and electrically heated flying suits connected to central systems. Recent progress in this country has been directed toward cabin or cockpit supercharging for both large and small airplanes. In these systems thermostatically controlled warm air is supplied for the comfort of the occupants, thus maintaining their efficiency at a high level. Cabin and cockpit supercharging now embodied in production models is believed to be an exclusive American development.

Arctic and winter operations always have involved take-off and



N. A. C. A. photo

#### FOR GREATER HIGH SPEED EFFICIENCY

This N. A. C. A. photograph, taken by the Schlieren method, shows compressibility shock waves which are encountered by aerodynamic shapes at velocities in the region of the speed of sound. Fundamental information of this type obtained by the National Advisory Committee for Aeronautics is valuable in devising means for minimizing losses in aerodynamic efficiency at high speeds.

landing hazards on icy airport runways. Under such conditions the brakes on airplanes equipped with conventional rubber tires are useless. Heavy fast-landing airplanes would roll indefinitely on icy surfaces were it not for special tires with internally molded or detachable cleats which dig into the ice and allow brakes to be applied effectively. These devices permit our military aircraft to complete their missions under positive control, and prevent costly ground accidents which would take them out of action.

There has been material improvement of propeller thrust in take-off, in climb, and in high speed, and also in the effectiveness of the propeller in assisting in cooling the engine. This has come through improvement in the blade profile as a result of high speed wind tunnel studies and also through improvement of the blade shape, including the use of cuffs near the propeller hub. The net propulsive efficiency of propellers has been increased about 10 per cent.

In addition to numerous technical refinements in conventional propellers, the last year witnessed wide application of four-blade types to military airplanes. This revival of an early arrangement was necessitated by increased power of engines in existing airplane models. Rather than to increase the propeller diameter to absorb the increased power—a change which would require landing gear redesign—the fourth blade has been added. Contrarotating propellers which provide a means for additional power increases are coming into use. This type reduces the effect of engine torque, and permits more effective control under all conditions. The contrarotating propeller which in its present form consists of two three-blade propellers mounted coaxially only a few inches apart has been proven experimentally and soon will appear on powerful new production fighter models.

The last year has witnessed many remarkable innovations in the field of aircraft armament. Outstanding was the installation of a 75-mm. cannon in medium bomber models. After successful results were realized from an experimental installation in the field, a modification of the North American B-25 Mitchell bomber, incorporating this installation, was placed in production as an aerial destroyer of light naval units as well as tanks and artillery positions. It is especially deadly when used on low level strafing and bombing missions against enemy airfields and industrial targets.

Further improvements in power operated gun turrets were made during the year with some units carrying four .50 cal. machine guns. Remote control turrets are now coming into use incorporating intricate and efficient compensating sights. This development permits cleaner airplane design with gun installations arranged to permit the most complete protection. New multi-engine bomber models with this type of armament should be almost invulnerable to air attack.

Material substitution is a conservation measure familiar to all industries in time of war. Modern aircraft incorporate innumerable



examples of such conservation. Many of these substitute materials have proven their superiority over those originally used. For example, the cord of aircraft tires originally was made of cotton. Now nylon is used and provides tires which are not only substantially lighter than the prewar model but are over 60 per cent stronger. This has permitted airplane weights to be increased substantially in order to carry heavier loads without redesigning the landing gear for larger wheels and tires. Plastics have found wide use in aircraft and undoubtedly will be retained as more suitable for the purpose than many of the original materials. Plastics are used in such items as propellers, wind-



#### BELL AIRACOBRAS IN FLIGHT

An Army Air Forces squadron starts out in pursuit of enemy raiders in the South Pacific.

shields, ammunition boxes, gun turrets, engine parts, antenna masts, jettison tanks, speed indicators, bomb racks, miscellaneous fittings, fairings, doors and wing and tail parts.

The uses to which new developments in radio have been put in military aviation will form an astounding chapter of the history of this war after official secrecy has been removed. Navigational instruments have contributed much to our efficient long-range operations. The flux-gate compass, with its remarkable accuracy regardless of a plane's position with respect to the magnetic pole, permits accurate navigation under all conditions. Scores of other new devices permit dependable communication between planes and between planes and ground stations or ships.

A spectacular development was revealed by the joint U. S. Army Air Forces and British R. A. F. announcement of the first practical application of jet propulsion. Although Axis powers have been working on many variations of jet and rocket propelled aircraft, it has remained for Anglo-American ingenuity to solve the numerous mechanical complexities which have prevented earlier realization of the inherent advantages of jet propulsion. The British designed power unit was perfected and produced in this country for installation in a specially developed Bell military airplane through the close cooperation of scientists, engineers and production experts. The successful experiments were revealed early in 1944 with the announcement that the craft was being placed in immediate production for the armed forces of the United Nations.

The jet-propelled Bell fighter, according to an Army Air Forces statement on February 25, 1944, had two General Electric jet propulsion type engines, and of course no propellers. It had a high speed and a high ceiling, and was heavily armed and armored. Freedom from vibration and simplification of the pilot's controls were important characteristics.

Of more immediate interest, because it promised to contribute quickly to our absolute control of the air, was the new Boeing B-29 long-range Superfortress, with four 2,200 horsepower Wright Cyclone engines and Hamilton-Standard four-blade propellers, the most powerful flying machine ever placed in production. The Superfortress was capable of longer range, carried much heavier bomb loads and possessed greater defensive armor and more armament than any bomber as yet in service. Squadrons of these Superfortresses were to be in the air against the enemy on several fronts before the end of 1944.

Development of our wartime transport service was one of the most important contributions to control of the air, because it provided speedy transportation of personnel, munitions and other supplies to distant bases on all fronts. Establishment of our military airways throughout the world also permitted the fast delivery of aircraft,



parts and other vital supplies to points where strategy and tactics demanded immediate concentration of air force strength. Our American transport aircraft were unequalled anywhere. They were to play even more important roles as the campaigns drove the enemy back on his home base, because here our need for emergency air transport would be most pressing.

The Martin Mars, the world's largest flying boat, spectacularly demonstrated two important characteristics of our military aircraft—range and useful load, ability to carry large loads over great distances. The Mars, shortly after its acceptance by the Navy, made a series of world record breaking flights for distance, speed and weight. On its first war mission, the Mars carried 13,000 pounds of mail over 4,000 miles non-stop to Brazil and brought back 23,000 pounds of critical war materials. On one lap of the return journey the boat carried 35,000 pounds of cargo, the largest load in history. On one flight the Mars took off at a gross weight of 148,500 pounds, the greatest load ever lifted by an airplane. Twenty additional Mars flying boats were ordered by the Navy to augment the Naval Air Transport Service fleet.

Developments in the helicopter, the most notable example being that of Igor Sikorsky, might have a definite influence on the trend of



THE LOCKHEED P-38 LIGHTNING

Close-up of the famous Army Air Forces twin-engine fighter which demonstrated great versatility as a multi-purpose combat plane on all Allied war fronts.



#### BATTLE-SCARRED BUT STILL FLYING

This Martin B-26 Marauder Army bomber was hit by a direct burst of flak in Tunisia. The pilot, Capt. Frank Bedford, brought the ship back to its base and landed it safely on its belly, receiving the Distinguished Flying Cross for his feat.

military events in many areas. The Army Air Forces had ordered Sikorsky helicopters placed in production with a view to using them for observation, artillery spotters and behind the lines liaison. The Navy was experimenting with them for patrol duty on ship convoys to detect and destroy enemy submarines before they could strike.

While more than a thousand new inventions and refinements of existing devices contributed to the superiority of our flying equipment and our methods of using it to best advantage against the enemy, there were as many technical improvements which served to increase our production of warplanes to a point where it probably exceeded that of all other nations combined.

About 86,000 airplanes were built in American factories during 1943, according to a statement by James P. Murray, president of the Aeronautical Chamber of Commerce of America. "Poundage of airframes," said Mr. Murray, "is the most accurate yardstick of aircraft production for the armed forces. Our 1943 poundage represented frames and spare parts for an estimated output of 85,946 planes, 80 per cent more than the number produced in 1942 and four and a half times the production of 1941. In 1941, poundage was 83,500,000 pounds for an output of 19,290 aircraft. In 1942, it was 276,000,000 for 47,873 planes. In 1943, the poundage was 667,000,000. The figures showed that the average weight of planes built in 1943 was nearly double that of 1941. That meant a greater proportion of heavy bombers and transports compared with smaller and lighter planes.

Late in 1943, Robert A. Lovett, Assistant Secretary of War for



Air, stated that over one half of the Army's production in 1944 would be aircraft and auxiliary equipment. That showed clearly the emphasis put on air power. General Henry H. Arnold, commanding the U. S. Army Air Forces, in his report to the Secretary of War on January 3, 1944, gave a most comprehensive description of the growth of aircraft production and all that it involved as a contribution to the war effort.

"During January, 1942," said General Arnold, "the number of aircraft produced in this country totaled 2,972. In January, 1943, the total had risen to 5,013. In September, 1943, the total reached 7,598. Even more interesting, however, is the September, 1943, total of 7,598 as compared with 117 for September, 1939, when the war started. During November, 1943, approximately 8,800 planes were produced. At the same time that these gains in numbers were made, greater gains were made in the size of the planes produced and in their quality as fighting weapons. Weight is a better gauge of production growth than numbers. Production of airplanes, measured on a weight basis, has increased more rapidly during the last half year than during 1942."

General Arnold then presented a table showing the expansion of the aircraft industry, listing only final assembly plants in the United



U. S. A. A. F. photo

#### CURTISS WARHAWK AS A BOMBER

The Curtiss P-40 Warhawk fighter plane was the "B"-40 in several theaters, where bombs were fastened to the ships. In Burma, thousand pound bombs were fastened to the P-40 and used against the Japs with devastating results.



### THE NEW CONSOLIDATED VULTEE LIBERATOR

Used by the Army Air Forces with spectacular success over many war fronts, the B-24 Liberator was an important long-range bomber. Photo shows the new, electrically operated nose gun turret. From 10 to 14 .50-cal. machine guns guarded this Liberator bomber from attack at any angle.

States and a few Canadian plants engaged in activities financed by us.

### U. S. Aircraft Assembly Plants in Operation Military Production Only

Year	Engines	Propellers	Airframes
1938	4	2	9
1939	7	4	17
1940	12	4	25
1941	16	9	38
1942	22	13	51
1943	22	19	67

"We make no pretense of infallibility," General Arnold continued. "Calculating the demands of tomorrow's warfare is an extremely hazardous enterprise, due to the countless factors to be taken into consideration. We admit mistakes and promptly redesign or scrap the planes or equipment in question. The steep increases in airplane production during 1943 have been stimulated by the Army, Navy and the War Production Board in cooperation with the airplane manufacturers and the labor unions. These Government agencies strive to increase the flow of resources to the airplane industry and to improve the efficiency of their use. During the last eight months the flow of materials, such as aluminum, to the airplane industry has been raised substantially. During the same period the airplane industry experienced a 37½ per cent rise in labor productivity.

"Demands of the British, Soviet, Chinese and other Allied air forces for American airplanes continue to increase. Efforts to meet these demands will not be relaxed; there is a steady increase in the combat planes being made available to them. Seven thousand planes have been sent to Russia under lend-lease. It can now be announced that up to October 1, 1943, a total of 26,900 planes have been exported to our allies by lend-lease or direct purchase. These aircraft are being flown over Europe from the United Kingdom, Africa, Italy, the Middle East and the Mediterranean area by British, French, Polish, Czech, Norwegian and other airmen. In the Far East aircraft produced in the United States are being flown in combat by Chinese, British, Australian and New Zealand airmen. On the front from the Baltic to the Black Sea, Russian pilots have operated our aircraft as well as their own against the common enemy.

"One hundred and forty-five thousand planes are scheduled by the War Production Board for completion in the next 15 months. They will be heavier and more elaborately equipped. The average airframe weight of airplanes being produced now is twice as great as it was a year ago. The weight of heavy bombers to be produced in the next 18 months is scheduled to exceed that of all types of planes produced in our first year and a half of war. There must be no lag in production. Not one of our Air Forces has the planes it should have. Every one could use double the number it now possesses. It is a difficult task to decide which Air Force must do without the planes it ought to have, knowing what our refusals mean. They mean that a hundred planes have to do what would be a tough job for two



#### THE FIREPOWER OF A FLYING FORTRESS

This photograph, taken in England, shows a load of 37,500 rounds of .50-cal. machine gun ammunition taken up on each flight by a squadron of Boeing Flying Fortresses. At the same time each Fortress carried two one-ton bombs like those shown in this picture.





U. S. A. A. F. photo

#### STRIKING AT GERMAN SUPPLIES

Our Eighth Bomber Command Fortresses dropping bombs on Munster, Germany, on November 11, 1943

hundred. The Salerno beachhead was one of the turning points of the war, and we had just enough aircraft to cover our landing forces. The biggest battles in the air and on land are yet to be fought. We will need every plane we can produce.

"The complexity of aircraft production can be realized from the knowledge that a heavy bomber has over 400,000 component parts and perhaps 60,000 different parts. The manufacture of one single radial type, aircooled engine involves more than 30,000 major and minor inspection operations. The finished surfaces of working parts on engines are checked to a millionth of an inch.

"All kinds of devices are created and tested to improve the performance of our planes and increase their effectiveness as fighting machines. Our bombing accuracy has been improved by the new automatic flight control equipment, by which the bombardier operates the plane on the bombing run. The bombing run is shortened so

that our pilots can go into evasive tactics sooner. With the increased accuracy, fewer planes are required for a specific mission.

"The Production Division of Materiel Command, in order to produce airframes, engines, propellers, gliders and Government furnished equipment other than engines and propellers for our Air Forces, does business with over 500 prime contractors and 8,000 first line subcontractors for airframes, engines and propeller contractors. It must make sure that these manufacturers receive the necessary raw and fabricated materials at the proper time; expand existing factories or construct new ones where required; provide additional machines and tools; distribute parts to manufacturers to secure a balanced production; give assistance in engineering features during the development stage to insure that the product will meet our requirements; and perform all these functions so that a steady flow of airplanes is channelled to the combat areas.

"The plant personnel of these 500 prime contractors is well over one and a half million persons. The subcontractors employ many more. About 40 per cent of the total aircraft employees are women. In no other industry has woman power been more effective. Women are giving excellent service in research laboratories, as engineering aides, and on the production line as first-rate welders, riveters, inspectors. Our engineers and production personnel not only are building airplanes with performance and destructive power equal to or better than those of any in the world; they also are breaking one record for production after another as the months go by."



#### A THUNDERBOLT IN THE NIGHT

Republic P-47 Thunderbolt, fast and deadly Army Air Forces fighter, fires its eight .50-cal. machine guns.





## CHAPTER III

### THE U. S. ARMY AIR FORCES

ON March 9, 1944, the War Department made the following official statement regarding the growth of the Army Air Forces, as follows: "The Army Air Forces today marks the second anniversary of its establishment as one of the three major components of the Army and of the naming of General Henry H. Arnold as its Commanding General. In these two years, the AAF, built upon the foundation of the old Army Air Corps, has more than quadrupled its personnel, while engaging the enemy and achieving air superiority in every theater of war. The AAF, under the guidance of General Arnold, multiplied its strength from a little more than 500,000 men in March, 1941, to more than 2,385,000 at present. At the same time it has established 11 combat air forces overseas in addition to four air forces and many training establishments in the United States. The anniversary is regarded as a significant milestone in the development of American air power.

"Today, the total AAF strength is greater than the entire American Expeditionary Force of 1918, plus the total peacetime strength of the Army and Navy, with some to spare. Through its 11 combat Air Forces, the AAF is bringing in combat theaters throughout the world American air power to bear against the enemy in ever-increasing concentrations. To implement its combat strength, the AAF is operating an air transport service greater than the world's combined air transport system of prewar days and has built up, in the AAF Training Command, one of the world's largest training organizations.

"Maintenance operations are carried on by the world-wide Air Service Command. Combat troops and their supplies in constantly increasing numbers are flown by the Troop Carrier Command. Weather and communications systems have been established around the globe. Hospitals are being moved by air and wounded evacuated from combat zones on all American battle fronts. Aviation engineers, airborne with all their equipment, are hacking combat airdromes out of jungle or rebuilding overnight bomb-shattered air fields captured from the enemy for use by our planes against him.

"American industry has been geared to a combat aircraft construction program greater than that of any other nation. Not only has it made possible the creation of American air power; it has helped supply the combat and training squadrons of our Allies.

"Though only two years old as the Army Air Forces, the AAF has demonstrated that American air power has come of age among

the air forces of the world and through its strength is beginning to impose the will for victory of the American people on their enemies wherever found."

The U. S. Army Eighth Air Force, based in the United Kingdom, had cooperated with the British R. A. F. in waging a ceaseless campaign of destruction against key centers in Germany and German installations elsewhere in North Europe. The Eighth Bomber Command had won high honors in the severest kind of test—that of daylight precision bombing against the most vicious defense that the Germans could offer with both fighter opposition and anti-aircraft fire from the ground. The R. A. F. carried out its principal attacks at night, with remarkable success and relatively light losses. Our Eighth Bomber Command had encountered great difficulty in the early stages of the campaign. It had made 25 daylight assaults on the Germans in 1942, but with the diversion of a large part of its force to North Africa late in the year, its efforts became relatively light. With limited equipment and barely 100 combat crews available, losses stood out sharply, and replacements were slow in arriving. Two attacks around New Year's Day, one costing us six heavy bombers and the other seven, registered a 10 per cent loss. This was too high. The R. A. F. meanwhile was spreading ruin throughout North Europe, and there was much talk about throwing in our forces with the R. A. F. night bombing program. It was a critical period for the American daylight precision program for which all our equipment and training had been developed especially.

The question became an important item for discussion during the conferences of the Allied Chiefs of Staff in Casablanca in January, 1943. One of the officers attending the conference was Lt. Gen. Ira C. Eaker, chief of the Eighth Bomber Command from the beginning, and also commander of the Eighth Air Force in Britain after its original commander, Lt. Gen. Carl Spaatz, had gone to Africa to lead our air forces in that campaign. Eaker answered all questions on the scope of his operations to date, and then presented seven reasons for continuing daylight attacks. (1) Day bombing permitted destruction of relatively small targets like individual plants and factories that could not be seen or hit at night. Some of these were of vital importance to Germany's war effort. (2) Day bombing, being much more accurate than night bombing, meant that a smaller force could destroy a given target. When sufficient equipment was available, simultaneous attacks could be made on several targets, splitting enemy defenses and reducing losses. (3) Day bombing, or the threat of it, together with night bombing by the R. A. F., harassed the enemy 24 hours a day, with the consequent loss of manhours in production. (4) Day bombing would reduce airfield, airspace and communications congestion in the United Kingdom. (5) American combat crews were not equipped or trained for the totally different technique of night bombing. (6)

Day bombing imposed a serious strain on the fighter strength of the German air forces. (7) Day bombing offered unique opportunities for cooperation with the R. A. F. The two types of bombing were complementary, and joint operations had already been planned which would demonstrate the value of such combined operations.

The kernel of proof was the inability of the German fighters or flak to prevent American daylight bombers from attacking their targets. Repeatedly during the battle of Britain, Hurricanes and Spitfires had intercepted the bombers of the Luftwaffe and had driven them away. But the Germans had not been able to drive us away. This fact, combined with the success of the R. A. F.'s night operations, resulted in a new directive to the British and American bomber forces in the United Kingdom. The Chiefs of Staff at the Casablanca conference ordered a joint British-U. S. bomber offensive to accomplish "the progressive destruction and dislocation of the German military, industrial and economic system, and the undermining of the morale of the German people to the point where their capacity for

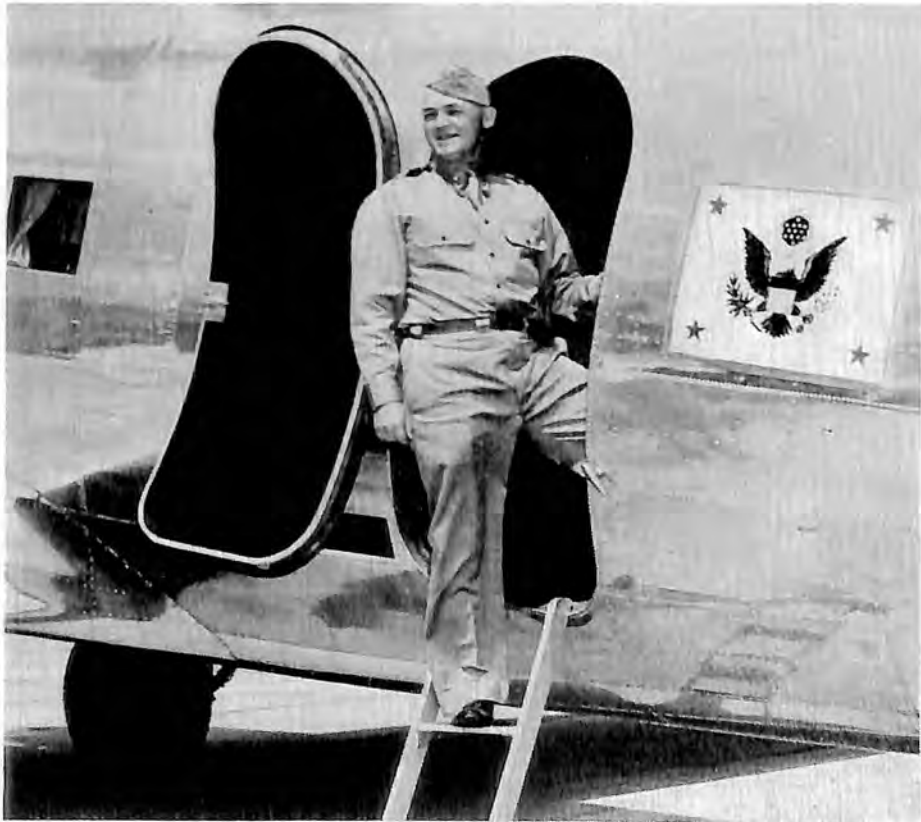

U. S. A. A. F. photo

GENERAL HENRY H. ARNOLD

The Commanding General of the U. S. Army Air Forces during an inspection trip.



armed resistance is fatally weakened." There was little doubt that this meant the indispensable preparation for invasion operations on the Continent, the so-called second front. It also settled two things—the Eighth would get its heavy bombers, and they would be used for daylight bombing. As a British Air Ministry spokesman put it, "Round-the-clock bombing is the aim. We are not doing as much daylight bombing as we would like, and we welcome every Fortress and Liberator that the United States can send to help us on that round-the-clock program."

As the British built up their strength of heavy Lancaster and Halifax bombers and an increasing number of aircrews were turned out in Britain and the British Commonwealth Air Training Program in Canada, the tempo of R. A. F. night assaults was stepped up. Six, seven, eight hundred heavy bombers over a target, then two or more targets: 1,500, 2,000, 2,500 tons of bombs, with ever increasing intensity, ranging from an average of 30 tons a minute in the spring of 1943, to 50-60 in the summer—such as on Hamburg; then the amazing figure of 90 tons a minute in the shattering attack on Brunswick on January 14, 1944—2,000 long tons in 23 minutes. Cologne, Essen, Dusseldorf, Duisburg, Dortmund, Hamburg, Wuppertal, Kassel—city by city Germany's key industrial centers were being knocked out of the war. The battle of the Ruhr, begun in March, was practically won by September, 1943. In November, the all-out effort to wreck Berlin, enemy headquarters and war industry center, was begun in earnest, recognized as the most important single target in Germany. By January 31, 1944, it was estimated that over 60 per cent of Berlin had been smashed. The German aircraft industry was completely reorganized and the main emphasis was switched to the production of fighter planes in an effort to ward off destruction.

Meanwhile, our Eighth Bomber Command, with a striking force whose strength at the beginning of 1943 was about 15 per cent that of the R. A. F. Bomber Command, had been hitting key objectives of the German war industry. During the early months of 1943, however, the drive against the U-boat had top priority, and the attacks on enemy submarine bases in the Bay of Biscay—Brest, Lorient, Saint-Nazaire, La Pallice and Bordeaux—began in October, 1942, were stepped up. At the same time a program of heavy attacks against the submarine shipyards in northwestern Germany was begun. The Eighth's first mission into Germany proper was against Wilhelmshaven on January 27, 1943. Emden was next on February 4, and on February 26, another attack was made on Wilhelmshaven. On March 4 the target was Hamm, where direct hits on the railway marshalling yards caused extensive damage to this important communications center. A similar attack on Rennes followed on March 8, with good results; and on March 18 came our mission to Vegesack. Seventy-three Fortresses and 24 Liberators, the largest force the Eighth had been able to put

over a single target to date, attacked the Bremen Vulcan shipbuilding yards on the Weser River, a few miles north of Bremen. Some 268 tons of high explosives were dropped on this fourth-ranking producer of U-boats, inflicting "extremely heavy damage." This included complete destruction of the powerhouse, two-thirds destruction of the shipbuilding shops, and heavy damage to a number of U-boats on the ways. It was the first notable use of the AFCE (aircraft flight control equipment) automatic pilot, whereby the bombardier takes over the control of the ship, increasing the accuracy and decreasing the length of the bombing run to under 20 seconds. When the damage assessment had been made from reconnaissance photographs, General Eaker made a statement to the press. "The men and the machines have proven themselves. The Vegesack operation was a successful conclusion to long months of experimentation in daytime, high-level precision bombing. After Vegesack comes a new chapter."

Wilhelmshaven was hit again on March 22, followed by attacks on the Rouen railyards and locomotive shops and the shipyards at Rotterdam. On April 4, some 250 tons of high explosive bombs were dropped smack on the Renault works in Paris, throwing a monthly total of 1,500 trucks and tanks out of production for months to come.



U. S. A. A. F. photo

#### ANOTHER GERMAN PLANT DESTROYED

This photo taken four hours after our Air Forces attack on the Messerschmitt plant at Regensburg, Germany, on August 17, 1943, shows the works practically destroyed.

This was a vital factor in the impending German disasters on the Russian front. These precision attacks had demonstrated to the German High Command that every target within range of the American heavy bombers was in mortal danger. Flak and fighter defenses were built up rapidly and concentrated around the most vulnerable areas. Bremen was one of these, and despite many R. A. F. night attacks the vital Focke-Wulf factory, one of the main units in the FW-190 fighter program, had escaped damage. On April 17, over 100 Fortresses ran the gauntlet of the fiercest fighter and flak defense yet encountered. Damage was so extensive that the plant was abandoned, and production shifted to Marienburg, East Prussia, about 900 miles from the Fortress nests in England. It was our most expensive mission to date, 16 Fortresses failing to return. Enemy defense appeared to be catching up with our offense. New tactics on our part seemed to be in order.

The month of May brought four new Fortress groups to the United Kingdom, and more ambitious plans could now be put into action. Early in May the successful attack on the Ford and General Motors plants at Antwerp included for the first time Republic Thunderbolt escorting fighters. These factories were operated by the Erla Machinwerke, one servicing ME-109 fighters, and the other Daimler-Benz engines. On May 14, the Eighth Bomber Command went out on its first multiple-target operation, designed to disperse enemy defenses. Eleven Martin Marauders slipped in at 50 feet altitude, evading German radio detection, and dropped delayed action bombs on the generating plant at Ijmuiden, Holland; it was their first mission, and a thorough success. Half an hour later, 100 Fortresses were crossing the North Sea heading for the big shipyards at Kiel. Enemy fighters came up and a battle royal resulted, but the Germania yards and the Deutsche Werke were bombed with "great destruction." Meanwhile 50 more Fortresses streaked across the channel and heavily bombed the important fighter field at Courtrai, damaging hangars, shops, dispersal areas and runways. Less than an hour later another force of Fortresses, with Thunderbolts escorting, flew high over Holland, turning abruptly at Brussels. Antwerp was the target. Bombing results were good. All that was a sample of what could be done with some 200 operational heavy bombers available.

In May, 10 of our Marauders, which went in at roof-top level, were lost, and the decision was made to use them thereafter at medium altitude with fighter support. During May, June and July our bomber strength was built up gradually. The targets included Emden, Flensburg, Wilhelmshaven, Bremen and Kiel once more. On June 22, the first American daylight penetration into the Ruhr district was made. The important synthetic rubber plant at Huls was heavily damaged. Shortly before this General Eaker had announced that the Eighth Air Force had doubled its strength since March and would double it again



by October, at which time its effort would compare in weight of attack with that of the R. A. F. Bomber Command.

In July, 1943, our Eighth Bomber Command ranged farther and struck harder than ever before, causing great destruction to both the enemy's industries and the Luftwaffe. On July 4, 10 and 14 multiple-target missions were carried out, averaging 275 Fortresses, against submarine bases, airfields and aircraft repair depots in France. Our attacks increased. On six days during the week of July 24, our heavy bombers reached into Norway and Germany for the largest and most sustained air offensive which our Army Air Forces had yet directed against German industry. On July 24, they made an attack on two targets in Norway, more than 2,000 miles round trip. One target was



U. S. A. A. F. photo

#### OUR ATTACK ON SCHWEINFURT

Results of the attack of the first wave of Army Air Forces Fortresses on the vital German ball-bearing plants on October 14, 1943.

the big new magnesium and aluminum factory at Heroya, completed three weeks previously after two years of construction. It was completely destroyed in four minutes. The other target was the important U-boat base at Trondheim. It was heavily damaged. On July 25, clicking with the devastating R. A. F. attacks on Hamburg, one formation smashed up the huge Blohm and Voss shipyards, which accounted for nearly one-fifth of Germany's shipbuilding production. Other formations struck heavy blows at the Kiel shipyards and Luftwaffe training school and airfield at Wustrow. The next day the target was the great Continental Gummiwerke at Hannover, largest tire factory in Germany. Hundreds of tons of bombs square in the target area produced a tremendous explosion, and the tire shortage in Germany, especially for supply trucks for the Russian and Italian fronts, became more acute.

After a rest on July 27, our bomber crews were out in force again on July 28, 29 and 30. Factories producing the Focke-Wulf 190 single-engine fighter, an important element in the bitter air defense of the Germans, were the principal targets; Kiel also was hit again. Our Thunderbolt fighters with auxiliary gas tanks made round trips of about 600 miles to meet the returning Fortress formations deep inside Germany, and escort them to safety. In the three days they downed 34 enemy aircraft against eight losses. The advantages of fighter escort were great. (1) With escort all the way to short-range targets, bombing accuracy was improved and losses held down to a minimum. (2) Partial escort on long-range objectives saved the bomber's ammunition and the fighting energy of the gunners for that part of the trip which they had to fly unescorted. (3) By meeting the bombers returning to base, crippled planes could be protected. (4) Aircrew morale was given a terrific boost. A skyful of Spitfires or Thunderbolts, and toward the end of the year of Lightnings or Mustangs, was always a welcome sight for our bomber crews.

To meet the all-out Allied air offensive, all kinds of defensive tactics were employed by the enemy, including amazing concentrations of flak, air-to-air bombing, captured and repaired Fortresses flying along with American squadrons to observe tactics and techniques, rocket projectiles and heavy cannon shells of 30-mm., 37-mm. and even 40-mm. But our Fortresses and Liberators got through to their targets, and without prohibitive losses.

The program to knock out German fighter aircraft factories was of the highest importance, but the first half of August saw heavy attacks on other vital targets such as the synthetic oil plants at Gelsenkirchen and Wesseling, and a precision instrument factory at Bonn. August 17 brought the greatest daylight air battle to date in the twin mission against the roller bearing works at Schweinfurt and the Messerschmitt 109 plant at Regensburg, turning out some 200 fighters per month. Both factories were heavily damaged, and over 300 Ger-

man planes were claimed as destroyed. Our losses were 59 Fortresses, with many of the crews bailing out to safety, though to almost certain capture. The Regensburg formations flew on to Africa. A few days later they bombed the Focke-Wulf factory at Bordeaux on the return lap of the first American shuttle-bombing operation. During the last half of August important fighter bases and repair depots in France were pounded steadily by Fortresses and Marauders, with Thunderbolts and Spitfires escorting.

Bad weather curtailed long-range operations into Germany during September, the raid against Stuttgart on the 6th being the only one of that type during the month. Even then heavy clouds obscured the primary target. Between September 2 and 23, eight heavy short-range missions were carried out, and smashing blows were inflicted on air bases, aircraft storage depots, aircraft assembly plants and engine factories in France. Fighter opposition was consistently weak. The Germans were saving their planes to defend vital industrial areas at home. On September 27, over 300 Fortresses, escorted by Thunderbolts for the 650-mile round trip to Emden, made their first "bad weather" attack, with pathfinder planes dropping British marker



U. S. A. A. F. photo

#### WRECKING A GERMAN PLANE FACTORY

When Army Air Forces Fortresses bombed the Messerschmitt plant at Weiner-Neustadt, Austria, October 24, 1943, they demolished the assembly plants and repair shops.



bombs to locate the target. Photos indicated good concentration on the city and in the port area. The weight of attack of the Eighth (Strategic) Air Force had been steadily rising during the summer, with the number of sorties and total tonnage of bombs for September being almost double those of June. Adding the effective work of the Marauders, now operating under our newly formed Ninth Tactical Air Force, the figures would be more than tripled, and at last approaching the impressive totals of the Royal Air Force.

October saw the main body of attacks switch to important industrial targets in Germany. Seven important missions were flown between October 2 and 24, bad weather preventing anything but cross channel sweeps during the last week of the month. On October 9, a sensational four-pronged attack was made on the Arado aircraft factory at Anklam, the Focke-Wulf assembly plant at Marienburg, shipping and harbor installations at Gdynia and U-boat construction yards at Danzig, the latter involving an 1,800-mile round trip. Bombing results were good, especially at Marienburg, described by General Arnold as the finest precision bombing operation to date.

On October 14, a large force of heavy bombers attacked for the second time the roller and ball bearing works at Schweinfurt, 65 miles east of Frankfurt. Over 550 tons of bombs were dropped on this fiercely defended target, and all five of the ball bearing factories in the town either were destroyed or damaged severely. Our losses were heavy—60 bombers—but General Arnold pointed out that the mission “amputates a huge part of the Nazis’ ability to keep moving machinery in operation.” The effect on front line fighting, of course, was far from immediate, but coupled with attacks on other ball bearing plants at Turin and in the Paris area, the ultimate effect promised disaster.

November was to see the heaviest weight of American air attacks yet delivered, with 10 Fortress and Liberator missions against 12 targets, totaling over 3,600 sorties and over 6,000 tons of bombs. On November 3, a submarine building yard was destroyed at Wilhelmshaven. Synthetic oil plants at Gelsenkirchen and railroad yards at Munster were blasted on the 5th. Railroad yards at Duren and Wesel were hit on the 7th. Munster was hit again on the 11th. The port of Bremen was hit on the 13th. Molybdenum mines, needed for steel, in Knaben and the world’s largest electrolysis plant in Rjukan (both in Norway) were battered on the 16th. The aircraft repair depots and an airfield at Oslo, were hit on the 18th. Our heaviest attack to date (500 bombers, with fighter escort all the way) was made on Bremen on the 26th, and an attack of moderate size on the 29th. On the 30th, machine tool and aircraft parts factories in Solingen were attacked with good results. All through November airfields and repair and storage depots in France were heavily pounded by Tactical Air Force Marauders, and Thunderbolts and Lightnings used as fighter-bombers, with a very low record of losses.

On December 1, 1943, a much heavier attack was made on Solingen. On the 11th, nearly 600 heavy bombers severely damaged shipyards and shipping facilities at Emden, which had assumed a new importance with the wrecking of much of the great port of Hamburg. On December 13, we undertook a huge triple-target mission against Kiel, Bremen and Hamburg, all three receiving punishment. Another exceptionally heavy attack was made on Bremen on the 16th, followed by one nearly as heavy on the 20th. On December 24, more than 1,300 American planes, nearly half of them heavy bombers, pounded the Calais area, without loss. On the 30th, our bombers made a very heavy attack on Ludwigshaven, dropping 1,400 tons. A mission against two important air bases near Bordeaux on the 31st was highly successful. Our air forces operating from England had dropped 55,000 tons of bombs on carefully selected targets in daylight during 1943, over half the tonnage being dropped during the last four months. Early in 1944, it was revealed officially that during November and December, typical bad weather months, many of the big attacks had been carried out successfully through an overcast by the use of newly developed "pathfinder" techniques.

On January 1, 1944, Lt. Gen. Carl A. Spaatz arrived in Britain to command the United States Strategic Air Forces in Europe (USSAFE). This included the Eighth Air Force, under Major Gen. James H. Doolittle, operating from nearly 100 bases in the United Kingdom, with more than 2,000 aircraft, including Fortress and Liberator heavy bombers, and Thunderbolt, Lightning and Mustang fighters for long-range escort in relays. Also included was the Fifteenth Air Force, commanded by Maj. Gen. Nathan F. Twining, based in Italy. The Fifteenth was administratively part of Lt. Gen. Ira C. Eaker's Mediterranean Allied Air Forces, Eaker having been transferred from England. The strategic bombing program from west and south was placed under the direction of the Combined Chiefs of Staff, of which Sir Charles Portal, top specialist in the bombing of Germany, was the Executive for Air. General Spaatz' deputy for operations was Major Gen. Fred Anderson, who had been bomber commander of the Eighth; his deputy for administration was Major Gen. Hugh Knerr, pioneer exponent of long-range precision daylight bombing. Gen. Knerr was also commander of the Air Service Command of the Strategic Air Forces. Major Gen. Edward P. Curtis was chief of staff.

During January, 1944, the Eighth flew over 6,000 sorties and dropped about 12,000 tons of bombs, including six heavy missions—two against Kiel, and one against Ludwigshaven, Oschersleben-Halberstadt-Brunswick, Frankfurt and Brunswick-Hannover—and an almost constant pounding by heavy, medium and fighter-bombers of the Pas-de-Calais invasion coast. During the first 15 days of February, our forces dropped over 12,000 tons of bombs on North Europe,



U. S. A. A. F. photo

#### BOMBING THE GERMANS IN YUGOSLAVIA

Our Twelfth Air Force Mitchell bombers over Sibenik, Yugoslavia, where they demolished German installations late in 1943.

the most concentrated daylight bombing in history. Fighter opposition was spotty, sometimes heavy and again light. The heavy blows inflicted on aircraft factories at Bremen, Regensburg, Marienburg, Oschersleben, Brunswick and several others, had curtailed production of single and twin-engine fighters. That was the indispensable first step toward victory. An authoritative summary of air accomplishments against the Western Axis in 1943 was given by Lt. Gen. McNarney, Deputy Chief of Staff, U. S. Army, when he estimated that the Allied bomber offensive, planned at Casablanca, had: (1) Weakened the position of the German Air Force and compelled redistribution of strength to the serious detriment of German operations on the Russian and Mediterranean fronts. (2) Laid the enemy oil industry open to critical reduction of supply through further attack. (3) Reduced deliveries of military equipment by successful attack on critical industries, such as aircraft and engine factories, as well as heavy industry. (4) Cut 1943 U-boat output and reduced the production capacity of major submarine bases. (5) Reduced the margin of safety in the German rubber situation. (6) Evicted 1,800,000 persons, diverted substantial resources to defense and repairs, destroyed public confi-



dence in German political and military invincibility and generally lowered morale.

Those notable achievements lacked the visible glamour of such successes as the capture of territory and defeat of armies, but they nevertheless proved to be a mighty contribution to the final result. The greatly increased Allied air effort in 1944 promised to be decisive.

Our Army Air Forces teamed with the R. A. F. in helping to drive the Axis out of North Africa. Our Ninth Air Force, then known as the U. S. Air Forces in the Middle East, commanded by Major Gen. Lewis H. Brereton, with headquarters in Cairo, had been cooperating with the R. A. F. Middle East (Air Chief Marshal Tedder) and General Montgomery's British Eighth Army since July, 1942. American units consisted of a heavy bombardment group flying Liberators, beginning operations in June, 1942, a medium bomb group of Mitchells, and a fighter group of Kittyhawks, both in action since August, 1942. The Allied air forces practically blasted the Luftwaffe out of the air before the break-through at El Alamein, and then clinched the victory with an aerial chase of the Afrika Korps, neutralizing Axis airfields in advance until air opposition collapsed. El Alamein to El Agheila was the second phase, ending December 14, 1942; and El Agheila to Tripoli was the third, ending on January 23, 1943, when Gen. Montgomery announced the fall of that prize seaport of Italy's colonial domain.

After the Allied armies landed in North Africa on November 8, 1942, the U. S. Twelfth Air Force, which had been training for some time in England, was transferred to Africa under the command of Major Gen. James H. Doolittle. Headquarters in Algiers were set up later, on December 14, 1942. Lt. Gen. Carl A. Spaatz was transferred to North Africa, ultimately to head up all American air forces in that theater. Handicapped by lack of forward airfields and by miserable weather, the first three months of fighting succeeding the Allied landing proved indecisive.

Following the Casablanca conference, the occupation of Tripoli, and the bringing up of powerful units of the R. A. F. Middle East and U. S. Ninth Air Force, now designated Western Desert Air Forces, a complete reorganization of the entire Allied air effort in the Mediterranean was effected as of February 18, 1943. Air Chief Marshal Sir Arthur Tedder became chief of the Mediterranean Air Command, including the Northwest African Air Forces, Malta Air Force and Eastern Air Command at Cairo. This sweeping reorganization contributed to the rapid success of the entire campaign by organizing the air command on the basis of the air tasks to be accomplished, and allotting to each air force or command the equipment required to carry out its particular task. These tasks were (1) air defense, (2) strategic air attack, (3) battle air attack, (4) air intelligence, (5) airfield construction, (6) air supply and maintenance, (7) troop carrier

operations, and (8) operational training activities in the theater.

The Northwest African Air Forces were commanded by Lt. Gen. Spaatz. Air defense was the task of the Coastal Command, under Air Vice Marshal Lloyd; Major Gen. Doolittle commanded the Strategic Air Force, and Air Marshal Coningham had the Tactical Air Force; Brig. Gen. D. A. Davidson was air engineer for the NAAF; the Northwest African Air Service Command was under Major Gen. D. H. Dunton; Col. Ray Dunn headed the Troop Carrier Command. Operational training and replacement of air units were carried out by Brig. Gen. James K. Cannon's Northwest Africa Training Command. With this remarkably effective organization, and the skill and daring of the men who directed and applied it, air power played a decisive part in the Allied victory in Tunisia. In addition, the valuable lessons in cooperation between air and ground forces by Tedder, Coningham, Montgomery and Brereton in the desert fighting were turned to rich account in the Tunisian campaign, and as Brig. General Kuter (Coningham's deputy) put it, provides a "pattern of victory, by which air power, in collaboration with field armies, will defeat the enemy." It was significant that this whole team, Eisenhower, Tedder, Coningham, Brereton and Montgomery later were given highly responsible assignments in the invasion of western Europe. Spaatz and Doolittle were appointed to continue their strategic bombing operations against German war industry.

By mid-January 1943, the Twelfth Air Force began to gain air superiority, shooting down enemy planes at better than two to one and inflicting heavy damage on ports, shipping, airfields and installations, trucks and supply dumps. Heavy bombers included Fortresses and Liberators; mediums, Mitchells and Marauders; fighter-bombers, Warhawks, Airacobras and Lightnings, the latter also being used widely as escort fighters. Minimum altitude bombing also had begun to achieve definite success in this theater. By February 10, when Montgomery's army rolled into Tunisia, the Allies had lost 255 planes while shooting down 625. Moreover the enemy's supply lines were destroyed by Allied air and naval blockade. The greatest crisis of the entire campaign was when Rommel, on February 18 to 20, smashed through the Kasserine Pass. Gen. Spaatz threw in every available airplane of the Tactical and Strategic Air Forces; and attacked roads, bridges, enemy positions, tanks, trucks and troop columns, meanwhile keeping the skies clear of enemy fighters and dive bombers. Strategic bombing of the Axis supply lines from Italy, Sicily and the African ports all the way to Rommel's army completed the program. The tide was turned and it marked the beginning of the end for the Axis in North Africa.

From this point on until the final collapse of the Axis in May, 1943, Allied air and ground victories were practically uninterrupted. Strategic bombing from British bases also played a part, as war supplies

and equipment were smashed in the factories, delayed at blasted railway junctions, destroyed on the docks or sunk in the Mediterranean. In these operations the Ninth Bomber Command contributed a heavy share from forward bases in Benghazi and Tripoli. Units of the Western Desert Air Forces, in addition to active cooperation with the Eighth Army from Tripoli to the Mareth Line, in the breakthrough and up the coast, played their important part in the destruction of a vast number of Axis air transports during the month of April.

Most of these transports were JU-52's, with a few ME-323's, a six-engine version of the huge Merseberg glider. On April 10, 1943, for example, the Strategic Air Force sighted a formation of JU-52's escorted by ME-109's flying over the Sicilian narrows. Our Lightnings shot down 13 of them and our Mitchells, not to be out-done by the fighters, destroyed 12. Earlier in the day Lightnings had shot down 28 other planes, including 20 JU-52's carrying gasoline and supplies which exploded as they hit the water. On April 18, pilots of 48 Warhawks of the 57th Fighter Group of the Western Desert Air



#### FIGHTER ESCORT OVER GERMANY

Republic P-47 Thunderbolts escorting Flying Fortress formations on a bombing raid over Germany.



Force, escorted by other American pilots in Spitfires, spotted over 100 enemy planes heading out of Tunis over the sea, trying to evacuate high officers and technical men. There were about 70 JU-52's escorted by 35 fighters. In a violent 20-minute engagement, American pilots shot down 58 transports and 16 to 18 fighters, and damaged 30 other planes. We lost nine pilots and planes. The episode illustrated the final stages of Air Chief Marshal Tedder's air plan in the battle area. (1) Instead of holding down air units with particular ground forces for "air support," thus dissipating the total air strength in small dribbles, attack the enemy air force in the air. (2) Then attack his airfields, further neutralizing his air power. (3) Isolate the battle area by strategic bombing of enemy supply lines all the way back to the sources, and by preventing reinforcements by land, sea or air. (4) Attack ground objectives in low-flying light bomber and fighter-bomber sweeps, including gun positions, supply and ammunition dumps, trucks and troops. (5) Prevent the escape of important personnel by air through constant air patrol of the isolated area. This formula was successful largely because air and ground commanders had equal authority while working together under a commander-in-chief of the entire theater in the closest possible daily, almost hourly cooperation. That was the great lesson of the North African campaign. It guided Allied strategy in other theaters.

As the ground forces smashed through on their magnificent drives for Tunis and Bizerte, the Tactical Air Force whipped their efforts to a frenzied climax by flying 1,200 sorties on May 5, more than 2,100 on the 6th, and about 2,750 on May 7, as the British First Army and the American Second Corps took those key cities. Only mopping up operations remained. However, there was more work for our air forces. Without delay, 400 American bombers on May 8, 1943, smashed the entire industrial center of Palermo, Sicily. The straits of Sicily had to be cleared, the island invaded and Italy knocked out of the war so that the important strategic objective of the whole campaign could be realized—Italian bases for heavy bombers to smash vital aircraft and engine factories and other war industries in the southern and eastern parts of Germany, and in Austria, Czechoslovakia and Poland. The first task was to knock out Pantelleria, the Italian "Malta." As an advance operation, some 40 raids were carried out during April and May, and then during the first 10 days of June the tempo was stepped up, some 3,500 tons of bombs being dropped, 1,400 tons on June 10, the day before the island surrendered—a unique victory primarily due to Allied air power. Day attacks were carried out by Fortresses, Mitchells, Marauders, R. A. F. Baltimores and Bostons, and Mustang, Lightning and Warhawk fighter-bombers. Night attacks by R. A. F. Wellingtons completed the pattern. During the final four days enemy fighter opposition had increased, but it was ineffective against the overwhelming Allied assaults. The Axis lost 74 planes.

Allied losses were very light. Once again, our air superiority had paid rich dividends.

Sicily was next. Throughout the rest of June and the first 10 days of July, bombers of the Strategic Air Force, Tactical Bomber Force, Ninth Air Force, and bombers and fighters based on Malta smashed at airfields, supply terminals, docks, marshalling yards in Sicily, southern Italy and Sardinia. As in the case of Pantelleria, the tempo was stepped up sharply before the invasion. From July 6 to 10, more than 3,000 tons of bombs were dropped on enemy airfields so as to knock out opposing air strength for the invasion on the 10th.

The Allied air forces thus played a vital part in the entire operation, by preparing the way for the landings, providing a fighter cover while they were in progress, and flying in thousands of airborne troops in Douglas Skytrain transports and Waco-designed CG-4 gliders. Within three days, 118 Axis planes were destroyed against a loss of 50 Allied planes. Photo reconnaissance revealed about 300 more enemy fighters on the ground in Sicily. Seven of the 25 airfields in enemy possession were rendered useless. About a dozen were captured by the Allies. Within the next day or two nearly 200 Axis fighter planes were driven from Sicily back to bases on the Italian mainland, and they were subjected to very heavy attacks from Allied bombers. The purpose of our spectacular raids on Naples on July 17, on Rome on July 19, and Foggia on July 22, with four attacks on



U. S. A. A. F. photo

#### THEY INVADED SICILY

One of our plane loads of paratroopers was photographed by flashlight just before they jumped out back of the Axis lines.



U. S. A. A. F. photo

#### BLASTING AXIS SUPPLIES IN ROME

The San Lorenzo railroad yards, one of the main transportation junctions of the Eternal City, were wrecked—a smashing blow at Axis morale.

Salerno, was to paralyze Axis transportation, to keep help from reaching Sicily, and to cut off in southern Italy those who might escape after Sicily had fallen.

The highly important daylight mission against Rome was a test as to what our bombers could miss almost as much as a test of what they could hit. More than 500 Fortresses, Liberators, Mitchells and Raiders—the mediums escorted by Lightning fighters—on July 19 dropped about 1,100 tons of bombs on the San Lorenzo and Littorio marshalling yards and the airfields at Ciampino. The damage was so great that the yards were knocked out completely for some days. They were just beginning to show some activity when, on the morning of August 13, about 100 Fortresses and over 150 Mitchells and Raiders smashed both sets of yards again. Shortly after the first attack on Rome one of the prime Allied objectives of the campaign was realized. Italy's dictator, Mussolini, was thrown out of power. The day after the second attack, Marshal Badoglio declared Rome an



open city. Three weeks later, on September 3, as a result of General Eisenhower's ultimatum that Italy must agree to all the Allied terms or suffer the full weight of Allied air power, an armistice was signed. Our intensive air offensive, combined with the skillful and speedy conquest of Sicily by Allied armies, had saved tens of thousands of lives and vast quantities of supplies and equipment.

One of the most spectacular missions of the war was carried out during this period of the Mediterranean campaign. After months of detailed planning, and weeks of careful rehearsal at a secret base in the North African desert, on August 1, 1943, a powerful force of Ninth Air Force Liberators (including three groups transferred from England for this purpose) swept over the oil refineries of Ploesti and Campina in Rumania, dropping great loads of bombs from altitudes of less than 500 feet. General Brereton described it as the greatest low level mass attack in history. The route covered more than 2,200



U. S. A. A. F. photo

#### THE RAID ON THE PLOESTI OIL FIELDS

This Rumanian oil center was a vastly important source of German fuel supply. Our Ninth Army Air Force stationed in the Middle East raided Ploesti, for the second time, on August 1, 1943. They used Consolidated Vultee B-24 Liberators. It was an unusually large raiding party. Our planes flew from 100 to 700 feet above the surface. This photo taken from one of the Liberators shows the Columbia Aquila refinery in flames. Fourteen of our Liberators are in this picture.

miles round trip. About 40 per cent of the oil refineries were knocked out, a bad blow to Germany which depended on those resources for half her oil supplies.

The first raid of the war against German Europe from North African bases was made on August 13, 1943, when a strong force of Liberators of the Ninth Air Force flew 1,200 miles each way high over the Mediterranean, across the mountains of Yugoslavia and the plains of Hungary, and dropped 150 tons of high explosives on the great Messerschmitt factory at Wiener-Neustadt, producer of some 250 ME-109s a month, wrecking the assembly plants and repair shops of one of Germany's most important fighter plane plants.

On August 25, our air forces made a triple-threat attack on the important Italian east coast marshalling yards and cluster of airfields at Foggia. In the morning over 100 Lightnings skimmed over the west coast of Italy and soon came over the treetops and blazed away at scores of parked enemy planes, mostly JU-88s. Surprise was complete and no enemy planes could get into the air. Then Axis gun emplacements were knocked out, and the railroad station, trains and trucks were hit. The round trip was well over 400 miles. Shortly after, Liberators from the Ninth Air Force dropped more than 60 tons of bombs, causing heavy damage to railway yards and bridges. The climax came when a huge formation of Fortresses, escorted by Lightnings, dropped nearly 250 tons squarely in the target area. Five weeks later the British Fifth Corps occupied Foggia, with its large bomber field and a dozen satellite fighter fields. This was the prize jewel of the entire Mediterranean campaign, and its possession makes our air ring around Germany considerably tighter and smaller.

Preceded by several days of continuous bombing by Allied air forces of rail lines and airfields along the entire length of the Italian boot, British and Canadian forces of the Eighth Army, supported by sea and air units, attacked across the Straits of Messina and landed on the Italian coast on September 3, 1943. During the next few days heavy attacks on similar objectives were made by Mitchells, Baltimores, Bostons and Mustangs of the Tactical Air Force, as Fortresses and Liberators, escorted by Lightnings, and Wellingtons, all of the Strategic Air Force, smashed communications in North Italy. The Allied offensive in the toe of Italy, the Calabrian front, went forward swiftly, and with the announcement of the capitulation of Italy, two new fronts were opened on September 9, 1943. British forces, the Eighth Army under Gen. Montgomery, undertook landing operations at Taranto on the east coast, and within a few days had control of Taranto and Brindisi harbors and a number of good airfields in that general area. On the Naples front, the Allied Fifth Army, British-American forces under Lt. Gen. Mark Clark, landed at Salerno. Gen. Harold Alexander was commander of all Allied forces in Italy.

The air battle of Salerno had started some weeks before. Heavy

and medium bombers had ruined airfields, pinned enemy aircraft on the ground and shattered fighter formations which rose to meet them. From the outset of the ground battle after the landing on September 9, the Allies maintained overwhelming control of the air. Fourteen different types of Allied aircraft participated. More than 2,000 sorties were flown in a single day. Under heavy German artillery fire, however, the position of our ground troops became critical, and our entire Strategic Air Force (including units of the Ninth) was thrown into the breach to help the Tactical Air Force. The tide was turned and the beachhead was saved. As General Spaatz summed it up, "Never before have bombs been employed on a battlefield with such telling effect." Two weeks later Naples itself was captured.

At this time the bombardment units of the Ninth Air Force were absorbed by the Twelfth Bomber Command. On November 1, 1944, it became the U. S. Fifteenth Air Force, headed by Major Gen. Doolittle. General Spaatz retained the overall command of the Twelfth and the Fifteenth. Major Gen. Brereton and some of the Ninth Air Force headquarters staff were transferred to England where they built up an American Tactical Air Force.

Uniting with Air Marshal Coningham's R. A. F. Second Tactical Air Force, the new organization became the Allied Expeditionary Air Forces, operating under Air Chief Marshal Leigh-Mallory, General Eisenhower's invasion air chief.

The Fifteenth was formed for the Italian campaign, and it was announced as a strategic air force. The Twelfth Air Force, under Major Gen. James K. Cannon, Coningham's deputy, became a tactical air force for cooperation with Gen. Alexander's ground forces in Italy.

The Fifteenth Air Force took off on November 2, 1943, on a 1,400-mile round trip attack against the Messerschmitt factories at Wiener Neustadt. Comparison with the 2,400-mile mission against this same objective in mid-August from bases in North Africa indicated the high strategic value of our new bomber bases in Italy. The second attack used less gasoline. More bombs were dropped. The attack was reported as highly successful. Another attack was made on October 24, during which heavy clouds covered the target area. Other missions of the Fifteenth during the next few weeks included the Turin ball-bearing works on November 8 and December 1; the vital Bolzano railroad bridge on November 10; enemy airfields near Athens, Greece, on November 15, on Toulon, France, on the 24th; Marseilles harbor and airfields, Bolzano and Orvieto bridges, and Arezzo, Florence, railyards on December 2; Messerschmitt ME-410 factory at Augsburg on December 19; Rimini railyards on the 28th; heavy attack on Reggio nell'Emilia railyards, aircraft factory and power station, with Lightning and, for the first time in this theater, Thunderbolt escort on January 8, 1944, and the Messerschmitt parts





U. S. Signal Corps photo

#### WHEN GERMAN AIR POWER HURT US

Burning ships in the harbor of Bari, Italy, after a German air raid on the night of November 2, 1943, when 16 Allied ships were destroyed.

factory at Klagenfurt, Austria, on two days, January 16 and 31.

The Twelfth Tactical Air Force, meanwhile had continued hammering away practically every day in cooperation with the slowly advancing Allied Fifth and Eighth armies. Enemy supply lines, including railway junctions, trains and locomotives, bridges, trucks, as well as airfields, supply and ammunition dumps were the subject of constant attack by our Mitchells, Lightnings, Mustangs and Warhawks and R. A. F. Spitfires. In addition, frequent missions were dispatched against enemy airfields and bases in Greece and the Balkans. There were several attacks on Sofia, which soon showed the Bulgarians that their capital was to become another war casualty.

Early in 1944, a new Mediterranean Allied air force began to take shape. Gen. Sir Henry Maitland Wilson succeeded Gen. Eisenhower as commander in chief of the theater, with Lt. Gen. Jacob L. Devers as his deputy. Lt. Gen. Ira C. Eaker replaced Air Chief Marshal Tedder as commander of the Allied Air Forces in the Mediterranean, his deputy being Air Marshal Sir John Slessor, to direct R. A. F. units. The U. S. Twelfth (Tactical) and Fifteenth (Strategic) Air Forces were under General Eaker's command. However, the actual

long-range strategic bombing operations against war industries in Europe by Major General Nathan F. Twining's Fifteenth Air Force were under the overall direction of Lt. Gen. Spaatz as part of the U. S. Strategic Air Forces in Europe (USSAFE). Thus were coordinated operations from south Europe with those of the Eighth Air Force, under Gen. Doolittle, from the United Kingdom. The all-out Allied air offensive by which German ability to resist would be destroyed was gaining momentum each week. Germany was receiving terrific pre-invasion punishment from the air.

Our forces in the China-Burma-India theater had been very small and inadequately equipped in the beginning of the campaign: and even after those conditions improved, there remained the great difficulty of bringing in adequate supplies from the western half of the world. Our Army Air Forces shared in these problems from the beginning; but they managed to set up a good organization: one which was to do increasingly effective work against the Japs on the mainland of Asia. Early in 1942, the Tenth Air Force had been organized at Patterson Field, O., and on March 2, it was officially on active duty in India. Major Gen. Lewis H. Brereton assumed command of this air force under the theater commander, Lt. Gen. Joseph W. Stilwell. Brig. Gen. Clayton Bissell was theater air officer. Considering the limitations as to equipment and other supplies, the Tenth Air Force made remarkable progress.

The theater itself was immense. It sprawled from Karachi, Indus River and the Punjab in the west, over the towering Himalayas and the Bay of Bengal and across Burma to Chekiang province in eastern China. In July, 1942, Gen. Brereton was transferred to Egypt to build up the Ninth Air Force; and a few weeks later Gen. Bissell was given command of the Tenth.

The Tenth Air Force included an India Air Task Force under Brig. Gen. Caleb V. Haynes, equipped with a few Liberator heavy bombers, Mitchell medium bombers and Warhawk fighter-bombers. The China Air Task Force, under Brig. Gen. Claire Chennault, was a part of the Tenth, and consisted of the 23rd Pursuit Group flying P-40s, commanded by Col. Robert L. Scott, Jr., and a Bomber Force, with a few B-25s, headed at the start by Col. Haynes and later by Col. Herbert Morgan. Another activity was the Assam-Burma-China air transport service. It was started about ten days before the fall of Mandalay. Under the direction of Col. William Old, assisted by Col. Earl Naiden and Major Emmett O'Donnell, Jr., our aerial Burma Road began operations from a small R.A.F. base near Sadiya, Assam. It was flanked on three sides by high mountains and tea plantations. Early in December, 1942, this heroic air shuttle service was expanded into the India-China Wing of the Air Transport Command. By January, 1943, our American system of air bases was spread fairly well over North and East India. It included a huge

supply and service depot with parts, maintenance facilities and personnel to keep planes flying to the limit, including major overhauls and repairs to planes from the China theater. The Air Service Command had done a magnificent job since its arrival in the field in May, 1942. First, second and to some degree improvised third echelon maintenance was carried on in the China area, largely by Chinese ground crews under American supervision.

Turning to combat operations, the Tenth Air Force had a typical day on January 10, 1943. Heavy and medium bombers effectively cut enemy communications between northern and southern Burma by bombing the central span of the Myitnge River bridge near Mandalay. Observers reported that the span was resting on the river bed when the planes withdrew. Throughout the rest of the month the Tenth and units of the India R.A.F. continued to bomb Japanese airfields, enemy-occupied villages and communications centers in Burma, and docks and shipping at Rangoon. On February 8, 1943, the largest number of bombers yet dispatched by the Tenth Air Force attacked Rangoon, inflicting heavy damage on docks and railroad yards. With the development of our air transport operations Japanese reaction set in. On February 25, American air bases in Assam were attacked by a strong formation of enemy bombers with fighter escort. Our fighters intercepted and destroyed six bombers and three fighters, with 20 more probably shot down. We lost no planes. Allied air attacks continued daily over widely scattered areas of Burma, the transfer of medium and heavy bomber operations from North India to the Calcutta area being a major factor in their increased effectiveness. This applied especially to the 2,000-mile B-24 missions against Bangkok and other targets in Thailand.

Meanwhile, more help for China appeared to be on the way. China was considered the ultimate base for the defeat of Japan. Directly after the Casablanca conference in January, 1943, General Arnold flew out to Chungking to see what could be done to give China more help in the air. Decisions on increased aid for China were made at the Chungking conference early in February, 1943, with Generalissimo Chiang Kai-shek, Generals Stilwell, Arnold and other military leaders. On March 10, shortly after Gen. Arnold's return to Washington, it was announced that the U. S. Fourteenth Air Force had been activated under Chennault, replacing the China Air Task Force. Two weeks later, Generals Bissell of the Tenth and Chennault of the Fourteenth were made major generals. The small stock of Mitchells in China was increased and plans were made to keep the supply line moving faster by adding a fleet of Curtiss C-46 Commando transports to the Douglas C-47 Skytrains which had been in use for nearly a year. The striking power and range also was stepped up considerably by the assignment of a heavy bombardment group of Liberators, commanded by Col. Eugene Beebe, which arrived about May 1, 1943.



The fighter force of Curtiss Warhawks was augmented by a squadron of Lockheed Lightnings in June, greatly increasing the speed, range and ceiling of fighter and fighter-bomber operations.

On April 4, 1943, Gen. Chennault announced that this unit, one of the smallest U. S. Air Forces in active combat, definitely had destroyed 182 Japanese planes and probably destroyed 63 more, with a loss of nine fighter pilots in actual air combat and another through bombing, besides sinking a considerable amount of Japanese shipping and inflicting heavy damage on enemy airfields and military installations in medium and fighter-bomber operations. In this latter connection, the P-40s with their sturdy construction and heavy firepower, plus their ability to carry 500-pound bombs, proved especially effective.

In Burma, the weeks before the 1943 monsoon saw increased enemy activity in the air, with many attacks on Allied airfields in eastern Bengal. The aerial offensive of the Tenth and R.A.F. also was stepped up. On April 4, 1943, our Liberators dropped 13 tons



U. S. A. A. F. photo

#### BLASTING THE JAP AT RANGOON

Our U. S. Army Tenth Air Force destroying Japanese shipping in Rangoon harbor on November 27, 1943.

of bombs on the Thilawa oil refinery south of Rangoon, which had been burned by the Allies a year before and then put back into operation by the Japanese. Heavy blows at railroad junctions, bridges and communications in central Burma were struck by Liberators, Mitchells and Warhawks. Not to be outdone by their colleagues over the "hump" in China, the fighter pilots of the Tenth Air Force tried out the P-40 with a 1,000-pound bomb.

On March 19, 1943, an important bridge near Mogaung, Burma, was hit with one of these "bridge buster" bombs by a Warhawk pilot, and from then on the bomb-carrying fighters had plenty of activity. Experience had proved that blasting away at the many bridges in central and upper Burma with 300 and 500-pound bombs was not very effective. Repair gangs and extra rails had the damage repaired and traffic moving within three days, and the job had to be done all over again. This time the 1,000-pound bombs were used, and they demolished the bridges completely. With the fighter-bombers able to drop heavy explosives, our Mitchell bombers were free for attacks on more distant targets. One of these was the vital Myitnge bridge south of Mandalay and on the main line to Rangoon. In eight attacks between January and April 15, more than 100 tons of bombs were dropped on it by our Mitchells and Liberators, many direct hits being scored. The Japs kept rebuilding it, but at no time was it in use. As fast as they repaired it, our bombers knocked it out again.

In these and similar operations, the bombardiers of the Tenth Air Force turned in some of the most accurate bombing of the entire war.

However, just as Vegesack on March 18, 1943, was a turning point in Eighth Air Force operations, owing to our highly successful use of the latest automatic flight control equipment, so its general use in Burma from April on greatly increased the effectiveness of heavy bomber operations of the Tenth Air Force. By its use the bombardier actually operated the plane during the bombing run, which could be cut down from 30 or 40 seconds to as little as 12 or 15 seconds. It also enabled a smaller number of aircraft to perform a mission. Thus all through May, until the heavy monsoon curtailed operations, the Tenth Air Force carried out widespread, damaging raids on Japanese communications and installations in Burma, including railroad yards, rolling stock at Toungoo, Mandalay, Prome and installations in Central Burma.

Arrival of a group of Liberator bombers in the China area during the first week of May, 1943, was the signal for an increased bomber offensive against important Japanese military centers. With Mitchell medium bombers and Warhawk fighters, successful attacks were carried out against heavily fortified Hainan island, off the South China coast, and the Hanoi-Haiphong area in Indo-China. This was followed a few days later by a big attack on the Tien Ho and White Cloud air bases near Canton, destroying some 20 enemy planes which

rose to intercept, and badly smashing up that important training and staging point for all Japanese air force activities for southeast Asia and the southwest Pacific. On these three missions more than 80 tons of bombs were dropped with a high degree of accuracy. This extended activity stirred up violent Japanese counter-attacks. On May 15 about 40 heavy bombers escorted by 40 Zeros attacked Kunming, headquarters base of our Fourteenth Air Force. Our Warhawks, with ample notice from Chennault's air warning system, prevented most of the Jap bombers from reaching the target, shooting down at least 15 and probably 10 more.

The revitalized Chinese Air Force also began to do an increased share of the fighting in the skies over China. A program to train Chinese aviation cadets in various schools in Arizona, notably Thunderbird and Williams Fields, had started late in 1941; and early in 1943, several hundred Chinese fighter and bomber pilots, trained according to U. S. Army Air Forces standards, were back in China prepared to fight the hated Jap invader. They were equipped for the most part with Curtiss Warhawks, Bell Airacobras, Lockheed Hudsons and Russian SB bombers. The best evidence of the revival of the Chinese Air Force and its promise of future potentialities was found in the first-class cooperation between the U. S. Fourteenth Air Force, Chinese air units and hard-fighting Chinese ground troops in a decisive victory in May and June battles where the Jap outnumbered them by at least 75,000. This disposed of a potential threat to Changsa, city of half a million and capital of Hunan Province, between the big Jap base of Ichang and Yochow on the eastern shore of Tung-ting Lake. Regarding the Chinese fighter pilots, General Chennault said, "You can't tell them from American fighter pilots when you see them in action." Later in the year a Chinese-American composite medium bomber Wing was formed, and many important missions were carried out in their Mitchells, with Warhawks or Lightnings escorting.

The appointment of Lord Louis Mountbatten as Commander-in-Chief of the southeast Asia theater, following the Quebec conference, coupled with the explicit and far-reaching statements at the Cairo conference some months later, indicated early and decisive action against the Japs even before the war in Europe should be concluded. During the last week of July, Major Gen. George E. Stratemeyer, chief of the Air Staff in Washington, was appointed commander of American air forces in India-Burma. Brig. Gen. Howard C. Davidson became commander of the Tenth Air Force. Major Gen. Clayton Bissell returned to Washington, to the important post of Asst. Chief of Air Staff, Intelligence, and in February, 1944, Asst. Chief of Staff, Intelligence (G-2) of the U. S. Army. In August the headquarters of the Tenth Air Force was moved from New Delhi to Calcutta, and a few days later 20 Liberators and 25 Mitchells carried out a heavy attack on Akyab, important Burmese port in the Bay of Bengal.



Throughout the rest of 1943, attacks by heavy, medium and fighter-bombers continued almost daily, keeping the enemy off-balance in the entire Burmese-Thailand area, and preventing his building up strong positions anywhere within bomber reach. A joint Tenth, Fourteenth and R.A.F. sustained air offensive was carried out during the last week of November. About the middle of December, Lord Mountbatten announced the formation of the Eastern Air Command, merging the R.A.F. in India and the U. S. Tenth Air Force into a unified air force, with headquarters in New Delhi. The commander was Air Chief Marshal Sir Richard Peirse, a champion of strategic bombardment. His deputy was Major Gen. Stratemyer.

Patterned after the highly successful Allied air organization developed in the North African campaign, the Eastern Air Command included a Strategic Air Force, headed by Brig. Gen. Davidson, and a Tactical Air Force, commanded by Air Marshal Baldwin. As operations developed, highly essential non-combat groups were to be organized, including aviation engineers, photo reconnaissance, air service and troop carrier units. By the end of the cold season in India, February, 1944, plans seemed to be under way for substantially increased action against the Jap in Burma and China.

General Chennault's Fourteenth Air Force, meanwhile, unofficially retained the name of "Flying Tigers" which had been the name of the American volunteer air group flying for the Chinese Government prior to our entry in the war, with Chennault as commander. Our Fourteenth Air Force kept after the Japs in China, giving the Chinese armies much needed air support, bombing strategic points whenever possible, including a heavy attack on Formosa on November 25, 1943, sinking enemy shipping and nibbling away at the Jap air force. Between October 1, 1943, and February 15, 1944, more than 175,000 tons of Jap shipping was sunk, with another 100,000 probably sunk or damaged—an enviable record in itself.

After the occupation of Kwajalein, when Admiral Nimitz announced his plan to drive across the Pacific and land air and ground forces on the China coast, General Stilwell stated that "such a plan must be heavily supported by an aggressive land and air offensive from the interior, and this we intend to do in spite of the existing blockade." Gen. Chennault declared, "It has been my conviction for many years that China is the logical place for the final defeat of Japan. For some time I have been endeavoring to push construction of air bases, airfields and operational facilities in China so we can accommodate a much greater number of transports to bring in a greater quantity of supplies for both aviation and ground forces to be used not only in driving the Japanese out of China, but also attacking them in Japan."

General Arnold, in his report of January, 1944, agreed that China is "our most effective base for aerial operations against Japan," and

then described conditions in that important war theater, as follows:

"Supply is our problem in China. To supply our growing air strength in that country has been perhaps the greatest single challenge to the efficiency of the Air Forces. Every item of equipment necessary for the maintenance and operation of our Fourteenth Air Force must be flown into China from the outside. That is the primary, fundamental fact of our present strategy in Asia. It may throw some light to consider this fact in terms of gasoline alone. In the round-trip over the Hump between Assam and Kunming, the C-87 transport now in use can deliver four tons of 100-octane gasoline. To do so, the airplane must consume three and a half tons of the same precious commodity. The crews of a heavy bombardment group in China must ferry over their own gasoline, bombs, replacement parts and everything else in their own B-24's (the C-87 is a converted B-24). Before this bombardment group can go on one combat flight, it must make four trips over the Hump. To perform one extremely dangerous mission, those crews must make four separate flights over the most hazardous mountain terrain in the world. Until such time as we conquer the territory and build the road into China, and/or capture a seaport, we must follow this procedure whether it is for 40 aircraft or 4,000.

"Our problem of making supplies flow into China by no means starts in Assam. When Major Gen. Lewis H. Brereton and his men first arrived in India from Java they found a total of 10 airdromes in that entire subcontinent. Until that time, the British defense of India



U. S. A. A. F. photo

#### WE STRIKE JAPAN IN FORMOSA

When our Fourteenth Air Force attacked Shinchiku airfield on Formosa, on Thanksgiving Day, November 25, 1943, our low level fighter attack, shown here, destroyed 35 planes before our bombers made their run.

had been based on the assumption that the only threat could come from the Northwest frontier—the Kyber Pass. The Japanese seizure of Burma suddenly threatened attack not from the Northwest but the East. A complete and rapid readjustment of defenses was in order, a formidable task in any country, let alone India. There, the enervating heat, the apathy of the natives, the total absence of modern methods and equipment, combined to form a staggering prospect.

“Assam is separated from the rest of India by the Brahmaputra, one of the longest rivers in the world, and one that has not a single bridge through its length in that country. Its mean level varies with the seasons. At certain times of the year, a 25-foot rise and fall puts river ports out of commission during both flood and ebb periods. There is no through-road between Assam and Calcutta. Rail transportation is complicated by changes in gauge, and the existence of antiquated train ferries. The capacity of the inland water system was for a long time even lower than usual because power units and barges had been moved to Iraq. And during the monsoon season, nearly all non-river transportation ceases because the area is completely flooded. The monsoon season lasts, in Assam, from mid-May to mid-November. The average rainfall is about 150 inches as compared to a 20-inch average for a similar period in, say, Virginia. Malaria is a constant threat. Life and labor are cheap in India. Sections of tea land were cleared for our airfields and runways were painfully built with rocks taken from the river bottom and carried in baskets on the heads of coolies. Antediluvian stone rollers, pushed by other coolies, were used to pack down the rock.

“Our flying transport operations are no less difficult. The pilots who fly our transports in that weather are as exposed as any in actual combat. 17,000-foot mountains have to be cleared by instrument flying. If our men veer to the North, they meet 22,000-foot peaks, while to the South they drift over Japanese-held Burma. It is no country to crash-land in. That is the route our supplies must travel after they have already been shipped more than 10,000 miles—supplies not only for our Fourteenth Air Force but to help equip the Chinese army and to build and defend China’s airfields.

“And yet the Fourteenth Air Force is in the skies over China. Under the command of a master tactician, Gen. Claire L. Chennault, American fliers of the Fourteenth have from February 2, 1942, to October 31, 1943, brought down 351 Japanese aircraft, with a loss to themselves of only 68, an unrivalled record. That is not counting enemy aircraft probably destroyed or damaged.

“A record of this scope is all the more impressive in that it was built up in the course of what is, by today’s standards, aerial guerrilla warfare. The pre-condition of all successful guerrilla operations—an actively friendly countryside—exists in China, and the Fourteenth has taken advantage of this by helping the Chinese create one

of the most efficient aircraft warning systems in existence. Our bases are notified of the approach of a Japanese flight almost at the moment it takes to the air. This warning system was one of the factors that enabled the Fourteenth to provide the support which helped to stop the Japanese cold in the Tung-ting Lake offensive of May and June, 1943.

"In its primary mission of protecting the terminal bases of air transport, the Fourteenth Air Force has been completely successful. At the same time, we know that air transport must be established for our Chinese bases. It need hardly be stated that we have no intention of allowing our air operations from the Asiatic mainland to remain on the level of guerrilla warfare. Neither Japanese shipping nor Japanese industry will survive the bombing in store for them."

March 10, 1944, was the end of the first year of Fourteenth Air Force operations, and Gen. Chennault made the following statement to the personnel: "Among the great Air Forces of the United States, the Fourteenth is still small. Yet we can claim achievement of which I believe a far larger force might reasonably be proud.

"We have defended against a far more numerous enemy almost the entire area of Free China. When the enemy has attacked, we have taught him how it feels to suffer losses of six or seven or eight or even nine for one. We ourselves have attacked repeatedly, with determination and with success. They know the sound of our aircraft, and of our bombs dropping on the Yangtze River, in Hong Kong and Canton and Amoy and Swatow, on Formosa, and in the Japanese-held ports and bases of Indo-China, Thailand, and Burma. Small as we have been and still are, we have made our attacks felt where it has hurt most. The sea routes between the Japanese islands and the Japanese Empire are the jugular of the Japanese military system. We have stabbed tirelessly for the jugular, and since March 10, 1943, we have certainly sunk 274,939 tons of enemy shipping, and probably sunk or damaged another 282,350 tons. Some may venture to predict that we shall cut the jugular and the organism will die. Finally, we have fought side by side with our Chinese Allies, again last summer, and were victorious. In the Tung Ting Lake camp in the Battle for Changteh last fall, we supported powerfully China's armies, who met the Japanese and drove them back.

"We can be proud of such a record. We can be proud also of the growth that has come during the last year. The 12 months from March 10, 1943, until today have seen the establishment of the Chinese American Composite Wing, in which Chinese and Americans live together, work together and enter combat together. The Chinese American Composite Wing's record will speak for itself. The same 12 months also have seen the establishment in China of the Air Service Command, to aid us in supply and maintenance; the expansion of our own fighting units, and their reinforcement with improved types of



aircraft, and the construction of new airfields and improvement of old. It seems a long time since the establishment of the Forward Echelon of the Fourteenth AAF. Yet it was only eleven months ago that four officers journeyed to Kweilin to prepare for the occupation of our bases in East China. Last summer, with a mere handful of planes, the Forward Echelon withstood a most determined Japanese attempt to wipe it out by force of superior numbers: and now the Forward Echelon has been replaced by two powerful wings.

"The 12 months to come will see, I am confident, a growth even more rapid, and successes even more remarkable. There have been hard times in the past. I, for one, will not soon forget the days last July and August when our men at Kweilin hung on only by their own courage and the magnificent determination of the ground crews to keep planes in the air against all odds. No doubt there will be hard times in the future. But we are on the offensive, not the defensive, now. Soon or late, the end is in sight. As your General, I cannot foretell the date of victory, but I will say to you that if you go on as you have started, you will bring measurably nearer the day when Japan has been humbled, and we can all make that homeward journey which we so desire."

Lt. Gen. George C. Kenney's Fifth Air Force in the southwest Pacific started 1943 right by winning the battle of the Huon Gulf. Between January 6 and 9, heavy, medium and light bombers and fighter-bombers, escorted by fighters, attacked a Jap convoy of two light cruisers, four destroyers and four transports, scoring seven direct hits and many near misses. Four ships were sunk, four probably sunk, one badly damaged; 80 to 115 enemy aircraft destroyed and 40 damaged. General Kenney reported that minimum altitude, or skip-bombing, used in this engagement, was undoubtedly superior to aerial torpedoes against ship and naval targets. Final resistance at Buna had ceased on January 3, and a pocket of very stubborn resistance between Buna and Gona was wiped out on January 23. The next day General MacArthur paid tribute to the remarkable part which the Fifth Air Force had played in the entire campaign to remove the enemy threat to Australia by clearing the Japs out of Papua and eastern New Guinea. Over 60 per cent of the troops were flown into the battle area and kept constantly supplied by air, while bombers and fighter-bombers blasted enemy supply lines and prevented reinforcements from the main bases of Salamaua, Lae and Rabaul from reaching the Japanese forces. He stated that a new form of campaign was tested which pointed the way by the use of "swift, massive strokes" to the ultimate defeat of the enemy in the Pacific.

The Jap was badly defeated in the Bismarck Sea. General Arnold in his report described it as follows: "The crew of one of General Kenney's bombers spotted a large Japanese convoy heading toward New Guinea on March 1, 1943. Thus began the battle of the Bis-

mark Sea. During the three days that followed, the crews of 162 Allied planes repeatedly attacked this convoy and its protective cover of land-based fighters. Allied heavy bombers destroyed many Japanese fighters while on the ground at their Lae, Finschhafen and Gasmata bases. Other bombers, medium and light as well as heavy, made attack after attack on the convoy with highly coordinated precision and mast-head skip-bombing tactics. Techniques of this sort had been developed in the course of months of hard, driving rehearsals. By March 4, the convoy had been smashed. Besides the enemy ships sunk, from 59 to 83 planes had been shot down and at least nine others damaged. Total Army Air Forces personnel losses came to 13. The Japanese lost approximately 12,700 officers and men. Entirely unassisted, the Fifth Air Force, besides disposing of large numbers of airmen and sailors, wiped out an entire division of troops. Thus the Fifth Air Force, operating in conjunction with our amphibious, naval and land forces in and around the Solomons and New Guinea, had seized the initiative in the Southwest Pacific. For the first time in that theater we were able to strike at times and places of our own choosing."

To attain this mobility of air power and to cooperate with the



U. S. Navy photo

#### A RAID ON GIZO ISLAND

U. S. Army Air Forces Fortresses bomb Japanese installations on Gizo Island in the Solomons.



U. S. A. A. F. photo

#### OUR PARATROOPS AGAINST THE JAPS

During the attack on Jap installations at Nadzab, New Guinea, on September 5, 1943, a regiment of our paratroopers were dropped from Douglas Skytrains while A-20s laid smoke screens and North American Mitchells bombed the enemy airfields. Photo shows one battalion in the foreground while another battalion is landing on the distant hillside.

ground forces in their advance up the New Guinea coast, forward airfields were built. Upon completion of the air base at Dobadura, fighters could escort the bombers, and the complete neutralization of Lae and Salamaua, both as air bases and seaports became possible. Building the base at Marilinan provided fighter cover for the great paratroop landing at Nadzab in the Markham Valley on September 5, 1943. Airborne engineers then were flown in, and when strips behind the enemy positions were completed, Salamaua and Lae were captured in a few weeks.

General Arnold described the Nadzab operations as "a remarkable achievement foreshadowing at least part of our pattern of victory in the Pacific."

"The landing at Nadzab," he continued, "put an end to the carping at our early 'palm tree-to-palm tree' advance. Here was warfare at 200 miles an hour. Our Fifth Air Force landed 1,700 American paratroops, fully equipped and supplied, plus 36 Australian artillerymen with guns.

"These operations in the Markham Valley are well worthy of note. In front, 48 B-25's opened the fight by strafing Japanese positions and dropping fragmentation bombs. They were followed by six A-20s that laid the smoke screen which covered the landing of our paratroops from the 96 C-47's. Above these flew five B-17's carrying materiel, and three B-17's with Generals MacArthur and Kenney and their staffs. A fighter escort of 146 P-38's and P-47's covered the

flight at various altitudes while at Heath's Plantation, halfway between Nadzab and Lae, four B-17's and 24 B-24's bombed and strafed the Japanese positions. Five weather ships operated along the route and over the passes to keep units posted on conditions. This was a far cry from the days when our decimated squadrons were being blasted out of the skies over Luzon.

"The day after the landing at Nadzab, the aviation engineer who had built the airfield at Marilinan, landed a Cub plane in the jungle and arranged for Australians and natives to prepare a strip for transport planes. This was the prelude to the arrival of two airborne engineer battalions, from Marilinan and Port Moresby, and the rapid construction of new airfields in the Markham Valley, behind the Japanese position at Lae which held out for 10 more days.

"Five weeks after the landing at Nadzab in the Markham Valley, we raided the Japanese stronghold of Rabaul. Our box score on that mission was three destroyers, three medium merchant vessels, 32 small merchant vessels, 68 harbor craft, 11 luggers and two patrol craft sunk or destroyed; one submarine, one submarine tender, one destroyer tender, one medium merchant vessel, badly damaged; 184 enemy planes destroyed or damaged. Our own losses were two B-24's, one B-25 and one Beaufighter. Our air superiority in the Southwest Pacific since has been definitely established."

After our Tsili Tsili air base was set up, the big drive on the major Jap air bases in the Wewak area began. There a very menacing concentration of enemy aircraft was being built up. One of the great factors in the success of skip-bombing and anti-shipping missions generally was the devastating power of the eight-gun North American Mitchell, developed by Lt. Col. William Gunn, under General Kenney, in this theater, and later, standard on the attack version of this medium bomber in many other theaters. There were eight .50-cal. machine guns in the nose, besides those in the upper and tail turrets and the two waist guns, 14 in all, plus one 75 mm. cannon. In the series of terrific tree-top attacks in the Wewak area and other enemy airfields, the Mitchells and Douglas A-20 attack bombers proved as devastating against land objectives as they were against shipping. In the Wewak mission, 309 enemy planes were destroyed during the last two weeks of August, 1943. From that time on similar attacks on enemy airfields were referred to as "Wewak-ing."

The all-out air offensive against Rabaul by the Fifth Air Force began on October 12, 1943. For more than a year, attacks had been made from time to time from Port Moresby; but this drive, coordinated with that of the Thirteenth Air Force and Naval air forces in the Solomons, was designed to neutralize completely this vital enemy base once and for all. On the 12th, about 300 aircraft of the Fifth attacked the Rabaul airfields and harbor, destroying 127 aircraft and inflicting heavy losses on enemy shipping. Five other attacks by



B-24s and B-25s, with P-38s escorting, followed between the 18th and 26th. On November 2, with Rabaul harbor filled with enemy shipping to relieve Bougainville, 75 Mitchells and 80 Lightnings delivered a crushing blow that will go down as one of the outstanding engagements of the South Pacific war. Between October 12 and November 11 Jap aircraft losses at Rabaul on the ground and in the air were more than 550 destroyed, 175 probably destroyed and 60 damaged.

After several months in the South Pacific, with Army air units scattered about in Fiji, the New Hebrides, New Caledonia and Guadalcanal, the Thirteenth Air Force was established in January, 1943, under the command of Major Gen. Nathan F. Twining, with headquarters in New Caledonia. The first Island Command also was set up under Major Gen. Rush Lincoln. Lt. Gen. Millard F. Harmon, formerly chief of the Air Staff was the overall commander of Army units under the theater command of Adm. William F. Halsey. The Allied strategy for 1943 became apparent a few days after the establishment of the Thirteenth, when on January 23, Munda was bombed heavily three times within five hours by bombers of the Thirteenth and Naval air forces. This was the first strategic enemy airfield north of Guadalcanal. It was under constant bombardment for the next few months until its capture on August 7, one year after the Marines had landed on Guadalcanal.

The Japs were now on the defensive at the fringe of their "outer empire" and they kept counter-attacking, despite very heavy losses in the air. One of their worst setbacks was on June 16, 1943, when they attacked Guadalcanal, by that time a very substantial air base with 120 bombers and fighters. Our Army, Navy, Marine Corps and Anzac pilots shot down 77 enemy planes, while anti-aircraft got 17 more, or 94 out of 120. Two weeks later, our forces occupied Rendova, seven miles from Munda. The Japs lost 101 bombers and fighters in savage counter-attacks. They lose 200 more during the first 10 days of our joint offensive against Munda. After Munda fell, it was converted into a huge air base for our continued drive against Rabaul. This was the right arm of our air pincers movement. The attacks by our Fifth Air Force from New Guinea and Cape Gloucester, at the lower tip of New Britain, formed the left arm.

Vella Lavella was next, bypassing Kolombangara with its airstrip at Vila, picking this up later. Throughout September and October, heavy attacks against the airfields at Kahili and Kara on Bougainville were made almost daily by Army Liberators and Mitchells, Navy Dauntless dive bombers and Corsair fighters. The strategic air and naval base on Buka Island, just north of Bougainville, also was under attack, as was Ballale Island, south of Bougainville, and Vila on Kolombangara. The escorting Corsairs and Lightnings were achieving notable successes against the best fighters the Japs could throw

against them, including the improved Zero, Type 1, called Hamp (square wings) and the still later Type 3, Tony, with inline liquid-cooled engine.

On the night of October 26, Allied troops landed in the Treasury Islands, 40 miles southwest of Buin, at the southern tip of Bougainville. Two days later, American parachute troops were landed from boats near Voza on Choiseul Island. Finally at dawn on November 1, marines made a surprise landing near Cape Torokina on the coast of Empress Augusta Bay, Bougainville. Allied planes on patrol intercepted small formations of Jap fighters, 25 of which were shot down during the day. Our AAF and Navy planes heavily bombed all the Bougainville airfields daily to keep them inoperative. This included a 90-ton attack by 25 Thirteenth Air Force Liberators on

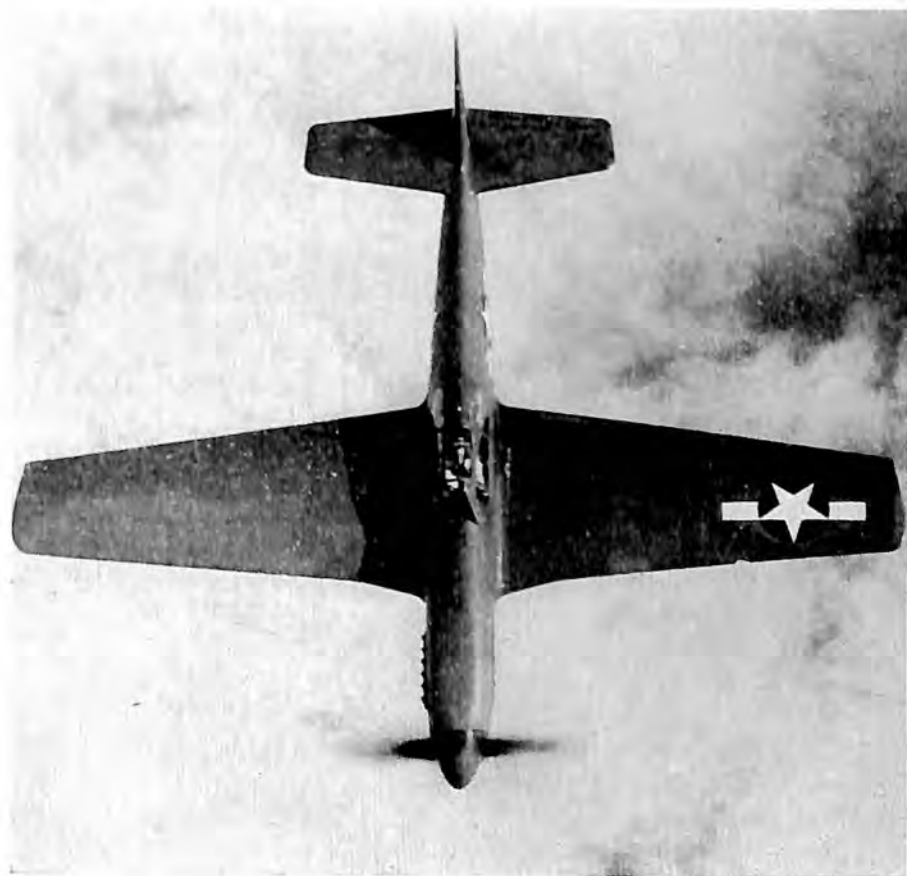

#### THE NORTH AMERICAN MUSTANG

North American Aviation's P-51 Mustang fighters equipped with Packard-built Merlin engines went into action for the first time when they escorted heavy bombers on a raid deep into Germany on January 5, 1944. Earlier models of the Mustang with Allison engines were the first single-engine airplanes to penetrate Germany from British bases in this war.



U. S. A. A. F. photo

#### ONE OF OUR RABAUL ATTACKS

This photo was taken on November 2, 1943, during attack by bombers of our Fifth Air Force. It was only one of repeated attacks made on Japan's great base in New Britain.

Buka. Allied air supremacy in the entire area continued practically unchallenged, except for occasional night attacks by enemy bombers. By early December, 1943, our 4,000-foot Torokina fighter strip was ready to send fighter sweeps over Rabaul, and on Christmas Day the Piva Field, with its 6,500-foot runway, was dedicated. This important airfield, carved out of the jungle by Navy Seabees, was handling light and medium bombers early in 1944. Less than 250 miles from Rabaul, it also was only 850 miles from the heavily fortified Japanese naval base of Truk, in the Carolines.

Christmas week saw the completion of the Solomons campaign which began on August 7, 1942, at Guadalcanal, by the seizure of Green Island by Anzac troops from Gen. MacArthur's command and Naval units from Admiral Halsey's forces. The possession of this island, at the northern tip of the Solomons, about half way from New Ireland Island, effectively cut off about 22,000 Jap troops remaining on Bougainville, Buka, Shortland and Choiseul Islands. They were faced with starvation or surrender.

The Seventh Air Force, commanded by Major Gen. Willis Hale, and based in Hawaii, was also on the offensive, despite the immense distances involved and the fact that the crews of land planes had to make exceedingly long over-water flights. Pin-point navigation was to be at a premium in the operations of the Seventh. In December, 1942, some units had moved down into the South Pacific, and joining with others already there, they became the Thirteenth Air Force. The Seventh itself, however, later played an important part in the Central Pacific drive of Naval air and sea power which burst into such dramatic successes in early 1944. Wake had been one of their early targets. A few days before Christmas, 1942, two dozen Liberators had paid a surprise midnight visit to that outpost, inflicting heavy damage. It was the longest offensive mass flight ever made, over 4,000 nautical miles, with Midway the only stopping point. In March, 1943, American forces, including units of the Seventh Air Force, occupied Funafuti, largest of the Ellice Islands. On April 20, one of the hardest blows delivered by American heavy bombers against the enemy in the Pacific was carried out when a large force of Liberators blasted the Jap phosphate works on the circular island of Nauru in the Gilbert Island group. A dozen B-24s attacked this important target again in mid-September and again about the end of November, after Nanumea had been occupied, a base also in the Ellice group but nearly 200 miles nearer the Gilberts. They made another attack on Wake from Midway on July 24, starting many fires and destroying several Zeros.

In September, 1943, in conjunction with Naval carrier task forces, the Seventh Air Force began its air offensive against the Gilberts, striking Tarawa, Makin and other targets in preparation for the amphibious operations to come. The attacks were made from Funafuti, Nanumea and also from Canton Island of the Phoenix group. From the middle of November, 1943, until the end of January, 1944, the Seventh Air Force dropped more than 3,500,000 pounds of bombs on Japanese bases in the Marshall Islands preparatory to our Marine Corps invasion. The Seventh's targets included Jaluit, Mili, Wotje and Kwajalein, as well as Tarawa and Makin in the Gilberts, before they were occupied by our Marines. Early in 1944, the striking power of the Seventh Air Force was increased and given variety when A-24 Dauntless dive bombers and B-25 Mitchell mediums, with the new rapid-firing 77 mm. cannon, and Warhawk fighter-bombers, took their places with the long-range Liberators. The terrific pounding this team gave the enemy bases in the Marshalls was a major factor in the masterstroke which seized Kwajalein early in February, 1944. They continued to play an important part, with Naval air and sea forces, in the great Central Pacific drive.

The map shows that one of the shortest roads to Tokyo runs from Alaska down the Aleutian island chain. There were two enemies to





U. S. Signal Corps photo

#### DURING THE ALEUTIANS CAMPAIGN

Major Gen. Simon B. Buckner, Jr., commanding the Alaskan Defense Command, gets time to read his mail during a flight over the Aleutians early in 1943.

fight, the Japs and the weather. Weather in the Aleutians means fog, that hides airfields and volcanoes rising from the sea. It also means cross winds and cold rain that starts to fall in Siberia but lands in the Aleutians. Despite all obstacles, American air, ground and Naval forces drove the Japs out of their Attu and Kiska strongholds. From Aleutian bases the U. S. Eleventh Air Force several times bombed Paramushiru in the Jap Kurile islands.

The headquarters of the Eleventh Air Force, commanded by Major Gen. William O. Butler was located at Anchorage, with forward bases at Kodiak, Cold Bay and Umnak, the latter the secret base which saved Dutch Harbor in June, 1942, when the Japs tried to destroy the port. One by one, American air bases were built in the Aleutians despite enormous problems of terrain, weather and supply. These bases stopped the Jap aggression in that area, and they also provided means for our offensive air operations. In September, 1942, a new base was occupied in the Andreanof islands, 250 miles east of Kiska, which permitted fighter escort for the few bomber raids possible during autumn and winter. On January 13, 1943, American troops, including aviation engineers, landed on Amchitka, 85 miles from Kiska and 750 miles from Paramushiru. By February 16, an

airfield was ready. By April, our bombing operations, with Liberators, Mitchells and Marauders, were more than doubled. Lightnings, Airacobras and Warhawks flew fighter escort and often operated as low-flying fighter-bombers. In April and May Kiska and sometimes Attu were raided six or eight times a day, weather permitting. Combined sea, land and air operations started against Attu on May 11, 1943, with Navy pilots lifting their dive bombers and fighters off a baby carrier, converted from a freighter, through fog so dense they could not see the bow end of the flight deck. During May, the Eleventh Air Force flew 47 missions against Attu, dropping more than 225 tons of bombs, and 74 missions against Kiska. Attu was won on May 20, 1943. The unfinished 1,000-foot runway was enlarged and completed, and other airfields built. Attu became a bomber base which brought our striking air force within 630 nautical miles of Paramushiru.

On July 10, 1943, Eleventh Air Force Liberators and Mitchells sank enemy shipping midway between Attu and Kamchatka peninsula, and on the 19th, seven weeks after the capture of Attu, our far-reach-

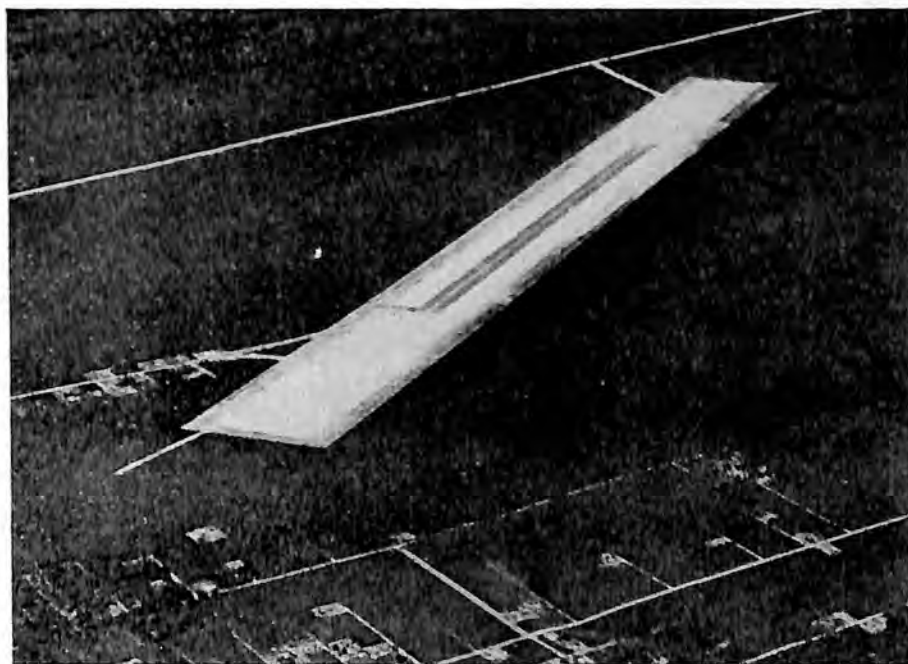

U. S. A. A. F. photo

#### ONE OF THE AIR FORCE'S FLIGHT STRIPS

A view from about 4,000 feet of a standard-size Flight Strip constructed for use by airplanes up to gross loads of 80,000 pounds. The paved runway on this Flight Strip area lies in the direction of the prevailing wind. The adjacent highway can be seen extending along part of the length of one of the shoulders. Turf grown on both shoulders has sufficient bearing strength to hold a heavy bomber taxiing in wet weather.

ing B-24s took off from Amchitka, bombed Kiska, flew on to Attu, reloaded and then went on for a reconnaissance and strike mission against Paramushiru. It was the first blow on Japan's home grounds since the Doolittle raid; but not the last. There were several others. Paramushiru promised to become one of our own air bases along our road to Tokyo.

Under the supervision of Col. Stedman Shumway Hanks, Army Air Forces officer who first conceived the idea of flight strips for emergency landings, 24 such strips were completed in 14 States. During construction of the strips, at least 10 emergency landings were made by military pilots who were running out of fuel in bad weather. Eight other flight strips were constructed in Canada near the Alaskan Highway, and they proved of great value to the Army Air Forces in ferrying aircraft to Alaska, because pilots were doing contact flying. Flight strips promised to be of the utmost future value along both domestic and international highways; and 17 States had recent legislation providing for construction and maintenance of such strips in cooperation with the U. S. Public Roads Administration.

On February 28, 1944, the War Department announced that "the need of the Army Air Forces for training planes has been met, and termination of existing contracts for such aircraft has been ordered to insure use of the employees involved in the construction of combat aircraft. In terminating the contracts the Army Air Forces will have on hand a quantity of incompleated fabricated parts. It is anticipated that a portion of this supply will be absorbed as spares in maintenance of present trainer planes."



U. S. Navy photo

AT ONE OF OUR BASES IN THE SOUTH PACIFIC

A Navy Consolidated Vultee PB<sub>2</sub>Y Coronado long-range flying boat comes in for a landing. An American warship is at the left, a cargo vessel on the right.

## CHAPTER IV

### U. S. NAVAL AVIATION AT WAR

**T**HE aviation forces of the United States Navy were smashing the enemy on many fronts in 1944, forging steadily ahead in the series of impressive victories which, starting with the decisive Battle of Midway in 1942, helped mightily in maintaining the initiative for the United Nations. Our Naval Aviation in 1944 was the most powerful and unquestionably the most effective Navy air force in the world. More than 27,000 trained pilots, over 20,000 warplanes, 40 new aircraft carriers added to the Fleet—these were only a few of the more striking tokens of strength which accounted for the increasing success in every quarter that our Navy aviators attacked. At the beginning of 1944, more than 2,000 new planes were being delivered to the Navy every month, accompanied by all the auxiliaries essential to the rising tempo of the Navy's offensive, particularly against the Japanese.

In 1943, Naval Aviation had played a vastly important role in the most bitterly fought of ocean campaigns, that of the Southern Solomons where the Allies succeeded in holding their own against the most tenacious efforts of the Japanese. One of the most glowing chapters in the history of American air power was written in those skies; and it was followed immediately by our offensive aimed at the subjugation of Rabaul and Truk, the two main outposts of the Jap who had to hold them if he was to defend his homeland from successful attacks from sea and air. The Gilbert and Marshall Islands were scenes of equally important victories in which Naval Aviation paved the way by softening enemy objectives in air campaigns that went on for weeks and months preparatory to invasion by our surface forces. Naval Aviation shared with the Army Air Forces the arduous task of driving the Jap out of the Aleutians and then participated in the vitally strategic destruction of Jap installations on his northern home front, Paramushiru in the Kuriles. Naval Aviation was active in the Sicilian and Italian invasions. It also participated in raids on Norway. It patrolled our thousands of miles of coastline, and escorted our convoys over the seas; and our Navy fliers had their full share in stifling the menace of enemy submarines. Further, our Naval Air Transport Service sped vital supplies and key personnel to the distant fronts.

Our Naval Aviation had assumed two main tasks with regard to Nippon. One was to shatter her air power. The other was to help our surface forces destroy Jap surface power on both land and sea. There was no halt in the frightful effectiveness with which both objectives



were carried out, dating from the decisive Battle of Midway where Japan lost four aircraft carriers, all the planes on these ships, nearly all the crews and the best among Jap naval airmen. Events proved that Japan could not recover her Naval air strength lost at Midway. It was the beginning of the end. As our Naval Aviation grew in size and constantly demonstrated superior strength, Japan's decreased in both size and strength, as the records prove.

Of our new carriers, six were of the big, 27,000-ton Essex class. An outline of the full weight of fury to be loosed by Naval Aviation was afforded late in 1943 when Secretary of the Navy Frank Knox announced that three new 45,000-ton carriers would be constructed. That finally vanquished the carrier critics. The flattops—mobile flying fields which carried the war to the enemy throughout the last third of 1943—had performed miracles. The projected 45,000-ton giants were to have increased compartmentation, heavier armor and greater armament. Long-range, slugging twin-engine aircraft were to be their main batteries in smashing the enemy harder and from greater distances. How completely the carrier vindicated itself is most convincingly seen in the fact that between October, 1942, and the end of 1943 only one American carrier was sunk. This was the *Liscome Bay*, a baby flattop. During that period, Air Groups flying from carrier flight decks in every major Naval engagement of the war took an incalculable toll in men and dollars from the enemy.

Realization of the full importance and necessity of a huge, hard-hitting, well-trained Naval air force, if the war was to be won in the shortest possible time, was expressed by Admiral Ernest J. King, Commander-in-Chief of the United States Fleet and Chief of Naval Operations—himself an aviator—when he created the post of Deputy Chief of Naval Operations for Air, and named to that key job Vice Admiral John Sidney McCain, guiding air genius of the early days of the historic Guadalcanal campaign. A foretaste of things to come was afforded when, on the 30th anniversary of Naval Aviation, August 30, 1943, Admiral McCain disclosed that huge task forces, spearheaded by aircraft carriers, were poised in the Pacific about to strike sledgehammer blows at the enemy. At the time Admiral McCain made his statement, Vice Admiral John H. Towers, Commander of the Pacific Air Force, had reported that air supremacy had been wrested from the Jap in the South Pacific. He disclosed that Navy and Marine Corps flyers, operating from Guadalcanal, had so decimated the Jap's South Pacific air force that it was forced to operate on a "fire engine" basis; that is, it had to shift its limited number of planes over the half-moon of its long defense line to meet Allied attacks, and therefore was unable to attack opportunity targets.

A new conception of warfare, based on the potency of air power, gained dominance during 1943, as the United Nations high command increased the effective employment of warcraft almost daily. A tacti-

cal reorganization of Naval Aviation was carried out to make aircraft the mainspring of every Naval striking force. In November, 1943, Admiral C. W. Nimitz, Commander-in-Chief of the Pacific Fleet, announced: "Our time has come to attack!"

On the next day a carrier task force devastated Marcus Island, less than 1,000 miles from Tokyo. That was the first in a series of smashing raids and offensives which still were gaining increased momentum and ferocity early in 1944. The Jap was on the defensive, if not on the run, throughout the Pacific.

In the ever-angry, storm-tossed Atlantic, Naval Aviation played a decisive role in turning the tide of war in favor of the United Nations. There the submarine, with which the Germans had planned to throttle the Allies' supply line from the United States, was virtually driven from the seas for weeks at a time. High United Nations councils considered this a most significant development in view of Germany's admission, reflected through public statements by her leaders both in this and the first world war, that if she could not prevent supply of the European war fronts from the United States, she was lost. Late in 1943, it was disclosed officially that, in the sixth month May-October period, 150 German submarines definitely had been sunk. This equalled or surpassed Hitler's submarine production. Of this number, 56 were sunk by United States forces; and 43 of the under-sea raiders were sent down by Navy planes and flyers. In addition, Naval Aviation gained assists, with Army planes and Naval surface vessels, on three more subs destroyed.

The Atlantic shipping picture at the beginning of 1943 had been



U. S. Navy photo

#### ASLEEP ON THE DEEP

About 2,500 Navy enlisted men lie wrapped in sleep on the hangar deck of a U. S. Navy carrier. The men are being ferried from San Francisco to a Pacific base.



U. S. Navy photo

## ON A CARRIER IN THE PACIFIC

While ordnance men work on heavy bombs in the hangar deck of a new U. S. Navy aircraft carrier, and aviation machinists' mates adjust parts on Grumman Hellcats, officers and men in the background get relief from "sea-tension" by watching a movie.

black indeed. Navy patrol planes—Consolidated Catalinas, Martin Mariners, and Vought Kingfishers—were waging a valiant, but losing fight against the sub. Their determined crews were flying endless patrols through all kinds of weather, and were keeping the sub below the surface, where it operates at a disadvantage, in many instances. But these craft, ideal for many functions, were too slow to dive on, and bomb, submarines between the time they sighted them, and were themselves sighted, and the 30 seconds which elapsed before the submarine could crash dive. In the second place, the "convoy graveyard," that 600-mile middle stretch of the Atlantic, was beyond their range. As a result, the U-boats still were reaping a ruinous toll of shipping carrying vital supplies to the war fronts.

Into this discouraging situation suddenly, about mid-year, was injected a new, "secret" weapon by the Navy. Merchant ship sinkings began declining, rapidly. First inkling of the nature of the new weapon came with news of the sub-busting activity of a small aircraft carrier—a "baby flattop"—in the mid-Atlantic stretch. Carrier B, as it was identified, had been assigned to protect convoys. She had sunk

two submarines and probably sunk eight others. Considering the conservatism of Navy sub-sinking claims, Carrier B probably destroyed at least half her probables. The actual striking weapons were Grumman Avenger torpedo bombers and Wildcat fighters. These aircraft, which already had enviable records in the Pacific fighting, operated in teams of two—one fighter, one torpedo bomber—against the sub. Searching over small assigned areas, these planes when they spotted a sub had the speed to get down on the enemy before he could submerge. The fighter went screaming in, spraying the sub's decks with a hail of machine gunfire, thus keeping the deck gun crews from reaching their weapons. Following closely, the Avengers dropped their lethal charges. Photographs taken automatically from the attacking ships brought back the evidence—geysering debris, huge oil slicks, bodies dead and alive in the water.

Carrier B was a harbinger of the end for the submarine. Before year-end, many other baby flattops had proved that their small air groups, comprising a dozen fighters and a dozen torpedo planes, were the answer to the submarine. Possibly the most famous was the Card which, along with its destroyer escorts, sank more submarines than any team in Naval history. The exact number was not disclosed, but after the Card's first few cruises, it became nearly impossible to find a submarine in the Atlantic. Significant of the trend in the Atlantic warfare was the fact that when the baby flattops first set out, their mission was to protect convoys from subs; but by the time the Card's aviators achieved fame, the baby flattops were being sent out as "killer



U. S. Navy photo

#### BLASTING A WOLF FROM THE NAZI PACK

In July, 1943, Navy planes of escort carrier "B" while guarding a convoy across the Atlantic fought 11 German submarines. Taking off from, and landing on the little carrier, which was a converted freighter, they scored two "sure kills," four "very probables" and "four probables." No vessel in the convoy was lost.





#### MARTIN NAVY MARINER

These big two-engine flying boats were active in anti-submarine work and as Navy transports.

groups," to hunt the sub wolf packs and destroy them, while the convoys proceeded on their courses unmolested. Of the 43 German submarines destroyed by Naval air crews, 30 were blasted to bits by aircraft from these ugly duckling baby flattops, whose construction had been criticized by many who had said the small, slightly-compartmentated, lightly-armed craft would be unable to defend themselves against the torpedoes of the very prey they sought. Of the carriers, only the *Liscome Bay* had been sunk or seriously damaged at this writing early in 1944.

The remaining 13 submarines of the Navy total were sunk by the Mariners and Catalinas, aided immeasurably by two new patrol types acquired by the Navy during the year. These were the Lockheed Ventura and Consolidated Liberator, both land plane types adapted from Army designs for anti-submarine work. These planes, along with the North American Mitchell, another land plane bomber adapted for Navy use, were playing important war roles, in long-range patrol as well as anti-sub and other functions. They were answering a question which had been perplexing during the first year of war; namely, how could enemy surface forces not only be detected successfully, but shadowed exhaustively and reported. The workhorse Catalina, famed

patrol, anti-sub and rescue plane, of necessity had limitations in each function. This great ocean airplane, which accomplished such miracles as helping to stop the Japs in their 1942 Aleutian drive by dive-bombing the enemy fleet at Kiska, could find the enemy, but did not have the speed, maneuverability or defensive armor and armament to prevent its own destruction before its crew could obtain comprehensive facts on the enemy force's disposition, strength and apparent mission. Many a Catalina radioed a report of "large enemy force sighted," gave the position, and then went silent, her crew heroic victims of enemy interceptors or anti-aircraft fire. The Liberator, Ventura and Mitchell, land planes all, and entirely unsuited to any mission requiring landings and take-offs at sea, had the speed, maneuverability and fire-power to stick with an enemy force for hours and get the facts back to their bases, whence heavy striking forces could be dispatched to smash the enemy.

Throughout the campaign to open the Atlantic supply lanes and keep them open, the Navy's lighter-than-air fleet provided notable assistance. The blimp pilots and crews maintained their enviable record of having lost but one ship to German submarines since the start of war.

Even the thousands of finely-trained aviators and air crewmen turned out by the Navy could not have compiled the year's sterling

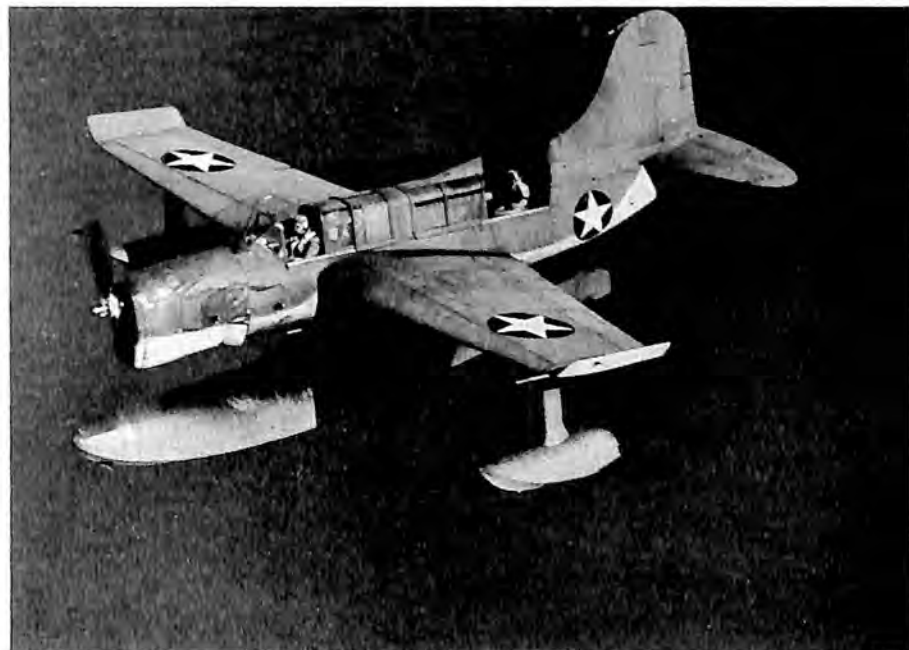

U. S. Navy photo

#### THE CURTISS SEAGULL

The Navy SO<sub>3</sub>C scout observation plane, catapulted from battleships and cruisers and operating as gun-spotter for the Fleet, also in coastal anti-submarine patrol.



U. S. Navy photo

#### OUR ATTACK ON THE MARSHALL AND GILBERT ISLANDS

During one of the raids in which our carrier-based bombers struck at the island of Wotje, shown here, one of eight Japanese bases in the Marshall and Gilbert Islands. The picture was taken from a Navy scout plane during the raid.

record of achievement without the topnotch equipment provided by the American aircraft industry. While 1942's planes carried on the splendid performance, which had established them as the most rugged in the world, the nation's plane builders came through with three outstanding new warplanes, which by early 1944 gave the Navy the most modern and savage carrier striking force of all the belligerents. As the many new carriers, spearheading their task forces, ranged the Pacific in 1944, their Air Groups, equipped with these new planes, were spoiling for a conclusive fight in which the Japs, quite understandably, were loath to indulge. The Grumman Avenger which was speeded to the Fleet in time to participate in the Battle of Midway, was the first. It was a torpedo bomber. Inevitably, many of its abilities—increased range, greater explosive load, higher speed—were limited by the comparable abilities of its teammates. In March, 1943, the next member of the team arrived. It was the Vought Corsair fighter with a 400-mile-an-hour speed, a 35,000 foot-plus ceiling, a 1,500 mile-plus range and armament able to deal death and destruction in quantity. Here was a real teammate for the Avenger. All that was needed was a superior dive bomber to permit the Navy's aviators to execute a devastating coordinated attack on enemy surface forces,

in which the fighters strafe enemy personnel away from the deck guns, the dive bombers follow immediately down the gunbarrel of controlled descent, after which the torpedo bombers flash in, a few feet above the water, from all points of the compass to drop their deadly "fish," while the enemy's anti-aircraft defense is still pointed skyward trying to ward off the steel hail falling from above. Meanwhile the fighter ranks were strengthened further by another superlative plane, the Grumman Hellcat, big brother to the plane revered by the defenders of Guadalcanal and the veterans of every big 1942 battle—the Wildcat. With the Corsair, the Hellcat gave the Navy the two finest ship-based fighters in the world, either of which could hold their own with any fighter in the world, ship- or land-based, on almost any terms.

The third member of the trio for which the Fleet waited was a new dive bomber—the Curtiss Helldiver. Its performance elated everybody except the enemy. In the raid on Rabaul, Japan's "little Pearl Harbor" in the South Pacific, on November 11, 1943, the Helldiver accounted for the bulk of the damage wrought, damage that made that enemy stronghold unfit for use as a major base. This plane, first dive bomber to carry its load fully-enclosed, had enough speed, range and lethal power to keep up with its teammates. This was to make Naval Aviation utterly destructive in 1944.

The South Pacific campaign had begun modestly in the early



U. S. Navy photo

#### NAVY CARRIER PLANES RAID BUKA

During the raid made by the Saratoga carrier task forces on November 1, 1943, Buka airfield was blasted as was Bonis runway, upper left, across Buka Passage.





U. S. Navy photo

#### NAVY CARRIERS APPROACH WAKE ISLAND

Showing two new carriers of the Essex class, the armada prepares to launch its planes against Wake Island in the raid of October 5, 1943, where our dive bombers and torpedo planes blasted Jap shipping and shore stations.

months of 1943, with Navy and Marine Corps flyers smashing Jap installations in the Northern Solomons almost daily from American bases in Guadalcanal and elsewhere in the Southern Solomons. Huge United Nations supply bases were completed further South, in Espiritu Santo and elsewhere, in preparation for part of the big push that began on June 30.

The Japs had tried to stop us when two weeks earlier on June 16, they flew a huge armada over Guadalcanal in an attempt to smash Allied forces gathering for the push northward. This attempt resulted in a signal victory for Naval Aviation. Seventy-seven enemy bombers and fighters were shot down over Guadalcanal in that one day. Then, on the 30th, Rendova Island, seven short miles from the partly completed Jap air citadel at Munda on New Georgia Island, was taken. That day marked what was probably the most bitter air battle of the Pacific warfare. One hundred and one Jap planes were destroyed as the Nips tried frantically, but unavailingly, to break up the task force which was landing Marines and soldiers on Rendova. Fourteen American planes were lost, but the pilots of 10 machines were rescued.

During the next 37 days, Navy dive and torpedo bombers shuttled up from Guadalcanal to Munda twice daily, a 400-mile round trip, to support the advance of the ground troops by bombing the airfield and the Jap troops. A tribute to the effectiveness of this and prior bombing was the fact that the Japs never were able to operate planes

from Munda. That strategic field was captured on August 7, one year to the day after the initial invasion of the Solomons. Within a few days, American warplanes were operating from the air strip which our Navy bombs had kept the enemy from completing. Capture of Munda and the rest of New Georgia was the first step in a series of advances northward. Soon Vella Lavella was taken, several other Jap islands being bypassed in the process, to be mopped up later. Other Jap strong points, such as Vila and Kahili on Kolombangara, were immobilized by constant bombings.

By this time the Japs had only one stronghold left in the Solomons, the island of Bougainville. The bombing shuttle began again, and within two months Bougainville was invaded. That made available airfields from which Rabaul could be attacked. Westward, General McArthur's Army Air Forces and ground troops, conquering Salamaua, Lae, Finchhaven and other key points on New Guinea, provided the other prong of the pincers to close on Rabaul, prime objective of the campaign. Japanese plane strength was weakened by the combined assaults of our Army and Navy flyers, and enemy



U. S. Navy photo

#### HOT WORK AT HENDERSON FIELD

Ground crews, working with assembly-line precision, are shown here loading 500-pound bombs into a Navy Grumman TBF Avenger during our 1943 offensive in the South Pacific.



U. S. Navy photo

#### DOUGLAS DIVE BOMBERS

The Navy SBD Dauntless dive bombers are shown here on the take-off from the deck of a carrier during the South Pacific campaign.

pilot quality decreased steadily as hundreds of Nip flyers were killed. Rabaul received terrific punishment from our fliers. Carrier-based aircraft, however, were to strike the final, crushing blows at Rabaul.

Meanwhile, Naval Aviation was helping mightily with another vital objective—expulsion of the Jap from the Aleutians. There, in the “worst flying weather in the world,” the enemy had dug himself in on Attu and Kiska in the year which had passed since he had taken those islands. American forces had not been idle, however. Bases had been established secretly at Amchitka and elsewhere, and early in 1943, intensive bombing of both Kiska and Attu began. Hundreds of raids were made and then, in early May, landings were made on Attu. Kiska was bypassed. The battle for Attu raged bitterly for 10 days. The Japs, dug into their ice-and-snow foxholes, fought savagely. Air support for the American forces was difficult to provide, because of the impossible weather.

Army aircraft based on Amchitka were almost completely unable to operate over the 165-mile distance to Attu. Moving silently through the blinding fog and snow in the ice caked waters off Attu's shore was one tiny carrier—one of the then untested baby flattops, carrier A. This ship's small air group provided virtually all the air cover for the invasion. Slithering off the ice-coated flight deck, Grumman Wild-

cats and Grumman Avengers lifted into the fog which shrouded even the end of the deck and nosed up and down the perilous, mountain-enclosed valleys of the island, bombing the Japs out of their foxholes, silencing the enemy's gun emplacements and supporting advancing American troops. Once, when the Japs landed troops and supplies behind the American soldiers, thereby cutting them off, Carrier A's planes arrived in the nick of time, slaughtered the Japs, sank their landing barges and destroyed their supply dumps. Battling the dread Aleutian williwaws, gusty 50-knot gales which tossed their planes up and down 1,000 to 2,000 feet in a few seconds, five Naval Aviators, including the Group Commander, out of the little band of Navy flyers, lost their lives—but Attu was taken.

A few weeks later, after the same standard bombing treatment, Kiska fell, and the threat to continental America which had existed for many months existed no longer. Notable in the fall of Kiska was the fact that when American troops finally made beachheads, they were surprised by lack of opposition. Thorough search failed to turn up any Japs whatsoever. The enemy apparently had realized the hopelessness of his position and, his morale shattered by the constant bombing, had slunk away.

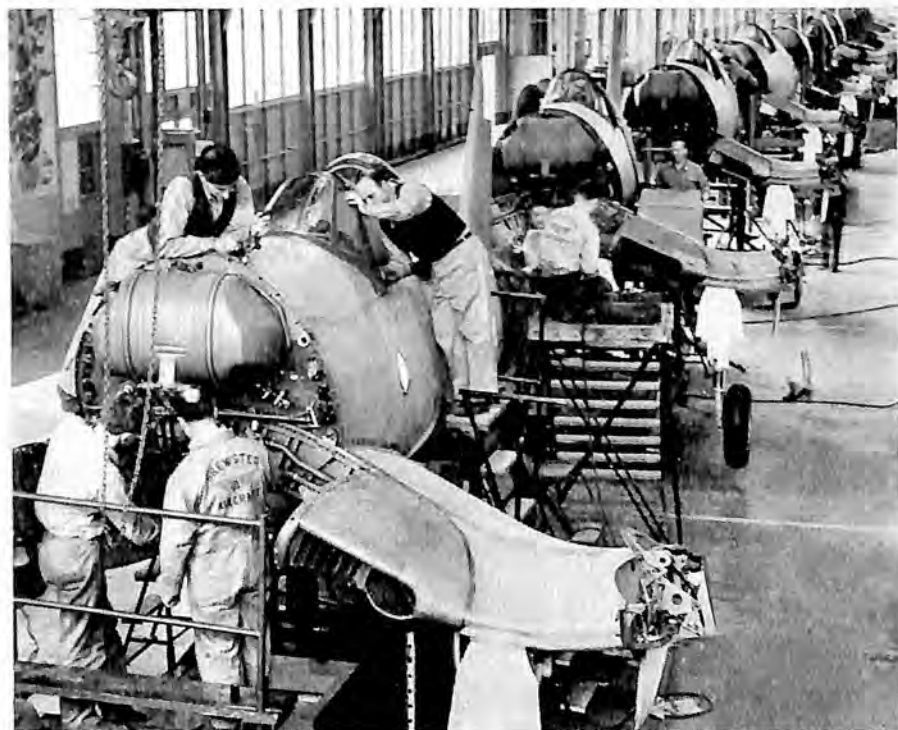

#### PRODUCING NAVY FIGHTERS

Corsairs on moving assembly line at Johnsville, Pa., plant of Brewster Aeronautical Corporation.





U. S. Navy photo

#### VENGEANCE AFTER THE JAPS

A formation of Grumman Avenger torpedo bombers on a mission against the Japs in the South Pacific.

By August, 1943, the tide was turning swiftly for the Allies. The enemy had been driven from the Aleutians, and from the Solomons. The pattern of assault upon the Japanese became obvious. From the Aleutians an attack could be made through the Kuriles, the Jap islands approximately 500 miles north of the mainland. Another campaign was starting in the Solomons and New Guinea, aimed at Rabaul and Truk. Already Allied bombers were sweeping over New Britain, trying to obliterate four big enemy airfields defending Rabaul.

There was to be a third campaign. Back in 1942, within two months of Pearl Harbor, the Navy's small carrier force had struck boldly at the Jap's holdings in the Marshall Islands and other central Pacific strongholds. The Navy knew that these island forts would have to be taken before the Jap could be defeated. It knew it had no chance of taking them in 1942, but realized the wisdom and necessity, even then, of slowing up their further fortification against the day when invasion should be feasible. Through these islands—the Marshalls, the Gilberts and others, lay the central road to Truk and Tokyo. The 1942 raids had been preliminaries to a campaign in which our augmented carrier fleet was to function as a prime attack force. On September 1, 1943, Marcus Island, less than 1,000 miles from Tokyo, was raided by a large American carrier task force. It was a daring venture, this taking carriers within reach of land-based bombers. It was apparent that the Navy had gained much strength before making such a challenge.

The Marcus raid was the opening salvo of the Navy's new main battery—airplanes from carrier. A complete tactical reorganization

had been effected. Huge task forces, centered around two and three carrier divisions, were ready in the Pacific. They were ready for a fight to the finish with the Jap fleet, if that fleet should show itself. The three gallant battle carriers which constituted the Navy's entire strength early in 1943, no longer had to run incredible risks to stab at the enemy—when they weren't running from him. Six new, huge flattops were with them now. So were nine cruisers converted into carriers, and a large number of baby flattops.

It was a large number of these carriers—at least as large as had been included in any carrier task force in history—which had sent their Air Groups against Marcus. The Jap was taken completely by surprise. Before he could get his fighters into the air, his runways were a shambles and his planes afire from strafing fighters and bombing by Douglas Dauntlesses and Grumman Avengers. Back on the carriers, ears were glued to the battle radio for first word of the expected arrival of the Jap's land-based planes. The Jap did not appear. Our Navy planes returned for more fuel and bombs, with news that Marcus had been rendered prostrate, helpless to defend itself. Off went the attack groups, again and again, throughout the day, to

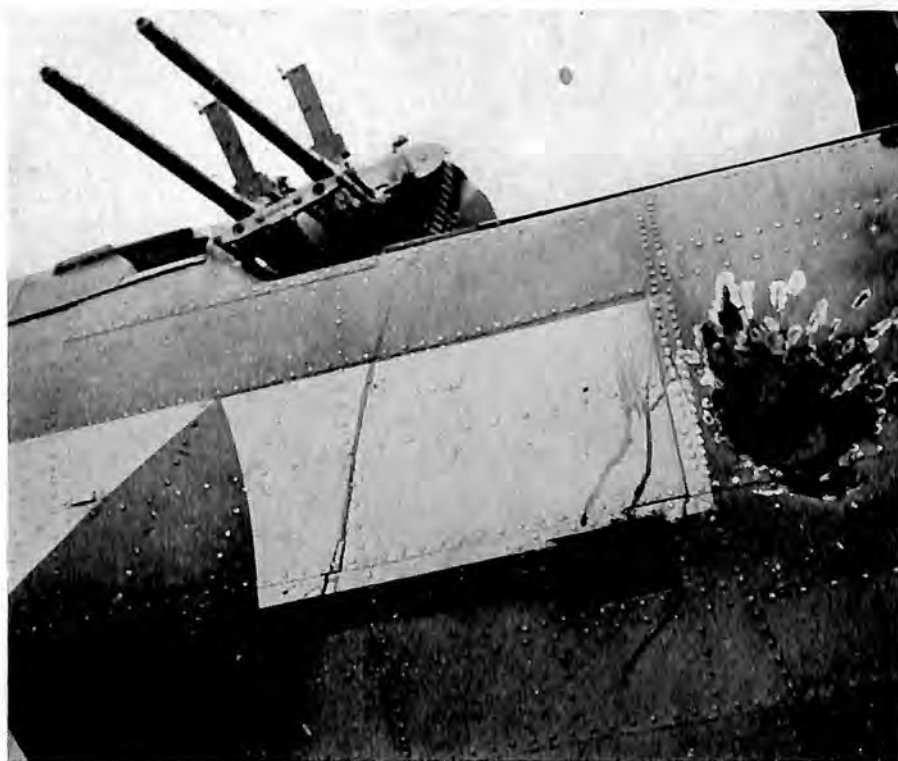

U. S. Navy photo

**RESULT OF A 20 MM. SHELL**

The gunner in this Navy bomber was killed by a 20 mm. shell from a Jap Zero during the raid on Rabaul on November 5, 1943.



U. S. Navy photo

#### THE GRUMMAN HELLCAT

The Navy's new carrier-based fighter F6F which proved more than a match against Jap fighter squadrons in the South Pacific campaign. Photo shows the Hellcat landing on the deck of a carrier.

devastate the island. Eighty per cent of the Marcus installations were destroyed. It was in this raid that the new Grumman Hellcat fighter made its debut. Its strafing of Jap shore installations was savagely effective, but because it met no aerial opposition, its complete test by fire was postponed.

The Marcus raid signalled the opening of a ceaseless campaign against the Jap in the Central Pacific. The carrier task forces were never idle. Many of their strikes were merely nuisance raids. Others were full-scale raids designed to immobilize important enemy island strongholds. Others cleared the way for actual invasion and occupation of Japanese strongholds.

Seventeen days after the Marcus raid, a carrier task force's planes raided Nauru and Tarawa in the Gilberts. Two steamers, many small vessels of the type which provided the Jap with his chief means of troop and supply transport, and nine parked bombers were wrecked, as were the installations. Only four American planes were lost.

On October 6 and 7, 1943, raids were made on Wake Island, that formation of coral atolls astride the approach to Midway Island, 1,000 miles distant. For this smash, the Navy put together the largest carrier task force in history, far stronger than that which had struck Marcus. This time the Japs were more alert. Strong forces of Zero



planes rose to intercept our raiders, but unavailingly. Thirty enemy planes were shot down, and 31 others were blasted to bits as they tried to take the air. A record-breaking 700 tons of bombs were dropped on the island by carrier-based planes, and by Consolidated Navy Liberators which followed our ship-based aircraft.

Indicating its growing aggressiveness, this task force was within easy striking distance from Japan's Marshall Islands for four days. The enemy made several attempts to batter through our Hellcat fighter screen, but not one of his planes got through. As our cruisers and destroyers steamed in close enough to pump shells onto Wake Island for two hours, waves of Hellcat-escorted Dauntlesses and Avengers made 830 bombing sorties over the island. Oil stores were set afire. Warehouse districts were destroyed. A large barracks burned to the ground. Three power and two water distillation plants, prime targets, were damaged. The enormous flotilla was commanded by Rear Admiral Alfred E. Montgomery, a pioneer Naval Aviator. Wake was blown into uselessness for months, at a cost of 13 of our planes.

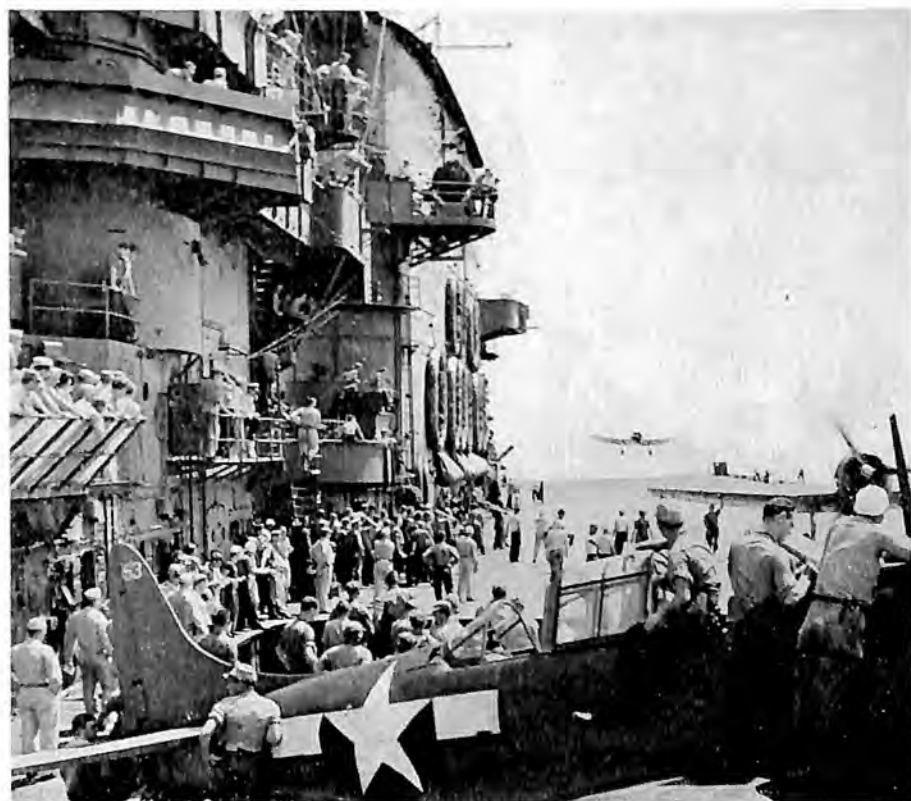

U. S. Navy photo

FLIGHT DECK OF THE SARATOGA

Scene on board the famous carrier during the raid on Rabaul on November 5, 1943.





U. S. Navy photo

#### MARTIN MARINERS FLY DOWN TO RIO

These Navy flying boats were guarding convoys to and from Brazil. They are shown here over the harbor of Rio de Janeiro.

There was to be no rest for the Japanese. The scene switched to the South Pacific where, on November 1, 1943, a carrier task force led by the veteran carrier *Saratoga*, knocked out the key Jap airfields at Buka and Bonis on the northern tip of Bougainville, a short distance from Rabaul. They were vital to defense of that citadel. This was the beginning of real trouble for Rabaul. Four days later, the *Saratoga's* task force descended on Rabaul harbor with unparalleled fury. As 70 Jap Zeros fought desperately to drive them away, our dive and torpedo bombers hit five cruisers with torpedoes and bombs, one cruiser with bombs, torpedoed two destroyers and strafed a dozen more destroyers. One heavy cruiser blew up in a flash of bright yellow flame. Our Hellcat fighters meanwhile were ripping into the Zeros, shooting down 26 for sure and getting 22 probables. The harbor was a scene of utter confusion, as the Jap ships wheeled madly to evade American missiles, and tried futilely to break through the harbor mouth into the open sea. The area was a mass of smoke and flames when our Navy planes left. The blow was so staggering that later, when Army planes arrived to strike their shore installations, the Japs could rally only 20 Zeros to combat them. Throughout the Navy attack, our carriers landed, fueled and armed their planes for new sorties against the harbor, without detection by the enemy.

Another destructive blow was aimed at Rabaul six days later. This time a carrier force equalling that used against Wake was sent into action. One light cruiser was sunk, as were two destroyers. Eight destroyers were damaged. In the air battle over the area, our Navy fighters shot down 24 Jap interceptors. This time, the Japs found our task force and sent four successive waves of bombers out to destroy the carriers, including the doughty *Saratoga*. Not one plane got through our American fighter screen. Sixty-four were shot down, 54 of these by one squadron of Hellcats alone. It proved the effectiveness of ship-based aircraft against land-based bombers seeking to destroy carriers. The Japanese, however, continued to pour planes into the Rabaul area regardless of losses, and continued to send down ships to be sunk or badly damaged.

Reasons for the smashing victories were: American planes had heavier fire power, improved engines, offered greater protection to their pilots, were more maneuverable and could take an unbelievable amount of punishment and still get home. American operational technique, involving teamwork under tutelage of battlewise instructors also was an important factor in the victories. Reconnaissance a few days after the second battle showed there were only eight ships



**THE GRUMMAN AVENGER**

Navy torpedo bomber which proved so effective in all engagements with the Japanese Navy.



#### THE GRUMMAN GREY GOOSE

Utility and patrol amphibian used by the U. S. Navy, Army Air Forces and Coast Guard in remote regions.

of all types left at Rabaul which previously had harbored hundreds of enemy vessels. General Arnold, commanding the Army Air Forces, wired the Navy:

"Please accept congratulations from the entire Army Air Forces for the outstanding air attack. The record by your airmen for damage per bomb and torpedo established a mark that all airmen can only strive to equal."

The campaign to drive the Jap completely out of the South Pacific continued full blast. Invasion and capture of New Britain seemed inevitable. Our southern forces were reaching inexorably for Truk. The Navy's workhorse flying boat, the Consolidated Catalina patrol bomber, watched the Jap with an untiring eye. Twice, within four days, they had attacked Jap ships, causing a 9,000-ton cargo ship to be beached, and hitting a cruiser with a 1,000-pound bomb which exploded in the ship's vitals.

With the South Pacific campaign going favorably, the Navy high command turned its attention once more to the Central Pacific approaches to Tokyo. On November 16, 1943, a carrier force's planes raided Tarawa in the Gilberts again, and Mili and Maloelap in the Marshalls. An airfield, barracks and oil dumps were battered. Two days later, 90 tons of bombs were dropped by carrier-based planes on Nauru.

The campaign in the Central Pacific continued. Ten barges were destroyed at Tonelei in a November raid. In addition, a cargo ship and eight barges were damaged, eight buildings were fired and two fuel dumps were destroyed, without American loss. On November 23, 1943, came the next big American smash. A carrier task force steamed silently within range of Tarawa, chief Jap base in the Gilberts. Air Groups were launched quietly before dawn and within two hours the invasion was on. First the fleet bombers smashed the Tarawa installations, then covered the beachheads established by the Marines after the bitterest fighting in the history of that gallant Corps. Seventy-two Jap planes which sought to bomb the invaders were shot down by the planes from three carriers. The Air Group from one got 46, a second Group blazed 16 of 20 attacking Jap fighters out of the sky, while a third Group destroyed 10 out of 15. Only four Hellcats and one Avenger were lost in all—an 18 to 1 victory ratio. After the beachheads were secured, part of this task force's planes supported the advancing Marines, while part of the carrier force planted itself between the Gilberts and the neighboring Marshalls, to repel expected counterattacks from those Jap strongholds. These attacks materialized, but all were thrown back. In the bombardment of Tarawa, more than 700 tons of bombs were splashed on the square-mile key pin-



BEECHCRAFT AT-7 TRAINER  
Equipped with Edo floats.



point, Betio airfield. Throughout the invasion, the Air Groups from this mighty task force rested not a moment, night or day. One thousand planes took part in the action.

It was in the Tarawa battle that Commander Edward O'Hare was lost. When 40 Jap torpedo planes slipped in at night to try and sink our carriers, O'Hare, now a squadron commander, led his men off the flight deck in pitch blackness to repel the Nips. The Jap torpedo planes were beaten off, many of them sent blazing into the sea. But O'Hare did not come back. Rear Admiral Arthur W. Radford, another Naval Aviation pioneer and commander of one of the task forces, said: "O'Hare saved my formation from certain torpedo hits. I am recommending him for a second Congressional Medal of Honor."

Late in 1943, Secretary of the Navy Knox announced that 12 new carriers and 2,000 new planes had been delivered to the Navy in the month of November. That was bad news for Japan. The noose around Truk was being tightened. The Pacific offensive was gaining real momentum. The Marshalls, lying just north of the Gilberts, were to be the next objective. In less than two weeks after the Gilberts invasion, our carrier planes were striking again. Kwajalein, Wotje, Maloelap, Mili and many other bases in the Marshalls were hit hard. The attack came on December 4, 1943, just three days before the second anniversary of the treacherous Japanese attack on Pearl Harbor. Four Jap bases were blasted to rubble by the Air Groups from at least four carriers. Two Jap cruisers and 72 airplanes were destroyed. Upwards of 300 Navy warplanes struck into the heart of the Marshalls to score one of the most brilliant victories in two years of Central Pacific warfare. Laboriously-built enemy defenses on Wotje atoll and on the islets of Kwajalein, Ebeye and Roi in Kwa-



GRUMMAN WIDGEON

These utility amphibians were used in coast patrol and other vital operations by U. S. Navy and Coast Guard.

jalein atoll, largest of the Marshalls, were turned into a shambles. In Kwajalein lagoon an oil tanker and three cargo vessels were sunk, along with the two cruisers. A troop transport and two cargo transports were damaged at the same place and one cargo transport was hit at Wotje, 160 miles east. Only three of our Navy planes were lost. One American carrier sustained damage, but was able to withdraw successfully at the good speed of 20 knots. The Jap sent strong

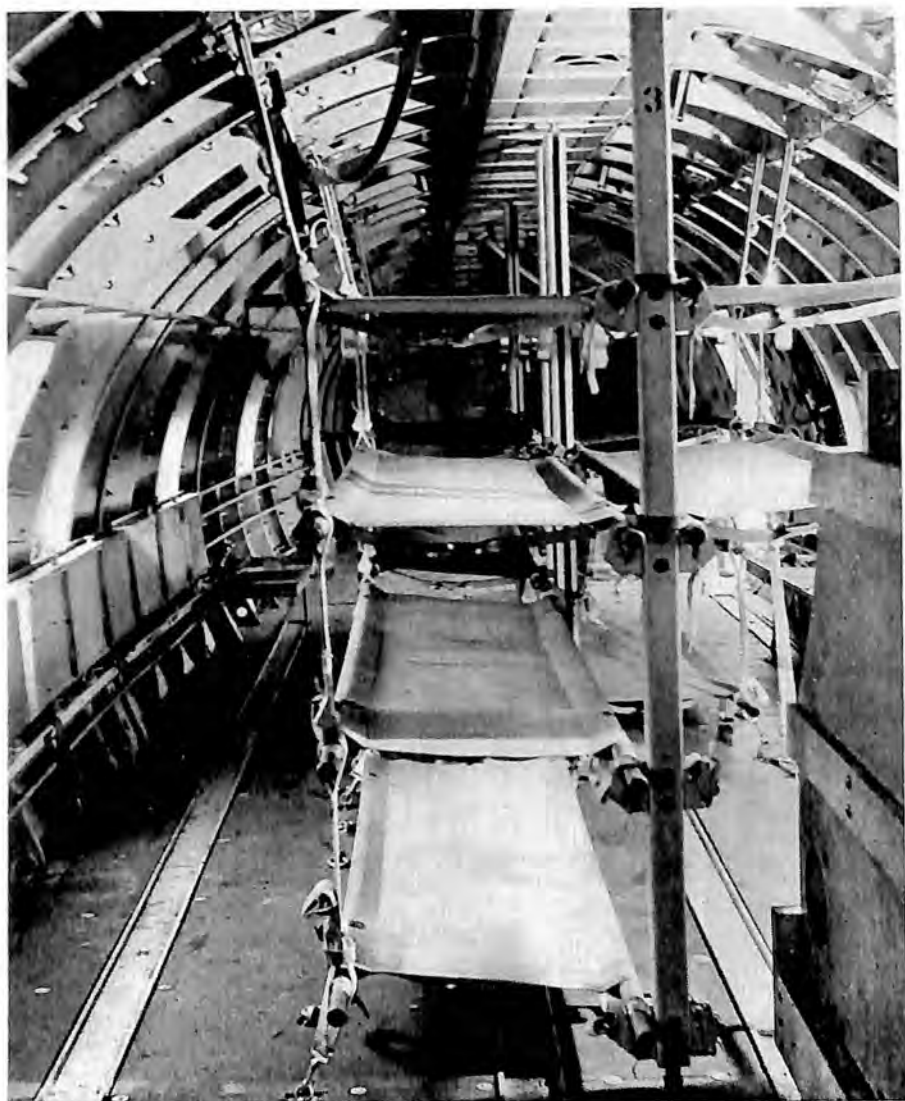

#### CURTISS COMMANDO AS HOSPITAL SHIP

In emergencies, the Curtiss C-46 Commando, made by the Airplane Division of Curtiss-Wright, could be fitted as a hospital ship and flown to the rear, loaded with badly injured. On regular schedules it hauled tons of war cargo to far-off fronts, and was in service with the Army, Navy and Marine Corps air forces.



N. A. C. A. photo

#### N. A. C. A. WIND TUNNEL TEST

Model of a Navy seaplane—The Martin Mars—mounted on the balance of the seven by 10-foot wind tunnel in the National Advisory Committee for Aeronautics laboratory at Langley Field, Va. Model tests of this nature are of value for indicating stability and control characteristics and also for determining the effect on the aerodynamic characteristics of the various components of an airplane.

forces of attacking bombers and torpedo planes against the American carriers but, with the exception of the damage inflicted on the one carrier, the enemy thrusts were futile.

As the American attacks on the Marshalls grew in intensity, it appeared that the reeling Jap was still committed to defensive warfare, and had decided that his best chance for victory lay in fighting a war of attrition, which he hoped would grow so long as to force a peace drive in the United States. No major units of the Jap fleet had been seen. No Jap aircraft carriers had been seen throughout the entire year, despite the merciless punishment dealt out by American carriers. Early in 1944, the American carrier forces actually were daring, publicly inviting the Jap to come out and fight, firm in the belief that such an engagement, or series of engagements could end the war with the Nips more quickly.

The year wound up in a rising crescendo of attack. Four days after the Marshalls strike, our carrier planes lashed out at Nauru again, in a third major blow at that base. Significance of this tiny spot in the Pacific was its position, which permitted the Jap there to keep watch on the United Nations supply line. It was figuratively the "eye on Truk." Nauru, like some of the other islands, had to be kept subdued in order to assure secrecy for our operations in that theater of war.

The Navy's flyers celebrated Christmas by raiding Kwajalein, Mili, Wotje and Maloelap again. One Jap troop transport was sunk. The December 25th raid marked the 17th consecutive day that the Marshalls had been hit either by our Army or Navy planes. On Christmas Eve, Nauru was hit again, its installations left in flames. Navy flyers were active elsewhere on Christmas Day, too, sinking a destroyer and two 10,000-ton cargo transports and damaging a destroyer. This punishment was inflicted in the South Pacific by Admiral Halsey's flyers.

New Year's Day, too, was a busy one for our Navy pilots. Planes from a carrier task force raided Kavieng Harbor, one of Rabaul's protective points. Thirteen Jap planes were destroyed. Three 1,000-pound bombs were sent into the vitals of a heavy cruiser, while a torpedo went crashing through the hull of the same vessel. Two bombs and two torpedoes crashed into another heavy cruiser. A destroyer received a 1,000-pound bomb hit, while another destroyer was thoroughly strafed. The three heaviest ships that were hit burned fiercely.

The far-reaching achievements of Naval Aviation had helped cast a black shadow of retribution in the direction of Tokyo. There were countless instances of individual heroism, of incredible gallantry on the part of Naval airmen, pilots and crewmen alike. The many new carriers, their hundreds of fighting men welded into precision-smooth fighting machines in the few short months that most of the personnel had been out of civilian life, cannot be identified, for strategic reasons, until some future date. But together, man, ship and plane, they



#### MARTIN MARS IN FLIGHT

The 140,000 pound Navy flying boat was powered by four 2,000 h.p. Wright Cyclone engines.





#### NORTH AMERICAN TRAINERS

AT-6 Texan combat trainers manufactured by North American Aviation at its plant in Dallas, Tex. They were used by both the Army and Navy and by many South American air forces.

fashioned a story of accomplishment unparalleled in naval history. All these men wanted, flyer and ship's company alike, was a real opportunity to meet the full Jap strength under any conditions. As Rear Admiral DeWitt Clinton Ramsey, Chief of the Navy's Bureau of Aeronautics, declared early in 1944: "We are ready. Just let the Jap come out and fight. He cannot afford to trade us ship for ship. The final phase of the war will be bitter and bloody, but the sooner the Jap can be brought to a conclusive engagement, the smaller will be our losses, the sooner the war will be over."

The handwriting on the wall must have been plainly visible to the Jap as 1944 began. The Marshalls were doomed to fall, thus opening the way for an East to West drive on Truk. New Britain Island, with Rabaul, had been invaded by Army troops at several points, under cover of Allied air power. The Army, valiantly led in initial assaults by the Marines, was moving inexorably on Rabaul. Rabaul, key holding on the island, was doomed. When New Britain fell, the way would be open for the South to North smash at Truk. Off to the northwest, Dutch airmen were beginning to pound the East Indies daily from the air.

The year 1943 brought many developments, including a revolution in strategic thinking, in Naval Aviation. Among these developments was the conclusive shattering of the cherished theory that carrier-based aircraft were inferior to land-based planes. Possibly the most telling argument in this connection which was furnished by war experience was the solid five-to-one victory ratio rolled up by carrier planes against Jap land-based aircraft. Allowing for the declining quality of Jap pilot material, and the fact that American planes were superior to the Japanese product, this overwhelming ratio still proved conclusively that carrier-based aviation was a long way from oblivion. In fact, the American victory ratio had increased, until early in 1944 many individual actions showed a 10, 15 and even 20 to 1 American superiority.

That Naval Aviation was destined to play a decisive role in the Japanese war had never been questioned. Early 1944, however, began to give strong indication that the Navy's flyers also would have a lot to say in the final knockout of Germany and her European satellites, in addition, of course, to the blows they dealt the German submarine



#### THE BOEING ARMY-NAVY TRAINER

Named the Caydet, Army model PT-13D, Navy model N2S-5, was built by the Wichita Division of the Boeing Airplane Company.

during 1943. In 1944, several Naval air patrol squadrons were operating in the European theater. Their presence there, and the fact that they were making a real contribution in the effort to bring an early surrender of Germany, was disclosed late in 1943, in reports of two actions. In the first, the British Admiralty revealed the participation of an American carrier in task force raids on a German convoy in Norwegian waters. On December 29, it was announced that two American Naval flyers, piloting a Liberator, had spotted a German merchant ship in the Bay of Biscay, escorted by 11 German destroyers. The American feat enabled Allied sea and air forces to sink three of the destroyers, damage several of the others, and destroy the cargo ship.

The Navy flyers fighting in the war theaters were supported in splendid fashion by the Naval Air Transport Service, which enjoyed a sensational growth in 1943. Starting the year with three squadrons, NATS grew to 10 squadrons, operating in three Wing organizations, with headquarters on the East and West Coasts and in Hawaii. By year-end, NATS was hauling key personnel and critical items to the fighting fronts and to the Fleet over more than 70,000 miles of airways, a network far larger than that flown by all the U. S. air lines before the war. The pilots of NATS carried out duties in many ways more difficult and harrying than flying a fighter or a dive bomber. Day after day, over thousands of miles of trackless ocean, these men, and their crews guided huge, complicated multi-engine aircraft to their destinations. They carried every conceivable item to the fighting forces, from a three-ton gear pinion which enabled a disabled cruiser to get back into the fight to the 13,000 pounds of Christmas mail which the Service's enormous new flying boat, the Martin Mars, hauled non-stop over the ocean 4,375 miles to Natal, Brazil, whence it was transhipped to the Mediterranean. On this, the Mars' first war mission, all records for cargo transportation and overwater flight were smashed. Twenty-three thousand pounds of materials vital to America's war production program were brought back to this country. On one leg of the return flight, 35,000 pounds of priority materials were carried from Belem, Brazil, to Port of Spain, Trinidad. Twenty additional flying boats of the Mars type were ordered early in 1944.

The Navy's lighter-than-air forces, too often overlooked in the breath-taking vision of 400-mile-an-hour fighters diving on each other, carried on their invaluable work of guarding merchant convoys and spotting submarines. The blimps had a record of having lost but one merchant ship to a sub since the war began.

Admiral King made a statement the day before the year ended, the significance of which cannot be overestimated. The Admiral, who directed the fortunes of the Fleet from the beginning, said that strategy for the defeat of Japan had been determined, that the Navy would like nothing better than to get the Japs into a showdown fight, that

he did not see how the Japs could launch an offensive in the Pacific in 1944, that he believed Germany could be defeated in 1944, and that "unremitting pressure on Japan will be continued and increased."

Operationally a part of the Navy, as always during wartime, the U.S. Coast Guard continued to use its planes and aviation personnel in conjunction with the overall operational plans of the Navy and the Sea Frontier Commands. Its aviation division during 1943 underwent considerable expansion both in the number of planes acquired and the number of personnel trained for aviation duties and assigned to air stations. The Coast Guard had nine air stations in the United States. They were operated in close association with the Sea Frontier Commands, one patrol squadron outside the continental limits of the United States and various independent units outside the United States. An air patrol of the Great Lakes, to facilitate icebreaking operations, was also in operation during the icebreaking seasons.

The use of Grumman amphibians in making surveys aided Coast Guard surface craft by directing them to the most vulnerable areas in their task of clearing passage through the ice for ships carrying ore to feed America's war industries. This thorough aerial survey gave the Coast Guard and the Great Lakes shipping industry the most complete picture of pre-season ice conditions that ever has been avail-



U. S. Navy photo

#### SEEKING JAP PLANES OR SHIPS

A Navy Consolidated Vultee Catalina over the Aleutian wilderness.





#### THE CHANCE VOUGHT F4U-1 CORSAIR

One of the most effective Navy and Marine Corps fighters, the Corsair was powered by a Pratt & Whitney 2,000 h.p. engine and was in the 400 m.p.h. class.

able. The height of aviation activity over the Great Lakes was reached during March and April, because its primary purpose was seasonal rather than continuous. There were occasions, however, when the patrol was also of aid in cases of emergency encountered by ships on the lakes. The base of the Great Lakes patrol was at Traverse City, Mich.

Activities of the permanently established Coast Guard Air Stations were roughly grouped in six categories—assistance flights or air sea rescue, patrol (including anti-submarine), law enforcement, training, test and administrative. Assistance flights, which constituted the traditional functions of the Coast Guard air arm, were undertaken for the relief of persons, vessels or aircraft in actual or impending danger. The variety of such flights was limited only by the different perils common to the sea. Sometimes direct aid was rendered the victims by the plane's own crew, if the judgment of the pilot led him to believe that a landing was feasible and the need immediate. In such cases, a pharmacist's mate, carried on the plane, was available to apply temporary medical aid, and the plane itself brought in the victim for hospitalization. More frequently, however, assistance flights were made in association with surface units, which were guided to the scene of the emergency by the plane. Vessels in distress, planes forced down at sea or survivors adrift in lifeboats or on life-rafts were objects of assistance flights.

Patrol flights were made for reconnaissance, convoy, coastal and offshore observation, and actual combat. Patrols were conducted not as a distinct Coast Guard function but as a part of the general operations of the several Sea Frontiers. Their missions as well as their achievements varied with the requirements of the whole war program.

The role of patrol planes in anti-submarine warfare was of decisive importance. Late in 1943, the Coast Guard's air fleet received Martin PBM-3, Mariners for patrol purposes.

The Coast Guard under war conditions was about 10 times its peacetime strength, with a huge training program in operation. Aviation personnel necessarily formed an important part of this program, and consequently many of the Coast Guard's aircraft were devoted to training activities. The training program, similar to that of the Army Air Forces and the Navy, was extensive, including familiarization, indoctrination, student flying, instrument flying, gunnery, bombing—as well as all such related fields as navigation and the engineering and mechanical training of ground crews. The Coast Guard air arm also carried on test and experimental work. In addition to the practical testing of planes, engines and equipment, experiments were conducted in the use of helicopters—a program carried out by the Coast Guard in cooperation with the Navy.

Administrative duties executed by Coast Guard aviation ranged from ferrying passengers to photographic flights. Aerial mapping



#### LOADING COAST GUARD DEPTH BOMB

Protecting convoys from lurking U-boats was one of the Coast Guard's main activities over the North Atlantic.

also was done, and Coast Guard aircraft cooperated with the U.S. Coast and Geodetic Survey in making aerial maps and in checking the accuracy of maps already in existence.

Two of the largest Coast Guard Air Stations, those at San Diego, Calif., and at Elizabeth City, N. C., operated extensive maintenance and repair centers, for major overhauls of Coast Guard aircraft.



#### OFFICERS OF CAP COASTAL PATROL

The Civil Air Patrol, organized by our private flyers, helped to patrol our coastal waters. They spotted more than 150 U-boats and sank some of them. Their warnings brought the combat planes of the Army, Navy and Coast Guard to the areas where the CAP had spotted lurking enemy submarines. The CAP also performed hundreds of other important wartime services.

## CHAPTER V

### THE CIVIL AIR PATROL

THE Civil Air Patrol proved to be a miracle of the war. Constituted as the world's largest aerial defense home guard, it had tens of thousands of patriotic members working without salary for victory. At the close of the year its planes had flown many millions of miles on patrol, courier and similar missions—24,000,000 miles in over-water operations alone—since its organization six days before Pearl Harbor. It had operating bases in more than 1,000 communities. Its work had been characterized by Robert A. Lovett, Assistant Secretary of War for Air, as "a job well done." All told, men, women and teen age boys wearing the CAP uniform numbered upward of 100,000. Officially the CAP became an auxiliary of the Army Air Forces, not as part of the Army but under the Army's direction. Shortly before the beginning of 1944, the organization was given a huge task and its greatest opportunity to help assure the future of American commercial aviation and build a bulwark of defense against possible enemy air attacks in the future. This was a mandate from the Army to enlist and give pre-flight training to boys in the 15, 16 and 17 year age groups. It guaranteed the Army Air Forces a vast reservoir of pilot material. For peacetime aviation it held possibilities of transcendent importance.

The CAP came into being for the twin purposes of implementing the national security and affording a means of permitting non-military pilots to continue to fly. In almost all the other nations at war civilian fliers were grounded for the duration. In the United States, Col. Earle L. Johnson, a Cleveland business man and a pilot for 14 years, grew alarmed at the unguarded state of airports and at the ease with which a saboteur might steal a plane and dump explosives on a war plant.

"It gave me the creeps," he said, "to think what a hundred determined Germans could do to a hundred power plants in one night, land their planes in a field, walk away and never be caught." The story is told that, as an experiment one night, he took off in his own plane and dropped a sand bag on a Cleveland factory.

That, and the determination of a majority of the nation's 100,000 civilian pilots to continue flying and be useful in the war effort, germinated the CAP. Its many millions of miles of over-water flying in small planes, most of them single-engine, in anti-submarine work in collaboration with the Army and the Navy, was only one of CAP's spectacular achievements. CAP flyers spotted more than 150 sub-



marines, and attacked many with bombs slung from emergency racks and aimed with bombsights made up of 20 cents worth of materials. When, in the Summer of 1943, the U-boat danger had passed, the CAP was relieved of its off-shore patrol duties. That type of flying, in which almost three dozen CAP pilots lost their lives and many airplanes were sacrificed, had been the organization's main contribution to the war effort.

Supplementing the anti-submarine work, however, was important courier, search and emergency delivery duty. In one instance the Baltimore squadron enabled an Ohio war plant to continue its work instead of shutting down to await the arrival of some essential parts. A 90-pound crate of the parts was flown in a CAP plane to the plant on the afternoon of the day that the emergency was announced. Courier services throughout the west for the Second Air Force alone ran on regular routes on schedules aggregating 20,000 miles of flying each day with a record of 97 per cent of trips completed during the summer months. Scores of lost airplane searches were flown successfully for the armed services. Forest patrols were flown in many States during the fire danger season. Whole Wings (State units) were called into action to save lives and property during floods. Many mercy missions were undertaken to deliver blood plasma and other medical aid.

Typical of the State Wings was that in Oklahoma. Early in 1944, it had 1,173 regular members, 175 provisional members and 623 cadets—pre-flight trainees. Of the total, 37 per cent were women. The Wing had local groups in 38 communities. There were many varied incidents in the daily routine of CAP flying. A filling station attendant in the wild country in the northwestern corner of Colorado heard a small plane buzz past his place of business. He walked out and on a fairly level strip of pasture found the plane at rest. Its owner, in uniform and wearing the distinctive red shoulder straps of the CAP, explained that he had been called out on a search mission. An Army plane was missing. Questioning developed that the flier was a Denver dentist who had taken this means of doing his very large bit for the war effort.

The end of the anti-submarine work, and the consequent necessity for the CAP to find a new major outlet for its tremendous and expert energies, was concurrent with other problems confronting the CAP official staff, headed by its commander, Colonel Johnson. Assisting him were Col. Harry H. Blee, operations officer, Major Kendall K. Hoyt, an engineer and writer, and others long identified with aviation. At first, a section of the Office of Civilian Defense, CAP had been on shaky legal ground when it did combat work. Its civilian planes had carried bombs. Increasingly its missions had become more military in character. Daily it had come into closer contact with the Army Air Forces.

That problem had been solved on April 29, 1942, when President Roosevelt signed an executive order transferring the organization to the War Department. The work went on without a change in policy or command, because its national officers already were AAF officers. The change merely meant that they reported to Gen. Henry H. Arnold, commanding the Army Air Forces, through channels, instead of to the director of the OCD.

A serious problem developed through a general limitations order issued by the War Production Board that froze all aircraft and placed heavy restrictions on their use. Many CAP units were stripped of their aircraft by requisitions made to perpetuate the War Training Service of the Civil Aeronautics Administration. That constituted the indoctrination of civilians in primary flight at Government expense. Nothing daunted, the CAP carried on. In the beginning it had been solely responsible for keeping open hundreds of airports which otherwise would have been closed as a wartime security measure. It had constructed many new fields and equipped them with hangars. It had posted airport guards and appointed clearance officers to check on all flights. Now it continued these same functions, meantime presenting its case to official Washington and the Army in hopes of alleviating the restrictions and handicaps under which it was forced to operate. Ultimately, two developments enabled the CAP to resume its activities in full. The WPB relaxed the terms of its general limitations order. The Army Air Forces began turning over to CAP units numbers of light aircraft.

In June, 1943, the Office of War Information published a highly laudatory report on the CAP, the first such recognition to be accorded



U. S. A. A. F. photo

#### CIVIL AIR PATROL CADETS

The Des Moines, Ia., CAP Cadets. After graduation from high school many entered the Army Air Forces for further training.

our civilian flyer's contribution to the war effort. Detailing some of the activities of the CAP squadrons, the report said:

"At a field in Virginia, CAP moved into a lonely area of sand and pines. The only buildings were a farmhouse and a poultry coop for 5,000 hens. To make room for landing strips, CAP personnel not only had to cut down trees but pay for them besides. To install two-way radios in CAP planes, the Virginia General Assembly appropriated \$5,400. Twenty North Carolina squadrons contributed approximately \$100 each to help the Carolina base get started. In the Middle West a group of mechanics raised money enough for one of their number to quit his job and serve on the coast for a couple of months. In Detroit the hat was passed, and when it had gone the rounds there was \$15,000 in it. Thereupon the Michigan Wing built a trailer kitchen and an operations office on wheels, serviced their planes and gathered a movable outfit complete with radio transmitter ready to roll at an hour's notice, all at their own expense.

"CAP mechanics worked night and day servicing the planes, knowing that engine failure meant a crash at sea for their comrades. Lacking gas pumps, they filled 75-gallon plane tanks by means of cans and chamois-covered funnels. Almost everything, including rubber boats, repair parts, radio equipment and money, was short at the hurriedly organized CAP landing fields.

"Pilots received \$8 a day, out of which they had to pay for their uniforms, food and lodging. That was for expenses, not as salary. CAP pilots were also to be paid depreciation on their hard-worked planes, and maintenance costs. The latter item they handed over to a pool for the common use of their base. None of them got rich under this arrangement, as Capt. Robert E. Thomas, of Baltimore, found out. A broker by trade, he figured that after flying 40,000 miles on a six months tour of active duty, he had \$56 left when all expenses had been paid. This made his earnings just a little under \$10 a month."

While the CAP pilots and ground crews had their expenses paid on active duty, many thousands of hours were spent by members on volunteer duty. On such duty no expenses could be entered in the ledger.

High on the list of CAP objectives was that of bringing industrial employees into more intimate touch with national security activities and indoctrinating them in the fundamentals of aviation. "It stands to reason," stated a CAP bulletin, "that a man or woman who pounds a rivet, or does some other job similar to those performed in other industries, will get an entirely new picture of the work if taught the fundamentals of aviation through CAP courses."

To that end Lt. Col. Johnson encouraged the establishment of what he termed "industrial squadrons." Interest grew in the project. CAP had considerable influence in improving the relations between

the employees and employers. In Georgia, 100 employees of the Bell Aircraft plant at Marietta were attending CAP classes, and several hundred more were planning to join them. The company supplied quarters for the meetings. In Michigan one squadron was composed entirely of civilian employees at the Romulus Army Air Field. Several Army officers volunteered to teach classes. Michigan's Technical Service Squadron in Detroit, formed to assure expert maintenance of CAP aircraft, was composed of plant artisans. The Michigan Wing also organized Women's Service Squadrons, most of whose members were drawn from industries, including employees of air lines, instrument companies and the U. S. Weather Bureau.

The CAP Cadet movement promised to provide a new generation of American airmen. Youth training in aviation, to bring the United States abreast of such nations as Russia, Germany and Japan, all of which had such programs before the war, was proposed by Thomas H. Beck, president of the Crowell-Collier Publishing Company in a letter to President Roosevelt in the Spring of 1941. The CAP itself had not yet come into being. The idea was sound. The war in Europe was proving that a reliable reservoir of young men schooled in the fundamentals of aviation was indispensable to the national defense. It was becoming evident that by the time a pilot reached the age of 25, his reflexes had slowed to such an extent that he had best leave combat duty to younger men. Statisticians figured that one-fifth of the flying crews of a nation at war would have to be replaced each year, not counting the normal losses in fighting.



#### THE CAP STARTS FOREST PATROL

Members of the New York Wing CAP, North Country Squadron, before starting patrol activities over the Adirondacks.



While any thought of regimenting our youth as it was regimented in Germany was foreign to American tradition, it was considered within the confines of democracy to offer pre-flight training to young volunteers. High school students could be introduced to the theory of flight, meteorology and navigation, and could be induced to enroll in mathematics courses necessary to becoming a member of an airplane crew. The idea fell on fertile ground, but the means of carrying it out except in a purely academic way was lacking until the CAP was formed. Then CAP deliberately postponed it until the organization had become thoroughly rooted and thus was able to undertake this new duty effectively. While the CAP was expanding and launching its flight work, Lt. Col. Johnson and Major Hoyt began working out the details of the Cadet program.

When the day arrived, the CAP launched its greatest project by a simple device. All squadrons were notified that they were authorized to form Cadet units to receive the same ground instruction as the senior members. For experimental purposes a limitation was imposed. Every male CAP member could sponsor only one boy Cadet, every female member one girl. That established a father-son and mother-daughter relationship between the seniors and juniors. Another limitation was imposed. Only young people in their last two years of high school could qualify as Cadets. That was based on the fact that other organizations had experienced trouble with "multi-level" instruction programs in aviation. The CAP would have a one-level program, one curriculum.

The response not only was instantaneous; it astounded CAP national headquarters. Reports began streaming in from every part of the country on the enlistment of Cadets. During the first nine months of the program, CAP pre-flighted 30,000 young persons. The total cost to the taxpayer was \$200. That covered the expense of issuing instruction sheets from CAP national headquarters.

"For the long pull," Lt. Col. Johnson advised all CAP units, "the most important aid we can give to recruiting will be the CAP Cadet program in which young men of 15 and 16 will be made ready for the armed forces mental and physical examinations at 17, and will continue their CAP training for another year, as members of the Air Corps Enlisted Reserve, before they are called to active duty at 18."

The formality of charging the CAP with the duty of procuring likely candidates for flight training for the air forces occurred when Lt. Col. Willis S. Fitch, in charge of the Aviation Cadet Branch of the Army Air Forces, asked Colonel Johnson to undertake the job. During the summer the services of CAP were indispensable. Schools were closed for vacation. Potential candidates for flight training were scattered. Normal recruiting channels were hard-pressed to deliver a given quota of young men in spite of a reduction in educa-

tional and physical standards. Up to then the CAP had permitted its Cadet program to progress without advertising. But now it employed newspapers, radio, exhibits and parades to publicize the fact that it had become an instrument for pre-flight training.

Typical of the enthusiasm among CAP seniors was that of a single member in Spring Valley, N. Y. He was the only CAP representative within miles. Regularly he reported to a squadron in Middletown, N. Y. When the Cadet program was established he organized 100 young men for training. He arranged with the local high school to use its shops and classrooms for instruction purposes.

Early in 1944, Colonel Johnson announced that an outline of courses for Cadets, covering 200 hours of instruction, would be issued. The courses were to be divided into four 50-hour stages requiring about three months each. Thus a Cadet who had only three months before his call to Army duty would receive all the pre-flight training possible. Those who remained longer in the CAP, as "Silver Wing Cadets," were to be given a wider range of subjects. Drill, physical training, Morse code and aircraft identification were stressed. In addition to those four subjects, the first 50 hours were to include CAP orientation, military courtesy and discipline, safeguarding military information, the articles of war, map reading, organization of the



THE CIVIL AIR PATROL  
Operations Office of the Maine CAP.

Army Air Forces, and a new course covering the time belts and the international date line. Cadets were advised to take first aid, because it was contemplated that those receiving a Red Cross certificate would not have to repeat the course in the Army.

Letters from young men who graduated to Army flight training came into CAP national headquarters by the hundreds. A typical letter read in part, "Only six short months ago, back at the (Army) pre-flight, where for two months we never saw an airplane, many cadets were struggling with navigation and weather, because the courses moved so fast. Those of us who had a preview through CAP had a comparatively easy time and got much more out of it."

Lt. Col. Johnson regarded the Cadet movement as important to the prosecution of the war and vital to the future of American aviation. It provided an agency assuring a reserve of pre-trained young men in peacetime to constitute a potential and readily trained air force for the national defense. Obviously, in evaluating such a program for peacetime, it must be borne in mind that combat flying is a young man's game. Under normal conditions the man trained for combat work would outlive his combat usefulness in five years. The continuing CAP Cadet Program would inspire a demand for training in the air services such as this country never had experienced.

Many believed, too, that the program could make a happy contribution to the solution of two pressing postwar problems, employment of men newly released from the air forces, and utilization of the manufacturing capacity of the aircraft industry. No conceivable development in commercial aviation of itself could be a solution to those two problems. The nation at the beginning of 1944, had only 170 airliners operating on domestic routes. If they were increased by 1,000 per cent in the year or two after the close of the war, CAP officials maintained, even that increase would not take up the slack in aviation employment and plant utilization brought about by peace. At best it would provide employment for only a few thousands among the millions to be released from the Services. All the airplanes required could be fabricated in a corner of one big war plant.

"Nearly everybody," stated Major Hoyt, explaining that his immediate concern was the war effort, "has been neglecting the importance of home town aviation. People have been thinking about big airplanes in terms of big aviation business instead of little airplanes as big aviation business. We had 25,000 private planes at the start of the war as compared with 350 airliners. If the ratio holds after the war, and if there is a 1,000 per cent increase in airliners, we will have a quarter of a million small planes. Instead of 100,000 private pilots, we will have a million. Instead of developing aviation at a few big air line terminals, we must develop it at thousands of little airports serving every community."

Lt. Col. Johnson suggested that cities now considering the con-

struction of war memorials in their public squares build, instead, memorial airports. Marshalling his arguments, he stated that the conventional memorial was, except for its sentimental and historical value, an unprofitable investment, whereas a city's investment in land for an airport was economically sound. If the airport project did not work out as planned, the land could be sold for other purposes. He recommended that communities provide flying fields as close to the center of town as possible. As soon as a field of 150 to 200 acres was graded and sodded, flying could start. Other improvements could follow.

"When peace comes, small airplanes will become available," Major Hoyt pointed out. "Local operators will buy them. They will hire instructors and mechanics. They will provide revenue with which the field can be cared for. If that occurs at thousands of fields throughout the country, a substantial contribution to the solution of an employment problem in aviation will have been made. A lot of young American lads have been recruited for the air forces, and their hope is that they will have a future in aviation. Every community that has sent these lads out owes it to them to make good on an implied promise. Presently any town without an airport will be in

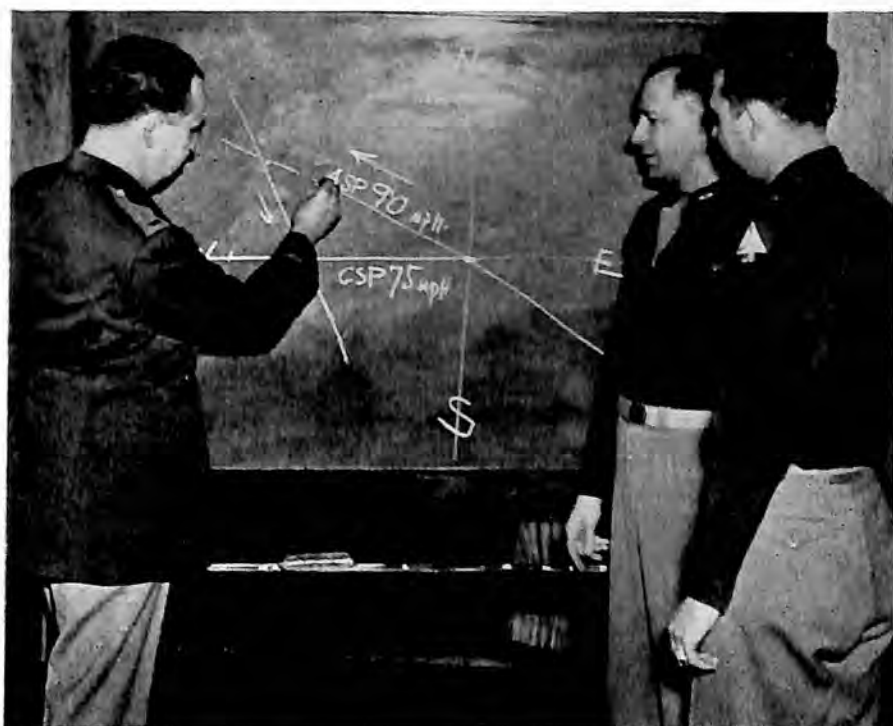

#### BIRMINGHAM, ALA., CAP

Lts. William Donovan, Harry Hoile and Aubrey Johnson preparing classroom instruction.



the same position as a town of 40 years ago without access to a railroad."

Quite apart from their duties in the war effort, members of the CAP were unexcelled in their enthusiasm for flying. They knew that the private pilot was a good customer of the commercial air lines. They saw an accelerated development of air line "feeder" routes and mail services resulting from the spread of the gospel of flying through the CAP Cadet program. CAP had brought to hundreds of communities an intimate acquaintance with aviation that never before existed.

During one month in Tennessee CAP officers gave the mental screening test to 1,575 boys applying for pre-flight instruction. Only a few of them previously had been closer to a plane than watching the machines in flight.

In a speech before the House, Congressman Hatton W. Summers, of Texas, said of the CAP, "My interest was aroused in this organization because of its demonstrated unselfish, self-reliant, willingness-to-do-something-about-it, fit-to-live-in-a-democracy sort of spirit, the sort of spirit which . . . makes free government possible."



#### THE NEW HAMPSHIRE CAP

Small parachutes were used to drop blankets, food, medicines and equipment in CAP rescue missions.

## CHAPTER VI

### AIR TRANSPORT IN THE WAR

THE reason that the Axis Powers had enough confidence to declare war on the United States was that they believed they could win it before we should be able to put enough men and supplies on the several fronts and maintain our armies in force long enough to finish a campaign. Neither the German nor the Jap expected our supply lanes to be kept open sufficiently to hold them back in any theater. That was to be their undoing. They knew less than they thought they did about logistics, that branch of military science which deals with the problems of bringing up armies and supplies to the points where they can be employed to advantage. Our supply lines were developed everywhere, on the land, on the sea and in the air. Our Navy kept open the sea lanes in cooperation with our Allies. American air transportation spanned all the continents and seas afflicted by global war. Thousands of personnel and thousands of tons of critical war supplies were in the air on our military routes every second of every day and night. This fast service brought every place in the United States within 60 hours of any battlefield. It helped speed the enemy into one inglorious defeat after another. In the United States, 85 per cent of all traffic on the civil air lines was military.

Eighteen domestic air lines and three international lines of the United States were playing highly strategic war roles on the home front and in the transport of personnel, equipment and supplies to fighting zones overseas, the Office of War Information reported, on the basis of information from the War and Navy Departments, Civil Aeronautics Board, Air Transport Association and the civil air lines. The following facts are from the OWI report:

According to Navy officials, retaking of the Aleutians in 1943 would have been postponed for months if air transport had not been able to fly in men and cargo quickly and in great quantity. Major Gen. Harold L. George, Commanding General of the Air Transport Command of the U. S. Army Air Forces, stated: "If it had not been for their (the air lines) wholehearted cooperation, it would have been nearly impossible for us to carry on the job in the way it has been done."

Although the operations of the Air Transport Command and Naval Air Transport Service with military and naval crews were expanding rapidly, the air lines, under contract with the War and Navy Departments continued to play a large part over the world military



U. S. A. A. F. photo

#### ARMY TRANSPORT IN NEW GUINEA

Natives stare curiously at one of our transport planes which has brought in men and supplies from Australia to the New Guinea battle front.

transport routes of the United States. The air lines activities fell in two main categories: (a) Transport operations, training programs, modification and maintenance of military equipment through contract to the War and Navy Departments. (b) Continued operation of commercial air transport, to a large extent given over to war services of various types.

On the whole, both military and commercial war activities were profitable to the air lines, several of which had been operating at a loss before Pearl Harbor. While figures on military contracts were restricted, the Civil Aeronautics Board stated that in the 12-month period ending August 31, 1943, the domestic air lines made a net profit of \$31,958,072, more than twice the total of the period, August 31, 1941-August 31, 1942.

Firms sharing in the war program were: Northeast Airlines, Mid-Continent Airlines, Eastern Airlines, Colonial Airlines, United Airlines, National Air Lines, Pennsylvania-Central Airlines Corporation, Western Airlines, Transcontinental & Western Air, Continental Airlines, Delta Airlines, Northwest Airlines, Chicago & Southern Airlines, Braniff Airways, Inland-Airlines, American Airlines, All-American Aviation, Hawaiian Airlines, Pan American Airway System, American Export Airlines, and Pan American-Grace Airways. ("Consairway," a subsidiary of Consolidated Aircraft Corporation, although not a commercial air line, engaged in foreign military transport activities parallel to those of the commercial lines.)

OWI pointed out that under contract to the armed services:

1—Commercial pilots and crews, in land planes provided by the Army and seaplanes by the Navy, were helping to operate the greatest fleet of world-girdling transport aircraft in existence—"the air line to anywhere." They engaged in cargo service, transport of high military and civilian officials, delivery of that greatest of all morale builders, mail, to armed forces overseas, and in a variety of special assignments.

2—Nearly half the prewar equipment of the commercial firms was sold or leased to the Army and Navy. More than a third of their experienced crews, and technical and administrative personnel was in the air services of the Army and Navy. These men, cooperating with technicians still remaining with the air lines, helped establish and operate land and seaplane bases all over the world, from New Caledonia and India to Alaska and Iceland.

3—The air lines assisted in training Army and Navy air transport navigators, pilots, mechanics, and meteorologists. In addition, pilots and maintenance men from the air lines were assigned as instructors to schools established and operated by the Army. Before our entry into the war, some R.A.F. and Chinese pilots and technicians were trained by the air lines.

4—Much military air equipment was regularly checked, repaired, or replaced in the shops of commercial air lines. Transient military aircraft also were serviced.

5—With military supervision, commercial air lines operated a number of modification centers where mass-produced Army and Navy transport planes, fighters, and bombers received last-minute changes or equipment required for special missions or theaters of war.

6—The air lines engaged in some research on and testing of aircraft and aviation devices and fuels. They helped develop life raft equipment and improved air cargo packaging.

Air lines engaged in international operations for the armed forces (in addition to training, maintenance and other services) were Pan American, American Export, Braniff, American, Eastern, Northeast, TWA, Northwest, United, Western, Panagra, Hawaiian, and Colonial. Domestic military cargo services within the continental United States also were operated by Eastern, Braniff, TWA, United, and American.

Within the United States, other domestic lines flew military cargo schedules for the ATC and participated in maintenance and modification activities. They were Continental, Chicago & Southern, Delta, Inland, All-American, Mid-Continent, National and Pennsylvania-Central.

OWI stated that in domestic operations: (1) The commercial air lines more than doubled their prewar volume of cargo—most of it vital war production equipment and supplies—through rearrangement



of schedules, elimination of non-essential stops, standardization and better utilization of equipment. This was done on not much more than half the original equipment. (2) They were carrying (in 1943) nearly twice as much air mail as in 1941. (3) The lines transported only about 25 per cent fewer passengers than in peacetime. Planes which once flew with half their seats empty were, under the priorities system, fully booked for each flight and for longer flights per passenger. (4) The commercial air lines accomplished that with a decrease in accidents despite a greater ratio of passenger fatalities. Because each plane carried a full complement of passengers, more per plane were killed in each fatal crash. During 1941, in 32 accidents in scheduled domestic operation, 44 persons were killed. The number of accidents declined in 1942 to 31, but fatalities totaled 71. Latest available Civil Aeronautics Board tabulations on scheduled domestic operations showed accidents through November 26, 1943, as 20, with 30 persons losing their lives.

Before Pearl Harbor, the domestic and international air lines of the United States were operating 434 planes. By May, 1942, 46 of them had been sold to the Government and 17 to other purchasers, including the United Nations. During May, 1942, the Army Air Forces bought 124 of the civil fleet, and leased an additional 34. About 100 planes went outright to the Army Air Forces and Naval Air Transport Service for operation by military crews. Seventy of the aircraft, after having been stripped of nonessentials, were turned back to their original owners to carry military traffic under contract to the War and Navy Departments. Many new planes for which the air lines had contracted were purchased by the Army for military use. In the Summer of 1943, the Army and Navy had begun to make available to the air lines for commercial services some of the planes earlier bought or leased. By December 3, the Army had returned 21 leased DC-3's and had resold five more to the air lines, while the Navy had returned three flying boats to Pan American. The air lines of the United States started 1944 with about half the size of their prewar fleet.

Contract operations were carried on by air lines personnel who wore ATC uniforms and in the case of NATS special insignia, but remained on the payrolls of their commercial employers. Some contract services were overseas, others within the United States. Cargo schedules were set and services directed by the ATC and the NATS.

Personnel of the air lines formed a reservoir of transport pilots, radio operators, dispatchers, flight superintendents, meteorologists, maintenance crews and others experienced in organization. Within six months after Pearl Harbor, at least a thousand skilled employees of the air lines had followed their planes into military service. Many of these men were killed in line of duty. Others received citations. Numbers of air line stewardesses volunteered as flying nurses. The

air lines no longer required applicants to be registered nurses. They could qualify with two years of college work.

Although the air lines sold or leased to the Government substantially half their equipment, they managed to continue their scheduled services at a high level. During the first six months of 1943, according to the Civil Aeronautics Board, 1,428,888 passengers were flown within the United States by the domestic lines, as compared with 1,567,608 for the first six months of 1941 and 1,875,268 for the same period of 1942. Totals for the entire years 1941 and 1942 were 3,817,718 and 3,121,185, respectively. Usually traveling on war business, passengers progressively averaged more miles per trip than in prewar days. Revenue passenger miles showed an increase from 589,204,195 in the first six months of 1941 to 723,214,782 in the same period of 1942 and to 735,341,450 in January-June, 1943.

Airborne cargo showed marked increases. Express flown by the domestic lines during the first six months of 1941 was 7,804,508 pounds, rising to 16,317,713 pounds in the comparative period of 1942 and to 28,803,546 pounds during January-June, 1943. Totals for the entire years 1941 and 1942 were 19,388,643 and 42,625,398 pounds respectively. More air mail was carried by the domestic lines during the first six months of 1943 than during all of 1941—50,504,847 pounds as against 43,279,838 pounds. For 1942 the total year's figure was 67,384,917 pounds of air mail.

Net revenue of the domestic lines, exclusive of cost-plus fixed fee Government contracts, was, according to CAB, \$8,229,321 in 1941, \$25,737,298 in 1942 and \$22,923,214 during January-August, 1943.

Several factors accounted for the seeming paradox of increased service from equipment diminished by almost half. 1—Commercial lines and cargo carriers averaged between 80 and 100 per cent use of their transport capacity on each flight. In 1942, the average was about 68 per cent. During 1941, it was not unusual for planes to carry only half their capacity loads. The doubled load factors in 1943 nearly made up for loss of half the equipment. 2—The lines retained only DC-3's and Lockheed Lodestar transports for their domestic operations. Maintenance, which previously had to take into account half a dozen different types of aircraft, could be concentrated on only two types. This made for greater speed and simplification in overhauling and in obtaining replacement parts. 3—Each plane was used more hours per day than formerly. In 1941, the average was 8½ hours per 24-hour day. Each transport plane in 1943 averaged between 10 and 12 hours of service daily. In 1941, air lines flew 1,100 miles per plane each day. The 1943 average was about 1,725. 4—A new wartime traffic pattern, eliminating some stops and curtailing schedules, was worked out so efficiently by the lines and the CAB that, despite the reduction in commercial flight equipment, only 28 per cent of prewar schedules were eliminated. 5—In January, 1942, the War Department estab-

lished a priorities system to give precedence to vital airborne cargo and personnel. Regional Air Priorities Control offices of the ATC were established throughout the country to issue the priorities. In case of equally important shipments or personnel contending for space on the same plane, the one with the greater distance to travel often was given preference.

As the war progressed, the lines handled new types of cargo which in peacetimes were too expensive to transport by air. In place of printed matter, films, electrotypes, flowers and style goods, the trend shifted to war tools and military equipment. Average weight of individual shipments increased from about eight pounds in 1941 to 15½ pounds in 1943. During the first months of the war blueprints and machine tools were shipped in quantities by air. Costly tie-ups in production were avoided by rushing materials or parts between factories which might be a continent apart.

"Buck Rogers stuff on a sound engineering basis," a veteran air transport pilot termed the world system of military transport routes flown by military, naval and contract air line crews. Our military air highways spanned the seven seas and reached into every continent to areas uncharted and unexplored a few years ago. The air lines, under the direction of the ATC and NATS, played a large part in this enormous air transport network.

Authorized by the Secretary of the Navy on December 12, 1941, the Naval Air Transport Service began operations in February, 1942. Less than two years later, the NATS was flying schedules over many important world routes. The NATS stated: "The Navy owes much to its contract air lines in having put into practice in the short space of two years a great deal that the lines had learned through years of experience. Internal operation and organization of NATS squadrons are modeled on Naval usage coupled with the best commercial practice. It is with reference to personnel, however, rather than to any other particular, that NATS is indebted to the air lines. An early call sent out to the air lines brought into the service a nucleus of highly trained and experienced air lines personnel. It is not unusual to see such officers conducting Naval air transport operations on the very locations where they once worked with commercial lines."

Pan American and American Export supplied planes and crews whose duties were much the same as those of the regular NATS. In helping service and supply our surface vessels and Naval shore installations, NATS and commercial contract seaplanes went anywhere the Fleet went. Air transport of medical supplies, special repair and replacement parts and technical personnel for the Fleet had no small part in the success of American operations in the South and Central Pacific.

The Collier Trophy, annual award for the outstanding achievement in American aviation, went in 1941 to the Army Air Forces and the

air lines of the United States for "pioneering world-wide air transportation vital to immediate defense and ultimate victory." Later, air transport facilities expanded tremendously, keeping pace with the campaigns of the United Nations.

Four principal world airways with innumerable branch and feeder lines were operated by the NATS and the ATC. One route spanned the North Atlantic, an operation which could be either nonstop or in several stages. A second route was by stages from the southern United States to Africa and across Africa to the Middle East, India and China. The third route, from Southern California by way of Hawaii, served military bases in the South Pacific. A fourth main route led from the Northwest United States to Alaska and the Aleutians.

The first contract overseas routes were pioneered by Pan American Airways for the delivery of lend-lease aircraft to the British and the return of ferry pilots. Early in 1942, several domestic air lines which always had operated exclusively in continental United States also contracted to fly transoceanic services. Pilots with a dozen years or more of inland flying experience were put through courses in celestial navigation, dead reckoning and radio code. As one pilot remarked: "There's no hocus pocus about flying oceans. Men have to be skilled and mechanics efficient, but flying is flying and navigation is navigation, whether it is over land, sea, mountains or deserts."

As in the case of all persons going overseas, personnel was im-



U. S. A. A. F. photo

#### ARMY AIR FORCES TRANSPORT OVER EGYPT

A military version of the famous Douglas DC-3 transport, C-47 Skytrain, hurdles the Pyramids.



munized against typhoid, tetanus, smallpox, cholera, yellow fever and typhus. Flight crew members were given practical instruction in aviation medicine, tropical medicine, first aid and survival. Periodically the courses were supplemented by bulletins on health problems likely to be encountered on the routes flown. A thorough physical examination was required of both flight and ground personnel before and after being based overseas.

The primary work of contract carriers was transportation of cargo, high-ranking military and civilian personnel between the United Nations, and mail for the armed forces overseas. Planes did not return empty from such assignments. They brought home cargoes of urgently needed war materials. Overseas shipments ranged from a 1,700-pound engine block, and all the parts to go with it, to tiny boxes each containing a queen bee and two worker bees for a friendly nation. Lend-lease, both to our allies and from them to us, shuttled across the world by air transport. Critical war materials went back and forth between American industrial centers and more than 50 foreign countries. At a South Pacific outpost, military construction was being pushed feverishly. Work came to a standstill when the crankcase of a Diesel power plant broke down. Nearest source for a replacement was a factory in Illinois. On a Wednesday afternoon, the 750-pound crankcase was loaded on an airliner and dispatched. On Friday afternoon, 7,000 miles distant, the part had been installed and the construction work resumed. Less than three days work had been lost.

Natural rubber was flown in from Brazil and Africa. One of the most important insecticides, rotenone, came to the United States by air from Brazil where it was derived from a jungle plant. Serums, anti-toxins, salves for burns, plasma and other medical supplies were flown to the battle fronts. Thousands of American wounded were returned to hospitals in this country aboard airliners.

In January, 1936, the commercial air lines formed the Air Transport Association. One of the main functions of the Association was to serve as a liaison agent between the lines and the military air services. At the outbreak of the war, the air lines through this organization were able to mobilize their personnel and equipment without delay.

When the Japanese fleet had been split after the Battle of Midway in June, 1942, one wing turning back under heavy American air blows, the other heading for Alaska, 10 air lines—Pan American, United, American, Northwest, Pennsylvania-Central, TWA, Chicago & Southern, Western, Braniff, and Panagra—flew planes into Alaska. They transported special troops and military equipment to Dutch Harbor. Air line pilots delivered Army bombers, with their crews and bombs. NATS flew personnel and material into Alaskan and Aleutian bases in squadrons of three planes each—the leader being a pilot familiar with the territory, the other two pilots flying in

the formation. Even as the Japanese were attacking Dutch Harbor, airliners were coming in at the airport with war materials. Full evaluation of the air lines contribution to the successful defense of Alaska, however, was to await the end of the war.

Alaskan operations remained one of the most difficult and graphic of the air lines war activities. When the hospital at Nome burned, a replacement, complete from 24 beds and X-ray equipment to hypodermic needles and rubber gloves, was loaded on two Northwest airliners and flown in. Within two days after burning, the hospital was being rebuilt. A sawmill needed in the Alaskan wilderness, at a spot miles from a road, was dispatched by air. For the Alaskan Highway 1,200-gallon gasoline trucks were cut in three parts, shipped by air, and welded together at their destination. Similarly, power units, gasoline storage tanks—some of 25,000-gallon capacity—road graders and other heavy highway equipment were flown where needed.

Crews flying the Alaskan runs had to be seasoned. In the first months of the war, Alaskan flying was mostly through snowstorms, over uncharted wilderness and mountains, without adequate weather reports or other navigation aids. At times, the weather was so cold that oil congealed into a thick gum which had to be cut with gasoline. On one hop, with a plane load of passengers, the pilots were alarmed by strange vibrations that shook the ship periodically. They finally discovered the source; the passengers were stamping their feet to keep warm.

"You just draw a line on a map and then take off and go there," the transport pilots said. In reality, it was not that simple. Gasoline needs, cargo weight, resistance of prevailing winds, and a dozen other factors were calculated carefully and a course charted accordingly before a transport plane took off for far places. But this complex procedure was so thoroughly developed and flight officers became so experienced that it amounted practically to "drawing a line and then going there."

The world system of U. S. military airways had passed the pioneer stage in 1943. Transport pilots no longer ran risks of being unable to land in the Far North because some stubborn bull moose had taken a stand in the middle of the runway and refused to budge. Remote coral atolls and jungle rivers had become seaplane bases. Large airfields and adequate installations were strung through jungles where, a matter of months before, trail-blazers from the Army Air Forces and Pan American were dicker with natives to clear runways, using molasses-flavored twists of chewing tobacco as inducement. Our military airways made any spot on the globe less than 60 hours flying time from any airport in the United States.

Safety was the keynote in the evolution of the maze of overseas airways developed by the ATC and NATS. Fighting craft had to be expendable; transport planes were not. They were valueless unless

they could get their valuable cargoes through to the points of need.

The air lines and the Services worked out many new safety devices for flight operations and vastly improved existing ones. Most of these were still on the secret list but it could be said that their application to postwar aviation would bring about revolutionary changes. Not only was every precaution taken to assure safe operation of transport planes: careful provision was made for the crews in case of crash landings in wild and remote places. Great progress had been made in the development of emergency equipment. No transocean plane left an airport without full equipment for survival at sea in case of accident. Self-inflating life rafts and life belts, concentrated foods, medicines and fishing tackle enough to take care of the entire crew for extended periods of time accompanied each flight. Similar provision was made for Arctic and tropical runs.

Subsequent to the spring of 1942, the armed services furnished some of the air lines with new large transport planes for contract operations. At the same time, demand on equipment which the lines were regularly operating became progressively heavier. Without a greatly increased supply of pilots, navigators, radio operators, flight engineers and mechanics, our military and civil needs could not be met. An Airline War Training Institute was formed on August 12, 1942, to fit civilian recruits for either civil or military air transport. As it developed, the Institute engaged in no actual training work. It evolved into an agency for supervising training programs for military personnel undertaken by the individual lines. Previously some of the lines had engaged in training activities for Army personnel. Results had been uneven, chiefly because of lack of standardized curricula. Later the program was changed to provide for standardization and coordination of transitional training of military personnel. The Airlines War Training Institute prepared training courses and assured an even flow of trainees. By February, 1943, the program was working smoothly. While only the larger lines were equipped to give the full series of courses, the following participated in the training of Army or Navy personnel: All-American, American, Braniff, Chicago & Southern, Colonial, Continental, Delta, Eastern, Inland, Mid-Continent, National, Northeast, Northwest, Pan American, Panagra, Pennsylvania-Central, TWA, United and Western Air.

Instruction included: 1—Transitional training of Army and Navy fliers who had finished basic flight courses at military bases. Previously familiar only with single-engine, low-horsepower training planes, these men were bridged over to powerful, multi-engine transport craft under supervision of seasoned transport pilots. Emphasis was on instrument flying and radio navigation. As the Army fliers advanced, they were assigned to regular cargo runs as co-pilots for training under flight conditions. 2—Transition training of Army and Navy navigators, radio operators and mechanics. Trainees received

on-the-job instruction in operation and maintenance of multi-motored transport craft. In addition, some civilian enrollees received primary and advanced training as pilots, mechanics, radio operators and meteorologists. 3—Training for pilots and crews of transoceanic runs included instruction in special problems of navigation, techniques for making "in-flight" repairs, intensive drill in "ditching"—the art of abandoning a plane at sea—and in handling life-raft equipment.

The navigation school of one air line fitted out flying boats as "flying classrooms," complete with chart tables, drift meters and all instruments required for a 50-hour flight. Graduates of this instruction helped plot the course for the first raid on Japan, led by Major General James H. Doolittle. Another school gave overseas pilots, some of them men who served with the AVG in China, 250 hours of technical instruction—a course equivalent to a year at an engineering school. Flight training for the ATC by the air lines, nearly at an end early in 1944, played a large part in the training of military crews for transport operations of the ATC.

Not only was ATC and NATS equipment flown under contract by the air lines checked and overhauled by the commercial firms; they also handled some of the equipment used directly by the two military transport services. Several of the lines had contracts with the War Department for overhauling and repairing engines and instruments of training craft. After 500 or 600 flying hours, the engines of a training plane received a thorough overhaul. This consisted of taking the engine completely apart, cleaning it, inspecting for wear and defects, replacing defective parts, putting the engine together again and



#### THE LOCKHEED CONSTELLATION

Designed and built for TWA service, this four-engine, long-range and fast airliner went into U. S. Army Air Forces transport service. It was powered by Wright Cyclones.



testing it completely. The work was done under the direct supervision of military and air lines maintenance officials.

One of the most spectacular of the air lines war contributions was special work done at some of the Army and Navy modification centers. These centers were not manufacturing plants. They were way stations between factory and front where planes could be fitted with whatever additional equipment might be needed for any specific task. Any standard plane could be tailored for a variety of operations under totally dissimilar weather and tactical conditions. At an air line modification center, pontoons were put on Army C-47's—military versions of the DC-3. Wheels on the pontoons were retractable, enabling the plane to land on snow, water, ice or land. Big bombers purchased by the British and Russians required certain changes. The work was done by air lines modification centers. Most types of our own aircraft had at one time or another been modified to meet developments in enemy aviation. Planes originally intended for the special tasks of one branch of the services often were modified for use by another. Obsolete models were altered for such work as towing targets for aerial gunnery and anti-aircraft practice. Planes were modified by Delta Airlines for use as "dusters" which sprayed chemicals deadly to insects over infested jungles and swamps where our troops had to live and fight.

Cargo planes were changed overnight into flying hospitals. With special equipment installed, others became meteorological laboratories on wings, able to go anywhere for advanced weather information. A majority of the aircraft used in the Aleutians, the South Pacific and the Far East were modification jobs, as were those of the Tokyo raiders and the Floesti raiders. One big bomber model required several hundred separate changes before it was ready for action. Most changes, however, were not so wholesale. When necessary alterations accumulated on a particular type of plane, the basic design was modified at the factory.

At the beginning of the war none of the air lines had adequate facilities for the rush of modification work required at once by the armed services. Planes were staked out in the open; and day and night in wind, sleet and sub-zero cold, the mechanics swarmed over them. Thousands of additional men and women had to be found and trained. Beauty shop operators, barbers, soda fountain boys, school teachers and milkmen were recruited and given intensive courses of instruction. The manager of one center in the heart of the western cattle country had to post notices urging new employees to remove their spurs before getting to work.

Early in 1944, modification centers were housed in modern plants, one costing more than \$12,000,000. Continental Airlines huge center for B-17 Flying Fortress modification was an example. Company officials stated: "The concrete apron upon which the modification cen-

ter stands covers an area embracing 16 city blocks. Airplane parking space totalling 3,800,000 square feet and auto parking totalling 200,000 square feet are provided. Matching the 90 acres of concrete in size are the two huge hangars at the north end, where Flying Fortresses will receive the latest improvements before being flown away to dispersal points, there to receive their crews who will take the ships directly into battle. The hangars are 600 feet long and more than 400 feet wide, with an inside height of 35 feet—large enough to house all present installations at the airport, with room to spare. Other construction includes two-story concrete buildings on the two sides and in the centers of the hangars to provide office space, tool rooms and various shops: an 800-man cafeteria, a headquarters building and a power and heating plant. Although the number of Flying Fortresses modified at the new center is a military secret, it can be said that production has increased sevenfold over Continental's former output."

Experimental and research work of the commercial lines was of incalculable benefit to the ATC and the NATS. During peace years, the commercial lines developed most of the planes that became the backbone of our military transport operations. The Douglas DC-3, standard airliner, was converted to the C-47, work horse of the Army Air Forces. The Curtiss-Wright Commando, developed for, but never used in, commercial services, became the C-46, and the Douglas DC-4, 40-passenger transport which was on order for the lines before the war, became the Army's C-54. The Lockheed C-69, converted from the Constellation, was conceived and developed for commercial use.

Important improvements were made on aircraft tires, wheels, propellers, instruments, accessories and operations technique. Tests were being made constantly on pressurized cabins and superchargers for high altitude work, lighter fabrics and other structural material, packaging and safety equipment.

The need for airborne cargoes to be rushed throughout the world made packaging of prime importance. In the past, the Army and Navy insisted first of all that materials be packed stoutly to prevent damage from rough handling. Often the packing case, made of inch-thick, reinforced pine boards, was heavier than its contents. The NATS and the ATC, with the cooperation of the lines, developed much less bulky packaging. Strong, specially processed cardboard and fibreboard were substituted for wood and metal wherever possible. Heavy wrapping paper and burlap also were used in place of weightier materials. For example, the NATS stated that pay load of one type of seaplane had on occasion been increased from 4,000 to 6,000 pounds by reducing the tare weight of cargo carried. A shipment of airplane engines which, under the old methods, would have weighed 26,625 pounds and required the entire space of five or six transports, was reduced by the NATS to 8,862 pounds and shipped complete in one plane. New types of gadgets to secure cargo aboard planes not only added to the

safety of operation and reduction of damaged cargo, but helped materially in making possible the use of lighter packaging material. Research in the field of light, tough packaging turned each of our cargo carriers into the equivalent of several craft. Implications for postwar airborne commerce were enormous.

In cooperation with the ATC and NATS, Pan American, American and Transcontinental & Western developed self-inflating life rafts with complete equipment—standard in the Army and Navy air services. The rafts were equipped with either of two perfected devices for obtaining drinking water from the sea—one a small still and the other a chemical device.

The maintenance department of Northwest Airlines, plagued by losses of costly washers, screws, bolts, and other small parts dropped by the mechanics, made an experiment with 12 blind workers. Their patience and ultra-sensitive fingers recovered and correctly sorted 99 per cent of the lost parts. Savings were estimated to be thousands of dollars monthly. Typical example of ingenuity applied to a problem in aviation mechanics was a hoist for the huge wheels of bombers, invented by Luther Mead, of American Airlines. Formerly, changing two of the 580-pound tires was a 24-hour job for a crew of six men. The Mead hoist cut the time to one hour, the crew to two men. Another device, developed by Transcontinental & Western air, tested in the shop hydraulic landing gear which previously had to be tested by the actual process of take-off and landing. This saved countless manhours and eliminated accidents resulting from flight tests with faulty gear.

Engineering departments of the lines kept precise performance charts on all the military aircraft they operated. Every time a wing fluttered, a carburetor mixed too lean, or instruments varied a fraction from accuracy, that fact was entered on a master chart which itemized all parts of the plane. Through these charts covering months of operation, aircraft manufacturers checked the strength and efficiency of any component of a plane in ratio to the performance of the whole. Thus guided, and working toward a functional balance, manufacturers could redesign or replace unsatisfactory parts.

The commercial air lines shared the credit for development of the 100-plus octane aviation gasolines which add such power and range to our aircraft. Even before the war, the lines were conducting exhaustive tests on the then new superfuels under conditions of extreme heat, cold and altitude. Their findings were invaluable in the production of high octane gasolines and even more potent aviation fuels which were in the laboratory stage early in 1944.

Participating to a varying extent in all the above activities were Pan American, American Export, United, Continental, American, Northwest, Pennsylvania-Central, TWA, Eastern, Delta, Braniff, Chicago & Southern and Western.

In the course of transoceanic runs, commercial air lines helped the Navy spot submarines and survivors of torpedoed ships. One commercial pilot took his plane down to investigate a small iceberg lying directly in a convoy route. The iceberg began shooting at the plane. The enemy made numerous attempts to trick transport planes off their courses by sending them fake radio bearings. During thick weather over the North Atlantic it would be relatively easy for a pilot, flying on false information, to overshoot his goal and land on some German field across the Channel. Fortunately, a thorough system of checking radio reports prevented loss of our planes, although there were some close calls.

Eastern Airlines, a contract carrier that operated on regular schedule through a region of violent tropical thunderstorms, served as a flying weather bureau for the combat craft which also used the route. The line rearranged its schedules so that its aircraft could depart every morning well ahead of the military flights, and radio back weather information at short intervals. NATS scheduled flights from Seattle to Alaska and Aleutian bases performed this same function for combat aircraft in that area.

A comprehensive description of our Army Air Forces air transport operations was given by Gen. Henry H. Arnold in his report on January 1, 1944, as follows:

"In May, 1941, plans were developed for expediting the movement of aircraft from the factories to the points at which the British would fly them overseas. When the Japs attacked Pearl Harbor we received pleas from all parts of the world for personnel, planes, engines, parts and supplies. We strove to meet these requests. Ships of the sea were slow and subject to attack by submarine. The war would be lost if we used only such means of transportation. Airplanes are weapons of war that can not be held on the ground; there, they are a liability rather than an asset. We must get them in the air and keep them there. That requires supplies and replacements in constant streams. Thus came into being the Air Corps Ferrying Command: at first across the Pacific—then the South Atlantic—then the North Atlantic and now to all corners of the world where we take aircraft, important personnel, mail, supplies of all kinds—to places they are needed most. Starting with only two officers and one clerk in a small room, today's Air Transport Command totals over 85,000 officers and men.

"Mounting aircraft production soon created a difficult situation for this new unit. Ever increasing numbers of aircraft were leaving the factories to be delivered to American and British combat units. This meant increased flying, the requirements going up steadily day by day. The first ferried plane was delivered to the British on June 7, 1941. By December 7, 1941, approximately 1,200 had been flown to the British and our own Air Forces, and the first delivery had been



made across the South Atlantic to Egypt. From that time to this the number of planes in the air and the volume of freight carried have steadily increased. On one recent day 680,000 pounds of materiel, munitions, and supplies were delivered by air to one theater of operations. This information will be of neither aid nor comfort to our enemies.

"The Air Transport Command's shuttle service to Britain and the Middle East and its exploratory flights to various parts of the world paved the way for routes which were needed when the United States entered the war. Arrangements for the development of such important bases as Christmas Island, New Caledonia and bases in Greenland were completed. A string of weather stations was laid out in the far North and the beginnings of a communications network developed, without which our world-wide flying might not have been possible. After Pearl Harbor, domestic ferrying increased and has continued to do so. To this was added the urgent need for delivery of all types of aircraft overseas and the air transportation of strategic cargoes, including mail and personnel.

"In addition to ferrying planes and routing flights to deliver supplies, special flights and deliveries were carried out wherever needed. Two dramatic examples of this are the delivery, on short notice, of the Flying Fortresses which were the Army's striking power in the decisive Battle of Midway and the sending of a number of C-47 transports, loaded with bombs and ammunition, to the Aleutians at the time of the attack on Dutch Harbor. Both of these actions influenced greatly the course of the war.

"By July, 1942, it had been determined that military air transportation had grown up; the Ferrying Command was reorganized as the Air Transport Command, to perform all kinds of air ferrying and air transportation. Under its control the various airlines, on contract with the War Department and flying aircraft issued to them by the Army, render transport services for the armed forces and our allies. This contract system is worthy of special mention. While taking care of our domestic air transportation requirements, we look out in so far as possible for the American public's air travel needs. Of course neither civilians—nor the fighting forces—obtain all the service they wish they could obtain. Four thousand additional transport planes could be used today if we had them.

"The current offensive of the Eighth Air Force against Germany, the role of air power in our attack in Italy, and the air offensives of the U.S.S.R., to pick three examples, depend upon the steady movement of new combat planes both to augment the air forces and to replace those planes shot down, damaged, or laid up from ordinary wear and tear. This means a steady movement of planes in such numbers as even two years ago would have seemed the product of a fevered imagination.

"To help meet the tremendous need for personnel, women pilots were first employed by the Ferrying Division of the Air Transport Command in September, 1942. At the same time a training program was begun to train women pilots for ferrying and other duties. Now known as the Women's Airforce Service Pilots or WASPS, they are doing an effective job of delivering aircraft in the United States, from the smallest planes to P-47 Thunderbolt fighters, B-17 Flying Fortress bombers and C-47 Skytrain transports. By January 1st, 1944, about one thousand women, including trainees, will be on duty. Not all qualified applicants can be accepted for training, since the Army Air Forces cannot train or utilize women pilots at the expense of training and experience needed for men pilots in the theaters of war.

"The WASP helps fill the need for professional non-combat service. For example, the Training Command uses many women pilots to ferry airplanes to and from certain bases for major repairs or overhaul. However, in recent months the WASP has assumed additional duties



THE DOUGLAS C-54 SKYMASTER

The size of this huge four-engine Army transport is shown by that of the men around it.

—towing targets in gunnery schools, acting as co-pilots on night searchlight missions, and the like. Women pilots are also flying some of the weather planes which take meteorologists aloft. Indeed, this organization has come to serve a variety of useful purposes in the Army Air Force organization.

“Since the Ferrying Command was established in May, 1941, the transport and ferry systems of the Air Transport Command now extend over some 110,000 miles of routes. In recent months an average of more than twelve million miles a month have been flown in ferrying operations and more than ten million in air transport.

“A word of caution must be said about this impressive growth. Figures of miles flown and tons delivered by air are impressive. However, when the total supply requirement of an army in the field or of a sizeable air force are considered, they dwindle. A mission of 300 four-engine bombers drops more than a thousand tons of bombs. To this cargo must be added tons of gasoline, ammunition, and oil. After the mission, there are engines to be replaced, spare parts provided. Air bases must be kept supplied with machinery, tools and men. Flying and ground personnel must be fed, clothed, housed, doctored, and they must have mail—by the ton. It will be realized that air transportation itself does not solve the whole problem of supply, but the ability to fly in vital cargo on short notice can turn and has turned the tide of battle.

“Members of the Women’s Army Corps are now serving 20,000 strong at airfields and air bases in the United States. WACS are filling two hundred different jobs in the Army Air Forces, such as Link trainer operators, parachute riggers, cryptographers, camouflage technicians, weather observers, and flight control tower operators. One Air WAC, an expert watch repairer in civilian life, is now a bombsight repairer. Another, a dog fancier, has a key position in the dog training program of one of the domestic Air Forces. The great majority of Air WACS are filling less unusual, but equally essential clerical, communications, and motor transport jobs. The Army Air Forces need over 100,000 additional WACS to serve on domestic airfields and thousands more overseas. The WACS serving our air stations are carrying on with the efficiency and effectiveness exhibited by the men whom they replaced. Thus we are saving man power.

“The Air Service Command, formed in October, 1941, surpasses in size and is doing a wholesale round-the-globe business greater than any mercantile establishment in the world. It employs 300,000 civilians, of whom 43 per cent are women. Incidentally, many of these loyal workers were previously considered unemployable, but the Air Service Command has found suitable tasks for the handicapped, for the blind—and even midgets find their size an asset when working inside the fuselages and wing sections of certain planes. The Air

Service Command's 300 warehouses contain 500,000 different items, five times as many as are listed in the Sears Roebuck Catalog. Every one of them is needed for the 150 aircraft types of the Army Air Forces. The storage space in the United States alone is equivalent to a building 75 feet wide and 100 miles long.

"The Air Service Command prepares equipment and supplies—which are moved by ship to 210 foreign ports. It can now be stated that for every pilot overseas, the Air Service Command sends out the surprising average of nine tons of aviation supplies monthly, not including food and other items handled by the Quartermaster.

"Because of the technical knowledge with which aircraft equipment must be handled, the Air Service Command retains control over maintenance of all equipment. In the course of one month, thousands of airplanes at home and abroad require major repairs which the crews of the combat units on the spot cannot make. These planes are repaired and overhauled by the Air Service Command Depots. Some inkling of the extent of ASC operations may be gathered by the fact that within the United States alone, the Air Service Command supplies 4,000,000 barrels of aviation gasoline a month. One barrel would last the average motorist a long time.

"The Air Service Command finds answers to a host of war emergencies every twenty-four hours. For instance, two boat loads of Air Forces supplies were on their way to China and Burma. Weeks had been spent assembling the cargoes, and the freighters crept through submarine infested waters for two months. Within one day of their destination, both were torpedoed and sunk. ASC Headquarters, however, had a list of every item aboard. In eleven days a replacement supply had been brought together from all parts of the nation, loaded aboard other ships, and the journey began again. The theater commander received word that his lost supplies had been replaced before he learned his original shipment had been sunk. On July 15, 1943, the engineering officer of the Twelfth Air Force was in Sicily to determine at which place on the island our battle-scarred airplanes could receive much-needed overhauling. Personnel, equipment and spares were urgently needed for this great air offensive. The officer left Africa on July 16 and arrived at Patterson Field, Ohio, Headquarters of the Air Service Command, on July 19. Two days later the supplies had been accumulated. On July 22, the officer took off in a four-motored plane, which was loaded to capacity with trained men, and landed in Africa on July 23. Planes bringing everything else he needed followed within a few hours. He had been gone exactly one week."

General Arnold described the incredible efficiency with which wounded soldiers were being evacuated by air transport: "Since Pearl Harbor, over 125,000 casualties (sick, wounded and injured) have been flown from combat zones in American transport planes.



This simple statement encompasses one of the greatest accomplishments of modern aviation medicine, an accomplishment of interest to every parent of a soldier in any branch of the Army. The first obstacle that had to be surmounted in developing the air evacuation service was the supposed danger of killing the patient, estimated by some medical authorities to be a real one in the case of head, chest, spine and internal injuries. Yet the safety of transporting wounded by air has been demonstrated beyond doubt. In the Mediterranean theater from the beginning of the Tunisian campaign in November, 1942, to the close of the Sicilian campaign in September, 1943, more than 25,000 men with all types of illnesses and wounds were transported 8,000,000 miles by air. Only one patient died—one in 25,000.

"The second obstacle was the shortage of air transports. Airplanes, it was said, could not be spared solely for such purposes. This obstacle was surmounted by the simple conversion of cargo planes carrying troops and supplies to the front to the transportation of patients on the return trip to the rear. Air evacuation is a boon to the morale of ground troops, and aids the theater commander by quick removal from the battle zone of his non-effectives. Trips which would take weeks by hospital train or ship are now flown in a day. Air evacuation is an outstanding example of successful cooperation among Army Air, Ground and Service Forces.

"Much of the progress of the air medical program is due to the excellent care given the injured, sick and wounded men by our nearly 7,000 nurses. Included in this group are the flight nurses, who have received special training for their work at the School of Air Evacuation, Bowman Field, Ky. Today, long flights are commonplace. One soldier with a broken back was brought to Walter Reed Hospital in Washington, D. C., from Kunming, China, via India, and Miami, Florida—nearly 15,000 miles in 82 hours. Trips which would take weeks by a hospital ship or train with a staff of doctors and nurses are now flown by transport planes, staffed by a flight nurse and non-commissioned medical technician, in a day or two.

"Flight nurses are carefully selected and trained in phases of aerial medicine, intravenous therapy, tropical medicine, field sanitation, compass, map and aerial photography orientation, what to do in case of air and gas attacks, and other matters. The lives of the men may depend upon her proficiency. Besides looking after the comfort and needs of the sick and wounded men, the nurse can also be helpful in maintaining high morale. Each patient requires individual attention. The nurses of the Army Air Forces have met the tests of battle in a manner to merit unqualified approval.

"Complete hospital service now moves with the mobility of war itself. Six days after the Army hospital in Nome, Alaska, burned down, a new and complete 25-bed hospital had been flown in from a distance of 3,400 miles. Two field hospitals were flown over the Owen

Stanley Mountains in New Guinea. In Sicily, a 50-bed hospital was moved by air a distance of 44 miles in two and a half hours from the time it was dismantled until the time it began receiving patients at the new site."

The Pan American Airways System had two kinds of operations: 1—Special missions and services performed for the military to all the world battlefronts. 2—Services over the civil air routes it pioneered, routes on which the nation depended for movement of international priority passengers, mail and express between 46 countries and colonies, including the British Isles and neutral Portugal, the Belgian Congo, Hawaii, Alaska and a network of some 50,000 miles in the Caribbean area, Central and South America. In each category, the miles flown, and passengers and cargo carried in 1943 had far exceeded 1942 totals. And the services operated by Pan American crews for the Army and Navy outstripped the total plane miles flown by Pan American on all its civil routes not only during 1942 but during the last year of peace. Statistics for the system tell the story.

In 1943, Pan American's aircraft flew a total of 65,346,000 miles as compared with 43,939,744 in 1942 and 24,875,491 in 1941. Passengers carried were nearly double the 1941 figures, 606,700 as against 391,013; passenger miles stood at 475,470,000 as compared with 228,630,621. In 1943 the system carried 49,345,000 pounds of cargo, more than doubling the 1941 figure of 20,339,255. The mail load of 14,465,400 pounds was more than four times the 3,489,619 pounds carried in 1941. Ton miles flown totaled 72,735,000 compared with 29,779,429 in 1941. Including special and chartered routes, Pan American Airways flew 96,355 route miles during 1943, as compared with 95,786 in the last year of peace.

Special wartime missions performed by Pan American during 1943 were many and varied. One emergency cargo flight took a Boeing-built Clipper completely around the world, and marked the first aerial crossing in history over the Indian Ocean direct to Australia. This included one flight of 3,460 statute miles non-stop. Pan American flew President Roosevelt to and from Africa early in the year for the historic Casablanca conference, carried other heads of government and high military and diplomatic officials on many wartime missions which required the utmost in speed and security. The military services operated by Pan American with military transport aircraft covered routes assigned by the Air Transport Command and the Naval Air Transport Service in accordance with shifting requirements of world strategy. One Pan American division alone, set up to perform services assigned by the ATC, flew 1,250,000 miles a month, carrying overseas cargo at the rate of 3,500,000 ton-miles every 30 days. This division had 117 flight crews, of which 76 were expert in four-engine aircraft operations.

On November 17, 1943, Pan American flight crews had com-

pleted 5,000 actual over-ocean crossings since the Jap raid on Pearl Harbor. That figure included 3,259 flights across the North and South Atlantic, 1,741 over the Pacific between the United States mainland and Hawaii and on the long run to the South Pacific theater of war. During the remaining days of November and the month of December, 588 additional over-ocean crossings were completed, making a total of 5,588 since Pearl Harbor. In Alaska, Pan American operated for the NATS out over the fogbound Aleutians, and piled up new records in service between principal population centers of the Territory and the United States to speed defenses and help oust the Japanese from footholds on Attu, Agattu and Kiska.

In China, Pan American's affiliate, China National Aviation Corporation helped the ATC to maintain China's aerial supply line to the outside world over the Himalayas to India.

Between the Americas, Pan American and its affiliates stepped up services by introducing night lighting facilities, by all cargo flights, by greater utilization of aircraft, by construction of new terminal facilities to speed maintenance and cut turn-around time, and by opening a new international air gateway at New Orleans.

At the beginning of 1944, plans were completed for consolidation into one operating setup all the System's Latin American services. Under the name of the Latin American Division, and with headquarters at Miami, Fla., this unit was designed to administer the 50,000 miles of air routes previously under the jurisdiction of the Eastern Division at Miami and the Western Division at Brownsville, Tex.

With the entire system participating in the war effort, postwar plans for Pan American were receiving close attention as well. Pan American long before Pearl Harbor had launched a program for the construction of 50 giant Clippers, each capable of carrying 153 passengers from New York to London in 10 hours at a fare of \$100. On other Pan American routes, at comparably low fares, the Clippers would provide 24-hour service to Australia or China and 22-hour service to Buenos Aires.

On October 26, 1943, Juan T. Trippe, president of Pan American, made a speech in which he envisioned an air age in the postwar world which would make the entire globe one neighborhood. To enable the United States to meet on an equal basis the great foreign air transport monopolies in the competition for a fair share of future world trade, he recommended one strong American international air line, a community company, owned and controlled not by any one aviation interest but by all American transportation interests able to contribute, under an organization plan approved by the Government. He believed it imperative that the Government formulate a national policy for international air transport solely on the basis of "what is best for our country as a whole."

Organized in the latter part of 1942 to carry out operations for

the ATC, one Pan American division served over 15,570 foreign route miles with ATC aircraft to 70 different locations in 31 countries and colonies on three continents. Its operations in 1943 were nearly five times those of 1942. Its total miles flown were approximately one-third of the total logged by the entire Pan American World Airways System in 1942, while cargo ton and passenger miles represented about half the total carried by the company. It completed more than nine times as many Atlantic crossings as Pan American had piled up in scheduled flights prior to Pearl Harbor. It operated the largest fleet of aircraft in the entire system. Its personnel increased 451 per cent, 78 per cent from within the system. To carry out this operation for the ATC the division naturally drew heavily on the experience, personnel and know how of the five regular operational units within Pan American—the Atlantic, Transpacific, Eastern, Western and Alaska Divisions—and system-affiliated companies.

With its fleet of great four-engine Clippers reduced by one-half, Pan American's Atlantic Division nevertheless was able with four aircraft to maintain an operations and traffic record as brilliant as that performed the year before with eight. On both commercial runs and special assignments for the Government services during 1943, the



#### AMERICAN AIR TRANSPORT IN ASIA

A variety of cargo is being unloaded from a Curtiss C-46 Commando on arrival at its China terminal from India. All supplies for the U. S. Fourteenth Air Force in China had to be flown in after the Japanese capture of the Burma road. Commandos carried overloads over the Himalayas on almost every trip.



Clippers logged more than 2,276,000 miles over airways which link the United States with Europe, Africa and South America. The year's 430 transatlantic crossings brought the total since the service was pioneered in May, 1939, to 1,700. The division recorded 40,703,994 passenger miles and 38,916,244 ton miles of cargo flying in 1943. Cargo shipments included blood plasma, medicines and surgical dressings; films, foodstuffs, construction materials for overseas bases; rubber, mica, industrial stones; 416 tons of mail. One cargo item was 22 feet long and weighed 2,750 pounds.

In addition to its special missions for the military and its regular commercial services, that Pan American division also operated a fleet of Navy flying boats for the NATS. For personnel of the NATS also, it maintained a flight mechanics school from which, since the first graduation in May, 1943, 365 men had been assigned to squadrons and Fleet duty. The training program embraced theory and practice, with classroom lectures supplemented by work in Pan American shops and training on equipment being groomed for flight. On March 31, Pan American opened, at its Atlantic Division's New York marine terminal hangar additions which more than doubled the available floor space. Steel for the new structures was recovered from Port Washington, L. I., site of the company's first transatlantic base. The Division's personnel numbered about 3,100.

Pan American's Transpacific Division in 1943 carried out a calendar year of operations for the Navy, which in an incredibly short time, had turned from defensive action to a large scale offensive throughout that vast Pacific's war theater. The division, which had seen one Clipper destroyed at its dock in Hong Kong and another riddled by machine gun bullets on Wake as war flamed across the Pacific, suffered only two minor casualties in 1943. At one island station a Quonset hut was demolished by bombs and a crash boat received 147 holes from shrapnel. Transpacific completed 1,559 schedules, piling up totals of 6,200,000 plane miles, 13,836,270 cargo ton miles and 43,300,000 passenger miles.

Transpacific operations comprised service between the United States mainland and the Hawaiian Islands under a certificate of public convenience and necessity, and service beyond the islands to the South Pacific theaters of war for the Navy. At the end of 1943 Pan American had made a total of 2,042 Pacific crossings since Pearl Harbor. Many important military and Government authorities were carried. A new twin hangar was constructed by the Navy on Treasure Island in San Francisco Bay, Transpacific's U. S. base, and put in service by the Division during the year. Division personnel perfected new re-coopering methods to conserve weight and space of cargo by which the equivalent of nine Clipper loads was saved during the month of June, 1943, alone.

It was out on the Pacific too that the Navy and Pan American

wrought another air transport miracle. A Navy plane operated by a Pan American flight crew under Capt. J. H. Hamilton was forced down on the 20-foot swells for engine repairs several hundred miles from shore. For 42 hours the aircraft rode the heavy seas while two other Navy planes brought duplicate parts for repair and made the transfer. The technique they worked out for take-offs and landings under these conditions laid the groundwork for other achievements in Pacific air transport.

In the American Far North, Pan American's Alaska Division operations were coordinated to shorten lines of communications, speed men and supplies to war posts and obtain greater utilization of planes for the service of our forces combatting Japanese invaders in the Aleutians. Air transport was of invaluable aid to the military because of the geographic and climatic extremes of the Territory, its sparse, scattered population, dependence on the States for men and material, including food, and difficulty and slowness of supply by surface transport. Having pioneered in the Territory since 1932, bringing organized air transport to the principal population centers and airway connections with the States at Seattle, Pan American was able to make substantial contributions.

July, 1943, was the climactic month in the Battle of the Aleutians. One small segment of it, Pan American's operations during that month as compared with the same period a year previous, affords an idea of the tremendous scope of air transport as a whole on the Alaskan front. During the month Pan American completed 334



PAN AMERICAN AIRWAYS CLIPPER

One of the Boeing 314 flying boats in Pan American service.

schedules as compared with 128 in July, 1942. flew 477,440 plane miles as compared with 88,190; 3,131,236 passenger miles as compared with 384,456; 81,657 cargo ton miles as compared with 4,113. Indicative also of the increased tempo of air operations in Alaska generally was the fact that while for the first calendar year of the war, Pan American alone carried 8,107 passengers and 195,842 pounds of express, in 1943 it carried 20,204 passengers and 2,778,972 pounds of express, flying a total of 4,262,478 plane miles and 24,233,125 passenger miles. Personnel increased from 796 to about 1,400. The largest single cargo item carried was a 3,220-pound PT boat engine flown North during the Aleutians campaign.

Pan American's maintenance and engineering department continued to pioneer improvements in winterizing equipment and technique to effect greater utilization of aircraft. Through the initiative of the Division Meteorologist, Carol Beamer, a combined meteorological briefing office was formed at Seattle to pool the manpower of various agencies for the good of all serving the Territory. Intensive training courses were conducted in maintenance, meteorology, flight training, communications and traffic.

After a year of air evacuation of refugees from Hong Kong and from the debacle in Burma in 1942, China National Aviation Corporation (CNAC), the air line in which the Chinese National Government and the Pan American World Airways System had been partners since 1933, could settle down in 1943 to a year of unprecedented air transport over the world's worst airway in efforts to maintain China's last supply line. Initial successes of the Japs in the Pacific area after Pearl Harbor had lopped off China's contact with the outside world at the Crown Colony, then the alternate routes by air to Burmese ports. CNAC and the ATC commenced flying war supplies over the hump of the Himalayas—between China and India—into blockaded China and returning with essential raw materials for the United Nations war machine.

With considerable new equipment, and personnel expanded nearly 200 per cent—many of its pilots former fighters for Gen. Chennault's famed Flying Tigers—CNAC's plane miles and cargo ton miles flown during 1943 were more than 100 per cent above 1942 totals. One CNAC senior pilot, Capt. Harold Chinn, had a record of nearly 400 flights across the hump. Another, Capt. Moon Chin, made survey flights across a section of the mountains even more forbidding to assure an alternate aerial lifeline in the event that reverses should make the present route unserviceable.

Extending southward from the international air gateway at Miami, Fla., over seven different routes to Mexico, the West Indies, the Caribbean area, the north coast of South America and down its east coast to Buenos Aires in Argentina, Pan American's Eastern Division fleet flew 12,146,294 plane miles in 1943, more than double the mile-

age of the last pre-war year and 35 per cent above the total for 1942. More than 125,000 passengers—an all-time high in air travel between the Americas—were flown 128,818,699 passenger miles, a 26 per cent increase over 1942. The 5,581,823 pounds of air express carried by the Division was 61 per cent above the previous year's record. As in 1942, both passenger and cargo transport were for the most part on Government priority.

More schedules were added to points strategic in hemispheric defense and essential to a speedup of transportation of personnel and supplies in the war effort. Passenger fare reductions averaging 10 per cent went into effect on most routes of the Division. Factors which

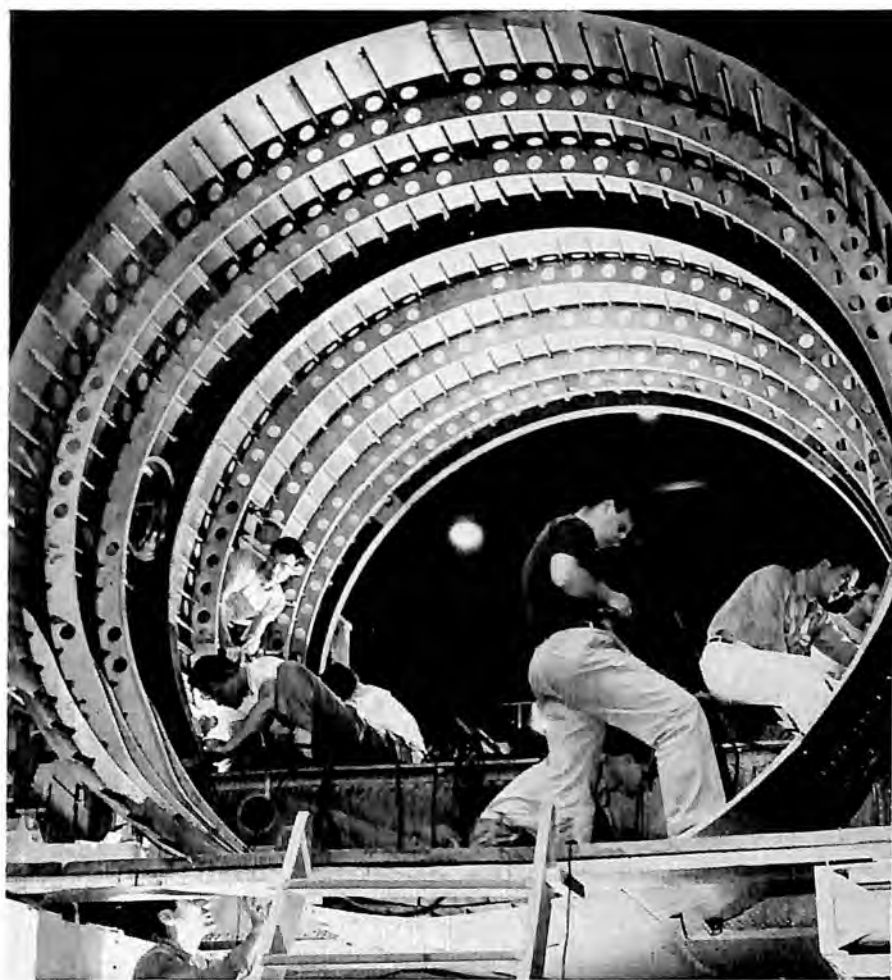

#### BUILDING THE LOCKHEED CONSTELLATION

Employees at work on a barrel section of the giant transport before attaching it to other similar sections to form the long fuselage. Each section was spherical because the cabin was pressurized for substratosphere flying.



figured in the speedup were innovations in maintenance and operations practices to increase loads: the start of night flying in Brazil by Pan American's national affiliate, Panair do Brasil, and on the route from Miami to San Juan, Puerto Rico; an all-freight Clipper service across the Caribbean begun late in 1943; and completion of a vast new maintenance and office building on Pan American Field in Miami, the largest and most costly structure in the Pan American World Airways System. It provided hangar facilities for servicing from 12 to 18 Clippers at one time.

Personnel on the Eastern Division gained to a total of 4,200 in 1943—30 per cent of them women. Breaking a tradition of all-male flight crews on the system, the Eastern Division prepared to use stewardesses on two of its international routes as a result of increased wartime services and the manpower problem.

Charter service operated for the Rubber Development Corporation was expanded in 1943, and several changes in routes were made to speed transportation of supplies to the raw rubber producing areas in the Amazon Valley. At the request of the U. S. Farm Security Administration, the Division flew nearly 200 laborers from the Bahamas to help harvest spring crops.

The opening of a new international air gateway at New Orleans to serve the Latin American area was a highlight of Western Division operations in 1943. On June 13, a Boeing-built Stratoclipper, four-engine, high altitude transport took off from New Orleans airport on new service to the Canal Zone over a route bisecting the Gulf of Mexico to Merida on Yucatan and thence down the Central American republics to Guatemala City in Guatemala, Managua in Nicaragua and Balboa. Flying the 2,000-mile route in 12 hours, the new service brought every city of the vast Mississippi Valley within 24 hours of the vital Canal Zone. Through domestic air transport in the United States and the networks of Pan American and Pan American-Grace Airways southward, brought air transport service to 57,000,000 residents of the 19 States in the Mississippi and Ohio River valleys and provided direct links with 200 cities in Central and South America.

Over its trunkline service to the south from its home base at Brownsville, Tex., the Western Division stepped up air transport to accommodate ever increasing wartime demands, while Pan American's Mexican affiliate, Compania Mexicana de Aviacion (CMA) shattered air transport records in the neighboring republic. CMA on February 16, started the first night flying route in the Western Hemisphere to be financed by an individual company. The lighted airway en route from our border to Mexico City cost nearly half a million dollars and was constructed of Mexican materials wherever possible. The division set new records in 1943. It carried more than 90,000 passengers some 68,000,000 passenger miles as compared with 74,193 passengers, 54,093,060 passenger miles in 1942. Plane miles flown

were estimated at 5,400,000 as against 4,214,532 miles during 1942.

The chief weapons with which Pan American-Grace Airways clipped the wings of Axis-controlled air lines on the west coast of South America before Pearl Harbor were faster, more efficient air transport through increased frequencies, faster schedules and new routes to duplicate the Axis service. With the Axis definitely out of the picture in 1943, Panagra continued to speed air transport operations to meet the increased demands of a hemisphere at war; and in 1943 it outstripped the 1942 record. Plane miles reached 4,600,000 as against 4,030,000. The number of passengers jumped to 69,000 from 56,770, while passenger miles flown were 57,500,000 as compared with 43,000,000. Two million pounds of express were carried as compared with 1,330,000. Panagra carried 280,000 pounds of mail in 1943 as against 242,000 pounds in 1942. Personnel rose from 1,600 to 2,500. In February, 1943, Panagra extended to Buenos Aires the all-cargo route started in 1942 from Balboa in the Canal Zone to Lima, Peru, making the 5,400-mile run the world's longest all-cargo commercial air transport operation. In Ecuador, Aerovias del Ecuador-Panagra extended operations north from Quito to Ipiales in Colombia. Three new Douglas DC-3s permitted Panagra to increase its trans-Bolivian and Lima, Peru-Santiago, Chile services and to operate extra cargo flights of importance in stimulating the economic life among the eight great republics that it served.

American Airlines in 1943, with many of its trained personnel in the armed forces and with only about 60 per cent of its prewar fleet of Flagships left in commercial service, rolled up an impressive record on its domestic commercial routes and made an outstanding direct contribution to the war effort in its work for the Air Transport Command both at home and abroad. American Airlines carried on its commercial schedules 26,163,969 pounds of mail in 1943, compared with 14,634,679 in 1942. It flew 16,234,099,319 mail-pound miles compared with 9,092,367,649 in 1942. Express also rose to peak heights with 20,976,790 pounds carried in 1943, compared with 11,971,155 in 1942. Much of this cargo, though carried on scheduled commercial flights, was vital war material. Typical were the first transcontinental all-cargo flights started on August 20, 1943, when shipments on the east-bound plane were headed to four continents and 18 war production cities throughout the country. Though the company was unable to accommodate thousands of passengers who wanted to fly, Flagships left in commercial service flew 26,039,898 revenue passenger miles in 1943, compared with 27,645,067 in 1942. The company transported its six millionth passenger in October, 1943.

American Airlines overseas operations proved to the world that a well-trained pilot and crew could fly to any corner of the globe at a few hours' notice. Training schools for navigators, pilots, radio officers and flight engineers were established by the company, and the



#### THE CURTISS C-46 COMMANDO TRANSPORT

The Curtiss C-46 Commando was used extensively on the India-China wing of the Air Transport Command, hauling supplies to the Fourteenth Air Force in China. It also was used in many other parts of the world.

men who were to fly the big Consolidated C-87 Liberator transports and Douglas C-54 Skymasters which American Airlines was to operate for the Air Transport Command were ready to take on the job as soon as the planes were available. With crews which had never flown outside the Western Hemisphere before, American established routine operations across both the North and South Atlantic and on to India. Besides routine flights across the North and South Atlantic, American Airlines undertook special assignments almost overnight. Such was the survey flight from Newfoundland direct to Marrakech, North Africa, in April, 1943. The crew of five were awarded the Air Medal.

American Airlines also flew the first Douglas four-engine C-54 ever to cross the Pacific from New York, through San Francisco to New Guinea, with vital aircraft parts for General Kenny's hard-pressed air forces in that battle theater. To keep American Airlines planes flying on overseas schedules, bases were established from Greenland to India, and mechanics performed miracles of maintenance against heartbreaking odds, servicing planes from the Arctic at temperatures of 70 degrees below zero to the tropics, where intolerable heat and monsoon rains combined with pestilence and disease to make any activity almost unbearable. Up to December 30, 1943, American Airlines had chalked up approximately 1,200 transatlantic flights for the ATC in less than 15 months and was currently operating approximately 150 a month. During its India assignment, American Airlines

carried almost five million pounds of cargo into beleaguered China and at the height of these operations, was making six round trips a day between India and China. All overseas crews were drilled in ditching procedures—the correct procedures for emergency landings on water and in the handling of life-raft equipment. The procedures worked out by American Airlines were adopted as standard by the Air Transport Command. Besides foreign flight operations for the Air Transport Command, American Airlines also operated cargo ships on regular schedule on the Army's domestic routes.

During the company's operations under contract to the Air Transport Command, American Airlines crews flew to every continent in the world, to 27 countries outside North America, and to 90 cities outside the United States, including nine points in Alaska and nine in Canada scattered from one coast to the other. On the domestic routes which the company was flying for the Air Transport Command, it operated into 26 cities in the United States not on its regular commercial schedules.

Training of personnel, modification of Army planes, experimental work on radio, fuels and equipment, and planning for the future were among other activities. Besides training flight crews to man the ships which the company was operating for the Air Transport Command, hundreds of Army ground mechanics were given a three months on-the-job training in transport technique, working three shifts a day. In cooperation with Edo Aircraft Corporation, the engineering department worked out the engineering details involved in putting the first floats on a Douglas C-47, the Army version of the DC-3. The company also cooperated with General Electric in testing various types of aircraft equipment such as superchargers, armament control, navigational and flight control instruments and special type armament. Firing tests on this armament required the use of water targets and tow targets. American Airlines manufactured the former, and the company's pilots, engineers, draftsmen, stenographers, data transcribers, shop foremen and mechanics aided General Electric personnel in the work. One plane, a B-23, a Douglas-built medium bomber, was redesigned for high-altitude flying. This necessitated the installation of modified engines, the design and fabrication of new engine cowling, pressurization of the forward cabin and redesign of miscellaneous items. The engineering department also handled Consolidated B-24 modifications to British standards at the request of the U. S. Government, and a group of C-46 (Curtiss Commando) modifications for U. S. military cargo service. A Douglas C-54 was converted into a litter ship for the transport of wounded.

Recognition came to many American Airlines personnel for outstanding service during 1943. First prize for original research in flight operations given by the Air Transport Association went to Dixon Speas, assistant to the vice president of engineering, for his

Flight Plan Analyser and Altitude Selector. Second prize went to Robert Ehrke, meteorologist. Luther Mead's device for changing huge airplane tires received wide acclaim for the economy it has made possible in time and labor. A test stand for radio transmitter tubes won an award.

Braniff Airways in 1943 flew 66,520,573 passenger miles, and opened a new route from Amarillo north to Pueblo, Colorado Springs and Denver, adding 371 route miles and linking Texas and Oklahoma with Colorado. South of San Antonio, an additional 150 miles were opened to Laredo, adding a second international gateway, supplementing the existing international service through Brownsville. Another route was granted to Braniff, from Houston to Austin, 154 miles, which was to bring the system to the new total of 3,309 miles. Authority to serve the Tri-Cities of Moline, Rock Island and Davenport was granted, and service was to begin in February, 1944.

In addition to the many special war missions the company was called upon to perform, regular cargo runs between Dallas and Panama, as well as a route between Dayton, Ohio, and Sacramento, Calif., by way of Dallas, were in service. The company continued its many training programs for army personnel. Army pilots, graduates of the Air Training Command, were given a course in the multi-engine transition school operated for the Air Transport Command at Brownsville. Other members of the air crew received extensive training at the Braniff radio school and the school for mechanics at Dallas. The Dallas shops of the company did double duty for the Services as well as regular maintenance of the company. The increased efficiency of the maintenance department and the experiments of the Braniff laboratories contributed much to the effectiveness of the company's part in the war effort. Personnel increased from 802 employees in 1942 to more than 1,200 in 1943.

Continental Air Lines on January 1, 1944, had a staff of 2,500 persons, about 40 per cent of them women. Continental's war jobs, which included the operation of a modification center for B-17 Flying Fortresses, were largely responsible for the tremendous increase in personnel. The company also operated a domestic cargo division for the Air Transport Command, and had supervision over several training schools required to produce skilled personnel for these activities. The new modification plant at Denver was set on a concrete apron 90 acres in area, covering 16 city blocks. It provided a parking area of 3,800,000 feet for airplanes, and 200,000 square feet for auto parking. Two huge hangars, each approximately 600 feet by 400 feet in dimensions, formed the heart of the new center. Double production lines were provided in each.

In connection with the modification work, Continental tested the bombers before they were turned over to the Army Air Forces for delivery to dispersal points. This activity, along with the ATC



operations, resulted in a great increase in pilot personnel. In addition to the regular daily operations for the ATC, Continental completed several special missions for the Army Air Forces. Continental's route mileage reached a total of 2,615 miles.

Delta Air Lines carried on during 1943 seven varied war assignments, in addition to its normal air line operations. Delta's 1943 war contracts, some of which were completed in the latter part of the year, included modification of Army bombers to fit them specifically for service abroad; operation of air cargo routes for the Army Air Transport Command, hauling freight between Army bases in ships flown and maintained by Delta personnel, with Army students as co-pilots; training Army officer pilots in instrument or blind flying procedure and in other phases of advanced big ship flying; training Army enlisted mechanics in air line maintenance; overhauling aircraft instruments for Army aircraft; overhauling and reconditioning hundreds of engines removed from Army planes; and dusting low areas with poison, by airplane, to prevent mosquitoes and malaria in the vicinity of military camps.

Delta's air mail and air express more than doubled in 1943 compared with 1942. Mail pound miles totalled 1,355,881,897 for 1943, an increase of 152.2 per cent over the 1942 total of 537,594,140. Air express increased 104.9 per cent, with a total of 230,928,859, pound miles for 1943, compared with 112,667,778 pound miles in 1942. Delta flew 43,500,567 revenue passenger miles in 1943, an increase of 30.4 per cent over 33,357,957 in 1942. The system load factor averaged 88.76 per cent in 1943, an increase of 24.1 per cent over the load factor in 1942, which was 71.5 per cent. The number of passengers carried in 1943 mounted 11.4 per cent over 1942, from 106,336 to



BEECHCRAFT C-43 TRAVELER

Army Air Forces personnel and light cargo transport used at our air bases at home and behind the battle lines abroad.

118,463. The average passenger haul in 1943 was 366 miles, a 16.19 per cent gain over 1942 when the figure was 315 miles.

Eastern Air Lines in 1943 continued its record performance for the Air Transport Command, flying special cargoes and equipment, supplying essential servicing or repair jobs for Army and Navy planes, and assisting in training military personnel. Despite a 21 per cent revenue-mile decrease due to Army contracts which put its Silverliners into war paint, Eastern Air Lines maintained a high performance with its regular passenger, mail and air cargo service. Commercial operations continued with only a 3½ per cent drop in revenue passenger miles. Express pounds increased 27 per cent, while mail loading was up 50 per cent. So successful was Eastern's pioneer all-cargo flight, originated in June, 1942, when no other air line regularly scheduled non-passenger air mail and cargo trips, that in January, 1944, Eastern found it necessary to schedule a second all-cargo flight between New York and Miami.

Northwest Airlines had a personnel increase of more than 800 per cent in 1943. Most important of Northwest Airlines war activities was the operation of transport and cargo routes into the Northern Region for the Alaskan Wing of the Air Transport Command. Northwest's previous long experience in operating through similar climatic conditions was a valuable adjunct to the ATC in this respect. For the purpose of maintaining a high quality of flight personnel for this and other operations, Northwest established and maintained flight training schools at Billings, Montana; Rochester, Minnesota, and Minneapolis.

Requiring by far the greatest number of employees, however, was the operation of Northwest's bomber modification project at the newly completed Riverside hangars at Holman airport, St. Paul, Minn. Here the complete modification of many bombers a day was carried out, fully equipping them for service in many types of combat areas. With personnel adequately trained at the St. Paul hangars, Northwest operated a second bomber modification project at Vandalia, O., near Wright field. Research was carried on in cooperation with the Army Air Forces in an effort to overcome the icing problems presented by flights in the North. Other research projects included work with the Minneapolis Honeywell Regulator company in connection with flight tests of instruments manufactured by that company and also a static precipitation research project.

Northwest carried a total of 5,001,481 pounds of air mail in 1943, a gain of 1,888,297 mail pounds over 1942. In 1943, Northwest carried 93,394 revenue passengers a total of 63,787,683 revenue passenger miles. That was an increase of nearly 12,000,000 revenue passenger miles over 1942 and an increase of 2,791 revenue passengers.

Transcontinental and Western Air had an Intercontinental Division. Its pilots, operating under the Air Transport Command, flew

military personnel and equipment millions of miles to foreign fronts, making more than 1,100 transatlantic crossings in the first 20 months of war. The TWA modification center turned out a heavy parade of B-25 Mitchell bombers, ready for action against the Axis. The TWA training schools sent to the Army hundreds of pilots, navigators, radio operators and aerial engineers.

One of the TWA vice-presidents, Otis Bryan, served as personal pilot to President Roosevelt on his flight to Casablanca and also on his later journey to Cairo and Teheran for United Nations conferences.

The first Lockheed Constellation, forerunner of the postwar luxury skyliners, was completed for TWA and promptly turned over to the Army Air Forces for military use.

On the civilian non-military front, TWA executives had post-war plans, and had applied for more than 100 new domestic and foreign route stops, which would add more than 13,000 miles to present routes.



#### FOR BELOW ZERO FLIGHT OPERATIONS

It was 35 below zero the day this picture was taken at the Minneapolis airport, but the Northwest Airlines crews in charge of maintenance and overhaul of the Curtiss Army C-46 Commandos remained on the job. While mechanics and other experts were at work in the special nose hangar, other crews worked inside the ship which was heated by motor-driven units. The wings and tail were covered with heavy canvas.



United Air Lines photo

#### FLYING FREIGHT CARS

Interior of one of United Air Lines Cargoliners put in coast-to-coast service in 1943. Passenger seats of a Douglas DC-3 were replaced by cargo bins.

United Air Lines in 1943 flew more passengers, mail and express than ever before in its history, despite reduced equipment resulting from the release of airplanes to the Government for military operations. At the same time, United operated Air Transport Command routes within this country, to U. S. possessions and across the Pacific. As still other highlights of United's war-aid program, the company modified large numbers of four-engine bombers for combat duty and engaged in the extensive training of both flight and ground personnel for the armed services.

In regularly scheduled operations over its coast-to-coast and Pacific Coast system, United registered gains of approximately 23 per cent in revenue passenger miles flown, 61½ per cent in mail ton-miles and 7 per cent in express ton-miles as compared with 1942. Abnormal wartime conditions accounted for United's record of 357,000,000 revenue passenger miles, 11,030,000 mail ton-miles and 3,941,000 express ton-miles during 1943. These figures compared with 1942 totals of 290,273,780 revenue passenger miles, 6,827,977 mail ton-miles and 3,679,393 express ton-miles. Revenue airplane miles for 1943 were 21,900,000 as against 22,100,203 in 1942.

Flying under contract for the Air Transport Command and with

ATC planes. United in 1943 flew approximately 800 transpacific flights and 2,400 other flights in this hemisphere. Without prior experience in overseas operations, United crews began flying four-engine Air Transport Command planes across the Pacific in September, 1942, at the same time beginning operations for the ATC within this country and to its possessions. These services continued at full pace during 1943. United flew a total of 11,533,612 miles with men, materials and mail on its domestic and overseas routes in 1943. Loads were in excess of 30 million pounds. Cargoes included about everything—food, medical supplies, parachutes, life-rafts, aircraft parts, ammunition, armament, aviation fuel and automotive equipment. In numerous cases, United crews flew into combat areas to deliver vitally needed materials and supplies directly to isolated military units.

The Air Transport Command routes over which United conducted military operations aggregated approximately 16,000 miles in length or about two and a third times the mileage of United's regularly scheduled domestic services. During 1943, United moved to extend its passenger-mail-express services to numerous cities in areas adjacent or tributary to its transcontinental and Pacific Coast system.

In 1943, United reduced passenger rates by approximately 10 per



United Air Lines photo

#### FOOD FOR FLYING TRAVELERS

United Air Lines served more than a million meals aloft in 1943, prepared in one of its eight commissary kitchens such as that shown here.



cent, to an average of 5.1 cents a mile, and lowered air express rates by approximately 12 per cent. At the same time, the company accepted substantially lower payments from the Post Office Department for the transportation of air mail. In 1943 also, United started service into Washington, D. C., thereby directly linking the national capital with other points along its system; resumed service between Los Angeles and San Diego which had been temporarily discontinued due to war conditions; added Eugene, Oregon, as a stop on its Pacific Coast system, and started a new coast-to-coast Cargoliner service.



U. S. A. A. F. photo

#### FOR BOMBING PRACTICE AT NIGHT

Preparing Beech AT-11 Kansan trainers for night bomb training flight.

## CHAPTER VII

### AVIATION TRAINING FOR WAR

THE vast war aviation training programs were so eminently successful that at no time was adequate personnel lacking for the many different branches of our rapidly expanding American air power. By 1944, the training programs had reached their peak. Millions of young men, and women too, had entered some form of aviation service by the hundreds of thousands. They were waging war in countless different ways wherever American flying equipment was in use in every theater of the war. The training program of the Army Air Forces was one of the greatest undertakings in history because of the huge number of air crews and ground personnel required. The Navy's aviation training program, while not as large, was equally important, of course. Others which made the air operations possible were the training programs of the Civil Aeronautics Administration, the civil flying and mechanics schools, the aircraft manufacturers and the air transport companies, as well as the various kinds of aviation in the colleges and public schools.

Gen. Henry H. Arnold gave a comprehensive description of the success of the Army Air Forces training program in his report of January 1, 1944, as follows:

"The overall program of the Army Air Forces was designed on the basis of a plan to give us overwhelming air superiority over our enemies in the shortest possible time. There was no question as to whether the training program could be carried out; the Army Air Forces had to become the largest single educational organization in existence in a very short time. Facilities were secured, teachers were hired, and textbooks were written while the first classes were being held. At the start there was little training equipment, such as bomb-sights, navigators' sextants or drift meters. Worst of all, actual planes were lacking. Instructors were somewhat in the position of a man teaching another to swim by showing him a glass of water, but we improvised until teaching materials were ready, working with mock-ups and synthetic aids.

"Nearly 500 hotels, plus garages, theaters, warehouses, exhibition halls, parking lots, athletic fields and other structures were leased. There was no time to build such facilities; to do so would have strained the nation's manpower, transportation system and stock pile of materials. Leasing also prevented large outlays of money. The cost of permanent construction is over \$1,000 per man, as compared with an annual overall housing cost of \$119 per man in leased facilities.

“Experienced Army Air Forces officers were perilously few in number. We had to spread them through the growing organization. When the Allied nations began sending their cadets to the United States for training, additional duties were put on the shoulders of the experienced men. At one time foreign cadet training required a substantial part of our training equipment and personnel. About one-third of all our facilities were used for this purpose. In the United States were trained thousands of young men from Great Britain, the Netherlands East Indies, China, the Central and South American countries and others.

“Our entire training program had to be coordinated so that the air and ground crew members of the Army Air Forces would complete their individual training and form combat teams when the planes were ready. Our training system could be compared with assembly line production. Individual training produced skilled specialists, such as the mechanic or bombardier, and the specialists were assembled along the line into fighting teams. Further along, they were assembled into still more complex combat teams; for instance, the reconnaissance units had to become thoroughly familiar with ground force operations; troop-carrier units had to practice with the ground units they carried into battle. At no place in this assembly line was progress easy, not even at the earliest stages. As a cadet who had just arrived at a basic flying school remarked: ‘The cockpit of a basic trainer looks like the Grand Canyon full of alarm clocks.’

“The Army Air Forces built new airfields, and trained men on them at the same time. It was not unusual to find a training field with dozens of planes flying above it, bulldozers on the ground finishing the earth-work, cement mixers turning out concrete for runways yet to be built, and men in the open still clearing the brush off what had been grazing land a few weeks before.

“We have been told that German youth were taught mathematics, meteorology, communications, navigation and physics in public school. In that they were smart, for we had to take valuable time for such ground school work. However, we arranged pre-flight instruction as soon as possible. The old cadet requirement of college credits was waived, and a comprehensive test substituted which revealed a man’s potentialities, rather than his academic background.

“The majority of AAF personnel are specialists. We trained men to repair gun turrets and airplane propellers, to operate radio control towers, to take aerial photos, repair teletypewriter systems, and to perform a thousand other important tasks. The men were taught that in the field they would have to make most repairs on the spot. The results of this system have been satisfactory. Not long ago in the Mediterranean area, a tactical mission was scheduled from an advance airfield. Threatening weather made de-icing boots mandatory, but two or three of the boots on planes had been damaged by enemy bullets.

With no other rubber available, the resourceful ground crews took some emergency life jackets apart, and used the rubber in them to repair the boots. The mission went out in poor weather, caught and destroyed 13 enemy aircraft on the ground.

"The Commanding General of the Army Air Forces visited a Pacific air base built on a barren atoll. First, it had been necessary to build docks before supplies could be unloaded. The men then hammered out a smooth landing field on tough coral rubble, built barracks and other facilities. The mechanics improvised much of their equipment. A good engine hoist was made from the washed-up timbers of a wrecked ship. This well-equipped base was handling peak traffic in exactly 100 days from the time the first Americans waded ashore.

"The Army Air Forces knew that air crews and ground crews could be trained faster than in peacetime, although it was insisted that our standards of proficiency must not be lowered. Accordingly our cadets have always received more actual flying hours than the airmen of any other nation. There is no substitute for experience. Global operations put greater stress on formation flying, navigation, maintenance engineering, communications and weather reporting. Schools were set up to teach these subjects, and in many cases we had to give the teachers a brush-up before they could instruct the cadets. Special schools were established to train men for multi-engine aircraft, applied tactics, intelligence, troop carrier, anti-submarine and other functions.

"In Florida the Army Air Forces had a Tactical Center. This organization constitutes one of the most important elements for the final training of our air and ground crews, and the testing of equipment which will be used overseas. The men live, work and fight as they will abroad, in organizational units as large as a complete task force. Fighter, bomber and patrol missions are carried out from a dozen airfields in an actual theater of operations about the size of Sicily. Instructors and advisers are experienced officers. Many have just returned from combat. All branches of our air units receive such training—air and ground crews, communications men, service groups, weather men, medical units, anti-aircraft units, paratroops and glider troops. The Tactical Center is the last dress-rehearsal for air war.

"The Tactical Center has other duties, such as working out new tactics, techniques and procedures to be used by Air Forces already in action abroad. The standardization of technique of operations and employment of planes is not possible in this global war, for 90 times out of 100 an idea that succeeds in Italy will not work in New Guinea. Hence we must be versatile. Our tactics must be susceptible to change. Our commanding officers must have ingenuity and imagination. Today, the Army Air Forces are constantly working up new tactics. The refinements of skip-bombing in the Bismarck Sea Battle were worked out in Florida. So were the procedures and control techniques used in the Sicilian landings. Practically all equipment that originates at

Wright Field receives its final exhaustive tests in Florida. This includes planes, parts, tools and equipment of all kinds, from heated flying suits to parachute packs for Arctic wastes.

"The men in the Army Air Forces have been prepared in every way possible to raise their standard of efficiency, to reduce the hazards in combat, and to give them the upper hand over our enemy airmen before sending them into combat. After the airman has finished his individual training, he receives combat training both in the United States and in the theater of war before he goes on a mission. Even then, combat-wise officers watch out for the recruit airman as much as possible. In this business every man's life is in the hands of a team—a combat crew. As the war continues, emphasis naturally will shift from the training of vast numbers of new men to the training of replacements and to increasing the technical knowledge of the men already in service. When that time comes the United States will have an air force with a striking power unequalled in history.

"Our broad training program was facilitated by the cooperation of our citizens, our industries and our schools. The Civilian Pilot Training Program of the Civil Aeronautics Administration constituted a valuable pool from which personnel could be drawn. With Federal aid, vocational schools and public schools trained youths as mechanics and other technicians on a 24 hour a day basis. Government agencies lent assistance. The Coast and Geodetic Survey helped with maps and charts. The Forest Service provided information on non-critical materials. Well-known research men in industrial and university laboratories devoted themselves solely to aviation. Early in our program we realized that we must get square pegs for square holes and round ones for round holes, regardless of where they came from. Just because a man was a good pilot, it did not mean that he was an expert in making parachutes or supervising the laying of a steel landing mat. These experts came from all walks of life.

"As a result of tremendous effort, the Army Air Forces equipped and trained airmen to defeat the enemy who had been preparing feverishly for a decade—and shoot him down in aerial combat at a rate of never less than two planes for one in any theater of war, and at an overall rate of four to one. (February 2, 1942.—October 31, 1943.)

"Flying safety is vital both to our individual men and to our program; we need every soldier. Defeating the enemy depends on our ability to send skilled combat crews against him in increasing numbers. Let us not gloss over the fact that combat flying is a grim and dangerous business. If our only interest was flying safety in the United States, we would have every man fly a primary trainer on sunny days, and we could cut the accident record to almost zero. If we stopped flying and put the airplanes in hangars, we would have no accidents at all. But war is not fought that way. From the outset, the Army Air Forces have taught the men at home the maneuvers that they would



execute in combat abroad. In these maneuvers a few are bound to be injured or killed, but the overwhelming proportion of the men are better prepared to defeat the enemy. While still training in this country our pilots are taught formation flying. Formation flying demands a great deal of the men, and collisions in training inevitably will occur, but in combat a tight formation is often the airman's best protection. There has been an increase in the numbers of airplane accidents, but not out of proportion to the tremendous increase in the numbers of men now flying. The number of men now in training in the air every day is well over 120,000, approximately equal to the population of Camden, N. J., or Savannah, Ga. It is 25 times as many persons as were in the air in this country five years ago. During the fiscal year 1943 the Army Air Forces flew over 3,352,000,000 miles, which is equal to 134,000 trips around the world. This figure is domestic flying only; it excludes overseas or combat flying which also has increased greatly.

"Despite the tremendous expansion of Army Air Forces flying, the rate of accidents per 1,000 hours flown did not increase as anticipated in the fiscal year ending June 30, 1943, but was, in fact, reduced fractionally from .739 to .716. This rate of accidents was lower than the average rate for the 10 peacetime years of 1931-1940, although more than three times more miles were flown in 1943 than in the whole preceding 20-year period. As a result of the increased proportion of larger and heavier planes carrying more personnel, of faster military aircraft, and of newly trained pilots, the rate of fatal accidents was up

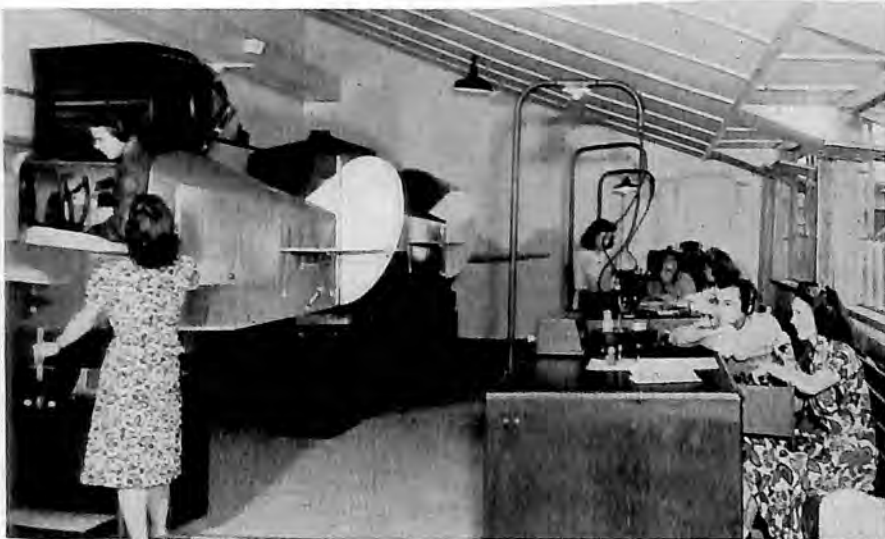

C.A.A. photo

## LINK INSTRUMENT TRAINING

Photo shows students at Furman University, Greenville, S. C.

fractionally from .077 in 1942 to .083 for the full fiscal year of 1943. The trend near the end of the year was downward, and in the last quarter the rate was below that of 1942. This record has been achieved despite the pressure of wartime training, and the fact that with our tremendous expansion, the experience level of our fliers was bound to be low. The Army Air Forces use every means to teach accident prevention, such as films, lectures, books, posters and periodic tests. Safety officers test flying equipment under all conditions, study take-offs, landing, weather conditions, airport clearances, and the like. Even matters of fliers' diets are studied and the information used where applicable. Every accident, however trivial, is investigated and the findings used to prevent future accidents. Basically, the accident record is good. Ninety-five out of each one hundred Army Air Forces pilots in training can be expected to fly through the next twelve months without a scratch."

Early in 1944 Naval Aviation reached its yearly goal in numbers of pilots and mechanics. The pilot training period was lengthened from 23 to 26 months as several new phases were added. They included a most significant development, the introduction of so-called shakedown training. In the first year of war, Naval aviators were so few and so vitally needed in the theaters of operation that they were rushed, at the end of operational training, to the Fleet. There they performed valiant deeds, despite their brief training experience. As the foe was first slowed down, then held, then forced back toward his homeland, time became available for shakedown training.

When the Naval aviator completed his operational training he was ordered to a squadron being formed in the States. There he met his squadron mates, and they trained as a squadron in advanced tactics. After two to three months of this training, the squadron was assigned to a forming air group. There the squadron met the other squadrons with which it was to operate as an air group. As a group then the squadrons trained from one to three months longer. During this phase the air group executed simulated combat missions, such as they would be called upon later to execute from carrier flight decks, or land bases, in the combat areas. In the case of carrier groups, all the battle equipment to be found in the island structure of a flattop—battle radio, bridge, flight control and air plot—was set up dockside on land. From these mockups the fighter, bomber and torpedo squadrons were sent out over the Atlantic or Pacific from American bases to search out and attack and to return to base. During this squadron and group training, the aviators actually were attached to Fleet commands. Technically, therefore, the shakedown work was not training. Actually, of course, it was preparing pilots and crews even more polished and destructive than the heroes of 1942 and 1943 who met the Jap's first surge and threw him back. This shakedown training was carried on at a half dozen Naval air stations on the East and West

Coasts. Generally it lasted until completion of the carrier to which the group was assigned, at which time the group joined the flattop and went to sea for a shakedown cruise, thence to the battle areas. Veteran combat pilots and others were brought back from the front to assist in training operations.

Outstanding organizational development came at year-end when the three chief Naval air training commands were placed under a single head, Rear Adm. George D. Murray, one of the first officers to be designated a Naval aviator, and during the first year of war captain of the carrier *Enterprise*. Under Adm. Murray were placed the Naval air primary, intermediate and operational training commands, with headquarters at Pensacola, the first U. S. Naval air station, where Adm. Murray had gone to earn his wings when the station opened in 1914.

Another significant organizational move was the creation of a Naval airship training command. All lighter-than-air training was centered under the new command, at the Naval air stations at Lakehurst, N. J., and Moffett Field, Sunnyvale, Calif. Rear Adm. Charles E. Rosendahl, outstanding American lighter-than-air expert, was advanced to flag rank and named first Chief of the Airship Training Command, which turned out the pilots and crews to man the Navy's blimp convoy fleet.

The aviation cadet in 1944 went through the same stages of training as did his 1942 predecessor, except for a seasoning course at an air station at first, and then the final shakedown course, as explained in earlier paragraphs. He spent three months in flight preparatory school, at one of the colleges the Navy had taken over, for instruction in physics, mathematics and other classroom subjects so necessary to the Naval aviator if he is to become the expert navigator he must be in order to carry out missions over the trackless seas. Next, he had to spend about two months at a Civil Aeronautics Administration-War Training Service School. Here he was indoctrinated in the theory and principle of flight, and received from 30 to 50 hours of flight training by CAA contractors under Navy supervision. There, those who proved inherently unqualified for flying were weeded out.

From that course the cadet went to one of the pre-flight schools for three months. It was at pre-flight that the emphasis was put on physical conditioning. At the outset the theory had been that in this war the Naval aviator would have to be tough physically to survive. It was proven a sound principle hundreds of times in the South Pacific where our Naval aviators, forced or shot down, often had to spend weeks on jungle islands, dependent on their own strength and resourcefulness. Often they had to elude Jap patrols, or skirmish with them. They had to feed themselves on roots and other jungle fare. They had to minister to their own wounds, sleep in the malarial, insect-infested open. All these things they were able to do because



#### TRAINING IN RYAN PLANES

Hundreds of U. S. Army Air Forces pilots received instruction in Ryan PT-22 primary training planes at schools operated for the Army Air Forces by the Ryan School of Aeronautics at Hemet, Calif., and Tucson, Ariz.

they were trained to do them at pre-flight school. At pre-flight, of course, the aviation cadet kept up his class work and studies in military arts.

From pre-flight, the cadet went to primary training where he got his first Navy flight training. Here he soloed, practiced short cross-country flights, flew simple maneuvers in small formations, learned aerobatics and had some night flying. After three months in primary, he went either to Pensacola or Corpus Christi for his intermediate work, where he flew the Consolidated-Vultee Valiant or North American Texan, of 225 and 450 horsepower, respectively. Here he began to specialize as a fighter, dive bomber, or torpedo bomber pilot. Here also he might specialize in flying boat operations.

At the end of his three months in intermediate, the cadet was commissioned Ensign and, in most instances, advanced to operational training. In operational, he stepped into combat aircraft, into Grumman Hellcat or Vought Corsair fighters, into Douglas Dauntless or Curtiss Helldiver dive bombers or into Grumman Avenger torpedo bombers. He now was becoming a thorough specialist in one of the

fighting aviation arts. He trained in only one, to expedite the flow of combat pilots to the Fleet. Those Corpus Christi and Pensacola graduates who did not go into operational, with its headquarters at Jacksonville, Fla., were assigned to patrol squadrons, to further training for flying with the Naval Air Transport Service, or as instructors.

The Naval air technical training command, which reached an annual output of 100,000 machinist's mates, metalsmiths, ordnancemen and radiomen, supported a curriculum comparing favorably with the finest technical institutions in the country. An outstanding development was the breaking-down into specialized categories the main ratings which had been turned out before—machinists, metalsmiths, radiomen and ordnancemen. As new American warcraft became more complex in their structure, it was necessary to train machinist mates specializing in one phase of their trade, as experts on propellers, engines, carburetors and other auxiliaries.

Following a 90-day course in one of the technical branches, these enlisted specialists could volunteer as air gunners. Those who were accepted received four weeks training in free gunnery, and then took to the air with their pilot-officer commanders. From the ranks of these air gunners came many of the war's heroes.

One of the developments in the technical training command during 1943 was the training of enlisted WAVES as machinist mates and metalsmiths. This revolutionary move, scoffed at by many at its inception, produced splendid results. The girls soon demonstrated their ability, and the first graduates were working on warplanes throughout the country early in 1944. The WAVES also made their mark as control tower operators, Link Trainer instructors and in many other aviation capacities, thereby freeing men for combat duty.

In a statement made public on February 17, 1944, Charles I. Stanton, Administrator of Civil Aeronautics, said that aviation, today and in the future, is everybody's business. He spoke of the widespread interest among the younger generation. "Aware of that interest," said Mr. Stanton, "the Civil Aeronautics Administration initiated a program about two years ago to introduce pre-flight aeronautics into the curriculum of the high schools and eventually of the primary schools in the country. The response to that program has been really astonishing on the part of both teachers and pupils. Pre-flight aeronautics courses are now an integral part of the curriculum in more than half of the 28,000 high schools in the country. These studies have not supplanted existing courses. They have supplemented them, enriching their content, giving them a new focus and relevance.

One of civil aviation's outstanding contributions to the war effort was the flight instructor. Veteran fliers by the hundreds started training pilots long before Pearl Harbor, and by the time of the Japanese attack, they had produced a reservoir of pilots numbering about



100,000. At that time, the instructors numbered about 650 in the Civil Aeronautics Administration's Civilian Pilot Training program alone. Several times throughout the war, special calls for instructors were issued. The Civil Aeronautics Administration once was asked by the Army Air Forces to produce an additional 2,000 instructors within about 90 days. At the time, an instructor training program was in progress, and there were no more prospects immediately in sight. The CAA had turned to the pilots of the country and enrolled civilian pilots from all walks of life back into flying, giving them refresher courses in instruction, and feeding them into the civilian schools doing contract training work for the Air Forces.

This recruiting campaign turned up fliers of all ages, some of whom had started flying in the first world war. Eventually, enough of these oldtimers were in the service to produce an organization termed the "Methuselah Club" consisting of fliers with the Southwest Airways at Phoenix, Ariz., and other flight centers in the Southwest.

Because of the high physical standards set by the armed forces, none of these men was acceptable for combat flying, and not all were acceptable for ferrying or in the transport commands. It probably was fortunate that these high physical standards prevented their use on active duty, because as a result they were able to be used for the production of a large pool of combat pilots. These veterans of commercial and private flying operations in the United States have fought the war by proxy, for the most part having started beginners on their way to flying. Studies in instruction technique and methods convinced researchers that the most skilled type of instruction should be employed in giving the first flying lessons. Thus the ability of the young warrior in a fighting plane at the front rested as much on the instructor who first taught him as it did upon the long list of teachers who later provided military and combat flying instruction.

Not all the instructors were oldtimers, however. There were several thousands of instructors who, for various reasons failed to get into the Army or Navy flying force and turned to instructing, just to be able to fly. These men started as beginners, learned to fly and then were trained as instructors, mostly in the Civilian Pilot Training program of the Civil Aeronautics Administration. They failed to get into the battle as fliers, and their instructing duties called for onerous wearing flights around a single field, training one novice after another until they frequently suffered from the monotony of the task. The nation owed them gratitude for perseverance and patience.

Women instructors, excluded from most of the war's flying activities, made an important contribution to the war effort by training young pilots. The decision of the War Department to set a top limit of 35 years for women pilots for ferrying work resulted in freezing many of these experienced and valuable instructors in their work. Scores of others weighed the relative importance of ferrying a

maximum of 50 planes a year against training 50 pilots a year, and chose instruction. In 1943, 150 women instructors were certificated.

On January 28, 1944, R. McLean Stewart, Executive Director of Training, CAA, stated: "In 1943 more than 207,000 young men received training as pilots in colleges and flight training centers cooperating in this work under arrangements with the War Training Service of the Civil Aeronautics Administration. The total of 207,000 men includes none but personnel of the Army Air Forces and Naval Aviation. During the year, all Naval aviation cadets and all the men assigned to training in the air forces college program for air crew were given their initial training as pilots at the hands of civil aviation working in close association with the colleges. Since the inception of the Civilian Pilot Training Act in 1939, more than 9,064,000 hours of flight training have been given to student pilots. On December 31, 1943, we were using 7,564 airplanes in the training program.

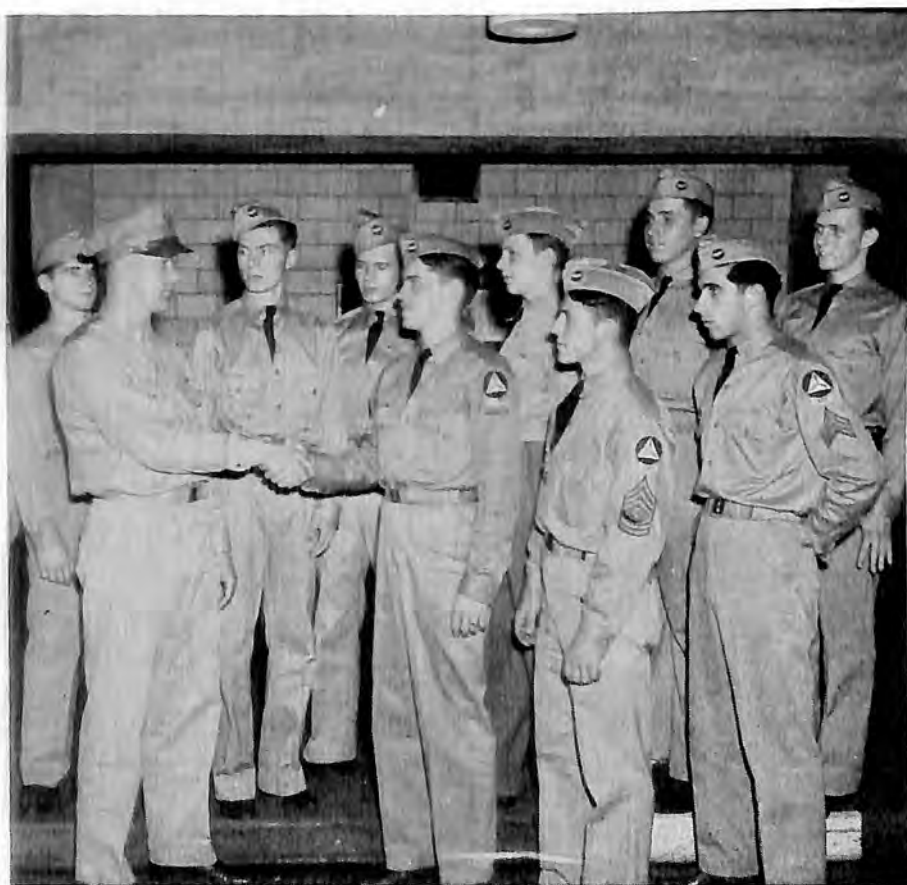

CAP CADETS FOR AIR FORCES

The Minneapolis, Minn., contingent photographed as they were leaving to join the Army Air Forces.

"Civilian flight instructors have been a great force in building up our military and naval air arm. More than 10,000 of these civilian instructors up to now have been employed in the training of pilots for the Army and Navy. This total includes those employed at centers under direct contract with the armed services as well as at centers working under arrangements with the CAA.

"Now a point has been reached at which it has become possible for the Army Air Forces to state that it is no longer necessary to employ the facilities of civilian aviation in the production of flight instructors for the Army. The Naval air arm also finds that ample facilities will soon be available within its own establishments to provide for all of its aviation training needs without employing the facilities of civil aviation."

All the leading air transport companies were training personnel for the air forces, some as transport pilots and navigators and others for maintenance and repair work. The Pan American Airways Section at the University of Miami, Fla., had an honor roll of 175 graduates decorated for work over many battlefronts. Pan American's flying classrooms logged 13,705,200 miles of night flying over the Miami area in three years. Pan American in 1943 trained 20 times the number of flight crews turned out in 1942. Many of the air transport companies gave transition training to ATC pilots, ran schools for ATC mechanic personnel and also trained mechanics for the modification centers. Nearly all the aircraft manufacturers operated courses in cooperation with local schools for training technicians, including both men and women.

Curtiss-Wright was one of the first large companies to realize that trained men and women build better airplanes. It developed a well rounded educational program to train personnel in all phases of plant operation. Highlighting the Curtiss-Wright training program were the Curtiss-Wright training school, the engineering and management institute and the engineering cadettes. Other features included pre-foremanship training, foremanship training, observation trainees and courses sponsored by Curtiss and presented through local high and technical schools. The training school was established to familiarize new employees with shop methods and equipment. The enrollment was nearly 90 per cent women with a recent influx of 16-17 year old youths. Under actual shop conditions, the new employees were taught shop procedure and the correct use of the tools they would use when sent into the plants. The engineering and management institute was designed to train qualified men and women in specialized fields of the airplane industry. Terminology, plant procedure, engineering mathematics, blue print analysis, time and motion study and factory management were a few of the subjects stressed during the period of training. Students attended classes eight hours a day and on the completion of their course were assigned to a job where their particular

talents could be best utilized. The Curtiss engineering cadettes included young women who were selected from various colleges throughout the country. Sent to one of 10 accredited engineering universities, the girls were given an extensive 44-week, two semester course and trained in important detail engineering jobs. On the completion of their course, the cadettes were assigned to one of the Curtiss plants.

The leading civil flight and mechanic training schools had a splendid record of achievement in wartime aviation training.

In 1943 the Academy of Aeronautics, New York Municipal Airport, LaGuardia Field, trained more than 6,600 students. During the year two major changes occurred: first the completion of the Army Air Forces Technical Training Command program for instructing aviation mechanics, and second the influx of women into the institution for aviation training, both engineering and mechanical. Several classes of young women were trained as engineering aides for Chance Vought Division of United Aircraft, to work in its engineering department at Stratford, Conn., upon graduation. Other groups were similarly trained for American Airlines and Hub Industries. Upgrading courses for aviation mechanics already in the employ of various air lines at LaGuardia Field also were conducted. The War Service Mechanics program for both men and women was continued through the joint sponsorship and cooperation of the U. S. Department of Education, the Board of Regents of the State of New York, the U. S. Civil Service and the Army Air Forces. Upon completion of these courses, the graduates were employed in 3rd and 4th echelon maintenance work at the Army Air Depot, Rome, N. Y. Pre-induction courses in mechanics also were given for youths soon to enter service.

Cal-Aero, Mira Loma and Polaris Flight Academies, Major C. C. Moseley's civilian contract schools for Army Air Forces cadet training at Ontario, Oxnard and Lancaster, Calif., graduated their 15,000th cadet early in December, 1943. Most important development of the year was the conversion of Cal-Aero Academy, one of the original "nine little Randolph Fields," from primary to basic training, at Army request. While all Air Force primary instruction was given by civilian contractors, only three schools had hitherto been awarded basic training contracts, one of them being Polaris Flight Academy, converted the previous year, also at Army request, from Royal Air Force to American basic training. Major expansion, details of which could not be disclosed, brought all three schools far beyond their original estimated maximum during 1943, and they boasted a safety record of more than 102,000 seat flying hours per cadet fatality. At the close of the year, awards to graduates of the three schools for action in combat neared the 700 mark, these not including oak leaf clusters denoting additional awards of the same medal.

Curtiss-Wright Technical Institute, Major C. C. Moseley's veteran

school of aviation mechanics and aeronautical engineering at Glendale, Calif., was a teeming mixture of military and civilian activity during 1943 with trends at the latter part of the year indicating interesting developments for 1944. Originally the only technical school on the West Coast contracted for Army Air Forces mechanics training, the institute ended its more than three-year program for the Army early in November, in common with the nation's other civilian contract technical schools. Thousands of Army Air Force ground crew members, a preponderance of them already active in every American theater of operations, had received their training at Curtiss-Wright Tech.

Unlike many of the Army contract schools, however, Curtiss-Wright Tech also maintained a heavy civilian enrollment while the military program was being carried on and as the Army training neared an end, a heavy increase of new civilian students was noted. Most interesting of these, perhaps, were scores of foreign students from friendly nations in all parts of the globe. To cite one example, two young men from India and three from the opposite end of the world, Iceland, arrived in a single week to begin their studies. So heavy became the Chinese enrollment that a Chinese Students Association was formed, while the Latin-American nations continued to expand their representations.

On the American side, enrollment of young men below draft age and those who in other times would have sought academic higher education tended to prove the school's belief that the value of technical training, as brought to light by the war, would in future bring an increasing popularity of this form of study over the academic classes taken as a matter of course by preceding generations.

As the year ended, the school experimentally had under enrollment, in cooperation with the State of California Rehabilitation Service, several blind students. These men were being taught such intricate operations as the assembly of 400-part aircraft engine starters, with early indication that the move would be successful. Necessity for vast rehabilitation work for those injured in the war was obvious, and it appeared probable that this would, in the future, form an important branch of Curtiss-Wright Tech's teaching.

So successful had the school become in constructing its own special training apparatus that a contract was awarded by the Army Air Forces for the construction of a large number of Mobile Training Units for the B-24 Liberator bomber, mounted on huge trucks. This new branch of the school's activities was to be expanded into other manufacturing work during 1944.

The Casey Jones School of Aeronautics, Inc., Newark, N. J. trained 7,000 students in 1943. The school continued its large-scale training of Army Air Forces Technical Training Command aviation mechanics the major part of the year. With the finish of the Army training contract in October, most of the facilities of the school were



turned to instruction of War Service Mechanics, in courses similar to those in which many hundreds of students previously had been trained. These specialist courses, for both men and women, were given in cooperation with the U. S. Department of Education, the Board of Education of the State of New Jersey, the U. S. Civil Service, and the Army Air Forces. Pre-induction courses in mechanics also were given for youths soon to enter service. While a considerable number of aeronautical engineering students entered the armed forces, an impressive total remained at their drafting boards in the school to finish their complete, practical courses in this important field of aviation development. Young men, carefully selected by the governments of countries south of the United States to receive aeronautical instruction, continued to be taught. The outstanding change of 1943 was greater emphasis on the training of women as aviation mechanics.

Parks Air College, East St. Louis, Ill., continued with its college training in three courses, Aviation Operations Engineering, Aviation Maintenance Engineering and Aeronautical Engineering. In the aviation operations engineering course students still were given the chance to major in professional flight with 240 hours of flight instruc-

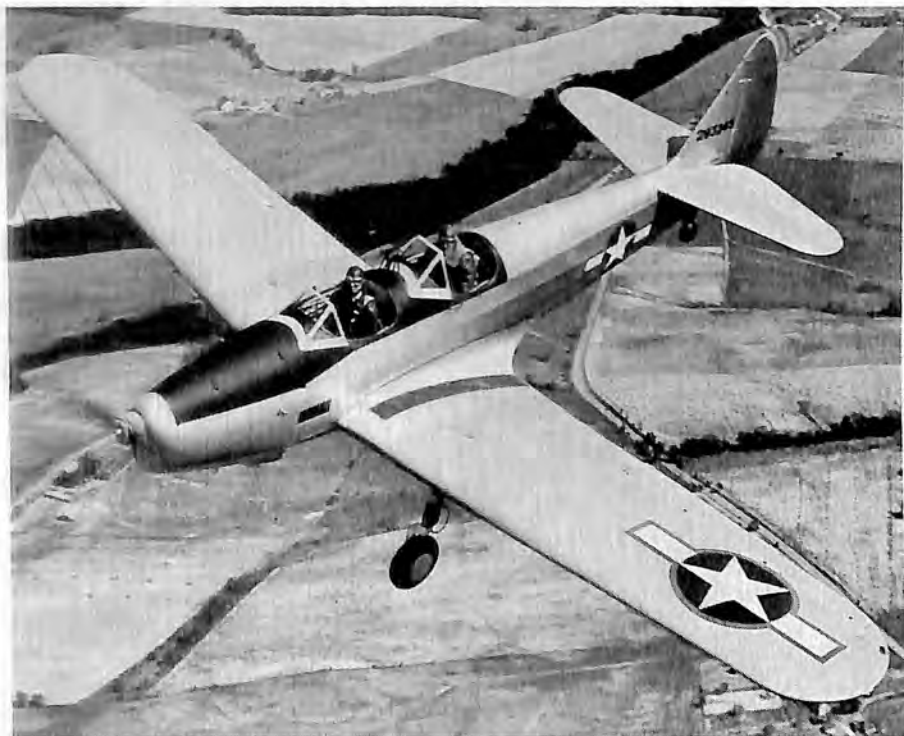

THE FAIRCHILD CORNELL TRAINER

The PT-19 with Ranger engine.

tion offered. All courses were for two years with the exception of aeronautical engineering. This school required two and a quarter years of training.

More than 10,000 aviation cadets were being trained each year in primary flight work for the U. S. Army Air Forces at the parent Parks school and at the four subsidiary schools, the Alabama Institute at Tuscaloosa, the Mississippi Institute of Aeronautics at Jackson, the Missouri Institute of Aeronautics at Sikeston and the Cape Institute of Aeronautics at Cape Girardeau, Mo. In addition to flight training for servicemen, CAA war service training was carried on at Tuscaloosa. Graduates of the primary flight training at Parks Air College since 1939 until October of last year had received 103 decorations for combat work with the air forces.

The Parks civilian college continued to aid the industry with practically 100 per cent of all graduates serving in positions of responsibility in the war effort. Enrollments were considered satisfactory in keeping with the condition of the times.

Roosevelt Aviation School, Roosevelt Field, Mineola, N. Y., completed a contract for the training of soldiers as aviation mechanics for the Army Air Forces, but continued its commercial school activities with an average attendance of about 150 civilian students. As a war-time measure, the School specialized in a six month's Aircraft Engine Mechanics Course which prepared for the test given by the Civil Aeronautics Administration for the aircraft engine certificate of competency. Starting dates for this course for 1944 were designated as January 31, March 27, July 7 and September 5. Special lecture courses presented by instructors of Roosevelt Aviation School were offered to employees of Roosevelt Field which was engaged in an extensive airplane modification program for the Navy.

The Ryan School of Aeronautics, San Diego, Calif., continued to expand its two primary training bases operated under contract for the Army Air Forces. Ryan was one of the nine schools originally chosen by the Army to handle cadet training in 1939, when it already had accumulated nearly 20 years experience in commercial training of pilots, mechanics and engineers. During 1943 this school trained 11 times as many cadets as it did before Pearl Harbor. It reduced cadet training time 30 per cent from prewar days; and it trained each cadet at a considerably reduced cost to the Government.

Four years of experience in training military pilots plus nearly 20 years of active commercial pilot training enabled Ryan to establish two of the most efficient civilian contract flying schools under contract to the Army. All of Ryan's key flight personnel had long experience with the organization, with the result that all training procedures were so well established that the elimination rate was greatly reduced and overall training efficiency brought to an extremely high point. Although administrative headquarters for the school were located at San

Diego, its two operating bases were at Hemet, Calif., and Tucson, Ariz. Its Hemet base completed its third year of operation in 1943, while the Tucson school was in its second year.

Ryan attracted considerable attention in the industry by installing a new system which increased its flight hours per plane per day from the old average of  $4\frac{1}{2}$  hours to a new average of  $7\frac{1}{2}$  hours. Some of the features of the new system were a two-way take-off arrangement whereby solo planes took off at one side of the field and turned left, while dual planes took off at the other side and turned right, thus reducing take-off time one third; discontinuance of the former practice of reserving specific ships for flight officers or civilian personnel; spot-parking of incoming planes for fast gassing; close scheduling of solo flights to eliminate all idle time; and advance notice to students and instructors of their flying schedule and the plane assigned to them.

Because of the shortage of manpower and new equipment, Ryan technicians had to develop ingenious methods to increase the efficiency of field operations and maintenance procedures. Typical of the low-cost methods of speeding "production" on the flight line was the development of tug cars to tow airplanes on the flight line, a handy-man hoist for field and hangar use and installation of gas truck booms



AT CAL-AERO FLIGHT ACADEMY  
Basic flight students ready to take the air.

to speed servicing of planes between flights. The tug airplane tow cars were converted from standard 1930 Ford cars by cutting down the wheel base and installing special tow equipment. The hydraulic hoist cars similarly were developed from used automotive equipment available through second hand car dealers. Installation of special booms on the gasoline trucks, together with meters in the driver's cab made it possible to speed gassing and oiling service, particularly by women mechanics.

In addition to its Army training program, Ryan offered specialized home-study instruction to aircraft factory workers and the general public through the affiliated Ryan Aeronautical Institute. Texts for the Ryan correspondence courses were written by leading industry authorities, all men with long practical experience in aviation. Several of the nation's largest aircraft factories bought the Ryan training courses for their workers who wished to take it. More than 3,000 factory employees took instruction from the Ryan Aeronautical Institute in 1943.

Spartan School of Aeronautics, with headquarters in Tulsa, Okla., offered civilian courses in Aeronautical Engineering, Airline Maintenance Engineering, Airline Pilot, Commercial Flight Instructor, Commercial Pilot, Private Pilot, Flight Instructor Rating, Instrument Rating, Weather Forecasting, Airline Service (A&E) Mechanic, Aircraft Mechanic, Engine Mechanic, Radio Communications, Instrument Technician and Women's Instrument Technician. Enrollments were maintained at a satisfactory level, and for organizational purposes civil departments were divided into the College of Aeronautical Engineering, School of Flight, School of Mechanics, School of Meteorology, School of Communications, and School of Instruments. The College of Aeronautical Engineering was set apart as a separate division of Spartan School and was accredited by the Oklahoma State Regents for Higher Education. It was admitted to the Oklahoma State System of Higher Education as a private college member and approved to issue the degree of Associate in Arts in Aeronautical Engineering to graduating students.

Complete civilian schedules were to be maintained in 1944, although the majority of personnel continued to be engaged in providing primary ground school and flight training to Army cadets at Tulsa and the Muskogee, Okla., branch. No. 3. British Flying Training School, operated by Spartan at Miami, Okla., gave primary and advanced training to English and American cadets enrolled in the school. British graduates were assigned to operational training in England upon completion of training.

In November, 1943, Spartan School of Aeronautics was selected as a training agency for the Inter-American Aviation Mechanic Training program under joint sponsorship of the Department of State and the Civil Aeronautics Administration. The first class comprised 67



students from 12 Central and South American countries. A second group was expected in the spring of 1944. Spartan School entered 1944 with approximately 2,000 employees, 1,200 students under instruction, and a total of 54 modern buildings at its three locations.

Stewart Technical School, New York, finished its 1943 technical training program with a record of 34 years to its credit. Since 1929 it had specialized in training technicians for the aircraft industry. The school was one of the first approved by CAA as an aircraft and aircraft engine mechanic school, also as an aircraft repair station. An aeronautical drafting course, including detail design, also was offered by the School. During 1943, a large number of drafting students were graduated and employed in responsible engineering department positions.

Suspension of the civilian mechanic courses was continued until June, 1943, in order to expedite the war training program of the Army Air Forces. A special engine course of 15 weeks (720 hours) was given on different types of high powered aircraft engines and



AT ROOSEVELT AVIATION SCHOOL  
Testing an altimeter in the instrument department.



accessories. Approximately 2,000 technicians had graduated since Pearl Harbor. The Stewart School provided housing and messing for the Army students.

In June, 1943, the Government approved aircraft and aircraft engine mechanic courses again were opened to civilians, and a large number of young men enrolled in preparation for induction into the Army Air Forces. Other students enrolled who were planning post war careers in aviation.

During 1944, the facilities of the school were to be devoted to training civilians in the Mechanic Courses in preparation for mechanic ratings. Intensive specialized courses also were to be given to employees of several air lines.

During 1943 E. W. Wiggins Airways, Inc., continued to operate flying schools outside the vital defense zone, having closed up all its bases in this zone with the exception of the base at Norwood, Mass. War Training Service contracts were continued in operation at Concord, N. H., and Columbia, Mo., while an affiliate, Wiggins-Marden Aero Corporation, continued its Army contract flight school at Camden, Ark. At the Norwood Airport repair and overhaul facilities for engines and aircraft were maintained in order to service war training service airplanes being used at other Wiggins bases. The Government-approved civilian aviation mechanics school continued to be conducted at the Norwood base.

The New England Aircraft School of Boston, located at the Logan International Airport, Boston, Mass., completed its four-year mechanics training program for the Army Air Forces. Civilian training activities were carried out in the school's new building at the Commonwealth Airport, Boston, designed especially for the training of aviation mechanics.

The Aeronautical University, Inc., Chicago, Ill., offered courses in aeronautical engineering and certified airplane engine mechanics. A Bachelor of Science degree was awarded to graduate aeronautical engineers. The mechanics course was approved by the CAA, and the engineering course was accredited by the Illinois Board of Education. During 1943, the school completed its training contracts with the Army Air Forces, having conducted that program for a period of four and one-half years. At the peak of the Army program there were 650 soldiers enrolled, and 169 instructors.

The Aviation Institute of Technology, Long Island City, New York, operated by Frank Ambrose, had a contract with the State of New York to train aviation mechanics, and was making extensive preparations for training war veterans under the rehabilitation program.

Lodwick Aviation Military Academy, Avon Park, Fla., continued giving primary flight training to aviation cadets of the Army Air Forces. A new two story barracks was erected alongside the hotel

barracks, to take care of the increased number of cadets. An additional hangar and Link trainer building were erected at the main airport.

Expansion of training facilities which included the construction of a one-story Link trainer building, a two-story administrative and ground school building and a new metal hangar in addition to enlarging the mess hall and soil asphaltting large areas of the main airport featured the primary flight training activities of the Lodwick School of Aeronautics, Lakeland, Fla. The school, operating under the supervision of the Eastern Flying Training Command, AAF, Maxwell Field, Ala., was formerly the Lakeland School of Aeronautics. More than 500 civilian employees were on the payroll. Girls to a large extent replaced young men on the flight line for servicing and gassing of the Boeing Caydet trainers used for flight training. Some qualified as student mechanics and a few were advanced to assignments in the hangars working under the supervision of licensed mechanics.

The Weems System of Navigation, Annapolis, Md., started in 1927 with the publication of the Line of Position Book, a short, easy method for solving the line of position from an assumed position. This method was well received, and became known as the Weems System of Navigation. Realizing that air navigation demanded shorter, faster and easier methods than those in use for marine navigation, Capt. P. V. H. Weems then began a period of developing, and encouraging others interested in air navigation to develop, streamlined methods

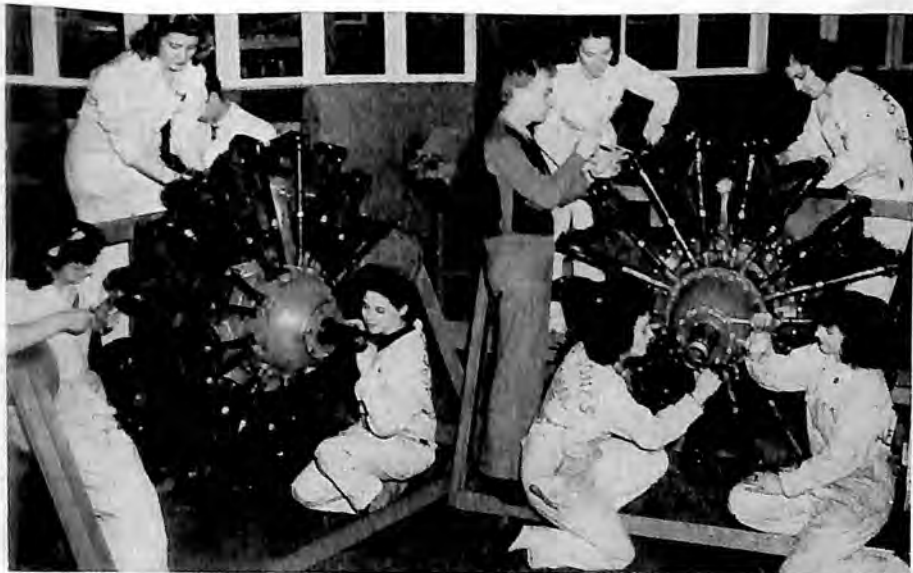

AT CASEY JONES SCHOOL OF AERONAUTICS  
War service mechanics specializing in engines.

particularly meeting air navigation needs. Successively he presented the Mark II Aircraft Plotter, the second-setting watch, skeleton navigation charts of the earth, Dalton aircraft computers, and the Star Altitude Curves, all of which were being used in air navigation. Weems produced one of the first texts dealing with air navigation exclusively, and periodically revised the text to keep it in line with modern navigation developments.

The first home study course in air navigation was a Weems publication. In 1935 resident study courses were offered at Annapolis, Md. Branch schools were established for the Weems System of Navigation in various cities throughout the United States.



AT STEWART TECHNICAL SCHOOL  
Students overhauling an aircraft engine.



## CHAPTER VIII

### WORK OF THE FEDERAL BUREAUS

**T**HE various Government bureaus dealing with aviation problems cast up by the war in the air made important contributions to the overall pattern for victory, their accomplishments providing impetus to steady progress in the development of American air power.

#### Aircraft Production Board

The Aircraft Production Board, authorized in December 1942, served its first full year of operation in 1943. The successful progress of the aircraft production program during 1943 reflects the satisfactory operation of the Board. The Board was formed on December 9, 1942, under the chairmanship of C. E. Wilson, executive vice chairman of the War Production Board. Its other members were Lt. Gen. Wm. S. Knudsen, Major Gen. O. P. Echols, Rear Adm. E. M. Pace and T. P. Wright. Weekly meetings of the Board were held throughout the year. All phases of the aircraft production program were discussed, with emphasis being laid on the troubles which were in any way retarding progress of the production program.

Reporting directly to the Board through the recorder were three agencies located in the W.P.B. buildings—the Civil Requirements Branch, dealing with matters pertaining to civilian aircraft; the Project Service Branch, handling expediting of facilities; and the Project Rating Branch, in charge of the priority ratings of facility projects.

The executive agency of the Aircraft Production Board was the Aircraft Resources Control Office, consisting of a representative of the Army Air Forces and of the Navy Bureau of Aeronautics under the direction of T. P. Wright, a member of the parent Board. The Aircraft Resources Control Office had the following prescribed functions: The publication of aircraft programs. These airplane and engine schedules, having been coordinated with the Services and prepared in suitable form, were presented to the Joint Aircraft Committee for consideration and then to the Aircraft Production Board for final approval. The Aircraft Resources Control Office also had jurisdiction over the Resources Division, dealing principally with materials. There are several other branches of the Resources Division, including components, controlled materials, non-controlled materials, tools and priorities. The Conservation and Standards Division coordinated between the Services, W.P.B. and the industry matters pertaining to conservation and standardization of materials for the aircraft program.

In addition, there was a Manpower Division, which carried out the coordination work necessary in reconciling the functions of the War Manpower Commission, the Offices of the Under Secretary of War and of the Under Secretary of the Navy, and the War Production Board, insofar as aircraft requirements were concerned. A report was issued giving the overall monthly manpower requirements for the approved air program based on the particular "W" series schedule latest approved by the Aircraft Production Board.

There also was a Statistical Branch of A.R.C.O., which handled the preparation and dissemination of statistical information pertaining to the air program.

Reporting to the Aircraft Resources Control Office was the Aircraft Scheduling Unit located at Wright Field, Dayton, O. This group prepared the requirements for the air program in terms of materials, for presentation to W.P.B. through A.R.C.O. as the claimant agency for the air program. In addition, it handled the allocation and distribution of materials and handled all industry contacts for the Aircraft Resources Control Office.

In the early days of the program, 1940 and 1941, machine tools were a critical item. This bottleneck soon developed into troubles on overall facilities which, in turn, gave way to materials as the principal difficulty in meeting the program. During the early part of 1943, the material situation was bad in a number of fields; but toward the end of the third quarter and, particularly, in the fourth quarter, material problems quite largely disappeared in favor of the latest bottleneck, manpower. Much attention was given to the manpower problem during the last quarter of 1943; and toward the end of the year, due to the intensive efforts carried out by the various expedients initiated by the Aircraft Production Board, the situation became reasonably in balance in most localities, although, at the start of 1944, there were still several critical manpower areas.

Throughout the latter part of 1943, the Board spent considerable effort on the problem of combatting the short term over-optimism on the war in general, which was springing up prematurely as more and more consideration of reconversion to peace time manufacture engaged the attention of industry and officials.

Another important function which the Aircraft Production Board carried out was the establishment of a sound scheduling policy which assured the attainment of the greatest possible number of airplanes of the types required. This policy might be called selective incentive scheduling, and contemplated the scheduling of trainers and older types of planes to the exact realistic output attainable. Then tactical types were slightly over-scheduled so as to get as many as possible, but without chance of allocating too much material to such programs. Then, however, the most needed types, including the long-range bombers and fighters, were scheduled with a greater incentive, so as



to assure getting the maximum possible number of these types most desperately needed in the war effort.

1943 saw the real fruition of the aircraft program with just under 86,000 airplanes delivered. However, as the Aircraft Production Board had consistently stated, the true efforts of the industry in producing aircraft should be judged in terms of weight rather than numbers. Compared on this basis, and using an index of 100 for the output in 1942, it was found that the 1941 index was 29, the 1943 index 254, with an anticipated index for 1944 of 350. That means that the 1943 production of aircraft in terms of size and types produced in 1942 would have totaled 122,000 airplanes, a close approximation to the President's program as established in January, 1942. In 1944, on this basis, the production would be 167,000 airplanes, although in actual numbers, because of the large size and weight of the planes to be delivered, the number promised to be slightly over 100,000 in 1944.

Therefore, to recapitulate for 1944, it was anticipated that the number of airplanes delivered would be greater than 100,000; the average weight of each airplane would be greater than 10,000 pounds, and the total weight of aircraft delivered would be over 1,000,000,000 pounds.

Another problem on which the Aircraft Production Board concentrated in 1943, was that of improvement in manufacturing efficiency, as indicated by effective utilization of labor. Through Report 17A of the Aircraft Resources Control Office, the system of measur-



C. A. A. photo

#### THE HEART OF AIR TRAFFIC CONTROL

The U. S. Civil Aeronautics Administration's electric air traffic control posting board at Washington, D. C., airport.

ing efficiency of labor utilization in terms of pounds of output per-day per-employee was devised and, through the last half of the year, it developed that the index of the industry in general was raised to such an extent that the equivalent of 100,000 persons was saved because of efficiency increase when compared to what would have been required had the mid-year efficiency prevailed.

#### Aviation Division, Department of State

The Aviation Division of the Department of State was created on January 15, 1944, to replace the Aviation Section of the former Division of International Communications. The functions of the Aviation Division included the negotiation of international agreements on such subjects as air navigation, the acquisition of landing rights and the operation of air transport services, the reciprocal issuance of airman certificates and the reciprocal recognition of certificates of airworthiness for export, agreements on various phases of international air law, the granting of foreign flight permits; and cooperation with other interested Government agencies with respect to foreign allocations of certain types of aircraft, the training of foreign aviation personnel under American auspices, and the granting of priorities for foreign air travel. The Aviation Division also was in charge of the technical work connected with participation by the United States in international aviation conferences, and cooperated in the making of arrangements for participation by representatives of the United States in the work of the International Technical Committee of Aerial Legal Experts and the Permanent American Aeronautical Commission.

#### Civil Aeronautics Administration

The work of the Civil Aeronautics Administration continued to be closely geared to the war in 1943, making vital contributions to victory in the field of airways, airports, pilot training and air safety. Traffic along the 35,000 miles of Federal Airways system showed a huge increase. More than 16,000,000 aircraft movements were recorded at C.A.A. traffic control centers, a rise of 7,000,000 over 1942. More than 85 per cent of the traffic consisted of military planes flying to other parts of the country or bound overseas to distant battlefronts. C.A.A. airways and airport engineers carried out many foreign assignments at the request of the Army and Navy air forces. All this work was necessarily confidential in nature.

As traffic began to approach capacity on certain busy sectors of the airways, C.A.A. experts intensified study of new control devices—electrical boards for automatic posting of flight progress reports, omnidirectional radio markers emitting signals in all directions in contrast to conventional radio range stations marking four set courses, and electronic anti-collision devices enabling pilots to see on their instrument panels the location of all planes within the danger zone

around them. Notwithstanding heavier loading and greater utilization of air line planes, a new safety record was set. Miles flown per fatal accident in domestic air carrier operations reached an all time high of 46,560,835, more than double the 22,020,572 in 1942.

Work continued under the National Defense Airport Development Program, for which approximately \$400,000,000 had been appropriated since its inception in 1940. Sites eligible for improvement under the program were those which were certified as essential for national defense and war needs by the Secretaries of Commerce, War and Navy.

During 1943, the number of fields suitable for heavy air transport operations rose from 660 to 940, representing a tenfold increase within four years. All told, there were in this country approximately 3,000 approved airports, an increase of 500 within two years. Planning for the early postwar years the C.A.A. estimated that the country would need 6,000 airports in all categories, approximately twice the number early in 1941. Most of the additional airports would be smaller fields to accommodate private flyers and nonscheduled commercial operations. The estimated cost of such construction would total \$800,000,000, equal to the 1941 investment in airports.

To finance such a program, Charles I. Stanton, Administrator of C.A.A., suggested a Federal Aid program similar to that used in developing our Federal highways system. If the President and the Congress authorized a Federal aid airport program, funds could be apportioned to the States by the C.A.A. upon the basis of some accepted formula. Such a formula, it was suggested, should take account of four factors—the area, population, number of registered aircraft and the existing number of accredited airports in each State. Under this plan, as in the Federal highway system, each State would have to match a specified percentage of its quota of Federal funds. Airport improvements or construction projects within each State would be selected and carried out by the State's aviation agency. Only projects fitting the C.A.A. National Airport Plan would be eligible for Federal aid, of course, and C.A.A. standards for location, layout and construction of the class of airport proposed would have to be met.

The C.A.A. War Training Service gave approximately 250,000 flight courses to Army and Navy cadets in 1943. Part of this vast increase over the 1942 total of 70,000 was attributed to the beginning of C.A.A. 10-hour flight indoctrination courses for all Army cadets during their college training. Previous C.A.A. courses had been at least 35 hours long. Full length elementary courses were given to about 25,000 Navy cadets in 1943. Full length elementary and advanced courses were given to 7,000 Army men being trained as instructors or service pilots.

More than 680 pilots initially trained in Civil Aeronautics Administration contract schools had been decorated for bravery and



#### RADIO CONTROLLED SEADROME CONTACT LIGHTS

The Civil Aeronautics Administration Technical Development Division, working with manufacturers, developed a radio controlled seadrome contact light. Each unit is equipped with a small radio receiver. Whereas it was a manual operation at one time, it is now possible to turn these lights on or off instantly from a control tower on the beach. Using a single frequency, various lighting combinations are made possible through the use of tone modulation.

conspicuous gallantry in action. From inception of the Civilian Pilot Training Act in 1939, to January 1, 1944, more than 9,064,000 hours of flight training were given to student pilots. On that date, 7,564 airplanes were in use in the training program. All told, approximately \$228,000,000 had been appropriated by the Congress to pay for pilot training given under the Civilian Pilot Training Act. Besides preparing many thousands of young men to take their places in the armed services, these funds also served to develop training facilities of permanent value at civilian flying fields and colleges.

During 1943 more than 10,000 new aircraft were inspected at factories by C.A.A. representatives, or were flight-tested, or both. Airmen examined for certificates of competency included more than 18,000 private pilot applicants, 15,000 commercial pilots, 9,500 flight

instructors and 9,000 engine mechanics. The number of pilots holding C.A.A. certificates increased from 110,510 in 1942 to 124,050 in 1943. That increase included both new military pilots who chose to obtain civilian certificates and civilians trained for such essential flying jobs as instructors or members of the Civil Air Patrol.

#### Civil Aeronautics Board

The Civil Aeronautics Board made gradual, steady progress in resolving the complexities in the transition from a peacetime to a war-time character of operation, with the result that it was possible to resume consideration of matters under the Civil Aeronautics Act which circumstances previously demanded be held in abeyance. Much thought was given to the ultimate pattern of air services which would best promote the interest of the United States, and steps were taken to facilitate action on the large number of applications for new service pending before the Board.

Of special significance was the release of 14 additional planes to the domestic air carriers for use in scheduled air transportation. On October 31, 1943, a total of 180 planes was employed in that service. Although this was only 55 per cent of the prewar total, the daily plane-miles scheduled for operation in the continental United States on that date were 310,712, over 84 per cent of the former mileage. Even with greater utilization of equipment it was not possible to accommodate the steadily increasing volume of essential traffic. During June, 1943, nearly 28,000 passengers and more than a million pounds of mail and a like volume of express were refused, or were actually removed from planes because of higher priorities.

The international operations of air carriers continued to increase, despite the fact that a substantial part of their facilities were utilized in contract work in prosecution of the war effort. During the year ended June 30, 1943, these carriers flew slightly more than 21,000,000 revenue-miles in their international operations, an increase of 21 per cent over the previous year and three times the mileage flown in 1938.

"New route" decisions by the Board in the domestic field were rendered in 13 proceedings embracing 53 carrier applications, one certification by the Postmaster General, and three investigations instituted by the Board on its own motion. These decisions added 4,065 route-miles and 17 cities, previously lacking air service, to the domestic passenger system. Two new points and 40 route-miles were added to the mail and property pick-up operations. Under these decisions direct competing air service was provided between San Francisco and Los Angeles. Washington, D. C., was given the benefit of greatly increased air services. Direct service was provided between such important cities as New Orleans-Shreveport-Dallas, San Antonio-Laredo, Amarillo-Denver and Denver-Kansas City; and air service was provided to northeastern Wisconsin.



The initial step in the regulation of air transportation within the Territory of Alaska was taken through the issuance by the Board, with the approval of the President, of certificates to 21 Alaskan carriers. The applications of 13 others who had ceased operations were dismissed. Two applications were denied.

Internationally the Board, upon approval of the President, added 1,075 miles to the certificated American-flag air transport system by issuing a temporary three years certificate for service between New Orleans and Guatemala City, Guatemala, via Merida, Mexico, thus providing a new air transportation gateway between the United States and Central and South America. Additional emergency air service needed between the United States and the Caribbean was provided through temporary short term permits issued by the Board with the approval of the President to five foreign air carriers operating in the Caribbean. Investigation had disclosed that existing certificated carriers did not at that time have sufficient equipment to handle the large volume of wartime traffic.

The effect of the war on civil aviation rendered increasingly important the Board's safety activities. The Board was constantly confronted with the problem of maintaining high safety standards in the face of demands for relaxation to permit essential training and wartime operation activities. Four hundred ninety-seven accidents were investigated by the Board's staff. In its endeavor to make the results of its accident investigation work effective in the prevention of future accidents, the Board's Safety Bureau issued numerous safety bulletins to all classes of pilots and pilot trainees, operators and manufacturers. In addition to its regular duties in this field, the Board cooperated with the Civil Air Patrol and the armed forces, and continued its activities in connection with antisabotage and related measures. Accidents reported, including accidents on the ground and mishaps involving no personal injury and little aircraft damage, increased from 4,493 for the fiscal year 1942 to 5,526 for 1943. One hundred forty-nine involved air carrier aircraft and of these only five, including three which occurred in foreign operations, resulted in fatal injuries. Of the total number, 2.9 per cent resulted in fatal injuries and 2.4 per cent resulted in serious injuries, both of which percentages represented a decrease from the fiscal year 1942. Eleven per cent resulted in the complete destruction of the aircraft involved.

#### Federal Communications Commission

A total of 4,996 authorizations for the use of radio transmitting equipment in the aviation service, including aircraft, aeronautical, aeronautical-fixed airport control, flying schools and flight test radio stations were issued by the Federal Communications Commission during the calendar year 1943. They represented a considerable reduction from the 6,902 authorizations granted by the F.C.C. in 1942.

Almost without exception, commercial aeronautical and aeronautical-fixed radio stations were providing communications service in conjunction with the military forces. Due to the increased activity of the commercial air lines in air cargo operations for the U. S. Army Air Forces, several aeronautical and aeronautical-fixed stations previously closed down were reopened and in addition, new stations were built.

Owing to the lack of Governmental air navigation radio facilities, Aeronautical Radio Inc., radio licensee agency for the majority of U. S. domestic commercial air lines, was authorized to construct and operate several radio marker stations as aids to air navigation. It was anticipated the C.A.A. would take over the operation of these stations or would provide adequate substitute facilities.

#### U. S. Forest Service

Like the Army, the U. S. Forest Service had a parachute corps. In fact the pioneering work of the U. S. Forest Service in developing methods for aerial delivery of men to back country fires was of valuable aid to the Army in organizing its paratroop units. Eighty Forest Service smoke jumpers were trained and in action during the 1943 fire



C.A.A. photo

COMMUNICATIONS CENTER OF THE C.A.A. AT WASHINGTON, D. C.

Showing a battery of teletype machines which connect with other points along the 35,000 miles of Federal Airways.

season. A crew of 10 smoke jumpers operated on the Siskiyou National Forest in Oregon—where in 1942 the Japanese were reported to have tried to fire the forest with incendiary bombs dropped from a plane, the only enemy bombs to land in the United States. Five other smoke jumpers were stationed in central Idaho and the others assigned to North Idaho and Montana. A number of the 1943 smoke jumper crews were conscientious objectors from Civilian Public Service camps, who asked to be allowed to volunteer for this service.

Experimental work in parachuting fire fighters into remote inaccessible areas started in 1934. In 1939, the first actual jumps to test the practicality of landing men in dense timber and rough land were made on the Chelan National Forest in Washington. These tests were successful, and 16 smoke jumpers were equipped and trained for service in the Pacific Northwest and Northern Rockies in 1940. There were 24 men in 1941 and 40 in 1942, with a further doubling in 1943.

On 16 of the 1943 fires extinguished by smoke jumpers for which accurate cost figures were available, the total suppression cost was only one eighth of what the estimated costs would have been if handled by ground crews. This indicated the value of quick delivery by airplane and parachute of trained firemen to back country fires which could be reached by ground crews only after hours or even days on foot. At the request of the Army, the Forest Service smoke jumper crews were maintained on duty after the close of the season of fire danger, for training work and rescue service in the event of airplane crashes or other accidents in remote back country areas. The training center for parachute fire fighters at Seeley Lake near Missoula, Mont., became a center for trainees in aerial rescue. Canadian authorities asked the Forest Service to train a number of representatives from Canadian Pacific Airways and the Aeronautics Observation School at Edmonton, Alberta, as instructors. That school supplied men for rescue work in the Canadian wilds. The Canadian trainees gave a similar course of training to their coworkers upon returning to Canada.

U. S. Coast Guard rescue crews from Alaska also received training at the Forest Service parachute station. After training, they were stationed near wilderness areas along the Alaska coast line for rescue work following airplane crashes or other accidents. U. S. Army medical officers also were assigned to the center for training in parachute work. In addition to woodsmanship and rescue techniques, training at the Forest Service center included special physical exercises to develop facility in traveling mountainous terrain. Practice jumps in full equipment were made from high scaffolds into lifesaver nets to accustom the parachuter to the sudden jerk of the shroud lines and harness; and to train him, also, to fall so as to avoid broken ankles and other physical injuries. That was followed by actual jumps into rough and timbered terrain.

The Forest Products Laboratory at Madison, Wis., continued its

important work on the use of wood in aircraft. To provide data for American and British aircraft designers, the fundamental strength properties of balsa and quipo wood were investigated. The Laboratory prepared the working plans for a world wide study of the effects of climatic conditions and other factors on wings of airplanes over prolonged periods of time. Wood bomber wings were installed at Madison and at the Southwestern Forest Experiment Station in Arizona for technical study of glue joint behavior and effectiveness of protective coatings. Also cooperating in the studies were the British Forest Products Research Laboratories, Canadian Forest Products Laboratories and Australian and Indian Forest research agencies.

The sudden heavy loads to which wood beams in aircraft were subjected in certain maneuvers such as a snap roll or a pullout from a dive were studied by the Forest Products Laboratory with the aid of a motion picture camera which recorded loads and deformations.

A heat-stabilized, compressed wood containing no synthetic resins within the plies was developed that appeared to be adapted to aircraft propeller manufacture. It was named staypak. It could be made from a great variety of species of wood, and its high strength, together with its lack of critical resin, its potentially lower cost and greater ease of gluing were its chief advantages over compreg, an earlier Laboratory development.

Consultive aid was given by Laboratory technicians on problems of waste in the manufacture of aircraft veneer, kiln drying of aircraft stock, strength of wood under various combinations and durations of loading, and many other problems. At the request of the Aeronautical



**RANGER-POWERED FAIRCHILD FORWARDER**

A utility cargo plane produced by Fairchild and designated UC-61K, with 200 h.p. inline, inverted Ranger engine.



### BUILDING THUNDERBOLTS

Republic P-47 Thunderbolt fuselage assembly and final assembly lines.

Board, a revised wood aircraft inspection and fabrication manual was prepared by the Laboratory staff. Two weeks courses of instruction in repair and maintenance of wood aircraft and training courses for inspectors of aircraft wood were given by the Forest Products Laboratory for more than 150 representatives of the Army Air Forces and aircraft manufacturers.

The Forest Service project for logging of spruce in Alaska to augment badly needed supplies of aircraft lumber was well under way. Toward the end of 1943 nearly 30,000,000 board feet of high grade Sitka spruce had been logged, about half of it delivered to State of Washington mills and the remainder either assembled in booms for rafting or felled and bucked or yarded into cold decks in the woods. The logs were towed in huge rafts 900 miles to the Puget Sound area.

The Forest Service and cooperating conservation agencies continued their campaign for public cooperation in the prevention of forest fires, and intensified fire protection work to safeguard vital resources and facilities. About 185,000 civilians enrolled in a volunteer Forest Fire Fighters Service, organized under the auspices of the Office of Civilian Defense, to aid Federal and State forestry agencies suffering from loss of regular fire fighting manpower. Units of the Civil Air Patrol aided forest protection agencies in several areas. This fire protection work was of special value to aviation because heavy smoke palls caused by forest fires were severe handicaps to flying and flight training.

### Munitions Control Unit

The Munitions Control Unit, a part of the Division of Supply and Resources of the Department of State, continued to administer the registration and licensing provisions of Public Resolution No. 54 ap-



proved November 4, 1939. Section 12 of this Act required that all persons engaged in the business of manufacturing, exporting, or importing any of the articles or materials enumerated by Presidential proclamation shall register with the Secretary of State. The Presidential proclamation which was in effect during 1943 was issued on April 9, 1942. The articles listed in this proclamation included aircraft and gliders of all kinds, aircraft engines, propellers, essential parts such as wings, hulls, fuselages, undercarriage units, tail units and a number of items of aircraft armament, including aircraft guns, and cannon, gun turrets and aircraft armor plate. Under the law it continued to be unlawful for any person to export or import any of

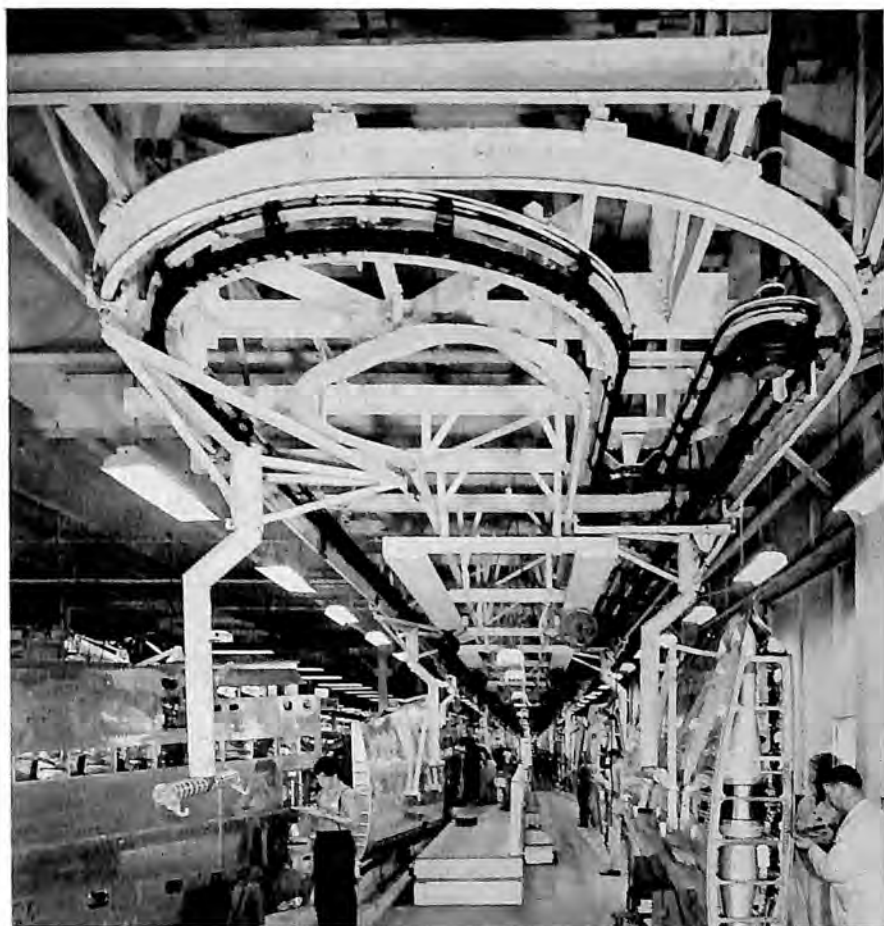

#### NORTH AMERICAN'S CONVEYOR LINE

Conveyor line for outer wing tips at the California Division of North American Aviation. Continuously-moving conveyor lines were installed throughout most of the plant for the manufacture of B-25 Mitchell bombers and P-51 Mustang fighters.



#### MARTIN BOMBER ASSEMBLY

U. S. Army Air Forces B-26 Marauder twin-engine bombers nearing completion at the plant of The Glenn L. Martin Company near Baltimore.

the articles listed in the President's proclamation without first having submitted to the Secretary of State the name of the purchaser and the terms of sale, and having obtained a license therefor. Lend-Lease shipments, however, remained exceptions to these regulations. Licenses were not issued in any case in which it was determined that the proposed shipment would be contrary to the interests of the war effort. Two special unlimited licenses which had been issued to the British Ministry of Supply Mission in 1942 covering certain exigencies in the international munitions traffic remained in force during 1943. On January 15, 1943, an unlimited license covering shipments to and from Canada was issued to all those importers and exporters registered with the Department of State. Matters pertaining to priorities on aircraft, aircraft parts and accessories also were handled by the Unit. In enforcing the provisions of Sections 1 and 2 of Title 1 of the Espionage Act approved June 15, 1917, the Munitions Control Unit handled all applications for permission to manufacture aircraft or aircraft equipment abroad.

#### National Advisory Committee for Aeronautics

The National Advisory Committee for Aeronautics was one of the important agencies of the Federal Government which involved research and development in the field of aeronautics. Practically all the results of its work were treated as secret military information, availa-

ble only to Army and Navy and military contractors in the aircraft industry.

The N.A.C.A. was established by law in 1915 with the extremely modest appropriation of \$5,000 a year for five years "or so much thereof as may be necessary," and was charged with supervising and directing the scientific study of the problems of flight. It was authorized to direct and conduct research and experiment in aeronautics. The N.A.C.A. had three major research stations in 1944—the Langley Memorial Aeronautical Laboratory at Langley Field, Va., the Ames Aeronautical Laboratory of Moffett Field, Calif., and the Aircraft Engine Research Laboratory at Cleveland, O. They were worth 70 million dollars in plant value. The budget for operating expenses for the fiscal year 1944 was \$20,000,000 and for the following year \$23,000,000. The staff on March 1, 1944, totaled 5,000 employees, with authority to increase to 6,500 during the fiscal year 1945.

The National Advisory Committee for Aeronautics included 15 members appointed by the President and serving without compensation. The membership included the heads of the Army and Navy air organizations. Under the main Committee there were five major and 18 subordinate technical committees, the membership being carefully selected and revised annually with the object of marshalling



#### LOCKHEED LIGHTNINGS ON MECHANIZED ASSEMBLY

Moving slowly but continuously, three mechanized conveyor lines more than doubled the former daily output of Lightning fighters at the Lockheed plant at Burbank, Calif.

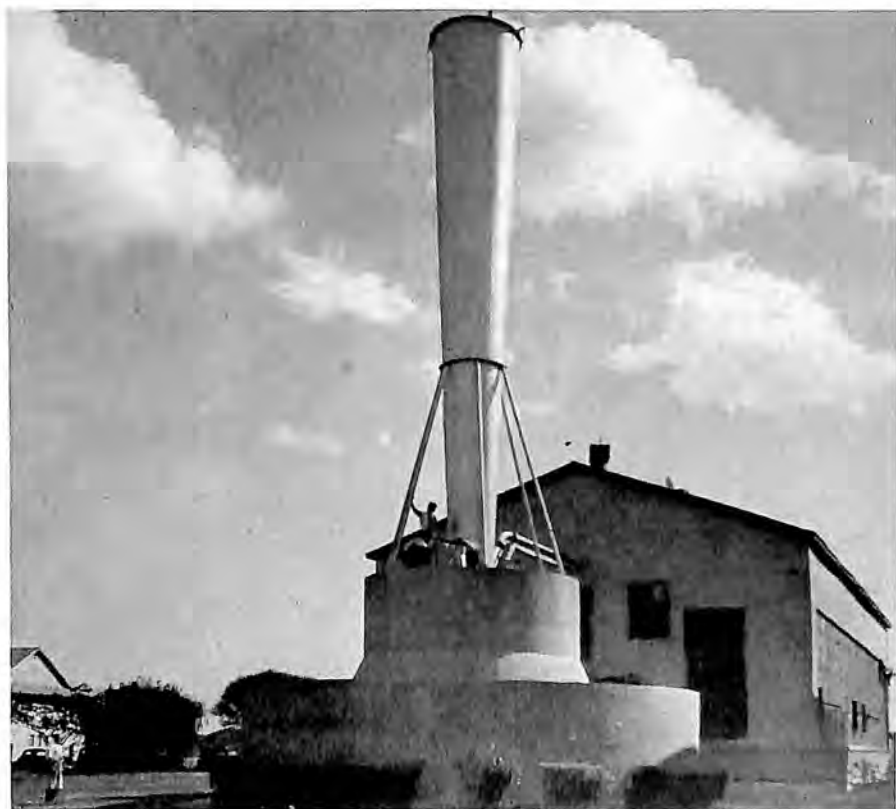

N. A. C. A. photo

#### N. A. C. A. HIGH SPEED TUNNEL

The smokestack-like structure is the exit diffuser of the National Advisory Committee for Aeronautics 24-inch high-speed wind tunnel at Langley Field, Va. Through the use of compressed air released from a large steel tank, air is induced to flow through the tunnel test section at speeds greater than 700 miles per hour.

effectively the talent of America in the preparation of research programs and in guiding the course of research and experimentation in aeronautical development.

The N.A.C.A. was farsighted in anticipating the war. It started in 1937 to prepare plans for expansion in order to meet the needs of the Army and Navy for more rapid technical development in order to provide aircraft of maximum military effectiveness.

Control of the air became the most important of military objectives. In order to achieve control of the air it was essential to have aircraft of superior performance and to have more of them than the enemy. The demands of war imposed upon the Army and Navy the obligation to insist upon continuous improvement. The result was urgent requests for special studies and investigations by the N.A.C.A. on every new type of airplane proposed for production, and also the prompt study of difficulties encountered in service by aircraft at their

highest speeds, in both violent maneuvers and terminal velocity dives.

In order to meet the critical military objectives set for it by the War and Navy Departments, the N.A.C.A. was expanding research facilities at each of its three laboratories and was working on a two and three shift basis as extensively as practicable. No time was lost in getting the results into the hands of the military services and the industry, and they were promptly incorporated in designs of aircraft, including those designs already in production.

#### The National Inventors Council

The National Inventors Council was created by the Secretary of Commerce in August, 1940. The Council commenced operations early in October of that year, following the selection of Council Members and the organization of a service staff. Council members comprised outstanding American inventors, scientists and industrialists having wide experience in the development and utilization of inventions. Primary duties were: (1) Encouraging the public to submit inventions or inventive ideas having potential value in the war effort; (2) Prompt evaluation of these inventions by a staff of engineers and by a system of technical committees so that useful ideas might be placed promptly in the hands of the military and naval bureaus.



U. S. A. A. F. photo

#### LAYING A SMOKE SCREEN

The Army Air Forces helped protect our tanks maneuvering for an attack.





U. S. Signal Corps photo

#### TRAINING AIRBORNE INFANTRY

Paratroopers and other troops with artillery practise for assaults behind the enemy front lines.

By March 1, 1944, more than 200,000 inventions and inventive suggestions had been received and examined by the technical staff. They came from all parts of the world but mostly from the United States. By direction of the Army Chief of Staff, all inventions from officers and men in the Services were sent through channels to the Council for primary examination. Inventions from Navy personnel likewise were sent to the Council.

Inventions or suggestions thought to be of value in the war effort, after review by the Council, were forwarded to the Army or Navy, or both, for their consideration and ultimate adoption, if they were found acceptable. The appropriate branches of the Army or bureaus of the Navy then dealt directly with the inventor in arranging for use of his invention. The Council itself did not consider the question of compensation or contracts in respect to the use of an invention or inventive suggestion.

Of the 200,000 cases examined by March 1, 1944, 30 per cent were in the aeronautic classification. They embraced suggestions and inventions relating to all types of aircraft and aircraft parts, heavier and lighter than air, power plants and accessories, instruments, armor and armament, airport and airway equipment and facilities and flying equipment such as clothing. As might be expected, only a relatively small percentage of the total merited further study or trial. But while the percentage was small, the total number accepted was important. While war conditions prevented revelation of the details, the important inventions concerned improvements in the size and performance of

engines and power plant accessories; steam and jet propulsion power plants; improved and new types of airfoils, control surfaces, new instruments for both aviation and combat use; instruments and instrument board simplification; aviation aids, including portable blind-landing apparatus; all types of armament, both guns and bombs; airport equipment, both fixed and portable and, of course, new types of combat and transport planes.

Primary examination by the Council relieved Army and Navy officers from this onerous duty, in respect to thousands of useless suggestions. The system of processing promising inventions assured their being given ample consideration by the Services. Several were found acceptable and many were in use in the combat areas early in 1944.

#### U. S. Public Health Service

The United States Public Health Service constantly was concerned with aircraft in connection with its administration of quarantine laws to prevent the introduction into the United States of dangerous disease and disease carriers, both human and insect. Extension of airplane traffic to all parts of the world increased to a great degree the danger of the introduction into the United States of exotic insect vectors of



U. S. Signal Corps photo

#### GENERAL CLARK LANDS IN NAPLES STREET

General Mark Clark climbs out of his Piper Cub which has just landed him on one of Naples's streets in the heart of the city to attend a General Staff meeting.



U. S. A. A. F. photo

#### AFTER OUR WARNEMUNDE ATTACK

This is an interpretation report made after the attack by our Army Air Forces on the Focke-Wulf 190 factories at Warnemunde, Germany, on July 28, 1943. The numbers show the buildings hit, circles show bomb craters, dotted lines heavy concentrations.

disease and required much additional quarantine service of the most expert type at airports of entry in this country. Efforts were directed especially to preventing the introduction of *Aedes aegypti* mosquitoes from areas in which yellow fever was endemic or epidemic, and at excluding the *Anopheles gambiae*, a native of Africa and a highly efficient carrier of malaria.

The fundamental principles of aircraft quarantine were in most respects comparable to those governing maritime quarantine, except for the added health hazard which air transport introduced by bringing persons into the country before the incubation period of disease to which they might have been exposed had elapsed. Quarantine meas-

ures included medical inspection of airplane passengers and crews, supplemented by medical surveillance of persons arriving from foreign areas where a quarantinable disease was present, until the incubation period had passed.

As the speed and volume of air travel increased, it was obvious that greater vigilance on the part of quarantine officers became necessary for the protection of infectible ports and areas in the United States.

All commercial aircraft arriving at United States airports from ports located on the African continent between 16 degrees north and 12 degrees south latitude, or from the South American continent between 13 degrees north and 30 degrees south latitude, were required to be disinfected without preliminary inspection, immediately after



#### GENERAL EISENHOWER AND HIS CUB

The Allied Commander-in-Chief, General Dwight D. Eisenhower, on his last inspection tour of the Italian front before leaving for his new command in England. His personal plane was a Piper Cub.

disembarkation of passengers and crew and before baggage, merchandise and mail were discharged. The Surgeon General could designate any foreign area as dangerous because of the presence of exotic insect vectors of disease. Planes arriving from areas so designated were required to be disinfected prior to the discharge of passengers and cargo. In addition, operators of commercial aircraft were encouraged to continue the practice of spraying aircraft in flight as a means of safeguarding passengers and flight personnel.

In order to meet wartime military requirements, the Surgeon General was given discretionary authority, when requested by competent military officials, to designate the senior medical officer of an Army or Navy air base to serve as quarantine officer for the inspection and treatment of military aircraft carrying military personnel and proceeding on confidential missions.

At the Miami Quarantine Station a standard procedure for the disinsectization of aircraft was developed which reduced to a marked degree the exposure time required to kill mosquitoes. This procedure relieved both military and commercial aircraft of much of the delay incident to procedure previously followed.

Owing to the increased volume of air traffic into the capital of the United States from foreign ports, a quarantine station was established at the Washington National Airport during 1943.

An Interdepartmental Quarantine Commission was appointed by the Federal Security Agency, and the War and Navy Departments in 1943. The purpose of the Commission, composed of one medical officer from the U. S. Public Health Service, the Army and the Navy, was to study existing quarantine laws and enforcement procedures and to recommend such changes as might be necessary to protect the United States and our armed forces in other countries against the introduction of quarantinable and other tropical diseases.

#### U. S. Weather Bureau

Expansion of the national weather service continued during 1943 with the same basic objectives as in 1942, namely improved quality and distribution of weather information for the benefit of war production and military operations, with special attention to civil and military aviation. An especially important service in this latter respect was accomplished in the organization of the U. S. Weather Bureau's Flight Advisory Weather Service in direct association with the Airway Traffic Control of the Civil Aeronautics Administration. Meteorologists schooled in the interpretation of weather data were assigned to the 23 established Airway Traffic Control Centers, with airway forecasters on duty in or immediately adjacent to the A.T.C. offices, to provide meteorological information bearing upon the control of planes in flight.

Congressional approval for installation of ceilometers at 112 addi-



tional airport stations of the Weather Bureau opened the way for a long needed aid in the protection of aviation. The instrument provided accurate measurements of ceiling in daylight as well as at night. Procurement difficulties delayed the installations, but considerable progress was expected during 1944.

The use of ceiling classification letters to indicate the method of obtaining ceiling values was initiated to improve the definitive value of these reports. Visibility observations from control towers were instituted at a large number of stations. During periods of low visibility, the observers at these stations served continuously in the towers in order to provide explicit and fully dependable visibility data at all times. To meet increasing military demands for upper air information, 17 additional radiosonde stations, including three in Mexico, and seven additional pilot balloon stations, including one in Alaska, were established.

In the forecasting service, several adjustments were made to meet

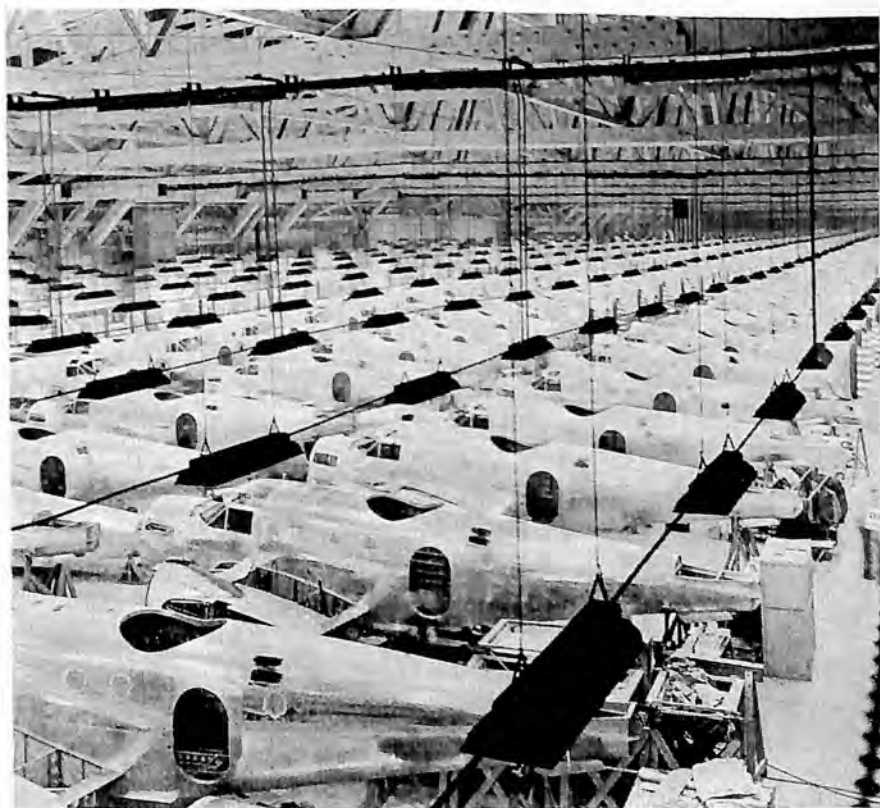

#### BEECHCRAFT TRAINER PRODUCTION

Advanced trainers for the Army Air Forces in final assembly at the plant of Beech Aircraft Corporation, Wichita, Kans.

shifts of maximum demand and accomplish a higher overall efficiency in this phase of Weather Bureau operations. In addition, a considerable number of new weather reporting stations were established and service expanded at others (notably in the area west of the Continental Divide) to meet expanded requirements of military aviation.

As a result of the heavy increase in Civil Aeronautics Administration communications work, it was necessary for the Weather Bureau to take over the operation of a number of weather reporting and teletype stations formerly operated by the C.A.A. The transfer of 27 such stations from the C.A.A. to the Weather Bureau was completed, including the absorption by the Weather Bureau of related communications work. A particularly welcome adjustment with respect to aviation was the lifting of censorship of meteorological information sufficiently to permit broadcast of weather forecasts and hourly airway weather reports in plain English from all C.A.A. voice facility stations.



U. S. A. A. F. photo

**"WHEN THE RAIN ROARS ON YOUR ROOF"**

Pilot and bombardier carrying the bombsight aboard an AT-11 Beechcraft bombing trainer warmed up for take-off on a night training mission in bad weather.

## CHAPTER IX

### AERONAUTICAL ORGANIZATIONS

**D**EVELOPMENT of American air power to the fullest possible extent was brought about by the close cooperation between the Army and Navy air forces and the important civilian organizations which labored for many years to build up our aeronautical engineering and other branches of aviation. Their wartime activities were of the highest importance in maintaining our supremacy in the air. The work of the new organizations, such as the Aircraft War Production Councils, was equally important in maintaining the aircraft plants at the peak of production.

#### Aeronautical Chamber of Commerce of America

The Aeronautical Chamber of Commerce of America, after 23 years as the trade association of the aircraft manufacturing industry, changed its activities and the organization of its staff to meet current needs and take care of many new problems arising from the war. James P. Murray, vice president of Boeing Aircraft Company, continuing as president of the Chamber, said in his annual report, "The past nine months have convinced me more and more of the necessity of a strong trade association to represent the industry, and I commend the Chamber to you for your active support." Immediate supervision of the staff was taken over by Harrison Brand, Jr. as General Manager upon the resignation of Irving H. Taylor, who had joined the Douglas Aircraft Company. The technical department, working under the guidance of the airplane technical committee and the engine technical committee, directed its efforts largely towards coordination of the industry's cooperative technical activities with those of the military Services. This work influenced the improvement of the technical content of the specifications and standards administered by the Services in most of the contracts entered into with the industry. Resulting improvement in basic documents reduced, and sometimes eliminated, discussion and argument over details and consequently saved time, money and energy for all concerned.

The technical committees functioned largely through subcommittees on specialized subjects such as powerplant installation, structures, detail design, flight test and aerodynamics, plastics, standards, specifications and preservation. The most active of the subcommittees was the National Aircraft Standards Committee, formerly independent but for two years an integral part of the Chamber's technical department. Standards on basic materials established as a result of its

activities substantially alleviated the materials supply problem. An equally important activity was the coordination of industry recommendations on existing or proposed Army-Navy aeronautical standards and specifications, over 100 of which were considered in 1943. The technical department also cooperated with the engineering advisory committees of the War Production Councils and foreign aeronautical agencies, including those of Great Britain, Canada, Australia and China.

While engine standards are not the direct responsibility of the engine technical committee it recommended improvements in many existing Government procurement specifications. Acceptance of these recommendations eliminated the necessity for many deviations.

The Aeronautical Chamber's traffic department completed its first full year, functioning under the guidance of eastern, central and western regional committees, each of which held several meetings, with a joint meeting of all three in October, 1943. Activities of the traffic department were devoted to securing the lowest possible rates for shipments, the use of uniform classifications and to studies of shipment consolidations, insurance, warehousing and losses in transit, to the end that the cost of moving materials and products were reduced to a minimum. Cooperation with the Army, Navy and Office of Price Administration, appearance before regulatory bodies, and the study of pending or needed legislation were required. The volume of work was indicated by the 150 problems dealing with such matters as rates, packing, marking, export regulations, legislation, bills of lading, railway express service, air priorities, O.D.T. truck regulations and others which came before the various committee meetings, and the 211 bulletins sent out by the traffic department, the work of which produced substantial savings.

The information department of the Chamber kept members advised on a variety of subjects formerly the functions of several departments. It maintained and added to the statistical files and answered inquiries from members, Government agencies, writers, press, radio and the public. Nearly 250 bulletins were issued in 1943, dealing with legislation, labor, selective service, contract termination, renegotiation, Comptroller General's decisions, excess profits taxes, material supply, price regulation and priorities.

The economic development department working under the guidance of the economic development committee and the Council developed a plan for the consideration and treatment of a variety of subjects, some of more or less immediate importance and others looking to the more distant future. Three groups of subcommittees worked out full committee resolutions, resolutions covering further study of the disposal of surplus military aircraft, the future use or disposition of defense plant and equipment, preparation for more effective consideration of legislation and administrative regulations, publication of sta-

tistics and the development of future domestic and foreign trade. Specific recommendations as to principles that should govern the renegotiation of war contracts and their termination were aimed at securing a degree of assurance that the industry would be left in a condition to carry on after the war. The special needs of the manufacturers and

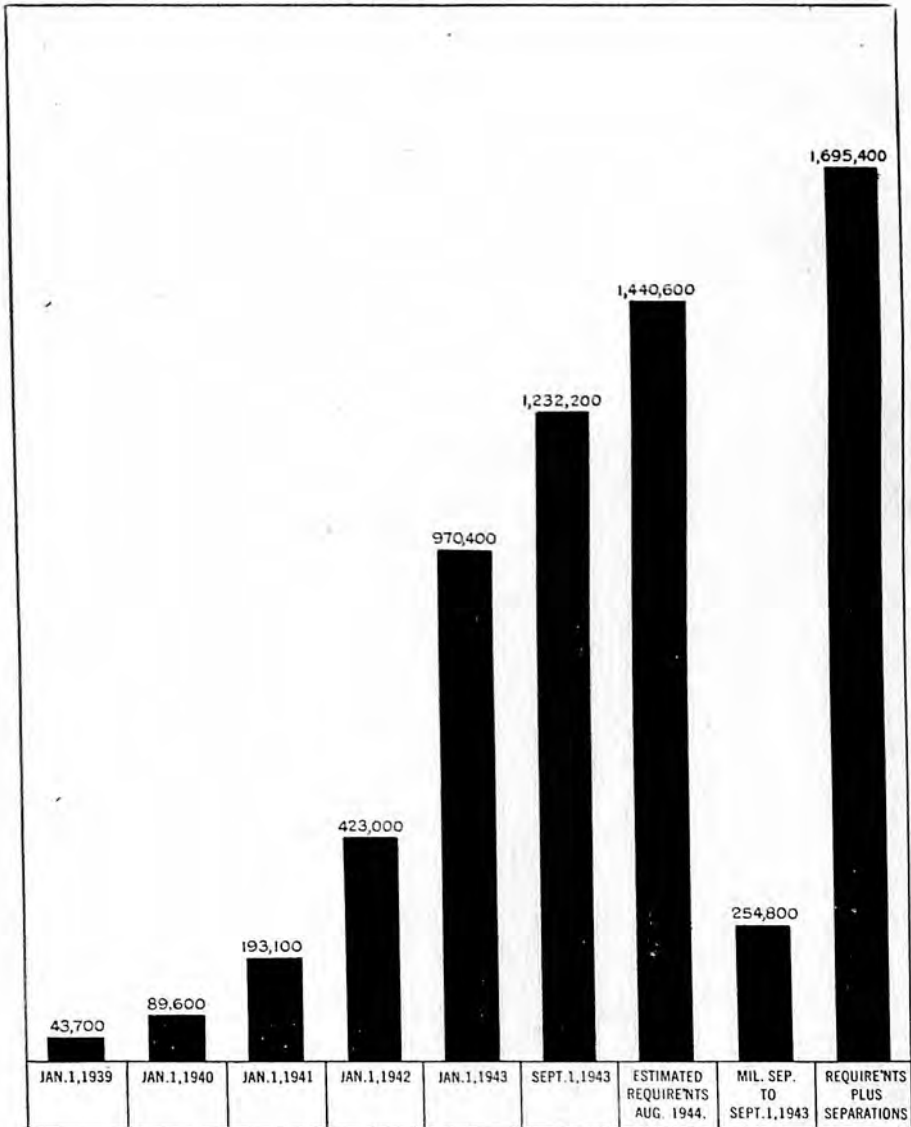

EMPLOYEES IN THE AIRCRAFT INDUSTRY

Estimates prepared by the Aeronautical Chamber of Commerce of America showing status of employment by manufacturers (not including subcontractors) of aircraft, engines and propellers in the United States.



users of personal airplanes were recognized. An investigation of the possibility of feeder air routes was completed.

A new department was established on January 1, 1944, to handle the problems of the manufacturers of personal airplanes. In line with recommendations for an economic development program, new departments of the Chamber were being established, including a legislative department and a research and statistics department to provide authoritative data on aviation and to conduct research studies.

#### Aircraft Owners and Pilots Association

The Aircraft Owners and Pilots Association worked to make non-scheduled flying more useful, safer, less expensive and more fun. A.O.P.A. aimed to be to the pilot what auto clubs were to motorists; especially when motoring was new. It was a non-profit pilots' organization, and membership was open to pilots only. During 1943, A.O.P.A. rendered many services to member pilots. Government officials were contacted to solve individual problems sent in by members. The pilot advisory service assisted members in such matters as war-time regulations, airport facilities, pilot, aircraft, and radio licenses, employment, sale and purchase of aircraft, tow-in and repair service for aircraft after forced landings or crack-ups; legal advice specializing in aviation matters; a reduced rate on Driv-Ur-Self automobiles throughout the country. The Association conducted a legislative branch for the purpose of reflecting pilots' viewpoints on proposed regulations; assisted in removing and preventing the erection of airport obstructions; offered special privileges to its membership at A.O.P.A.-designated hotels; designed plans for Airhavens (attractive homes built around landing fields) and continued its fight for simplified Federal regulations; fought successfully for the enactment of regulations beneficial to civil aviation and for the elimination of rules considered detrimental.

The Association's program also included, when conditions should permit, arranging of special flights; operation of a travel bureau to assist pilots wanting to fly abroad; publication of an airport directory and radio guide for cross-country flights, including the rating of airport equipment and services; testing and rating of aircraft and accessories; advocacy of minimum insurance rates for pilots and planes and the quicker action on Approved Type Certificates for newly developed aircraft and a vigorous campaign for more landing strips, airports and seaplane bases located close to city centers.

#### Aircraft War Production Council

In April, 1943, the national Aircraft War Production Council was formed, with headquarters in Washington. Its purpose was to implement the successful work being carried out by the regional East and West Coast Councils in their efforts to bring about airplane pro-

duction increases through teamwork and exchange of development and manufacturing experience. Frank Ford Russell was appointed as general manager of the National Council and Richard C. Palmer was made secretary. The board of directors consisted of six company

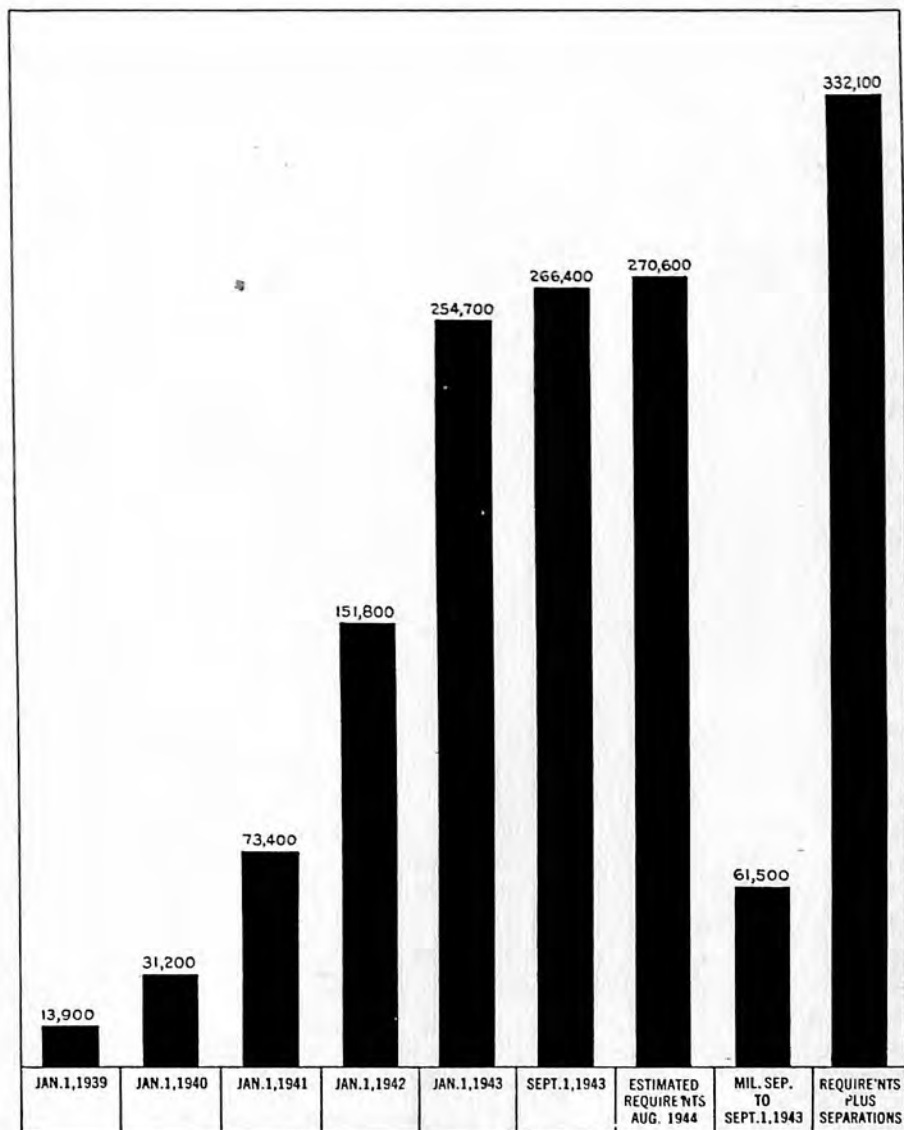

#### AIRCRAFT EMPLOYEES IN CALIFORNIA

Estimates prepared by the Aeronautical Chamber of Commerce of America showing status of employment by manufacturers (not including subcontractors) of aircraft, engines and propellers in California.

presidents, three representing the East Coast and three representing the West Coast sections of the industry. The National Aircraft War Production Council concentrated on problems affecting the industry which were national in scope, acting as intermediary between regional Council members and the Government agencies. Close liaison was established with the Aircraft Production Board, Army, Navy and other Federal departments concerned with aircraft production.

Activities undertaken by the National Council included conferences between industry and Army, Navy and W.P.B. on materials allocation which resulted in a smoother application of the controlled materials plan, and was of great assistance in lessening materials shortages affecting the industry, assistance in forming policies on materials distribution, cooperation with the Bureau of the Budget in the establishment of an aircraft advisory committee which concentrated on simplification and improvement of forms required from prime contractors. The National Council assisted the Aircraft Resources Control Office in a survey of non-controlled materials, secured changes in bills of materials requirements, sponsored and secured changes in the C.M.P. timetable which permitted advance allotments and better production planning; and conducted an extensive investigation into the disposal of surplus materials, with proposals for solution presented to W.P.B. and the air Services.

The National Council also initiated conferences on manpower, child care, plant service bureaus, gas and tire distribution problems, 10-hour shifts, wage incentives, reemployment of released war veterans, housing, industrial feeding; and supplied Washington informational services.

Labor turnover, a matter of increasing seriousness in industry's efforts to maintain and increase production schedules, became a part of the larger manpower problem. The National Council worked with the regional Councils and with the Government agencies concerned to bring about actions which would alleviate this situation. Conferences were held with Bernard M. Baruch and Justice James Byrnes, director of the Office of War Mobilization for the purpose of determining the establishment and operation of the West Coast manpower program. Similar meetings with officials of the War Manpower Commission and the War Production Board were of assistance in securing progressive action.

Meanwhile, the regional Councils performed their own important responsibilities in extending the policy of industrial teamwork for increased war production. Their success was reflected in the record numbers and high performance of planes built during 1943.

Members of the Aircraft War Production Council, West Coast, included Boeing Aircraft Company, Consolidated Vultee Aircraft Corporation, Douglas Aircraft Company, Lockheed Aircraft Corporation, North American Aviation, Northrop Aircraft, and Ryan.

Aeronautical Company. Operations were carried on through five principal committees dealing with production expediting, engineering, industrial relations, public relations and accounting; eight sections concerned with employee services, Government reports, information,

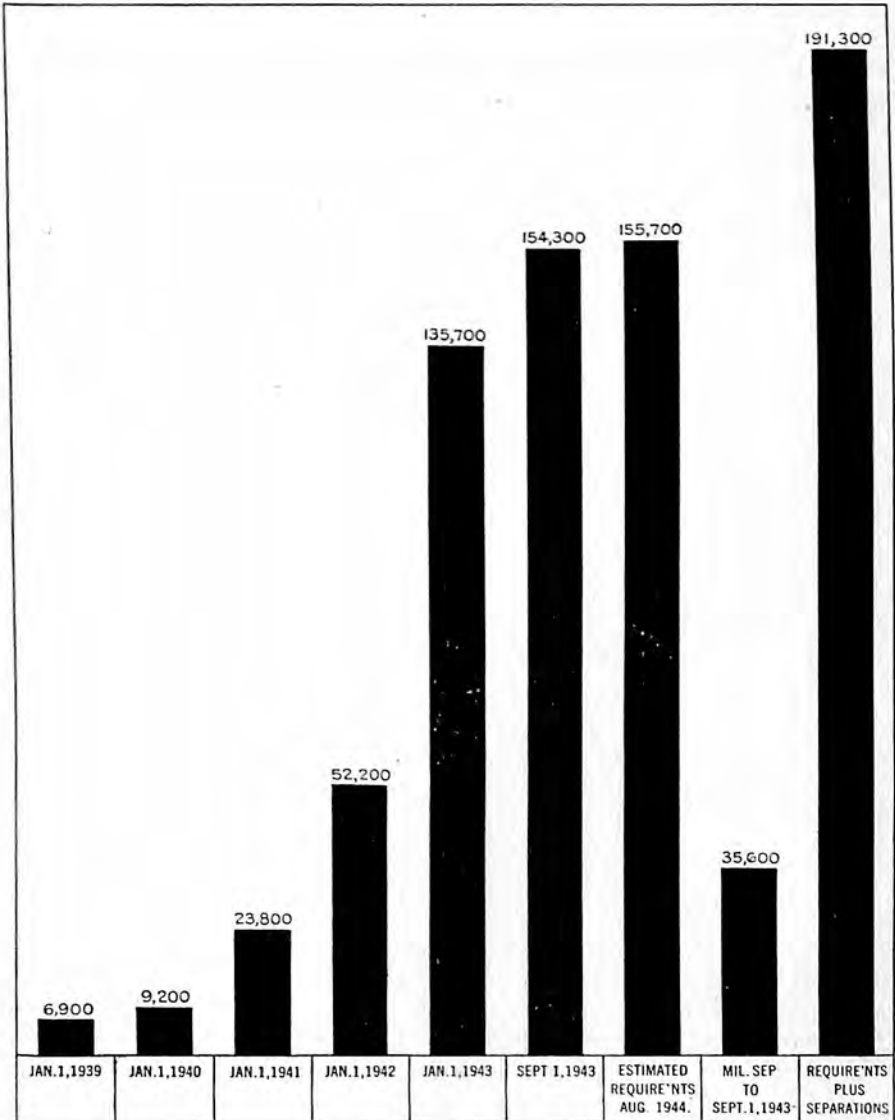

AIRCRAFT EMPLOYEES IN NEW YORK

Estimates prepared by the Aeronautical Chamber of Commerce of America showing status of employment by manufacturers (not including subcontractors) of aircraft, engines and propellers in New York.

materiel, outside production, plant production, recruitment and training; 22 panels on child care, conservation, engineering manpower, field service, Government specifications on technical data, housing, industrial medicine, industrial safety, inspection, librarians, material substitution, methods improvement, parts fabrication, patent officers, plant protection, selective service, spare parts, testing and research, tooling, transportation, turnover and absenteeism and visual aids; and nine project groups dealing with ANC-5, casting inspection, rivet strength, integral fuel tank sealing, labor utilization teams, manpower audit, temperature effects, tooling standards and wage incentives.

In 1943, the Pacific Coast aircraft industry's main plants produced 23,598 airframe units, weighing 274,078,000 pounds excluding spares, and valued at \$2,076,552,000. Drawing on the top planning, engineering and production know-how facilities of the parent concerns, branch plants turned out many thousands more warplanes from assembly lines in Arizona, Florida, Illinois, Indiana, Kansas, Kentucky, Louisiana, Michigan, Missouri, North Carolina, Oklahoma, Pennsylvania, Tennessee and Texas. The West Coast companies produced a majority of the nation's output of heavy bombers.

To increase production still further, a new labor utilization survey of West Coast plants was undertaken in cooperation with the Army, the Navy and the War Manpower Commission. Faced with the necessity of producing more and heavier airplanes, the member companies were determined to leave no fields unexplored in their efforts to achieve maximum use of available labor. Work simplification, labor pooling systems, job reclassification and other production streamlining procedures were examined in efforts to reveal where greater efficiency might be attained. Steadily accelerating tempo of the war in the Pacific theater, which placed additional strains on West Coast production facilities, emphasized the need for such action. The labor pooling or labor dispatch system, a West Coast development, had its inception in the Douglas plant at Santa Monica, Calif., on January 11, 1943. Action was taken during the year to spread the procedure through the West Coast industry. If material shortages, schedule revision, changes in specifications or other such causes should make workers temporarily idle in one section of a plant, the labor dispatch system routed or loaned those employees to departments where they were needed. More than 1,000,000 manhours were salvaged or more efficiently utilized through labor dispatch at that one Douglas plant.

At the beginning of 1944, while manpower availability remained the major limiting factor in warplane production, the Council companies were able to report reductions in personnel turnover, and take up such pressing problems as a newly aggravated transportation situation, the possibility of new manpower shortages, studies of wage incentives and production streamlining procedures.

A 1943 development saw disabled veterans of the global war added



to the aircraft industry's labor force by hundreds; and early in 1944, it became apparent they would join the production lines in increasing numbers. Having anticipated that trend, Council companies developed programs offering returning service men every opportunity to

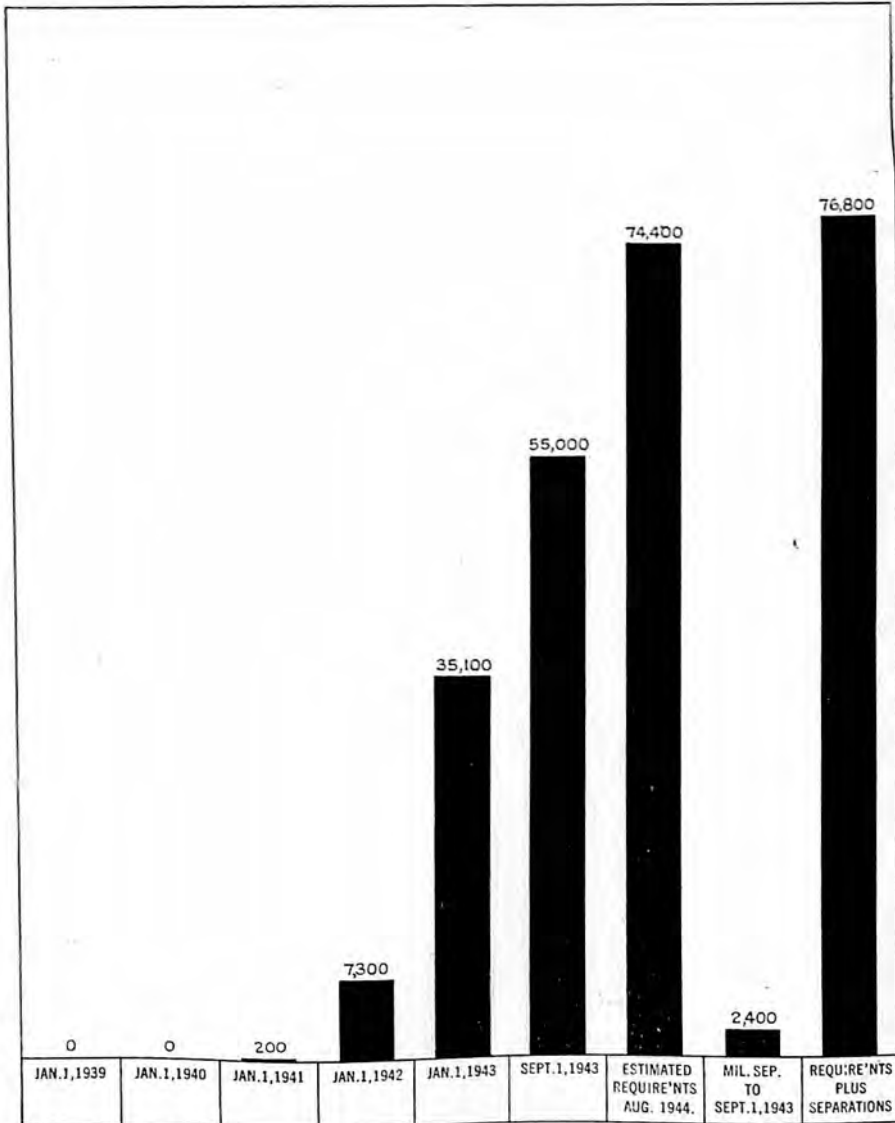

#### AIRCRAFT EMPLOYEES IN TEXAS

Estimates prepared by the Aeronautical Chamber of Commerce of America showing status of employment by manufacturers (not including subcontractors) of aircraft, engines and propellers in Texas.

reintegrate themselves into civilian life. Skilled workers readily found production jobs. Training methods were instituted for those who required instruction and rehabilitation.

An outstanding development of 1943 was a major increase in employment of women. The West Coast industry, by work simplification and related devices, was able to achieve a ratio of 44 per cent of women to the total working force in January, 1944. This record was notable in view of the fact that Great Britain found it impractical to employ more than 40 per cent women.

Child care became important to West Coast aircraft companies as the number of women workers increased. A panel of specialists prepared for the Council a comprehensive survey which was helpful in stimulating expansion of the Los Angeles community child care program and securing additional centers for the convenience of working mothers.

Council specialists made a comprehensive study of labor utilization in West Coast aircraft plants and a committee of executives undertook a continuing survey of labor utilization efficiency. An early report, issued September 30, 1943, provided background for a production expediting committee of manufacturing vice presidents. This committee completed a manpower audit which was accepted by the Government as presenting sound manpower requirements, making an approach to the problem so reliable that it was used as a gauge by several Government agencies. Labor utilization teams examined each company's accomplishments with the object of spreading valuable procedures to all plants.

The Council, in all phases of its work, had a close working relationship with many Government agencies. Proposed Government directives frequently were submitted, through the Council, to the aircraft manufacturers for comment and suggestions. This procedure was especially helpful in the fields of Government reports, spare parts, cadmium plating and statistical control. The Council's Government reports section cooperated with the Bureau of the Budget through its advisory committee on government questionnaires. Through an aircraft subcommittee, views of the industry on proposed and revised forms were presented to the Budget Bureau prior to approval of Government forms and questionnaires.

The problem of training aircraft industry personnel shifted from the instruction of inexperienced individuals to increasing the efficiency of those already on the job. Through November, 1943, 671,037 employees of Council companies had taken one or more types of training. Included were 426,500 who completed preemployment, prefactory, upgrading or supplementary vocational training; 52,800 who completed college grade training in those categories; 81,100 given supervisory training in foremanship. In addition, 50,800 man courses were given in various types of plant defense training; more than 44,000 man

courses in customer training to acquaint military personnel with the use of company products, and miscellaneous courses were completed by 12,623 persons.

Recognizing that transportation would be one of its major prob-

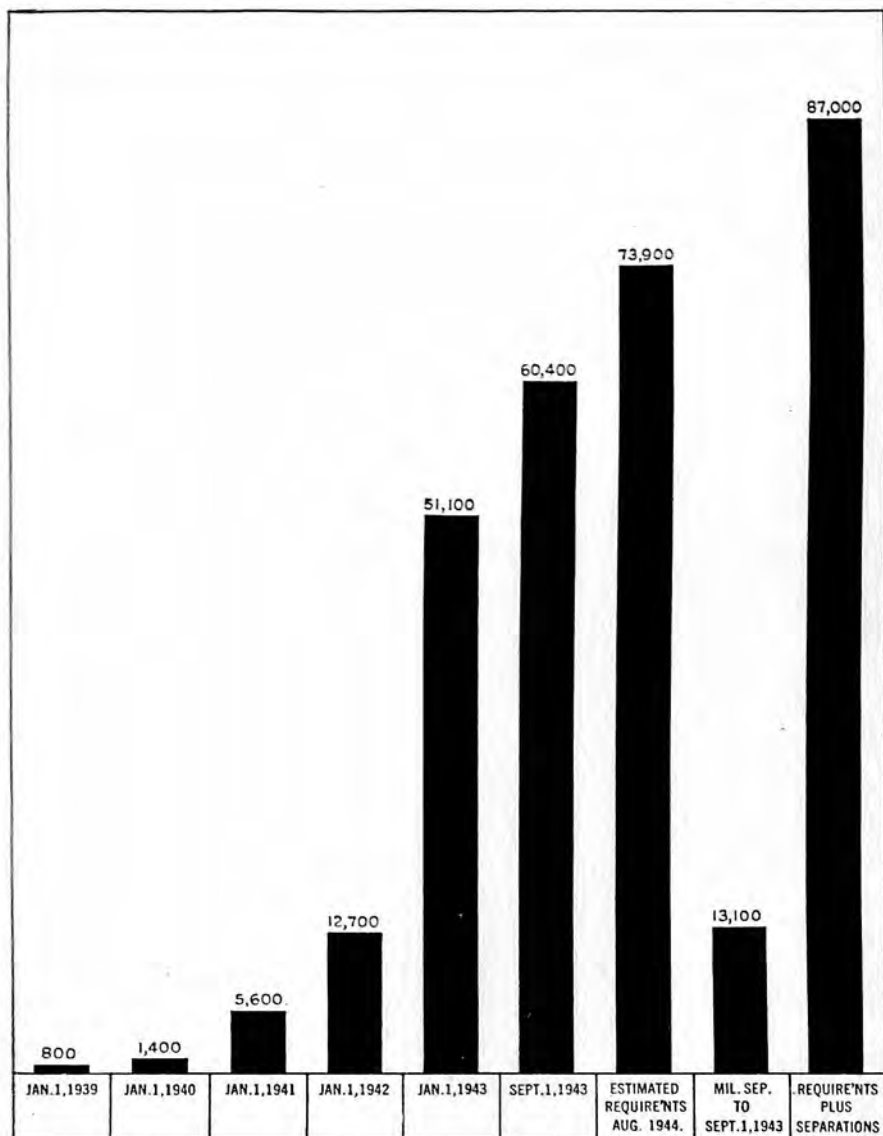

#### AIRCRAFT EMPLOYEES IN KANSAS

Estimates prepared by the Aeronautical Chamber of Commerce of America showing status of employment by manufacturers (not including subcontractors) of aircraft, engines and propellers in Kansas.

lems in 1944, as it was in 1942 and 1943, the Council kept Federal authorities advised on developments in this field, making a survey of the gasoline shortage and another on the need for making tires and repair parts available for war labor automobiles. A detailed transportation report on West Coast conditions was presented to the Government in January, 1944. Plant site administration for distribution of mileage rationing books to employees was brought about by Council effort.

The West Coast aircraft industry's 1943 record of a 66.93 per cent increase over 1942 in weight of planes produced, with a personnel increase of less than one per cent was due in large part to new and improved production methods developed by industrial engineers. These top men, through the Council's methods improvement panel, prepared comprehensive reports dealing with industry practices and developments in riveting, welding and processing. In April, 1943, the Council began monthly publication of "Warplane Production", which listed production shortcuts developed by member companies and made available to all Government recognized aircraft manufacturers. Member companies exchanged, up to the end of 1943, approximately 8,664 engineering reports. These interchanges, made available to all aircraft plants engaged in the war effort, represented an estimated saving of more than 765,000 man hours, or 100,215 man days, and contributed greatly to war production through elimination of duplicated effort.

Materiel exchanges between member and nonmember companies of the Council broke innumerable bottlenecks in the production of warplanes. More than 30,000 exchanges were made during 1943. A study by the Council, in cooperation with military and other Government agencies, resulted in many revisions in effective administration of the controlled materials plan. The Council participated in Washington meetings which resulted in realistic production scheduling on the basis of materials available. During a period in 1943 when material shortages became critical, the Council helped develop substitutes. Members of the Council's conservation panel exchanged information on developments in the field of material conservation through improved manufacturing methods.

During 1943, the West Coast manpower program, based on the Byrnes-Baruch Directive of September 15, was instituted. In the Los Angeles, San Diego and Seattle areas, production urgency committees reviewed the awarding of new contracts on the Pacific Coast, every large city of which was in a No. 1 critical labor shortage area. Manpower priorities committees fixed ceilings for all essential industries. These ceilings were based upon estimated personnel needs, and were subjected to continuous screening and review, to assure warplants of necessary personnel and to channel workers to plants where they could best serve the war effort.

In the Los Angeles area a citizens manpower committee assisted

in arousing community consciousness of the needs of war plants, and gave due recognition to other essential industries. This committee had its counterpart in the Seattle area in the Flying Fortress committee which helped obtain additional workers for Boeing.

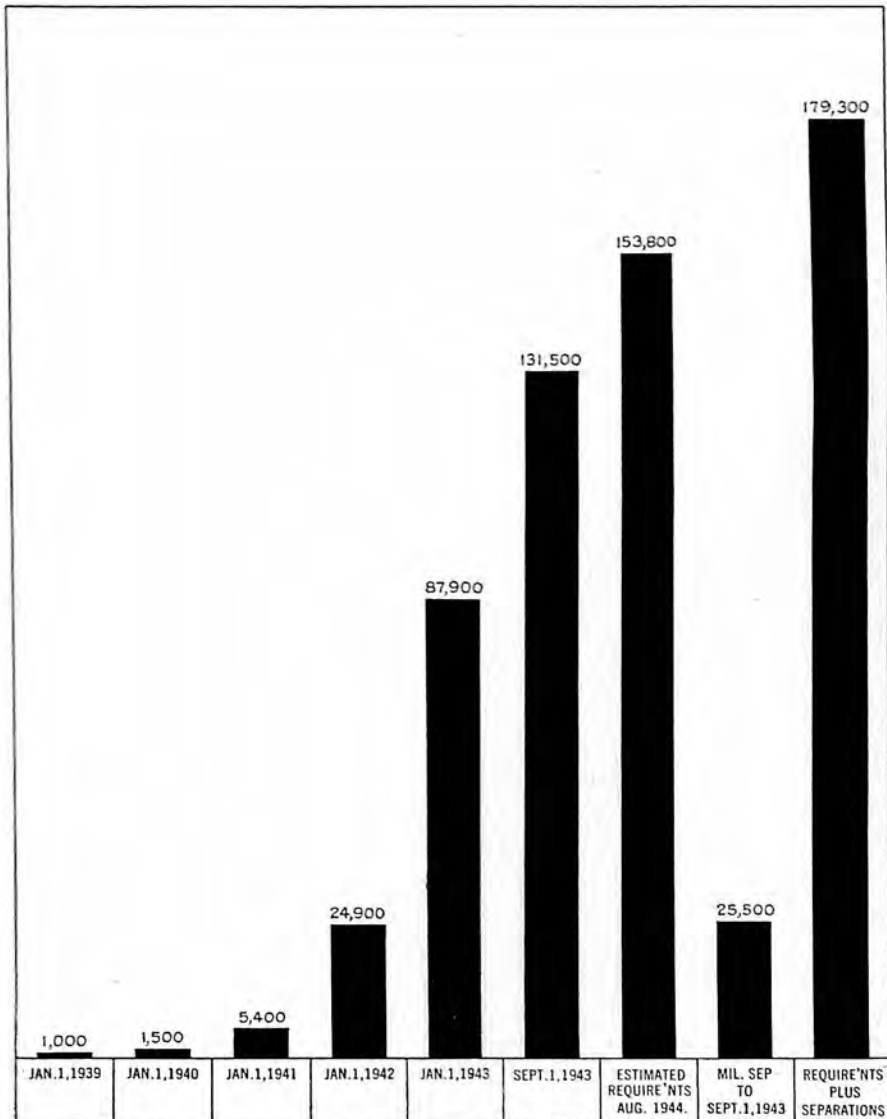

#### AIRCRAFT EMPLOYEES IN MICHIGAN

Estimates prepared by the Aeronautical Chamber of Commerce of America showing status of employment by manufacturers (not including subcontractors) of aircraft, engines and propellers in Michigan.



A special turnover and absenteeism panel helped find answers for those problems by making a monthly statistical analysis of reasons why employees left their jobs or absented themselves from work. Recognizing that almost half of each month's turnover was caused by employees quitting for personal reasons, the Council undertook a major educational program to induce them to stay on the job. Through Council sharing of ideas and methods, member companies developed 88 employee services to meet needs of recreation, health and personal convenience. As an example of the high level attained by industrial medicine, the Lockheed company developed a treatment for the common cold which won national recognition.

During 1943 the industrial safety panel, composed of the safety engineers of member companies, exchanged information on 30 developments. Federal studies established that the frequency rate of injury among aircraft workers in 1942 was 11.4 per cent, far below that of most other major war industries.

The Council, in June, 1943, prepared a report on housing needs in Los Angeles and San Diego, reporting minimum needs. Partly as a result of this report, the National Housing Agency authorized priorities for the construction of 38,000 housing units, of which 21,000 were allotted to aircraft employees. Through its panel of specialists, the Council worked closely with the N.H.A., War Housing Centers, the Army, Navy and other Government agencies to assure speedy construction of war housing.

Member companies of the Aircraft War Production Council, East Coast, were Aviation Corporation, Bell Aircraft Corporation, Curtiss-Wright Corporation, Eastern Aircraft Division of General Motors Corporation, Fairchild Engine and Airplane Corporation, The Glenn L. Martin Company and Republic Aviation Corporation. In addition, subsidiary companies of the parent member companies included American Propeller Corporation, Lycoming Engine Division of Aviation Corporation, Northern Aircraft Products and Republic Aircraft Products (also divisions of Aviation Corporation), Curtiss-Wright Propeller Division and Ranger Engines Division of Fairchild.

Those companies during 1943 delivered a combined total of 24,566 airplanes weighing, with spares, in excess of 180 million pounds. Production of airframes, in dollar volume, was approximately two-and-one-quarter billion dollars. That represented an increase of 105 per cent in unit production and approximately 184 per cent in airframe weight over 1942. Many millions of dollars worth of engines, propellers and parts were added to the production total by the affiliated branches of the Council's parent member companies. This production came from plants in New York, New Jersey, Pennsylvania, Maryland, Ohio, Indiana, Missouri, Michigan, North Carolina, Kentucky, Nebraska and Georgia. It included the manufacture

of nearly every type of plane, including medium and heavy bombers, fighters, patrol, dive and torpedo bombers, cargo planes, primary and advance trainers.

The advisory committees on engineering, production and conservation and reclamation broke all records in the number of information exchanges completed between the Council companies, other industry groups and nonmember companies. For example, the engineering committee completed nearly 600 information exchanges during the last four months period of 1943, to reach a total of 1,597 for the year. They did not include engineering reports exchanges made possible through the Council engineering index. The engineering index of technical reports was completed and made available to all member companies, as well as the National, West Coast and Central Councils. A test and research specialists panel controlled the data to be incorporated in the engineering index.

Approximately 10 AN specifications were reviewed by specialists groups of the Council, and recommendations designed to expedite production were given to the Aeronautical Chamber of Commerce and the working committee of the Aeronautical Board. New advisory committees on spares and quality resulted in increased value to the individual companies due to the number of projects they completed or had under way early in 1944. The quality committee established a materials review procedure and a technical procedure for magnetic inspection. The advisory committee on spares was most active in provisional procedures, echelon pack-ups, consumption data criteria,



AT FAIRCHILD HAGERSTOWN, MD., PLANT  
Part of the engineering offices.

extranet depot operations and 3-Air Appendix A. The general problem of reduction of idle surplus material was solved partly through redistribution methods.

Committees worked on clarification of the manpower situation in the East, as related to aircraft production. The manpower section of the advisory committee on industrial relations-manpower prepared a study of the situation which was presented to the combined East-West Coast boards of directors at the National Council meetings in Washington in September, 1943. It pointed out increases in production by member companies, despite manpower shortages. Many of its conclusions in regard to absenteeism, turnover, in-migration, controlled referral, housing and transportation and wage incentives were accepted by the industry and the Government agencies concerned. A number of its recommendations on labor utilization, selective service, certificates of availability, increased hiring of women, child care, employee and community education received attention and were carried out in whole or in part.

The East Coast Council's specialists panel on labor utilization made an intensive study of utilization methods in use in member company plants. The survey embraced the fields of engineering, factory operations, industrial relations, tooling and other subjects. As a result, utilization methods which had saved literally millions of manhours were described in a report which was distributed widely so that its contents might be helpful in increasing and expediting war production for the Allied cause.

Informational exchanges on such subjects as employee and foreman's manuals, safety clothing, job evaluations, employee ratios, absentee procedures, training methods and exit interview forms were also carried out by the advisory committee on industrial relations-manpower, through the Council. Nearly 600 such exchanges were made in 1943.

Likewise, the advisory committee on plant defense, besides consideration of approved systems of plant protection, exchanged information on such items as badge procedures, fire protection systems, blackout procedures and plant protection manuals. The interchanges resulted in more uniform and improved practices in their field. The committee held meetings with representatives of the Army Provost Marshal's office, from time to time, for the purpose of adopting policies and measures to guard against sabotage and other incidents which could hamper or slow down production.

The East Coast Council's advisory subcommittee on employee services, in addition to housing and transportation, handled problems pertaining to child care, rationing, employee stores and charity drives. The advisory committee on public relations devoted the majority of its meetings to coordinating inplant morale incentive programs and assisting in related industrial relations. As a result of meetings be-

tween this group and Army and Navy authorities, the following projects were completed: A liaison between the committee and the Industrial Services Division, Bureau of Public Relations, War department, worked out by the Council, resulted in setting up a practical program of incentives, including all materials from the War Department conference, films, captive equipment, posters, morale rallies, telegrams and returned combat airmen. These activities were of great morale value in the plants of member companies. Following a formal request from the committee, a special section was formed within the Navy Industrial Incentive Division and given the exclusive assignment of planning incentive programs for the manufacturers and subcontractors of aircraft and aircraft equipment, parts and accessories. The section performed distinguished service for all employees in the aircraft field, not in Council member plants alone, but among all companies in aircraft war production. Special incentive programs were devised for individual plant needs with great success. The East Coast Council, at the direction of the public relations committee, maintained a regular circuit of incentive films to all member companies, obtaining regular reports of the use of these films from the plants and suggesting new material and improvements most likely to increase their value in maintaining and improving production.

#### Institute of the Aeronautical Sciences

The Institute of the Aeronautical Sciences completed its 11th year with more than 5,800 members. Thirty-six meetings were reported by sections of the Institute in Los Angeles, San Diego, Seattle, Detroit, Akron and South Bend. A new section was organized in Buffalo and additional sections are in process of organization in Hartford, Baltimore and Cleveland. Despite the many students



THE CESSNA BOBCAT

Army AT-17 two-engine advanced bomber crew trainer.



BELL P-39 AIRACOBRA

In a night flight, with all guns blazing.

leaving colleges to enter the armed services of the nation, the student branches of the Institute in 39 schools and colleges throughout the country continued to hold meetings. At technical sessions of the annual meeting held in New York in January, 1944, 62 technical papers were presented by specialists on aerodynamics, aircraft production, airplane design, air transport, materials, meteorology, power plants and propellers, radio and instruments, rotating wing aircraft and structures. The meteorological sessions were held in cooperation with the American Meteorological Society.

An expanded program of national meetings was started during the year, with an air transport meeting in Washington, D. C., in October, followed by the seventh Wright Brothers lecture, in Washington in December. The Institute cooperated in sponsoring a dinner in honor of Orville Wright in Washington on December 17, 1943. At an air transport meeting, Government authorities and leaders in the air transport industry spoke on the present and future of air transport. The seventh Wright Brothers Lecture was delivered by W. S. Farren, chief superintendent of the Royal Aircraft Establishment, England, on Research for Aeronautics—Its Planning and Application.

At the honors night dinner on January 24, 1944, the Institute presented its awards for 1943 as follows: The Sylvanus Albert Reed award went to Dr. Sanford A. Moss, General Electric Company, "for development of the turbosupercharger which has made possible the high altitude operation of aircraft." The Octave Chanute award



for scientific achievement by a pilot was given to William H. McAvoy, chief test pilot, Ames Aeronautical Laboratory, N.A.C.A. "for continuous service in the flight testing of experimental airplanes under hazardous conditions imposed in aeronautical research." The Lawrence Sperry award for young men was presented to William Benjamin Bergen, chief flight test engineer of The Glenn L. Martin Company, "for theoretical and experimental studies of dynamic loads on airplanes." The John Jeffries award for outstanding contributions to the advancement of aeronautics through medical research went to Brig. Gen. Eugen G. Reinartz, U.S. Army, Commandant of the Army School of Aviation Medicine, "for his work on the neuropsychiatric aspect of aviation medicine." The Robert M. Losey award in recognition of outstanding contributions to the science of meteorology as applied to aeronautics, was presented to Lt. Col. Joseph Johnson George, U.S. Army Air Forces, "for the development of systematic methods of weather forecasting." The Thurman H. Bane award given to an officer or civilian of the Army Air Forces Materiel Command for an important technical achievement in aeronautics during 1943 went to Col. Hollingsworth F. Gregory, U.S. Army Air Forces, "for his



THE KELLETT AUTOGIRO

The direct-lift of the rotor blades of this Kellett YO-60 Army autogyro lifts the craft from the ground quickly completing the sort of take-off which frees rotary wing aircraft from dependence on airport or normal landing areas. The YO-60 was powered by a Jacobs 300 h.p. engine.



U. S. A. A. F. photo

#### BEECHCRAFT ADVANCED ARMY TRAINERS

Model AT-11 Kansan, used by the Army Air Forces for specialized training of bombardiers and gunners. These trainers were equipped with flexible guns and bomb racks.

contribution to the military and commercial development of the helicopter."

#### Manufacturers Aircraft Association

In 1918, Samuel S. Bradley, as the principal managing executive of the Manufacturers Aircraft Association, and Frank H. Russell, its first president, presented a report of the first 12 months of operations under the Cross-License Agreement between aircraft manufacturers in the United States. Although the first world war was then approaching the crisis which shortly was to result in defeat for the enemy on all fronts, the aircraft industry was still confronted with a war program of tremendous proportions. The practicability of the cross-licensing plan, however, already had been clearly demonstrated and our greatly accelerated aircraft production schedules no longer were being hampered by delay caused by wasteful litigation and other injurious controversies over patents. Early in 1944, those same men, still officers of the Association, rendered an annual report stating that the basic principles which served as a guide and inspiration to all manufacturers throughout the first world war again had made it possible for the aircraft industry to adhere to farsighted production schedules which were a most important aid to victory in the second world war. Through persistent leadership in research and design, American manufacturers of aircraft were able to maintain a degree of supremacy in the quality of their respective products unequalled by any other nation. Never before had the art of aircraft design and production

made so much progress. Throughout, the most advanced ideas were made available to all manufacturers by facilities of the Association. Two hundred and six patents were acquired by members of the Association during 1943. A total of 1,434 patents had been brought under the operation of the agreement since it was set up. The original policy of making licenses on the same terms available to all aircraft manufacturers and also to the United States Government had prevailed since 1917. All the other facilities referred to in previous editions of the Aircraft Year Book, as well as the various services rendered by the Association's patent research division, were maintained. As in the case of the elimination of patent litigation between members because of the Cross-License Agreement, the Association also succeeded in establishing a somewhat similar situation regarding the relationship with nonmember patent owners desiring to make worthwhile inventions available to the aircraft industry. The advantages of the Cross-License Agreement to the industry, to the Government and to the public were important contributions to the war effort. Member-



THE DOUGLAS A-20 HAVOC BOMBER  
Showing the terrific firepower in the nose.



#### AT BELLANCA AIRCRAFT PLANT

Assembly floor view showing Fairchild AT-21 Gunner trainers in production.

ship in the Association was not restricted. No qualified applicant had ever been refused the right to acquire licenses under the terms of the Agreement. There never had been any withdrawals from the Association, except in the case of companies which either had gone out of business or ceased manufacture of aircraft.

Worthy of note was the fact that as a direct effect of operations under the Cross-License Agreement, there was no price fixing within the aircraft industry, no regulation or control of markets, nor any other restriction on the sale of products. Patents of lesser consequence which might have been grouped for the purpose of controlling certain aspects of the art were licensed free of charge. Inventions of a more basic character, which otherwise might have been held by individual companies to dominate the industry or withheld for the purpose of preventing competition, were made available at royalty rates permitting unlimited use by every member of the Association of all inventions coming within the operation of the Cross-License Agreement.

#### Society of Automotive Engineers

The Society of Automotive Engineers expanded its aircraft standardization program. Approximately one third of the membership was made up of personnel from the aircraft industry, total membership increasing in 1943 to more than 10,000 from 8,200 in 1942. Under the S.A.E. aeronautics division, the S.A.E. aircraft standardization program was carried on with the aid of approximately 225 outstanding technicians of the aircraft industry, requiring 43 separate committees.

The activities of the Aeronautics Division included development of design and dimensional standards for aircraft engines, propellers and accessories and specifications for materials and processes used by the manufacturers of aircraft engines, propellers, accessories and airframes. In this work, the 43 committees served two separate and distinct technical functions. They developed standards and specifications satisfactory to industry for publication and distribution by the S.A.E. They also advised Government and other agencies on standards and other technical matters of broad industrial importance.

The S.A.E. published 25 new and revised Aeronautical Standards and Aeronautical Recommended Practices (AS and ARP Series). The number of S.A.E. Aeronautical Material Specifications (AMS Series) available to and used by the industry was increased to 300 with the preparation, approval, and distribution of 24 new and of 44 revised specifications. The series of specifications received endorsement by the Army Air Forces and the Navy Bureau of Aeronautics for use on military aircraft. More than 2,250,000 copies went into circulation. In 1943 three Aeronautical Information Reports and several restricted reports were prepared. The S.A.E. Manual of Aircraft Engine Drafting Room Practice was modernized and expanded.

The committees were particularly active in advising and in consulting with the Government and other agencies on standards. Their work included developing and forwarding recommendations to the working committee of the Aeronautical Board on proposed AN Aeronautical Standards and Specifications, and forwarding technical recommendations to the engine technical committee of the Aeronautical Chamber of Commerce. Plans and procedures were established for exchange of technical information and completed standards with the interested standards organizations of other countries, including the Society of British Aircraft Constructors, the Canadian Engineering Standards Association and the Standards Association of Australia. A total of 131 technical papers were presented at four S.A.E. national meetings and at local meetings of 25 S.A.E. sections.



FAIRCHILD PLANT AT BURLINGTON, N. C.

Final assembly of AT-21 Gunner trainers.



The S.A.E. Manly Memorial Award for the best paper presented at an S.A.E. meeting on theory, practice, design, construction or research in the field of aircraft powerplants, parts or accessories, was presented to John Dolza and H. A. Karcher, of Allison Division, General Motors Corporation, for their joint technical paper, "Correlation of Ground and Altitude Performance of Oil Systems," delivered before the S.A.E. Detroit Section in June, 1942. The S.A.E. Wright Brothers Medal for the best paper on aerodynamics, structural theory or research in the field of airplane design was awarded to Charles R. Strang, of Douglas Aircraft Company, for his technical paper, "Progress in Structural Design Through Strain-Gage Technique," delivered at the S.A.E. 1942 Annual Meeting in Detroit.

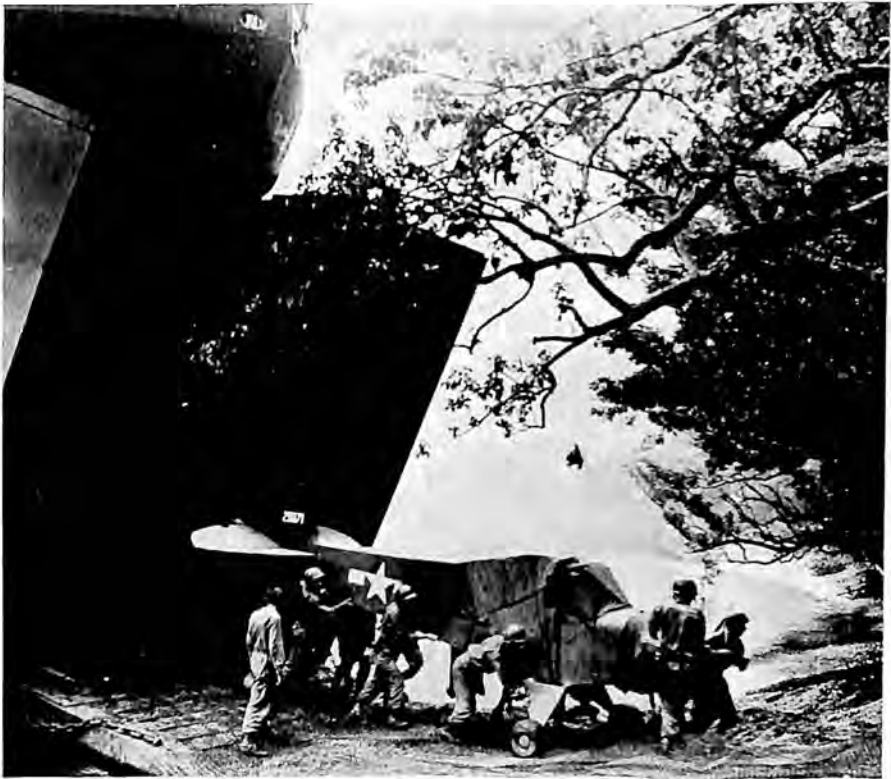

U. S. Signal Corps photo

#### GOING ASHORE IN NEW GUINEA

Members of a United States Army unit unload a Piper Cub plane to be used for artillery observation after their landing on the beach at Saidor, New Guinea.

## CHAPTER X

### NEW THINGS IN THE AIR

**T**HE aircraft manufacturing industry of the United States developed thousands of new things to maintain the superiority of American planes which were operating against the enemy on all fronts of the global war. At the same time, the industry, assisted by a legion of purveyors, subcontractors and licensees in other industries, reached peak production of all kinds of aeronautical equipment. This fine record was recognized by the War Department when on March 9, 1944, in an official statement about the growth of the Army Air Forces, it stated: "American industry has been geared to a combat aircraft construction program greater than that of any other nation. Not only has it made possible the creation of American air power; it has helped supply the combat and training squadrons of our Allies."

The following pages show how the manufacturers have contributed to the development and production program that keeps America ahead in the air.

#### Aircraft Manufacturers

Aeronca Aircraft Corporation, Middletown, O., produced the L-3 Grasshopper plane, the PT-23AE and PT-19B AE primary trainers for the Army Air Forces, and also produced elevators for the B-17 Flying Fortress. Production schedules were met each month. On August 10, 1943, Aeronca received the Army-Navy E award for its fine production record. In 1944 Aeronca was to continue production of the L-3 and the PT-19, as well as begin production on the UC-64A, a cargo plane powered with a 500 h.p. Pratt and Whitney Wasp. This plane was designed and formerly built by the Noorduyn Aircraft Ltd. of Montreal, Canada. The Aeronca L-3 Grasshopper plane was used for observation and liaison in conjunction with the Field Artillery. Powered by a 65 h.p. Continental motor, it was especially adaptable for spotting enemy entrenchments, directing artillery fire, and transporting personnel in and out of places too small for larger planes to land. The Aeronca PT-23AE was powered by a 220 h.p. Continental motor. It was a low-wing, primary trainer used by the Army Air Forces. The fuselage was constructed of steel tubing, fabric covered. It had all metal fabric-covered control surfaces. The Aeronca PT-19B AE was powered by a 175 h.p. Ranger aircooled inline inverted engine, and was a primary trainer, of the same design as the PT-23AE except for motor and cowlings.

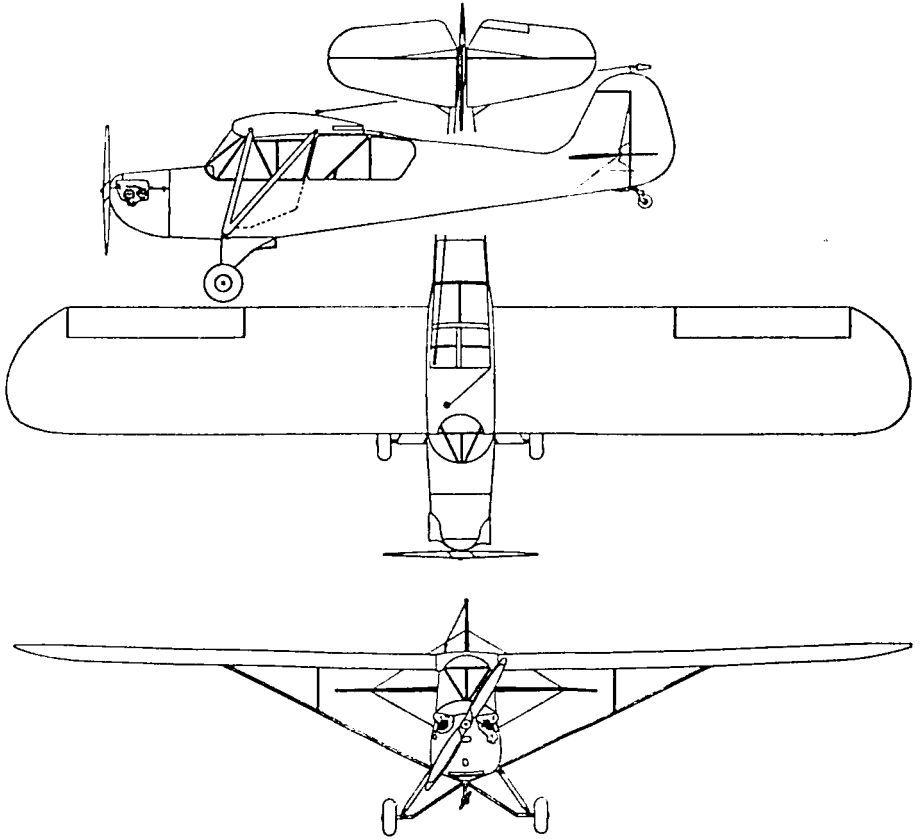

#### AERONCA LIAISON PLANE

Army Air Forces Type L-3. A two-place plane with a Continental 65 h.p. engine.

Beech Aircraft Corporation, Wichita, Kans., increased deliveries of Beechcraft twin-engine monoplane advanced trainers and transports, and single-engine biplane transports for the armed services by a ratio of 227 per cent in comparison with 1942. Production schedules were maintained every month throughout 1943. The 227 per cent increase was attained, despite additions to plant facilities of only 5¼ per cent in terms of total floor area. Greater efficiency in the use of existing facilities was the primary cause, and it was achieved through close cooperation between employees and management.

Beech employees had brought their total purchases of war bonds to an average of more than \$1,000 per employee since the beginning of the war. They kept down their absenteeism rate, and their rate of turnover from causes other than military inductions, to a rate approximately half that of the entire industry. More than 3,000 employees were inducted into the armed services during the first nine months of 1943. Compared with the national aircraft average, Beech

inductions were 220 per cent of the general average. Replacements were effected through up-grading, made possible by many Beech-sponsored training courses which increased the skill level of inexperienced workers.

The Beech subcontracting program, instituted in 1939 as one of the first large scale operations of its kind in the industry, was continued extensively as a means of utilizing the facilities and manpower of smaller manufacturers in the area from the Rocky Mountains to Ohio, and from the Canadian border to the Gulf of Mexico. At the end of 1943, a wartime total of more than \$50,000,000 worth of completed subassemblies and parts had been delivered to Beech by its subcontractors. They utilized, in reaching this total, more floor area than that in the Beech factory, and employed more than half as many persons as the total on the Beech payroll. Strict control of quality by the Beech outside production department rendered the subcontracted units fully interchangeable with those built in the Beech factory.

A system of adjusted wage or salary incentive payments for all employees, based on a production efficiency basis measured by pounds of airplanes produced per man-hour expended, and known since its inception in 1941 as the Beech efficiency incentive plan, attracted nationwide attention. Similar systems patterned after this plan were adopted by other leading aircraft manufacturers with the approval of the Government.

Five different types of Beechcrafts were produced in large quanti-



THE AERONCA L-3 GRASSHOPPER  
Used by the Army in liaison operations.

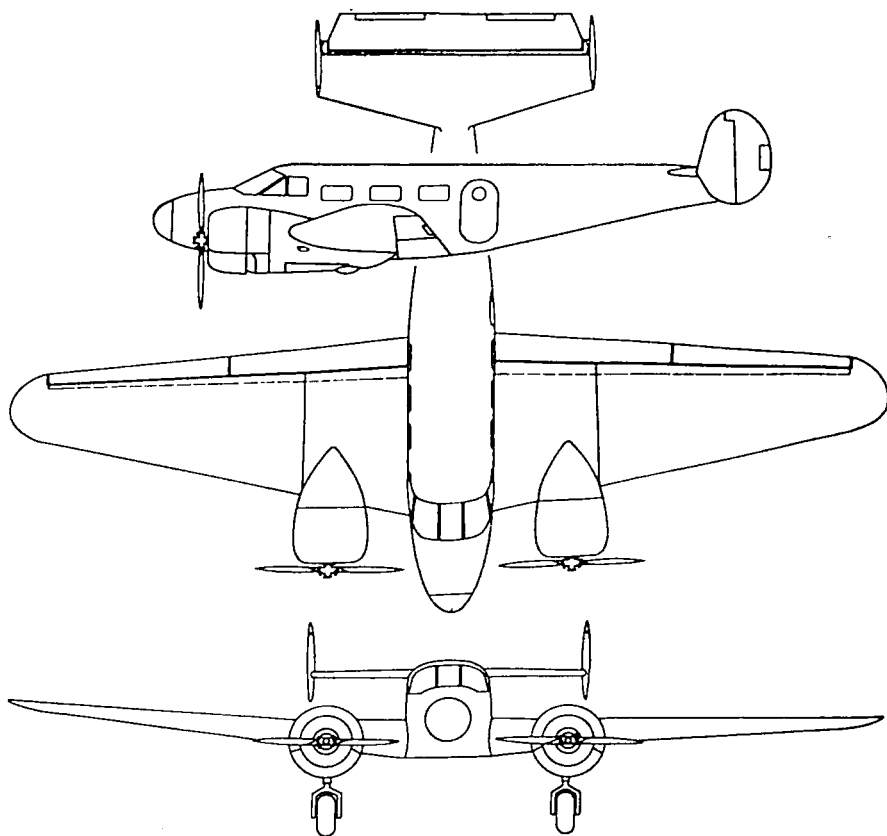

**BEECHCRAFT MODEL 18**

Various adaptations of this twin-engine monoplane were used by the Army Air Forces and Navy air forces as navigation or bombing trainer, utility or personnel transport, or photographic plane. It was powered by two 450 h.p. Pratt & Whitney Wasp Junior engines.

ties. The Army AT-7 (Navy SNB-2) navigation trainer, and the Army AT-11 (Navy SNB-1) bombing trainer, were continued in large-scale production as major navigation and bombardment training planes of the Army Air Forces. Also produced in quantity was the Army UC-45B, a personnel and utility transport adaptable for use also as a navigation trainer. All those types were adaptations of the basic commercial Model 18 Beechcraft all metal low-wing twin-engine monoplane, powered with two Pratt & Whitney 450 h.p. Wasp Junior engines. Another commercial Beechcraft, the Model 17 single-engine 450 h.p. negative-stagger biplane, of welded steel tubing fuselage and wood wing construction, was produced in substantial quantities for the armed services as the Army UC-43 and the Navy GB-2.

The last of many hundreds of Army AT-10 Beechcraft twin-engine transitional trainers built under then current contracts rolled



off the Beech assembly lines during 1943. Designed by Beech engineers in 1940, in cooperation with the Army Air Forces, the AT-10 Beechcraft was intended for rapid large scale production from then noncritical materials. An all wood low-wing monoplane with two Lycoming 290 h.p. engines, it carried all of the flight control equipment required by pilots on the largest multi-engine tactical aircraft, and simulated the performance characteristics of the larger combat planes. Completion of the AT-10 contract on schedule allowed acceleration in delivery rates of other types of Beechcrafts, and also freed

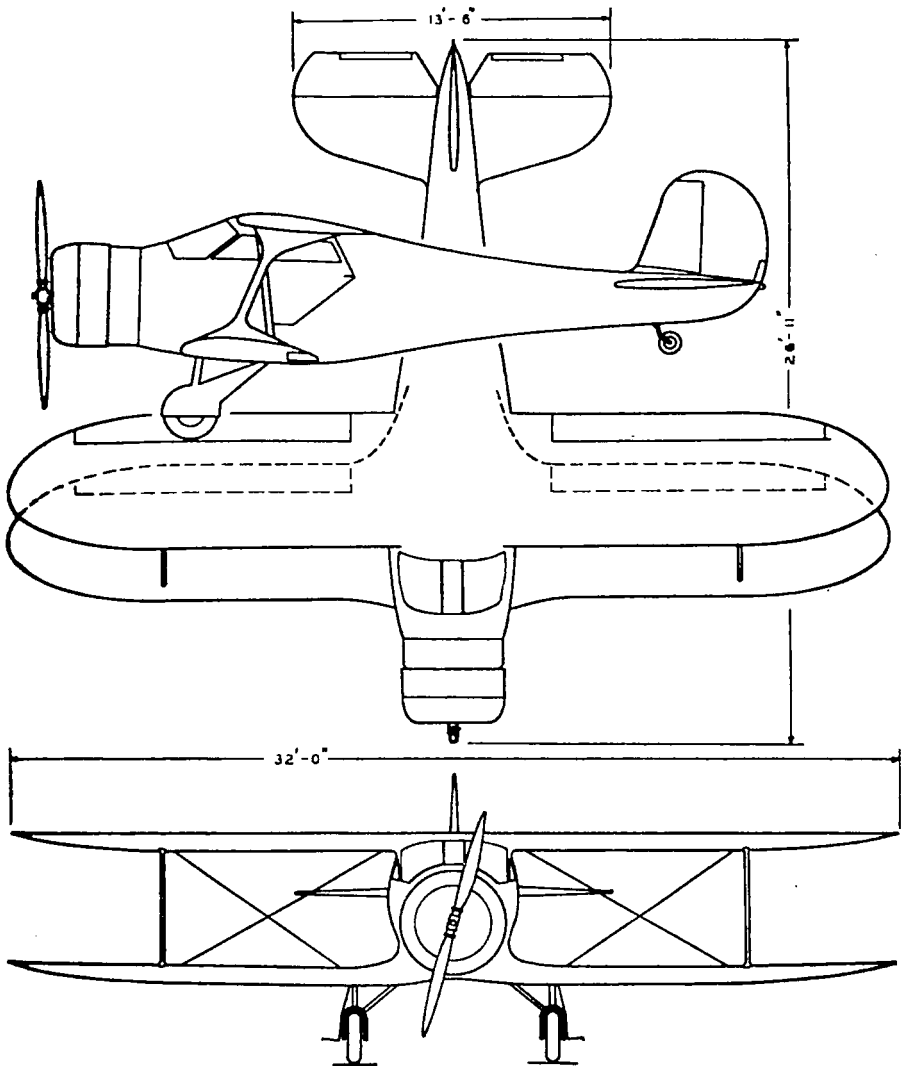

#### BEECHCRAFT PERSONNEL TRANSPORT

Used as a utility transport also, the Army designation was C-43 and the Navy designation GB-2.



#### MORE AIRACOBRAS TO STRIKE THE AXIS

As the war in the air expanded into ferocious activity on all fronts, ever increasing numbers of these heavily firepowered P-39 fighters were speeded off the assembly lines of the Bell Aircraft plants. Besides being used by our Army Air Forces on all fronts from Iceland to India, they were sent over to help Russia.

a portion of plant and subcontractor facilities for the manufacture of complete wing assemblies for a new combat plane still on the secret list. At the beginning of 1944, Beech had a backlog of orders amounting to \$125,000,000.

Bell Aircraft Corporation, Buffalo, N. Y., had three aircraft plants in operation—at Buffalo, Niagara Falls and Marietta, Ga.—and an ordnance plant at Burlington, Vt. Bell continued at peak production on the P-39 Airacobra fighter for our Army Air Forces and the Russian air force, while at the same time producing a new model fighter characterized by the Office of War Information as being equipped with “a long wing and a two stage Allison supercharged engine which would make it an efficient plane at any altitude up to 38,000 or 40,000 feet; and like the P-39, the new plane would be equipped with cannon as well as machine guns.”

On January 6, 1944, announcement was made by the Army Air Forces that Bell Aircraft Corporation had built and successfully test flown a jet propelled fighter airplane. The release went on to say that “several hundred successful flights have been carried out by American pilots in the United States and by British pilots with the British aircraft in England, many of them at extreme speeds and high altitudes—all without a single mishap. Because of this successful record and the obvious advantage of this new type of airplane, the Commanding General of the Army Air Forces, the British Air Ministry and the Ministry of Aircraft Production have directed that plans be made for the production of a sufficient quantity for training purposes both

in Great Britain and in the United States. The Army Air Forces are allotting a number of these to the United States Navy for additional tests and experimentation.

"The maiden flight of the first experimental ship in the United States took place on October 1, 1942. This was the first successful operation of a combat plane using the jet propulsion principle. Robert

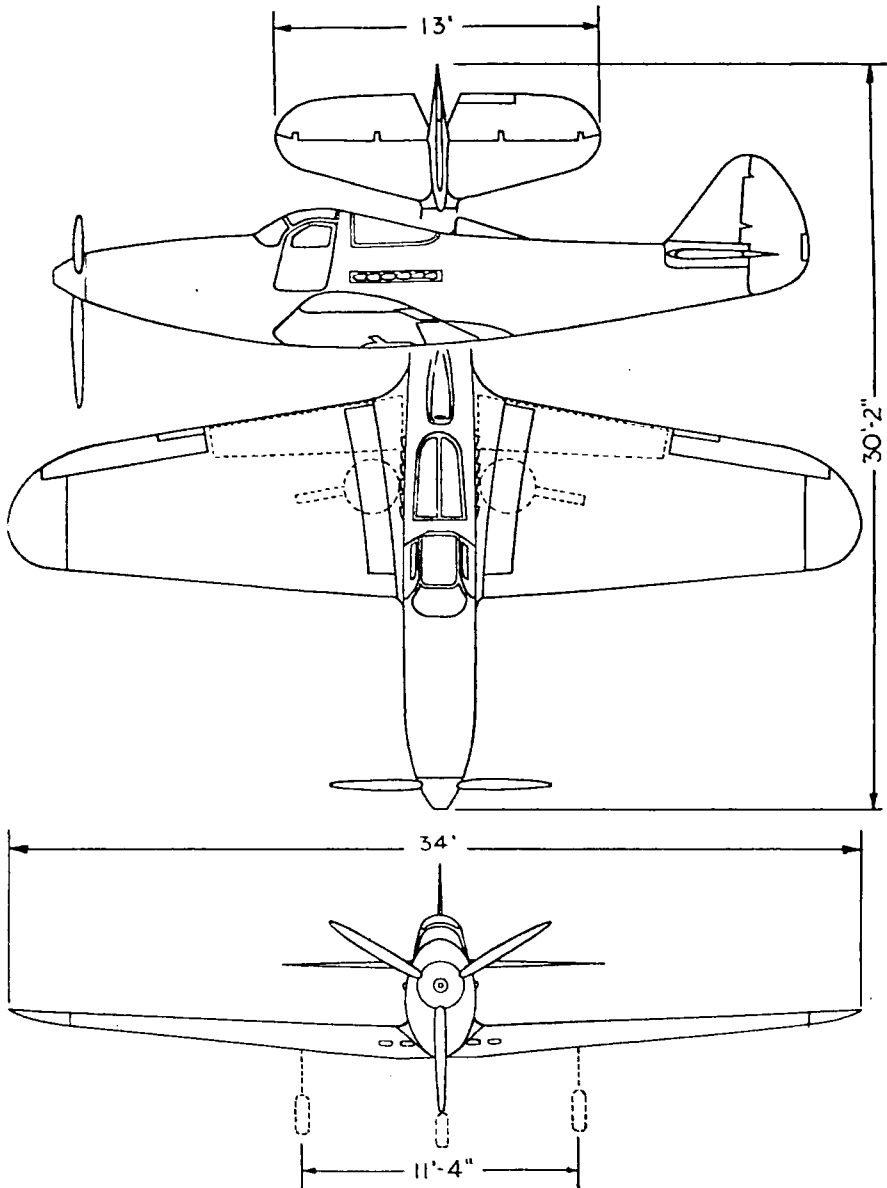

BELL P-39 AIRACOBRA

This single-seat interceptor fighter was powered by an Allison engine.

M. Stanley, Bell Aircraft chief test pilot was at the controls on the initial flight. The following day Brig. Gen. (then Colonel) Lawrence C. Craigie flew the ship, thus becoming the first Army officer to fly a jet propelled military aircraft in this country."

Little publicized, but reportedly packed with significance was the quiet construction of a helicopter by Bell Aircraft. The Bell plant in Georgia was devoted solely to production of the Boeing B-29 Army Air Forces bomber.

During 1943, Bell Aircraft took steps to secure additional employees for its fighter plane manufacturing program. First, the company started a victory shift, whereby both men and women, whose business or family responsibilities kept them from taking fulltime war-plant jobs, were encouraged to sign up for three day shifts each week. Approximately 2,000 victory shifters were enlisted for Airacobra construction, thus helping substantially in production efforts.

At the beginning of the new school year in September, 1943, Bell Aircraft announced to the hundreds of 'teen-age boys working at its plants that they were expected to continue with their education, despite the appeal which warplane paychecks held for them. At the same time, Bell started a boypower program, wherein boys would work three nights a week, on the second shift, provided they maintained a satisfactory scholastic standing.

The Bell P-39 Airacobra had a remarkable record for efficiency in combat over the war fronts. Our Army Air Forces used it against the best the Japs could put in the air, and our pilots blasted the Nipponese out of the skies on every encounter, with a ratio of about five to one in our favor. Nowhere were American fighter planes more popular than on the Russian front where the gallant and heroic pilots of the Red Air Fleet admired the infallibly staunch construction of the Bell Airacobra and its great firepower which gave them a decided advantage over German planes and augmented the terrific striking power of their own excellent planes produced in the Soviet Union.

The Bell P-39 Airacobra had been in the war from the beginning, and there was little that the enemy did not know about it, from both combat action in the air and occasional landings of the Airacobra behind the lines. With that in mind, our Army Air Forces permitted certain details to be published for the record. The Airacobra was a single seat fighter—with a wing span of 34 ft., length 30 ft. 2 in. and height 9 ft. 3¼ in., wing area 213.22 sq. ft., wing loading 35.4 lb. per sq. ft., weight empty 5,523.2 lb., gross weight 7,403.5 lb. The fuselage was in two sections, the front section with two longitudinal beams extending its entire length. Those girders supported engine, propeller reduction gear box, extension drive shaft, fuselage guns, ammunition and pilot, with the pilot's cabin set in front of the engine integral with the fuselage. The power plant was the Allison V-1710 engine rated 1,150 h.p. at 15,000 ft., with three-blade propeller. j

Bellanca Aircraft Corporation, New Castle, Del., was in production on the Fairchild AT-21 twin-engine gunnery crew trainer for the Army Air Forces. The Bellanca organization had an extensive war record as a subcontractor—producing large numbers of gun turrets for United Nations bombers, all-metal riveted seaplane floats, plastic plywood bomb bay doors, riveted all-metal fins and miscellaneous electrical junction boxes, de-icer fluid tanks and hydraulic fluid tanks.

Boeing Aircraft Company, Seattle, Wash., made new production records in the manufacture of its Flying Fortresses, the four-motored, long-range bombers that were employed in the Army Air Forces with deadly results for the enemy in several war theaters. In 1943 production was 146 per cent greater than during the previous 12 months. December's output was the highest for a single month in the company's history. It was 92 per cent higher than during the first month of 1943 and was ten times greater than during the month preceding Pearl Harbor. Further improvement in Boeing's already highly efficient multiline assembly system, through design and use of Boeing-built machines to save man hours, was greatly responsible for the economy in time and cost. Boeing was producing a Flying For-

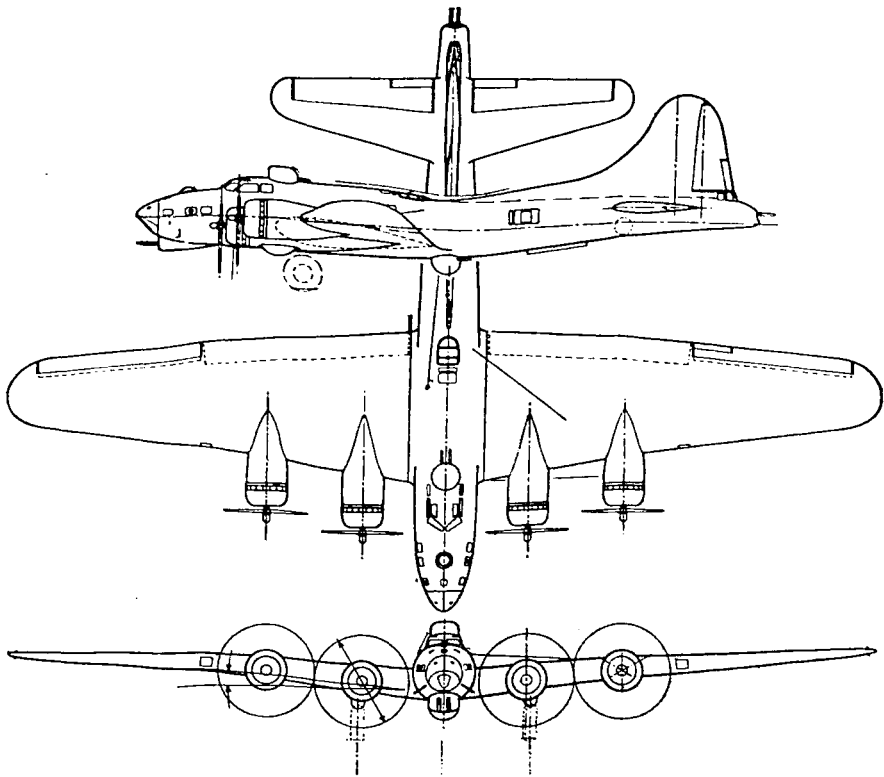

THE BOEING B-17G FLYING FORTRESS



ness in one-third the man hours required in 1941. It is significant that the cost contract price of the Fortress was reduced by one-half in the face of a 27 per cent increase in labor rates since Pearl Harbor.

During 1943, Boeing began production of the ninth of its series of Flying Fortresses, the B-17G. The main physical characteristic, which differentiated it from the B-17F model, was the chin turret, mounted below the plexiglass nose. This turret was armed with twin, .50-cal. machine guns that operated by remote control from the bombardier's station. Bringing the Flying Fortress' armament to 13 .50-cal. machine guns, the chin turret gave the big bomber the most devastating firepower of any battle plane in combat at the end of the year. The ability of the Fortress to mete out punishment was reflected by the box score of Nazi airplanes shot down in raids over German-held territory. The Boeing bombers which raided the Messerschmitt factory at Regensburg on April 18, 1943, and then flew on to temporary bases in Africa, were credited with shooting down 140 enemy planes. On the same day another Fortress formation bombed the roller bearing plant at Schweinfurt and destroyed 147 enemy fighters. The American Eighth Air Force Headquarters announced that of the August toll of 631 enemy planes destroyed by Americans, 541 were brought down by gunners in Flying Fortresses.

Ability of the Fortress to take punishment and still return to its home base was demonstrated repeatedly. The B-17 "Knockout Dropper" still was in action after completing 50 missions over Europe, accumulating more than 300 combat hours, dropping 225,000 lbs. of bombs, expending 75,000 rounds of .50-cal. ammunition and downing 12 enemy fighters. While most Flying Fortresses were diverted to the European theater of war, where their ability to plough through heavy curtains of "flak" and enemy fighters made them indispensable, many others were active on other battlefronts.

As was the case with previous model changes, transformation to model B-17G was accomplished without slowdown or interruption in production schedules. Beside the addition of the chin turret, there were several hundred other changes in design, most of them minor and dictated largely by battle experience. The total changes made a bomber of longer range, higher altitude possibilities, more intensive firepower and greater bomb load.

Boeing's production record in 1943 was made despite a critical manpower shortage during the summer months and in the face of the fact that it was necessary, during the year, to replace thousands of men with unskilled women workers. Half of the Boeing workers early in 1944 were women. Manpower was increased during the last four months of the year by a recruitment campaign in the Northwest and Middle West aided by the introduction of a new job evaluation plan embodying wage increases approved by the War Labor Board in September, 1943.

Boeing established six branch plants in five western Washington cities. Two were in Tacoma and one each in Bellingham, Everett, Chehalis and Aberdeen. These branches, turning out B-17 subassemblies, tapped a labor market unavailable to the Seattle plant. Boeing took steps to combat wartime problems of absenteeism and labor turnover by adding to employees' service organizations. Branch bank facilities were opened at the plant, giving workers checking, saving, check-cashing, bank draft and other services. A tire repair and re-

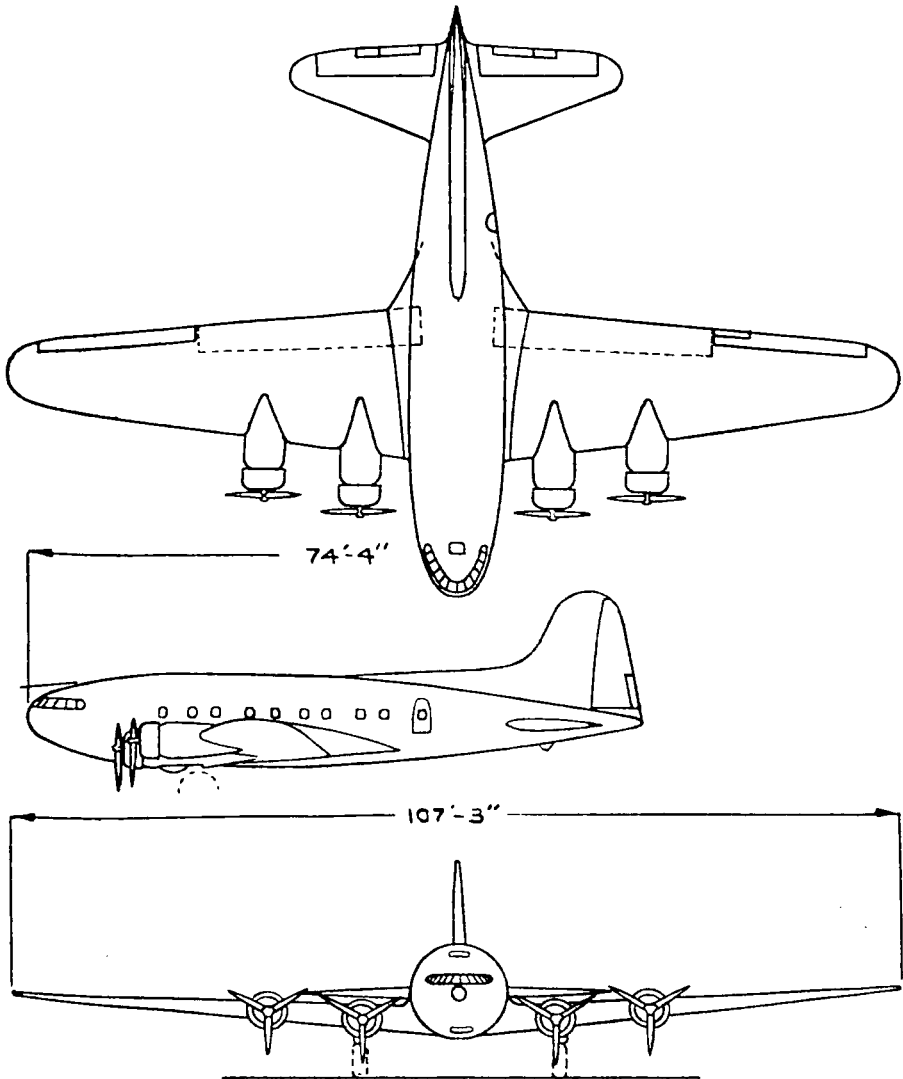

#### THE BOEING STRATOLINER

A 38-place transport for substratosphere operations. It was powered by four Wright Cyclone engines of 1,100 h.p. each.

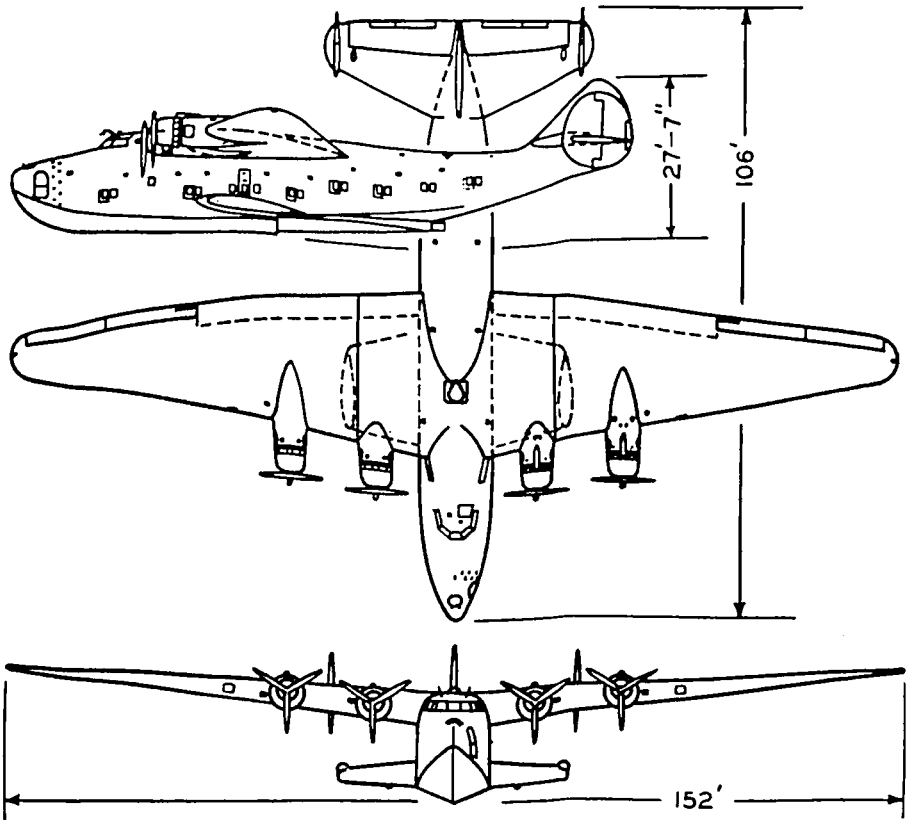

#### THE BOEING 314

Pan American Clipper ship in ocean passenger service, powered by four 1,500 h.p. Wright Cyclone engines.

capping center was established where automobile tires could be repaired while the employee was at work. Spare tires were loaned free of charge when recapping was necessary so no automobile had to be laid up. A transportation department arranged for gas rations and ride sharing.

An elaborate \$750,000 in-plant feeding program, with a cafeteria at one end of the plant to seat 1,600 persons and a food center at the other from which 40 thermos-equipped hot food trucks would operate throughout the plant, was started.

Typical of the many time-saving tools designed and manufactured by Boeing engineers, which made possible the great reduction of man hours required to build a Fortress, was the Porcupine punch. This machine, in one operation, could punch as many as 388 rivet holes, speeding up a single operation by as much as 30 times. Many other such new devices were introduced into the ever-accelerating production system.

Boeing flight test engineers marked another important addition

to stratosphere research with the introduction of the Strato-trainer, a pressurized chamber designed to continue the training of men for exploration in the skies above 35,000 feet. The Strato-trainer, supplementing the Boeing Strato-chamber introduced three years before for mechanical research in high altitude operation, was large enough to hold the entire crew of a Flying Fortress. Conditions of higher altitude could be brought about and at a faster rate than in the former Strato-chamber. An atmosphere equal to that of 50,000 feet could be created in four minutes. While the study of human physiological reactions and behavior at high altitudes was an important function of the Strato-trainer, its primary purpose was the training of crews in safety precautions to prevent swift death in actual stratosphere flights.

The Boeing flight research department carried on constant research and development work at extreme high altitudes. These test engineers were credited with spending more time in the sub-stratosphere than any other fliers in the world. One of the noteworthy

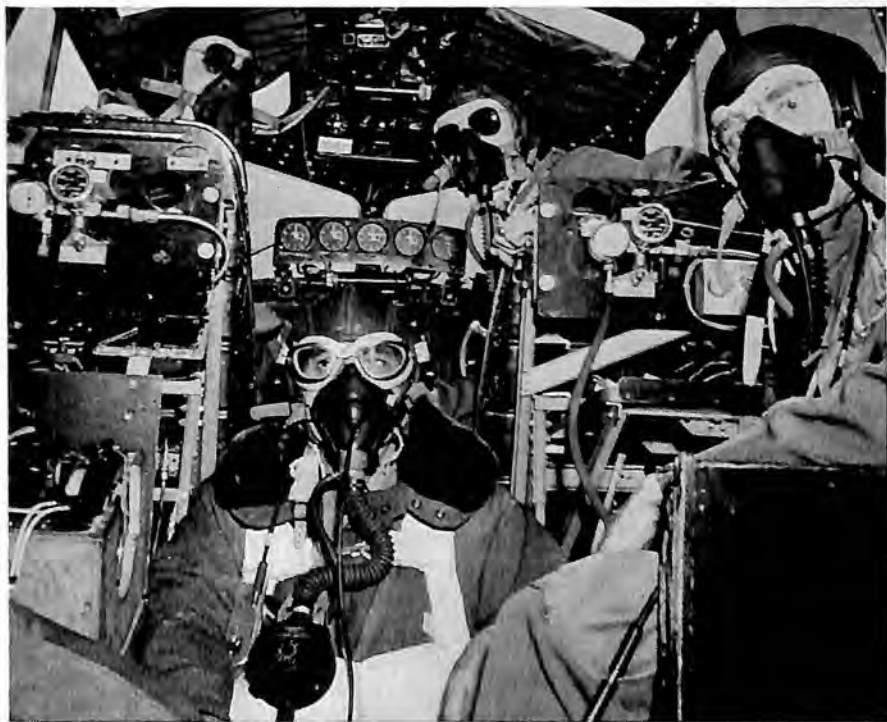

#### HE MADE A RECORD PARACHUTE JUMP

Lt. Col. W. R. Lovelace of the U. S. Army Air Forces (center) is shown with three members of the Boeing Aircraft Company flight test department in the Boeing Flying Fortress just before going aloft to an altitude of 40,200 feet, from which Lovelace descended in a record-breaking parachute jump. Wearing an emergency oxygen outfit, Lovelace made the jump to determine if it was possible to parachute all the way from the stratosphere.

stratosphere experiments in which Boeing took a part was the 40,200-foot parachute leap from a Flying Fortress by Lt. Col. W. R. Lovelace, former Mayo Clinic surgeon and acting chief of the aero-medical laboratories at Wright Field. Major Boris Kharakhonoff of the Russian Army had leaped from the higher distance of 40,813 feet but he had not opened his parachute until he was 2,100 feet from the ground. He plummeted through the perils of the sub-stratosphere to the warmer, breathable air of 2,100 feet in a minute and a half. Col. Lovelace performed a feat which no man ever before had done or attempted. Wearing an emergency oxygen mask, he opened his parachute at once and drifted at parachute speed to the earth. The entire descent was made in 23 minutes 51 seconds. He took nine minutes to descend from 40,200 to 22,000 feet. Col. Lovelace lost consciousness when his parachute jerked open, but Boeing test pilots in a plane circling at a lower altitude noted that he waved his hand at the 8,000-foot level. The leap was made over Eastern Washington and Col. Lovelace landed in a wheat field, suffering from shock, nausea and anoxia. His left hand was frozen as his left glove had fallen off when the chute opened. Only on rare occasions would it be necessary to parachute from an airplane at 40,000 feet as it would be better to ride the ship down part way. Col. Lovelace's experiment proved that it could be done but only with the use of emergency equipment.

One of the most important of Boeing's activities, but one which was still held largely secret, was the completion of testing and the start of production of the giant Superfortress, the Boeing B-29. This bomber, the greatest air weapon ever to roam the skies, was a closely guarded secret with only meager details of its power and potentialities released. Gen. H. H. Arnold, commanding the Army Air Forces, revealed in a carefully worded announcement that the B-29 was a plane which placed previous four-motored bombers in the "light-heavy" class. "The B-29 will have a range substantially greater than the maximum effective range of today's longest-range heavy bombers, and it will carry quite sizeable bombloads for that distance." Gen. Arnold said. "This battleship of the air is armored heavily with multiple-gun, power turrets and can fly at very high altitudes."

Gen. Arnold characterized as "superb" the combat records of previous heavy bombers, the B-17 Boeing Flying Fortresses and the B-24 Consolidated Liberators, but said that the Boeing B-29 "is as far ahead of these two aircraft as they are out in front of pre-war bombers."

Boeing Stratoliners, operated by TWA and Pan American Airways, continued their systematic job of transporting vital war personnel and cargo throughout the Western Hemisphere. Boeing Clippers, the four-motored flying boats which were making the trip from the United States to Europe a routine journey, continued in their transatlantic operations for Pan American.



Boeing Airplane Company's Wichita, Kans., Division concentrated a major part of its greatly expanded facilities and manpower on beginning production of the B-29 Superfortress for the Army Air Forces. During the conversion to big bomber production, the Wichita Division maintained schedules in production of the PT-17 and PT-13D trainers for the Air Forces, the N2S-3, N2S-4 and N2S-5 for the Navy, and the PT-13D/N2S-5 for both the Army and the Navy. The PT-17, N2S-3 and N2S-4 were powered by Continental 220 h.p. engines. The PT-13D, N2S-5 and the standardized version PT-13D/N2S-5 were powered by Lycoming 220 h.p. engines. All primary trainers produced by the Boeing Wichita Division were basically similar types, known as Caydets.

By Jan. 1, 1944, the Wichita Division had produced more than 9,000 Caydets and equivalent planes in spare parts. In quantity production before Pearl Harbor, the Boeing primary trainer assembly line was rolling out a ship every 90 minutes soon after President Roosevelt's request for 50,000 airplanes early in 1942. These Boeing trainers were in use by many allied nations and by 42 Navy Air Stations and Army Air Forces flying training detachments.

The PT-13D/N2S-5 was an open cockpit two-place biplane with tandem seating arrangement. Its high maneuverability and rugged construction made it particularly well suited to its job as a primary trainer. It had a wing span of 32 ft. 2 in. Its length was 25 ft., height 9 ft. 2 in., wing area 297.6 sq. ft., gross weight 2,808.7 lbs. Its maximum speed was 122 m.p.h. and its cruising range approximately 405 mi. on training flights.

The fuselage was of welded chrome-molybdenum steel-tube, covered forward with metal panels and aft with fabric. The wing structure consisted of solid or laminated Douglas Fir spars and diagonally trussed spruce ribs, duraluminum channel compression struts and steel tie-rod bracing. The wings were fabric covered. Landing gear was of divided cantilever type, with hydraulic wheel brakes. A steerable tail wheel added to ground maneuverability.

Brewster Aeronautical Corporation, Long Island City, New York, with another plant at Johnsville, Pa., was in production on Vought Corsairs for the Navy. In December, 1943, and during the first four months of 1944, Brewster exceeded its quota, averaging more than four Corsairs a day; and the Navy authorized an increase to five a day by June, 1944.

Cessna Aircraft Company, Wichita, Kans., built three different models of airplanes. The AT-17 Bobcat was a two-engine bomber-pilot trainer used by the Army Air Forces. The Cessna Crane was a similar plane with equipment for sub-zero operations by the Royal Canadian Air Force. The Cessna Army personnel transport was a twin-engine model known as C-78. It was constructed of plywood and fabric around a welded steel tubing fuselage, and seated 5 persons.

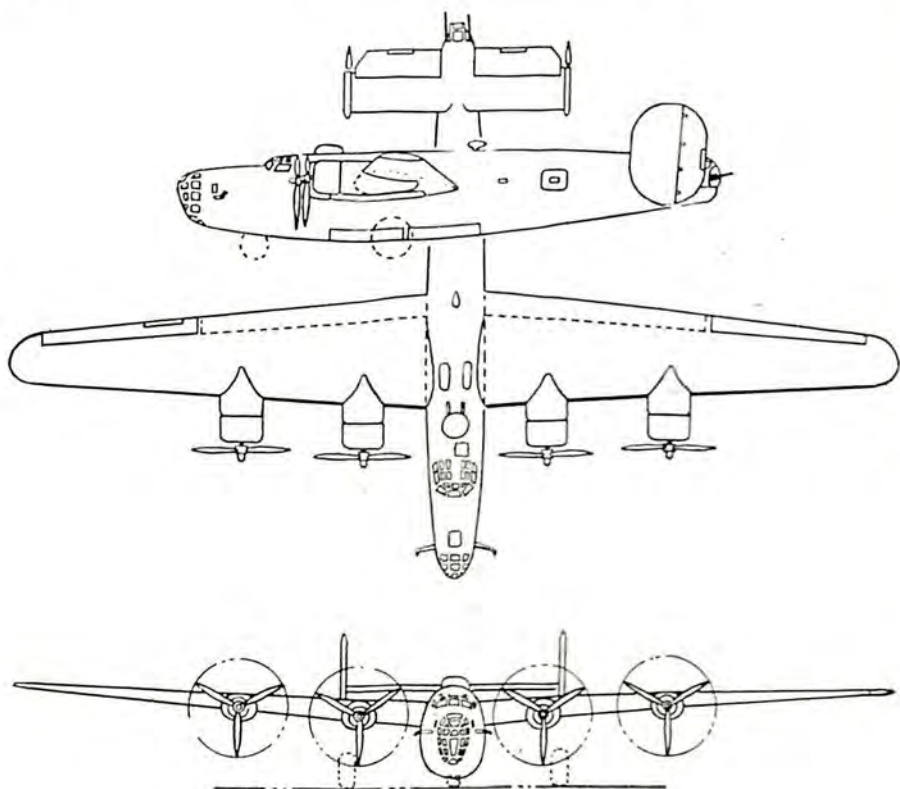

CONSOLIDATED VULTEE B-24 LIBERATOR

This Army and Navy long-range bomber was powered by four Pratt & Whitney turbo-supercharged engines rated at 1,200 h.p. each.

Commonwealth Aircraft, Inc., Kansas City, Kans., was building instrument training planes, Model 8135T, as well as gliders. Due to the large amount of war contracts, production was reduced on the Cloudster and Instrument Trainer models. The Rearwin Cloudster proved popular on Civil Air Patrol, while the Rearwin Instrument Trainers were used extensively on Civilian Pilot Training programs and for air line pilot training. The company was in production on CG3-A nine-place training gliders. Commonwealth also had a large contract for CG4-A 15-place troop carrying gliders. In the engine department, hydraulic units for aircraft companies, glider tow releases, and various ordnance items were being manufactured.

Consolidated Vultee Aircraft Corporation, San Diego, Calif., reported production step-up, construction of new airplane types, major design improvements and continued large-scale employment of women as important activities early in 1944. Consolidated Vultee reported that it had reached the top position, both in number and in weight of airplanes produced. WPB figures disclosed that Consolidated Vultee

plants in 1943 had delivered 126,000,000 pounds of airplanes, including spare parts. Of all airplanes produced in the United States in 1943, Consolidated Vultee manufactured more than 12 per cent by number and 16 per cent by weight.

The San Diego division was among the highest in production of heavy four-engine bombers, the Liberator. The Nashville division held honors in the single-engine bomber field. The Vultee Field and Stinson divisions had fine records for production of basic trainer, advanced trainer and utility transport airplanes. In the final quarter of 1943, the San Diego division delivered 8.2 pounds of heavy four-engine bombers per man per day.

In addition to record output of heavy bombers by divisions of the parent corporation, production was further augmented when the Douglas and North American aircraft corporations undertook manufacture of the model starting in February and May, 1943, respectively: The Ford Motor Company had been producing Liberators since September, 1942.

Two new models brought into production by the Stinson division of Consolidated Vultee were the Sentinel L-5, popularly known as the "Flying Jeep," and the Reliant AT-19. The Sentinel was a light, rugged, highly maneuverable craft designed for Army Air Forces reconnaissance. It was smaller than the pioneer of its type, the Vigilant L-1. The Reliant was a modification of the peace-time Reliant. In its new form it was designed to serve as a navigational trainer. It was built under direction of the Army Air Forces for assignment to the British Government, and was used for instruction of Navy flyers.

While design and installation changes were affected on all Con-



CONSOLIDATED VULTEE VENGEANCE  
The Army Air Forces A-35 dive bomber.

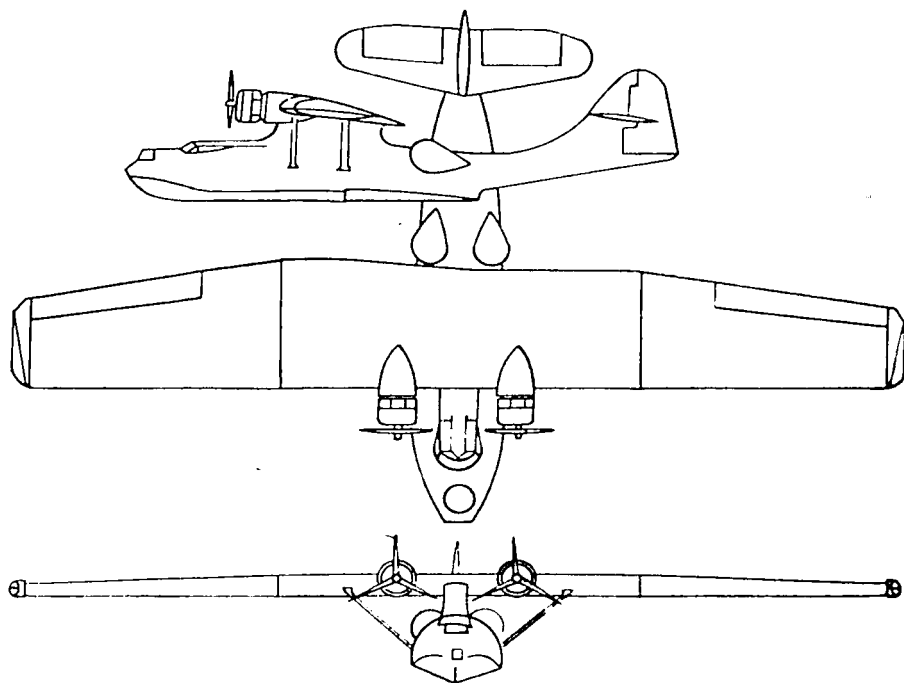

#### CONSOLIDATED VULTEE CATALINA

This long-range patrol bomber was powered by two Pratt & Whitney engines rated at 1,200 h.p. each. As a flying boat it was known as the PBV, while the amphibian was designated PBV-5.

Consolidated Vultee airplanes, major improvements were instituted mainly in the Liberator B-24 heavy bomber and the Vengeance dive bomber. Fire power of the Liberator and Vengeance were increased. Nose and belly power turrets were added to the Liberator, to give it a total of four turrets and ten .50 cal. machine guns. Heavier machine guns were installed in the wing of the Vengeance, where formerly four .30 cal. machine guns had been installed in the wing of the Vengeance, and two .30 cal. weapons mounted in the rear cockpit. Performance of the Vengeance was also improved with installation of a 1,700 h.p. Wright Cyclone engine in lieu of 1,600 h.p. Wright Double Cyclone power plant.

The Consolidated Vultee Army B-24 Liberator, also bearing the Navy designation PB4Y-1, had four Pratt & Whitney 1,200 h.p. turbo-supercharged Wasp engines, wing span 110 ft., length 66 ft. 4 in., height 18 ft. with nose wheel on the ground, gross weight over 56,000 lbs., empty weight 34,933 lbs., maximum speed at optimum altitude over 320 m.p.h., cruising at over 200 m.p.h., stalling 79 m.p.h., maximum range over 3,000 mi., service ceiling 36,000 ft. The Liberator contained 400,000 rivets, 85,000 bolts and nuts, nearly 50,000 parts made of raw materials, more than 52,000 parts which the

builders purchased and more than 30,000 additional parts supplied by the Government.

The Consolidated Vultee Catalina PBV-5 flying boat and PBV-5A amphibian, had two Pratt & Whitney 1,200 h.p. Wasp engines, a wing span of 104 ft., length 63 ft. 10 in., height 18 ft. 10 $\frac{5}{8}$  in., gross weight 35,000 lbs., empty 17,564 lbs. for the flying boat and 20,039 lbs. for the amphibian, maximum speed at optimum altitude 185 m.p.h., cruising at 125 m.p.h. at 10,000 ft. (flying boat) and 130 m.p.h. at 10,000 ft. (amphibian), maximum cruising range about 4,000 mi.

The Consolidated Vultee Coronado PB2Y-3 had four 1,200 h.p. Pratt & Whitney Wasp engines, wing span 115 ft., length 79 ft. 3 in., height 27 ft. 6 in., gross wt. 66,000 lbs., wt. empty 39,332 lbs., cruising speed 160 m.p.h., normal range loaded 2,940 mi. with 3,075 gal.

New training programs were instituted by Consolidated Vultee at its Allentown, Elizabeth City, Louisville and New Orleans divisions. Thus, complete training facilities for both in-plant and new personnel

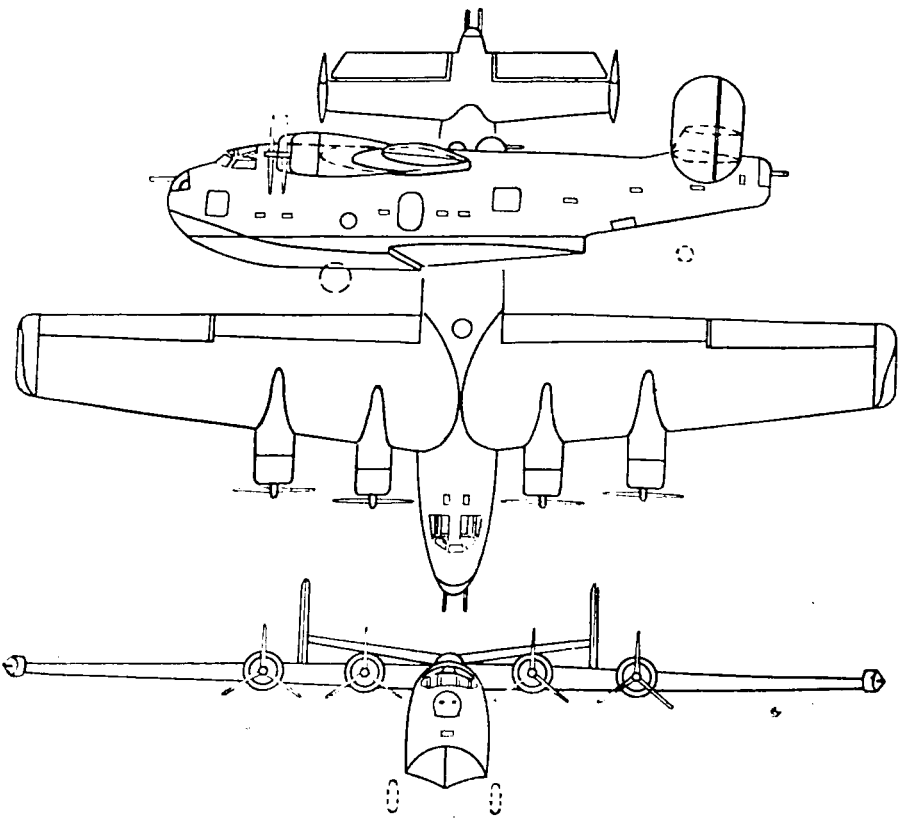

#### CONSOLIDATED VULTEE CORONADO

This Navy long-range patrol bomber, PB2Y had four 1,200 h.p. Pratt & Whitney engines.



were made available to all manufacturing and modification units of the corporation. Throughout 1943 a total of 10 per cent of all employees had been in training in the various divisions. Divisions located in areas subject to enemy action continued to train auxiliary defense volunteers, while training programs for officers and enlisted men of the armed services were carried on by the San Diego and Tucson divisions.

Curtiss-Wright Corporation, New York, had airplane divisions at peak production in Buffalo, N. Y., Columbus, O., and St. Louis, Mo. Production in 1943 had been 58 per cent higher by weight than during the previous year. The output for the first 11 months had been 40,353,352 pounds of airframes and parts exclusive of the weight of engines and other Government furnished equipment, an increase of 14,874,500 pounds. The 1943 production included comparatively few trainers but a vastly increased number of combat planes and transports. They were the P-40 Warhawk fighter, the C-46 Commando cargo transport, the SB2C Helldiver Navy dive bomber, its Army counterpart the A-25 Helldiver attack bomber, the SO3C Seagull Navy scout observation and the Republic Thunderbolt fighter.

The P-40 Warhawk retained the major structural features of earlier models but was modified to keep pace with military requirements. Changes included an improved Allison engine, enlarged rear vision fuselage cutout, slightly smaller landing gear wheels and provision for carrying auxiliary wing gasoline tanks or additional bombs. The power plant was an Allison V-1710 12-cyl. liquid-cooled engine with a Curtiss three-blade electrically controlled, multi-position constant speed propeller, with ventural glycol and oil radiators beneath the engine, and a controllable exit. The Warhawk had an enclosed pilot's cockpit with a sliding canopy and facilities for heating and ventilation. The fighter had a wing span of 37 ft. 4 in., length 33 ft. 4 in. and height 10 ft. 7 in. It weighed about 9,000 lbs., and had a stated speed of more than 350 m.p.h., ceiling over 30,000 ft. and range of about 1,000 mi.

Up to November 30, 1943, Curtiss-Wright had produced more than 10,000 P-40 fighters, including the Hawks 81 and 82 supplied Great Britain. It was a very popular plane in the combat theaters of North Africa, China and Burma. The builders after a survey of 50 combat engagements by the P-40 announced a box score of 12½ enemy planes shot down for every P-40 destroyed. In those 50 combats the P-40's downed 420 enemy planes and lost only 31, although the P-40 was outnumbered 1,257 to 457. In January, 1943, 22 P-40 fighters flew a record non-stop flight for single engine planes—1,300 miles from Midway to Honolulu in 6½ hours.

The Curtiss Commando was the largest two engine transport in production early in 1944. It had two Pratt & Whitney 2,000 h.p. twin-row Wasp engines with a two-speed blower and Curtiss Electric

constant speed, fast feathering four-blade propellers. It had a wing span of 108 ft. 1 in., length 76 ft. 4 in., height 21 ft. 9 in., and wing area, including flaps and ailerons of 1,360 sq. ft., weight 50,000 lbs. maximum, stated speed over 250 m.p.h., ceiling over 25,000 ft. and tactical radius 800 mi. The cabin was divided into two levels. The main compartment had 2,300 cu. ft. of space, the lower forward cargo had 197 cu. ft. and the lower rear cargo 258 cu. ft.

During the Spring of 1943 a fleet of Army Commandos made the longest mass flight on record, flying more than 14,000 miles and carrying more than 90 tons of critical cargo, besides important personnel from the United States to India. The vanguard of this fleet made the trip in four and a half days, and the entire fleet completed the mission in about a week.

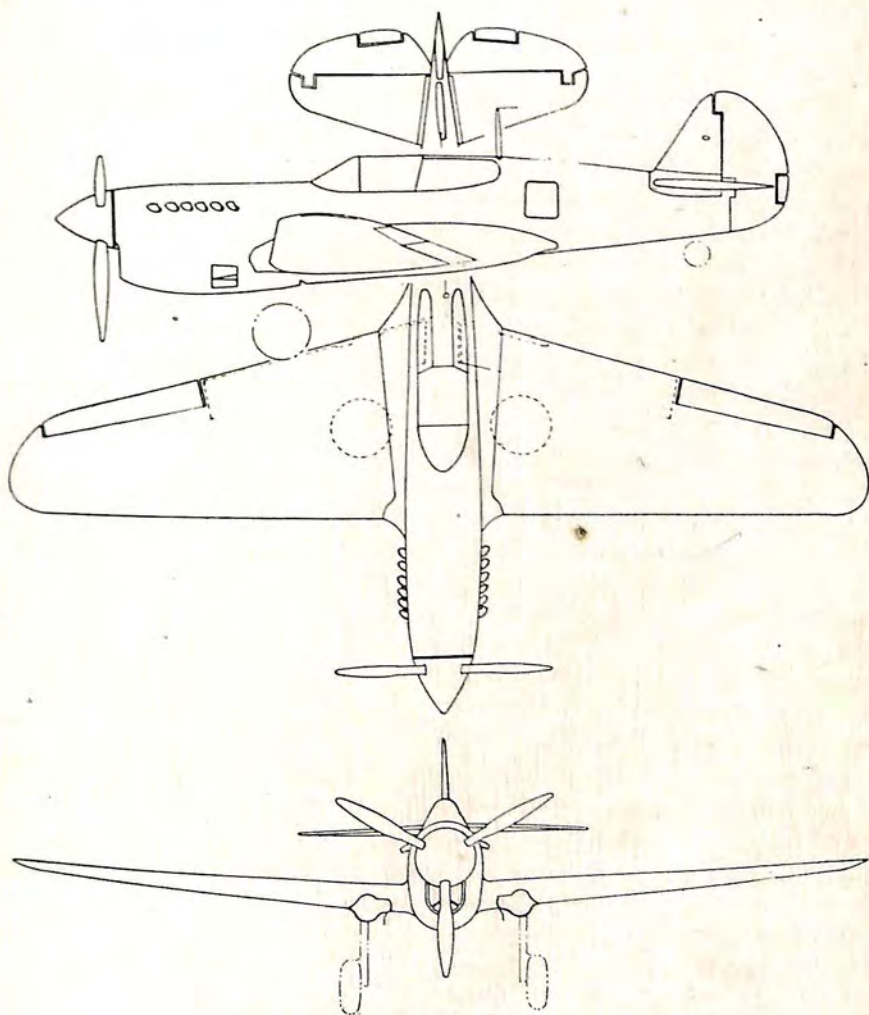

CURTISS WARHAWK



One of the largest transport production projects ever set up was that of the Army Air Forces program for C-46 Commandos to be built by Curtiss-Wright and Higgins Aircraft.

Curtiss-Wright airplane employees totaled about 86,000 of whom 38 per cent were women. Women doing shop work were about 37 per cent of the total. More than 12,000 men and women left the plants to serve with the armed forces. Expansion of plant facilities, begun in 1940, continued throughout 1943, bringing the total to 8,608,209 sq. ft., an increase of more than a million over 1942. The Buffalo plants totaled 3,452,955 sq. ft., an increase of 137,385 sq. ft.

The Curtiss-Wright plant at Columbus, O., was in production on the new Helldiver dive bomber and the SO<sub>3</sub>C Seagull scout observation plane. The Seagull seated two and had either land gear or a main float and wing tip floats for catapult operations. It was powered by a Ranger 520 h.p. V770-6 12 cyl. aircooled engine and a two-blade Hamilton Standard constant speed propeller.

The Helldiver distinguished itself with remarkable success in the attacks on Rabaul, during the offensive which started on November 11, 1943. The Helldiver incorporated 889 major changes between July, 1942, and November, 1943. They included a full-enclosed fuselage bomb load, combination bomb load of one giant bomb or two bombs of half the weight, mechanically operated wing tip slots for good lateral control at low speed, large split flaps for speedy bomber braking control in attack dives, and a series of secret improvements. The Navy Helldiver had its counterpart in the Army A-25. The power plant was a Wright 14 cyl. double row Cyclone with three-blade Curtiss propellers. The Helldiver carried machine guns in the wings and rear cockpit turret. It was used with telling effect by the squadrons of Naval Aviation and the Marine Corps against the Japanese in the Pacific campaigns.

The Army Helldiver was in production at the Curtiss-Wright plant in St. Louis which also had an increasingly heavy program for the Commando cargo transport. The St. Louis plant had built the first C-46, which was the peacetime prototype of the Army cargo transport. The commercial ship had been designed as a luxury airliner carrying 36 persons. Its importance to the Army was made apparent by the huge production orders for the Curtiss-Wright plants in Buffalo, St. Louis and Nashville, Tenn., and the Higgins plant in New Orleans.

Production shortcuts played a major part in keeping a full production quota of Warhawks and Commandos rolling off the assembly lines of Curtiss-Wright plants in New York State. In the press and cutting departments, 50 per cent of the handling time was eliminated through the installation of a conveyor operating from the shearing machines, to the routers, to high-speed drills and to uni-shear. In the machine shop, landing gear oleo struts were produced more efficiently

through the use of a straight-line, roller-type conveyor which eliminated 30 per cent of the operations. In the salvage department, where floor sweepings and scrap stock were baled and pressed for transportation to a reclamation plant, installation of a conveyor system slashed handling and costs by nearly 50 per cent.

Through the use of specially designed precision wing assembly jigs, manual handling was eliminated and wing assemblies moved down the production lines every 40 minutes, insuring accurate wing construction at top speed. Dollies equipped with V casters carried P-40 fuselages along the tracks from the first production station, past work stations and part bins and ending up in final assembly where completed subassemblies of the P-40 emerged on similar spur tracks to join the fuselage and make up the complete aircraft.

Plastics played a great part in production. A spectacular develop-

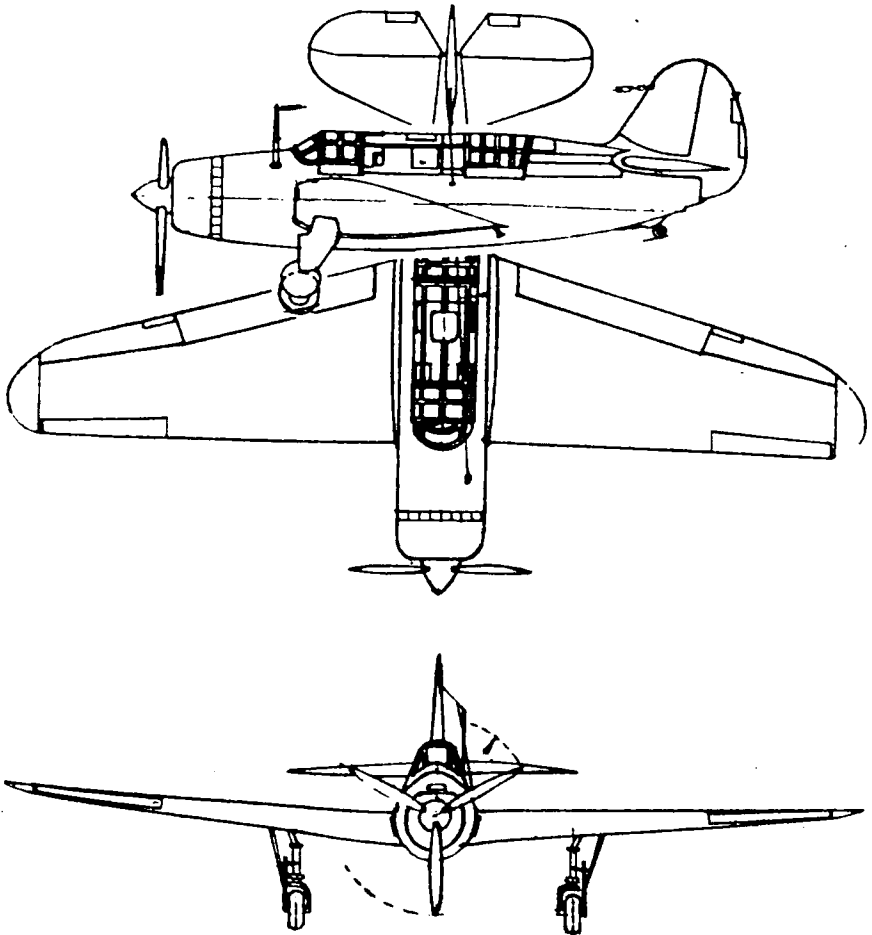

CURTISS HELLDIVER

A Navy dive bomber, designated as the SB<sub>2</sub>C.

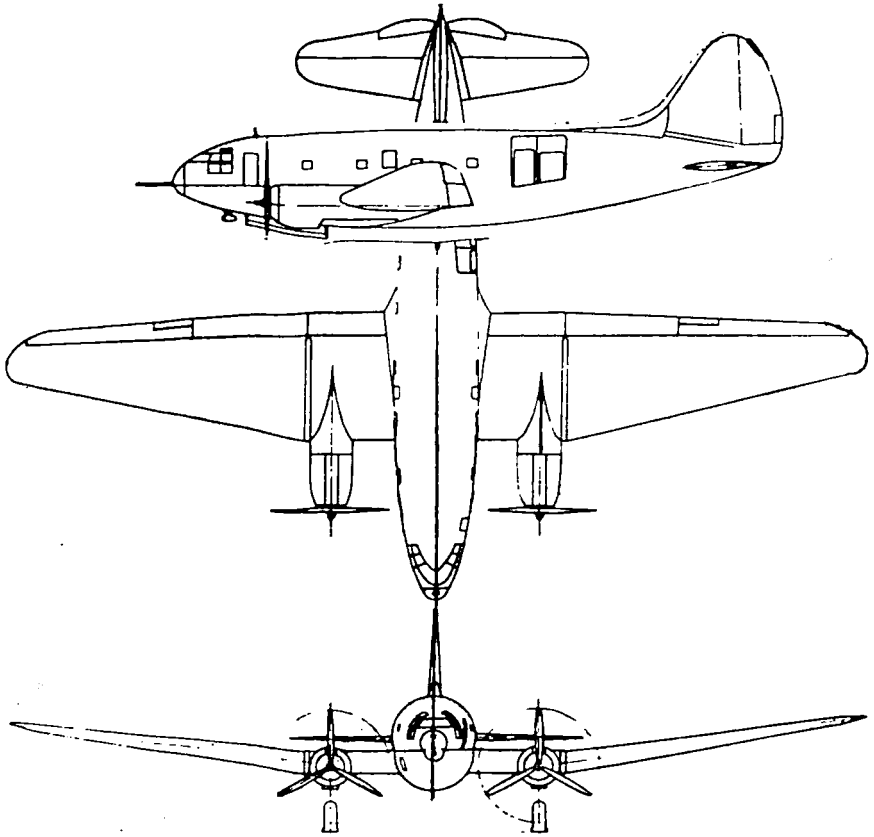

CURTISS COMMANDO

The C-46 Army cargo transport.

ment in plastics was the production of a 1,000 pound casting measuring 13 ft. long and 3 ft. wide. This experiment was conducted to probe the possibilities of thermosetting plastics as a replacement for steel. It formerly required four hours to process a metal part used on the C-46 Commandos. The introduction of a plastic substitute made possible the same part's production in three minutes. Some of the complex air scoops for the P-40 required more than a week of three-shift effort to produce. The same quantity was made in 16 hours, and the air scoops were better. Ingenuity of Curtiss-Wright workers helped cut down man and machine hours in sizable savings in cost and increased warplane production.

To assure the health and well-being of the workers, Curtiss constructed modern clinics and hospitals in the Buffalo plants, with 24-hour medical service, a staff of 12 doctors, 50 nurses, and three x-ray and laboratory technicians. Equipped with modern surgical and medicinal supplies, the hospital could take care of illnesses and in-



juries ranging from the common cold to major operations. At the airport plant the operating room and clinic were subterranean and bomb proof, and were lighted by a separate power system. Three ambulances were on constant alert, ready for any emergency.

A vast airplane hangar, built in cooperation with the Army for the purpose of servicing and repairing all types of aircraft after production, was erected and put in operation adjacent to the airport plant. Rated one of the largest modification centers in the country, important modifications were made on many types of military aircraft.

The Army Air Forces and Curtiss-Wright erected and maintained Camp Curtissair, where enlisted men were taught important P-40 and C-46 groundcrew duties. The camp centered around the modern administration building where classes covering all phases of P-40 and C-46 maintenance work were conducted. The instructors were trained by Curtiss-Wright which planned all the classroom mock-ups and curriculum. The AAF and Curtiss worked closely together in teaching these enlisted groundcrew men the technicalities involved in servicing fighting P-40s and C-46s.

Douglas Aircraft Company, Santa Monica, Calif., continued to produce one-sixth of all the nation's planes, by structural weight—a production miracle that was accomplished despite an acute shortage of trained aircraft workers, the loss of many hundreds of experienced employees to the armed services, the necessity of employing women for approximately 50 per cent of all production work and an unprecedented labor turnover. Production during 1943 had been concentrated on the four proven Douglas models—the SBD Dauntless dive bomber, the A-20 Havoc attack bomber, the C-47 Skytrain Army transport, all pre-war models, and the C-54 Skymaster combat transport, which was on the production line when we entered the war. In addition, because of company experience in big plane production, Douglas was building an important share of the output of Flying Fortress and Liberator four-engine bombers.

Production figures on the C-54 Skymaster were secret; but it could be said that the huge plant built in Chicago by the Government for the manufacture of this model had been in production since July, while the output from the Santa Monica plant had continued without interruption.

The Dauntless dive bomber at the end of our second year of active warfare was the only dive bomber being flown from the decks of American carriers in combat. During that period it had completed an oceanwide circle of devastating attacks against enemy bases, starting with the Gilbert Islands on February 1, 1942, and ending with the capture of those fortified outposts by American carrier task forces late in 1943. The battle record of the Dauntless was as follows: Salamaua and Lae, 12 enemy vessels sunk or disabled; Tulagi Harbor, 14 enemy vessels sunk; Coral Sea, 2 aircraft carriers sunk, a

third knocked out of action and a heavy cruiser sunk; Midway, 4 carriers put out of action with all their planes, 2 battleships, 3 heavy cruisers and one light cruiser badly damaged; Eastern Solomons, one carrier, one battleship, one light cruiser and one transport sunk; battle of Guadalcanal, one battleship, one heavy cruiser and one light cruiser probably sunk, 4 heavy cruisers and 9 troop transports sunk, one light cruiser and 21 troop transports badly damaged. Over and above sinkings and damage credited to them in the Eastern Solomons and the Guadalcanal naval-air engagements, Marine Corps pilots flying Dauntlesses also sank 2 Japanese destroyers and 8 cargo ships, probably sank 5 destroyers and damaged 20 destroyers during the occupation of Guadalcanal.

On our northward movement through the Solomons toward Rabaul, Dauntlesses were employed in most of our attacks against enemy naval forces and bases in the Solomons: and they likewise comprised all dive bombing units employed in our carrier task force campaign against Jap bases in the western and central Pacific, which started with the Marcus Island raid of September 1, 1943, and culminated in the capture of Tarawa, Makin and other islands of the Gilbert group.

In the European theater, Dauntlesses opened our North African invasion, dive bombing and silencing the guns of the French battleship, Jean Bart, at Casablanca, bombing submarines, hostile ships and shore batteries at El Hank, and bombing and strafing the harbors, roads and troop concentrations at Casablanca, Port Lyautey and Fedals. They were similarly employed in the Sicilian and Italian invasions.

The Douglas A-20 Havoc attack bomber had a fine record. Both Britain and Russia received thousands of Havocs and China was preparing to manufacture them for use against Japanese invaders in 1944.

While wholesale deliveries to our allies limited the numbers in service with our own Army Air Forces, the Havoc which delivered the first American blow against occupied Europe on July 4, 1942, participated in every American campaign up to the end of 1943. Havocs were our first interceptors at Guadalcanal. They spearheaded the American-Australian attack that drove the Japs back across the Owen Stanley Mountains in New Guinea. They then participated in the daily attacks against Jap strongholds on the north coast, helping reduce Buna, Salamaua and Lae to rubble and aiding their capture by allied troops. They took part in the battle of the Bismarck Sea, "skip bombing" enemy vessels from shipmast height.

In Tunisia, A-20 Havocs flew thousands of sorties, many planes making three missions a day, flying from bases and fields just behind our ground forces and strafing enemy troops and supply trains, busting tanks, exploding munition dumps and setting fire to gas stores.

While Russia made no report on the work accomplished by thousands of A-20s which she was using for troop support, the R.A.F.

credited the plane, which they called the Boston, with a substantial share in winning the battle of Britain.

The Douglas C-47 Skytrain transport—the military counterpart of the DC-3 of air line fame—distinguished itself as greatly as did Douglas bombers. Twice it was credited by high military officials with turning the tide of battle and saving our most important beachheads from obliteration. In Guadalcanal they flew in the vital munitions and aviation fuel that saved our occupational forces from defeat on two different occasions. At Salerno, in a period of 45 minutes, they dropped 2,600 paratroopers at a point where they were able to turn the enemy flank when we were in danger of losing our beachhead. They saved the lives of many thousands of soldiers and marines by flying blood plasma to the front lines and evacuating the desperately wounded who were in urgent need of operative care and could not have

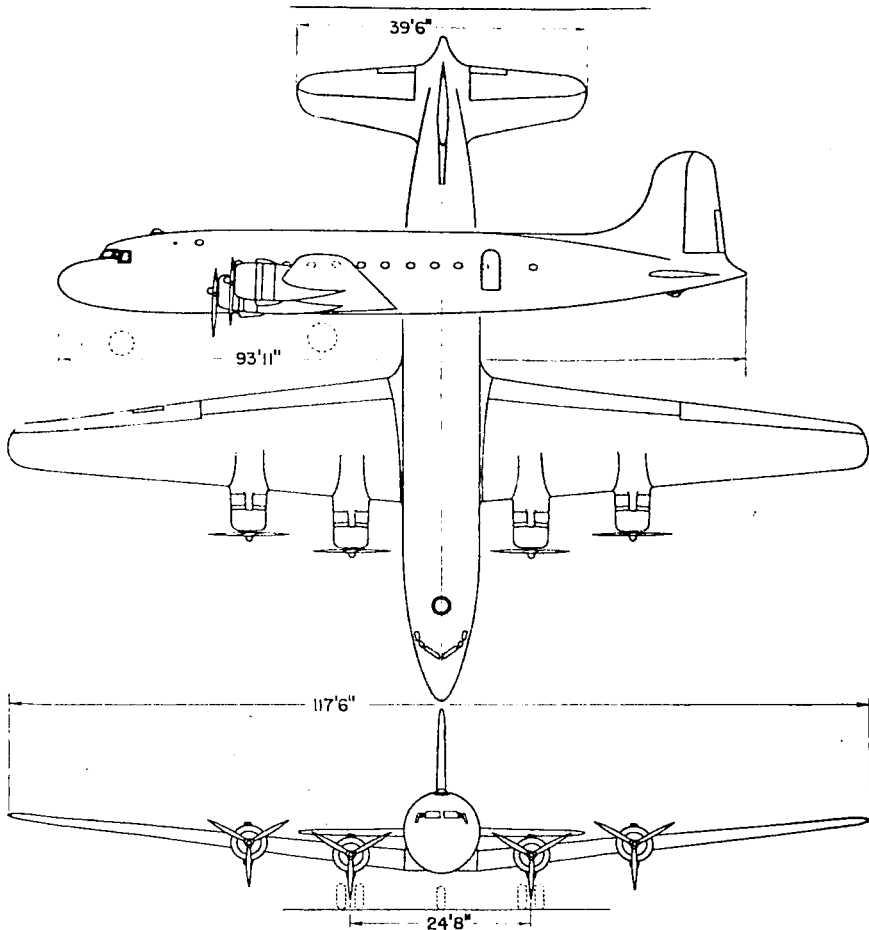

DOUGLAS C-54 SKYMASTER ARMY TRANSPORT

survived the strain of transport by other means. The C-47s were sole equipment for the Troop Carrier Command and as such flew out the great majority of more than 100,000 casualties evacuated from the various fronts between December 7, 1941, and October 1, 1943. Brig. General F. S. Borum of the Air Transport Command has stated, "all patients who were evacuated from forward stations to base hospitals during the Tunisian campaign were flown out in Troop Carrier Command-operated Douglas-built aircraft, and the same thing holds true in the other theaters of war where thousands upon thousands of injured have been saved by air evacuations."

Douglas DC-3s, flown commercially by Pan American Airways, broke the Axis air line hold on the economic life of South America, and cleared the way for our State Department to unite nearly all those nations with us. DC-3s were next used by Pan American's CNAC to evacuate more than 7,000 refugees from Burma, after which this plane and its military counterpart created an aerial Burma road, flying in to China in 1943 as great a volume of strategic materials per month as was ever carried in trucks over the captured surface route.

Douglas transports flew from Australia to Port Moresby the 3,800 troops which drove the Japs back across the Owen Stanley Mountains; and then flew to the north coast of New Guinea an army of 7,000 men which they continued to supply and provision. They were operated by SCAT, and flew 1,000 trips to Guadalcanal with vital supplies and carried back thousands of wounded.

In the Tunisian campaign, C-47 Skytrains flew an aggregate of a million pounds during the battle of Kasserine Pass, carrying forward the munitions which permitted our forces to beat back the enemy's most dangerous break-through. They then carried paratroopers to spearhead the invasion of Sicily, a work which they continued with vital effectiveness in the Italian campaign.

Limited before Pearl Harbor by CAA regulations to a gross load of 26,500 pounds, these planes were flown regularly by Army, Navy and Marine Corps pilots at grosses running between 28,000 and 31,000 pounds. They were built only as land planes, but were flying the oceans every day.

In its first year of flying war materials to our most distant battle-fronts, the Douglas C-54 Skymaster transport earned recognition by American experts as a practical transport for commercial air line operations after the war. More than twice as big and half again as fast as the DC-3, the Skymaster not only commenced to shoulder the United Nations' long-range air transport burden, but it also was chosen to transport on foreign missions practically all the officials responsible for the conduct of the war.

In daily scheduled service over both oceans, the Skymaster was capable of carrying a normal payload of 20,000 lbs. a distance of 1,500 miles non-stop. Equipped with 54 hospital litters, it had rushed

loads of wounded a distance of 10,000 miles in five days. It also brought from distant points, cargoes of vitally needed war materials, such as tungsten, bristles, silk, tin, mica and industrial diamonds. On a maiden flight from San Francisco to Brisbane, carrying a capacity load of vitally needed airplane parts that were too big to fit into any other airplane, the C-54 established records of 35 hours flying time and 39 hours elapsed time, making only two stops and maintaining an average speed of 202 m.p.h. Its maximum speed was 285 m.p.h. and cruising speed 225 m.p.h.

New orders, resulting from the Skymaster's steady record of dependable service, increased the company's backlog for this plane to more than \$300,000,000; and the entire production capacity of the

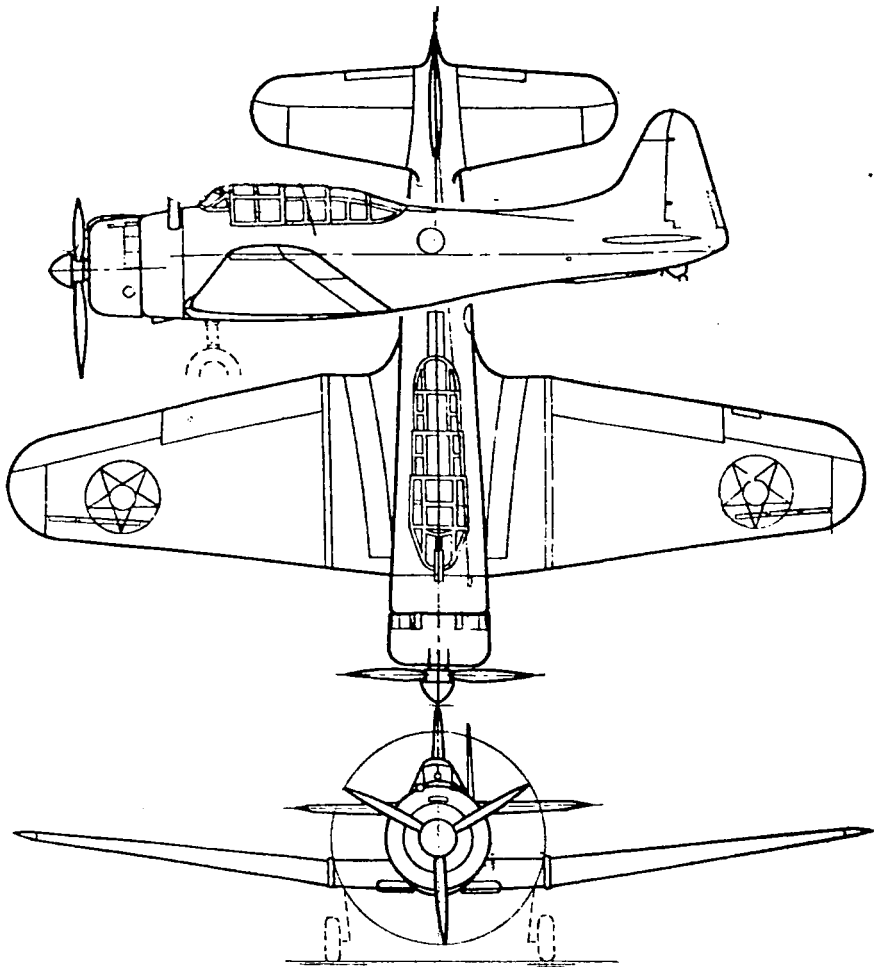

DOUGLAS SBD-3 and A-24

The SBD-3 was the Navy version and the A-24 was for the Army Air Forces.



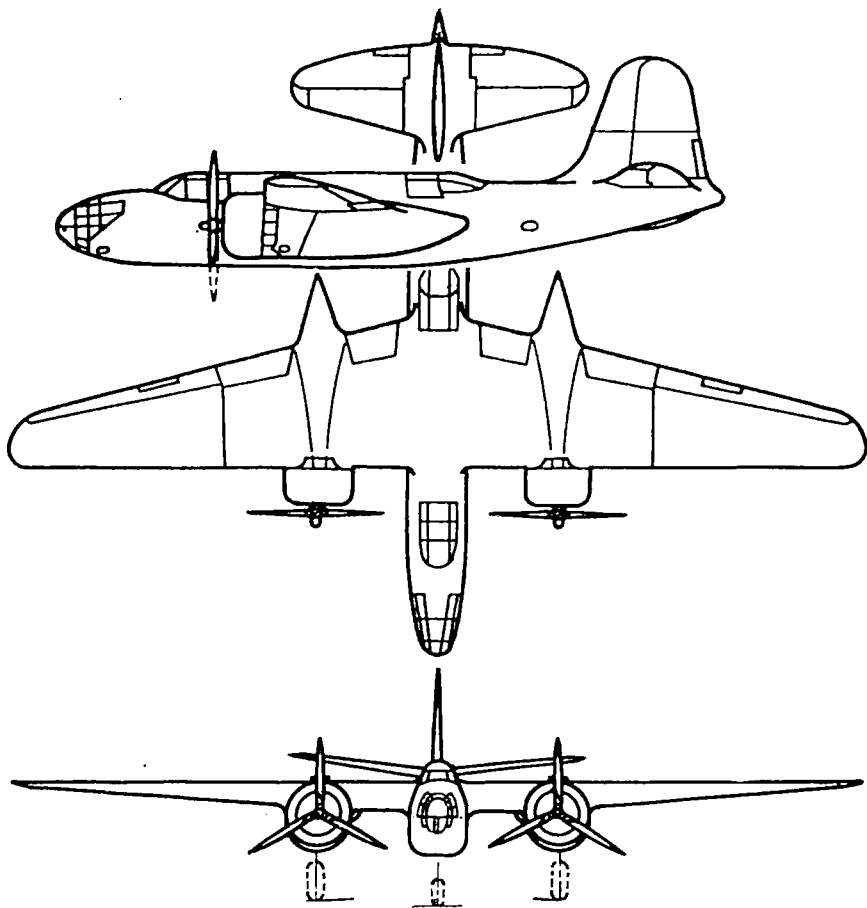

DOUGLAS DB-7B—BOSTON

Douglas Chicago plant as well as the original assembly line at Santa Monica, was being devoted to its manufacture early in 1944.

Douglas reported more than 150,000 employees in all plants. Douglas employees increased salvage of vital materials by 800 per cent and held absenteeism at the low figure of 6 per cent despite constantly increasing employment of older men and women.

Fairchild Aircraft Division of Fairchild Engine and Airplane Corporation, Hagerstown, Md., stepped up production of its PT-19 trainer and UC-61 utility cargo airplanes. The bulk of Fairchild's productive capacity was concentrated on those two models, both of which were revised in 1943. The PT-19A Cornell Army trainer was modified to include night flying equipment, battery and generator, and was designated as the PT-19B. Because of a change in the training program, later in the year, production on the PT-19B was stopped and that on the PT-19A resumed. The UC-61A, wartime version of

the four-place F-24 and known as the Forwarder, was redesigned around the 200 h.p. Ranger inverted inline engine and the prototype designated as the UC-61K. At the beginning of 1944, this new model was undergoing engineering flight tests, preliminary to early production.

Concurrent with production of trainers for our air forces, the Fairchild PT-26 Cornell trainer was manufactured for use by the Royal Canadian Air Force and Royal Norwegian Air Force by Fairchild in Hagerstown and by Fleet Aircraft in Canada. Manufacture of the PT-19A by the Brazilian Aeronautical Commission under Fairchild license in South America was begun for the Brazilian Air Force. Those airplanes were powered by Ranger engines assembled in Brazil.

The Fairchild XAT-14, a bombardier trainer developed from the XAT-13 which was a bomber crew trainer, was modified to a gunnery trainer known as the Gunner and designated as the AT-21. The new model, which was made primarily of wood and molded plywood by the Fairchild Duramold process, was placed in production at the Burlington, N. C., branch plant of Fairchild Aircraft Division. Several units were completed and delivered in 1943. In 1944, the plant was in full production on that model. The same plane was under construction at the Memphis, Tenn., plant of McDonnell Aircraft Corporation, St. Louis, Mo., and at Bellanca Aircraft Corporation, New Castle, Del. under Fairchild license agreements. Engineering and production information was coordinated through a special committee including representatives of the Army Air Forces, Fairchild and the other contracting companies, with committee headquarters in Hagerstown.

Construction of the prototype of the Fairchild cargo plane, C-82, was begun at Hagerstown. An addition was built to the final assembly plant, in which a "pilot line" of cargo planes was to be produced in 1944. To determine accurately loads and stresses on various structures of the new model, and to evaluate properly the qualities of sub-



THE FAIRCHILD AT-21 GUNNER

A gunnery crew trainer constructed of wood and molded plywood by the Fairchild Duramold process, and powered by Ranger engines.

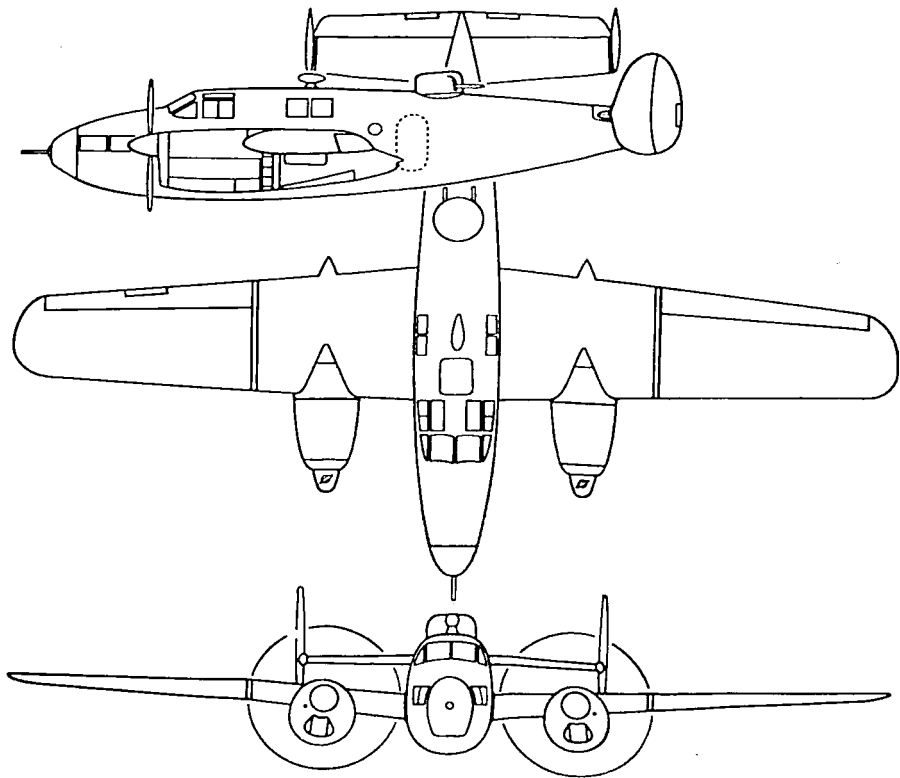

THE FAIRCHILD AT-21 GUNNER

stitute raw materials for all types of production, an enlarged testing laboratory was set up in one of the Hagerstown plants. It was equipped with the latest testing devices and machines of all types. Much of the detailed engineering work on the cargo plane was accomplished in a branch engineering office located in New York and staffed by men specially trained in aircraft by Fairchild.

Production of metal wing panels for the Martin Navy PBM-3 Mariner patrol bomber and for the Martin A-30 Baltimore attack bomber for the R.A.F. was continued throughout 1943 at Hagerstown. In addition to wing panels, Fairchild also assembled and finished a large quantity of rudders, elevators and ailerons for the Baltimore.

Successful use of a large number of buildings throughout the city was known as the Hagerstown System. Fairchild extended the system to include six more plants, bringing its total to 29. Buildings which might otherwise have remained idle for the duration of the war thus provided space for the manufacture of detailed parts and for sub-assembly work and warehousing. This plan served as a safeguard against the danger of over expansion and also proved to be efficient despite the scattered nature of the operations involved.

A large all wood flight test hangar was constructed. It could house 35 Cornell trainers, had complete shop facilities, flight test engineering, inspection and A.T.C. offices, as well as conference quarters and rest rooms for ferry pilots. The building was constructed of laminated wood arches with a clear span of 172 feet.

Fleetwings Division of Kaiser Cargo, Bristol, Pa., built a quantity of basic trainers, BT-12, their own design, for the Army Air Forces during 1943. The airplane had a wing span of 40 ft., was 29 ft., in length, and was powered by a Pratt & Whitney 450 h.p. Wasp engine. The bulk of Fleetwings production, however, continued to be the manufacture of surfaces such as rudders, wings, elevators, ailerons, fins and stabilizers for military airplanes, including the B-17, A-20, P-47, F4U, TBF and SB2A. In addition, the company continued to make hydraulic valves for aircraft.

In March, 1943, all stock of Fleetwings, Inc., was purchased by the Henry J. Kaiser interests.

General Aircraft Corporation, Astoria, Long Island, N. Y., con-

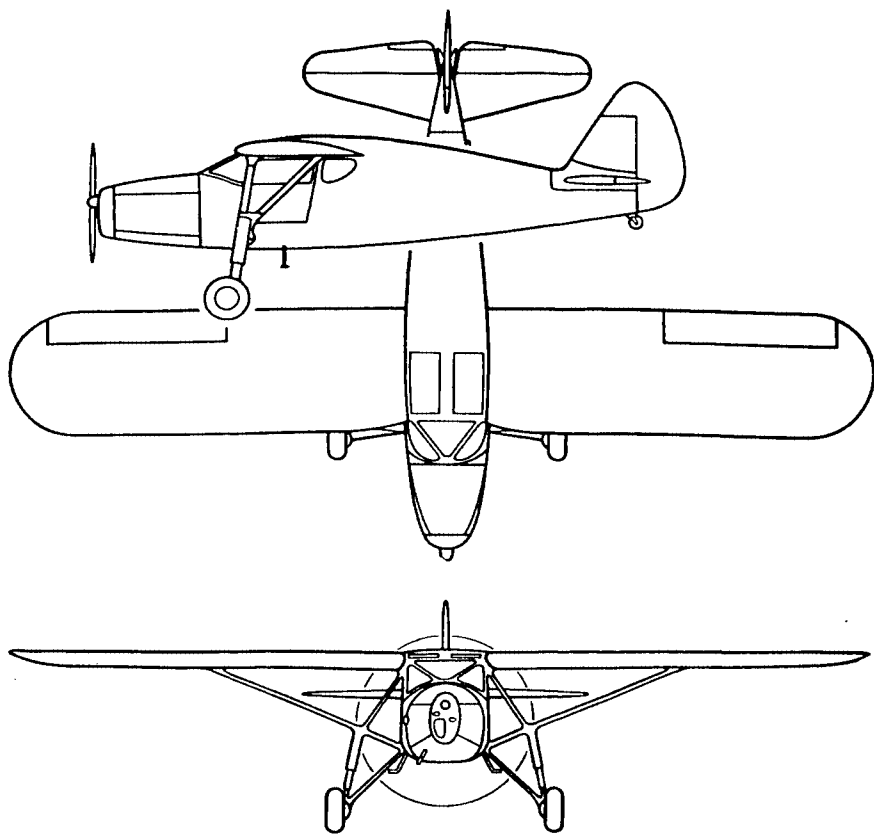

THE FAIRCHILD UC-61K FORWARDER

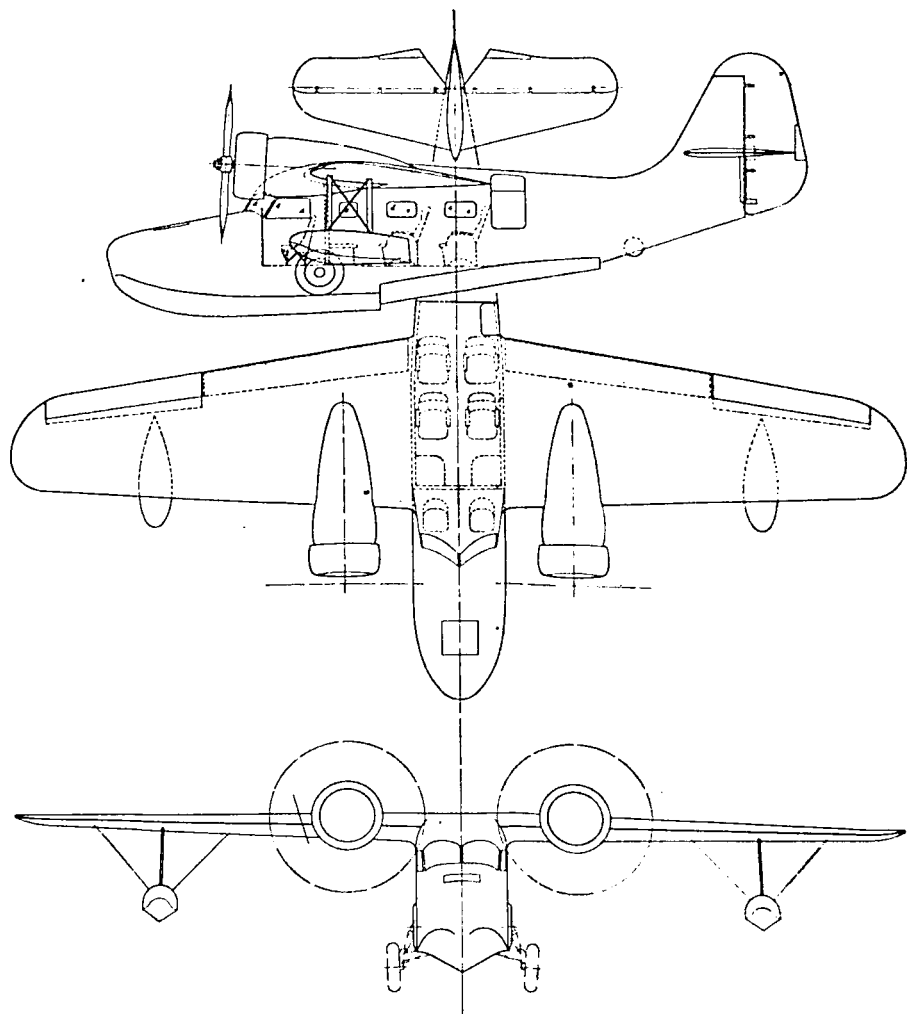

### GRUMMAN GREY GOOSE

The JRF-5 and JRF-6B. An eight-place utility amphibian and navigational trainer for the Navy air forces and Fleet Air Arm powered by two Pratt & Whitney Wasp Junior 400 h.p. engines.

tinued as one of the largest producers of the CG-4A cargo and troop carrying gliders for the Army Air Forces. Many production improvements were developed during the year. In addition to crated deliveries for expert shipment and flyaways from its Long Island plants, General Aircraft also established field crews for delivery and assembly of gliders at various airfields and a large number of gliders were assembled at distant points. Experimental work for the glider division which resulted in some improvements in the landing skid assembly and



some additional innovations in the use for which the gliders could be put was carried out. Notable among these was the design of a small trailer which could be carried in the glider. The trailer could carry a complete small machine shop or other equipment for use in the field. The Tennessee Aircraft Corporation, of Nashville, Tenn., acquired by General, in 1943, was a subcontractor producing aluminum alloy aircraft components.

Grumman Aircraft Engineering Corporation, Bethpage, Long Island, N. Y., was in production on four different models of military aircraft. The Grumman F6F-3 Hellcat was developed and put into production early in 1943, and it constituted the greater part of the company's output. It was a successor to the Wildcat which had a splendid record of combat as a Navy carrier-based fighter. The Hell-

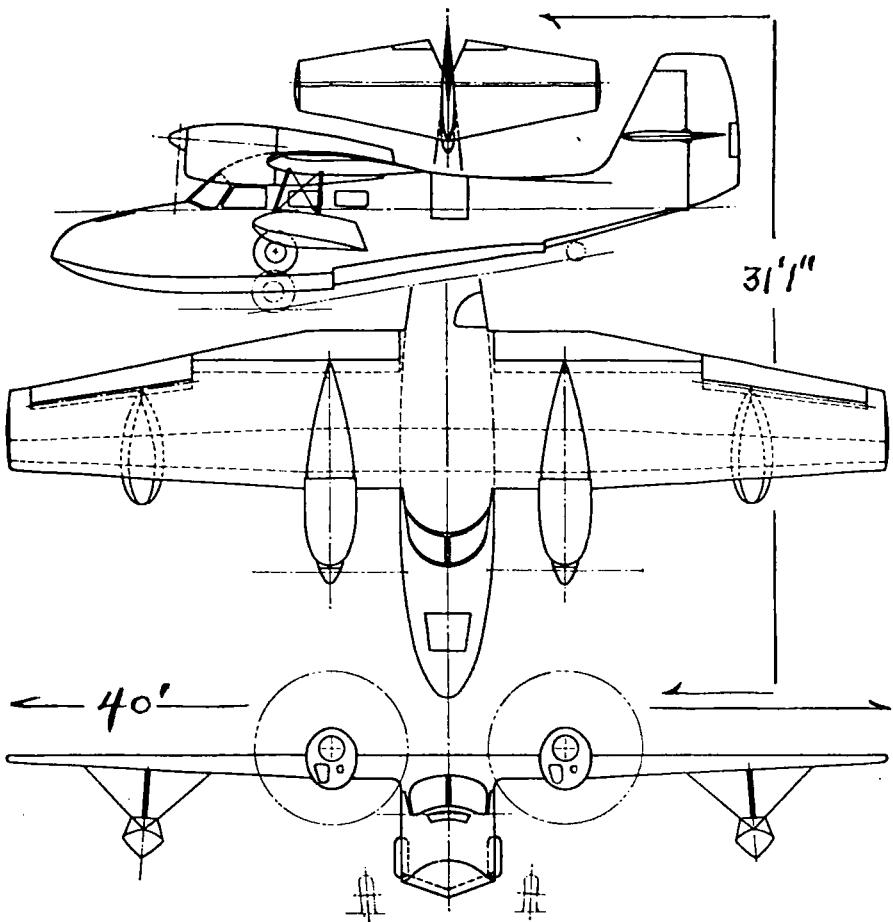

THE GRUMMAN WIDGEON

A five-place amphibian for the U. S. Coast Guard and U. S. Navy.

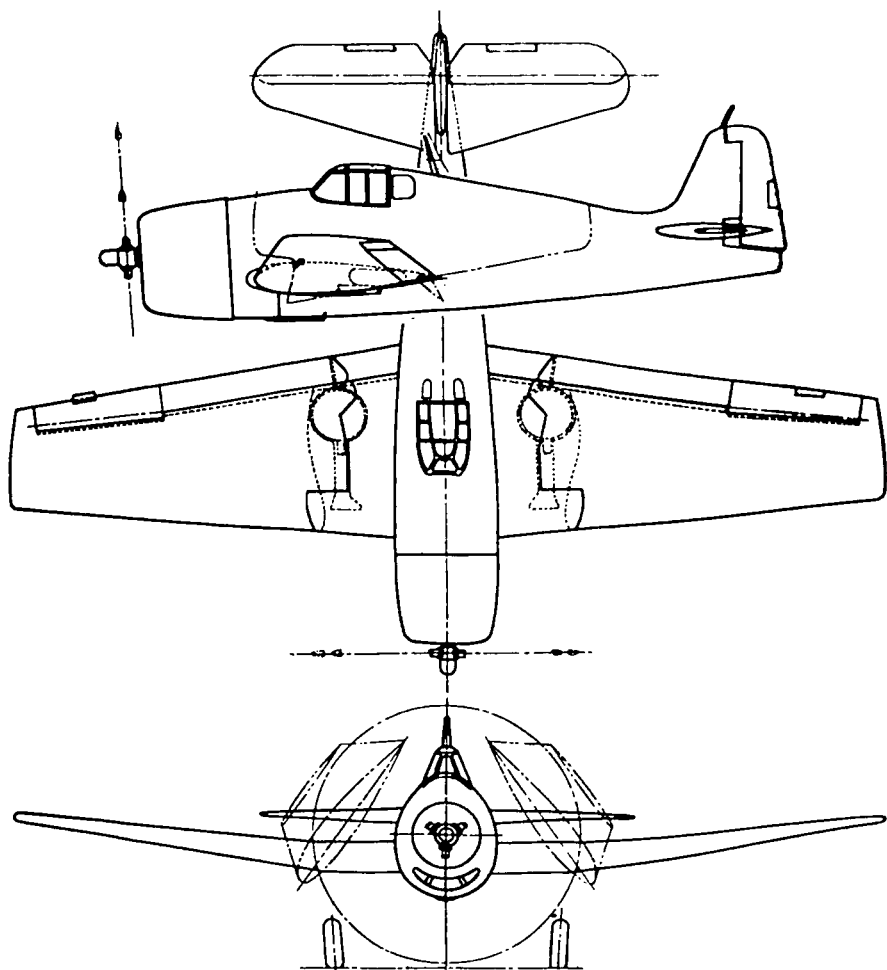

THE GRUMMAN F6F-3 HELLCAT

cat was developed from ideas brought back by Grumman engineers from the Pacific theaters where they had made extensive surveys among the pilots who flew the combat planes in some of the toughest aerial fighting of the war against the Jap. The Hellcat had a wing span of 42 ft. 10 in., and length of 36 ft. 6 $\frac{5}{8}$  in., more power, more speed and a faster rate of climb. It was in the 400 m.p.h. class. It first saw action in September, 1943, and proved vastly superior to the best planes that the Japs could send up against it. The Hellcat had the typical Grumman folding wing, permitting the plane to be stowed in the smallest possible space on a carrier.

The Grumman TBF-1 Avenger Navy torpedo plane had a long record as one of the most versatile and useful planes in service. It played an important part in many of the major battles in the Pacific,

where it operated both from carriers and land bases. It was one of the most deadly effective planes used against the Japanese Navy in every battle, and it had a long list of sinkings to its credit during the Guadalcanal campaign and the ensuing battles for possession of the islands in the Pacific. While designed primarily as a torpedo plane, the Avenger also was used extensively for horizontal bombing, dropping depth charges, long-range scouting, strafing and laying smoke screens. Its superior range for a carrier-based plane, and its folding wings for compact stowage made it one of the most popular planes in the Fleet. The British Navy also used Avengers. During the anti-submarine campaign in the Atlantic, Avengers, flying from small American escort carriers and carrying all destructive devices including depth bombs, had to their credit a large percentage of the German U-boats sunk.

The Grumman J4F-2 Widgeon was a utility amphibian used principally by the Navy and Coast Guard for coastal patrol. It carried a depth charge, for anti-submarine work, besides other weapons. The Widgeon had two Ranger 6-cyl. 200 h.p. engines, carried a crew of five, had a wing span of 40 ft., length 31 ft., height 9 ft., wing area 245 sq. ft., power loading 11.25 lb. h.p., wing loading 18.37 lb. sq. ft., weight empty 3,075 lbs., useful load 1,425 lbs., gross weight 4,500 lbs., max. cruising speed 138 m.p.h. and ceiling 15,000 ft.

The Grumman JRF-5 Grey Goose was a utility and patrol amphibian used by the Navy, Army Air Forces and Coast Guard for operations in remote regions inaccessible to land planes, for submarine patrol, photography, light cargo, personnel transport and rescue missions. It was larger than the Widgeon, had a wing span of 49 ft., length 38 ft. 4 in., height on wheels 12 ft., wing area 375 sq. ft., gross weight 8,000 lbs., empty weight 5,600 lbs., useful load 2,400 lbs., cruising speed at sea level 171 m.p.h., max. speed at 5,000 ft. 201 m.p.h. and service ceiling 22,000 ft.

Higgins Aircraft, Inc., New Orleans, La., was incorporated under the laws of the State of Louisiana November 1, 1942, and was at that time given a contract to construct a large number of Curtiss designed C-76 cargo airplanes. In February, 1943, an agreement was reached with the Defense Plant Corporation for the construction of a large airplane factory, plywood mill, saw mill and other facilities. By the end of September, 1943, the factory was completed, but in August, 1943, the Army Air Forces decided to cancel all contracts for the construction of the Curtiss C-76, and Higgins Aircraft was given a contract to construct for the Army Air Forces a large number of C-46 Commando all metal cargo transports. In addition they received a sub-contract from Curtiss-Wright for construction of a large number of wings for the same airplane. By the end of 1943, tooling, organization, and acquiring of competent personnel were well under way. In addition, Higgins Industries, Inc., the parent company, was engaged in

the design and construction of a helicopter which had been flown successfully before the end of the year.

Howard Aircraft Corporation, Chicago, Ill., was manufacturing its own plane exclusively and adapting it for two different Navy uses. A Navy contract was divided between an instrument trainer known as the NH-1 and an ambulance plane known as the GH-2.

Kellett Aircraft Corporation, Upper Darby, Pa., at the end of 1943, was completing its 15th year of aircraft manufacturing, having been continuously active since early in 1929 in the production and development of rotary-wing aircraft and as an aircraft parts subcontractor. A large proportion of the production was in the subcontracting division. Kellett produced ailerons and flaps for the Republic Thunderbolt, stabilizers for the Curtiss Helldiver, engine mounts for the Consolidated Liberator, welded parts for the Grumman Wildcat, flaps for the Martin Baltimore, flaps and other assemblies for the Curtiss Warhawk and many other individual items.

Meanwhile, production of Kellett rotorplanes was continued, and a service test lot of YO-60 autogiros was delivered to the Army Air Forces. Other experimental types were being produced, with development proceeding in the helicopter field, which Kellett engineers had studied for more than six years. The company was operating five plant units in various sections of Philadelphia, and had doubled the number of employees.

Lockheed Aircraft Corporation, Burbank, Calif., absorbed the business and assets of the Vega Aircraft Corporation, also of Burbank, and the name Vega disappeared from the corporate identity of the greater Lockheed organization. Vega was a wholly-owned subsidiary of Lockheed for two years, and the integration was merely a compacting of two organizations into one—a continuation of the trend toward closer cooperation between two allied airframe builders.

The greater Lockheed company employed more than 90,000 men and women, working in more than 100 geographical locations in 18 nations on five continents. The Lockheed Employees Recreation Club became the largest industrial recreation club in the world. This club late in 1943 opened under its own management a new \$500,000 cafeteria and commissary serving 60,000 meals daily, 24 hours a day.

Subsidiary corporations wholly-owned by Lockheed were Lockheed Overseas Corporation and Lockheed Air Terminal. A majority of shares in Pacific Finance Corporation of California were acquired and owned by Lockheed during the year. Lockheed operated 18 manufacturing plants in Southern California; with service bases and modification centers in California, Texas, Northern Ireland and England. Lockheed service representatives lived and worked with combat units on every front.

Production was concentrated on the speedy all-purpose Army fighter, the Lightning P-38, and the Boeing B-17. The plants were

also in heavy production on the Ventura PV-1, a land-based patrol bomber and torpedo carrier for the Navy. First flown early in 1943, the mighty four-engine Lockheed Constellation C-69 transport was slow in getting into production due to the concentrated effort at Factory B to turn out P-38's, but early in 1944 the Constellation program was accelerated, too, as the Army Air Forces envisioned future needs for these huge passenger and cargo carriers in prosecuting the war against Japan. The Constellation proved ideal for carrying great numbers of troops or other Air Corps personnel, or many tons of cargo, into the distant interior of lands from which attacks on the main Japanese islands could be based.

Built originally by Lockheed for Transcontinental and Western Air, the 8800-horsepower Constellation was designed to fly across the United States in less than nine hours non-stop, or cross to Honolulu in about 12 hours. It would carry 62 passengers and a crew of five at a speed beyond that attained by a Japanese Zero fighter. Three of its powerful Wright Cyclone 18-cyl. engines would maintain a 26,000-foot altitude, sufficient to cross the Himalayas, and two would hold the plane at 16,500 feet.

The Lockheed Lightning P-38 had a splendid record as one of the finest all-around fighting planes in combat service anywhere. A new model Lightning was produced in 1943 with two Allison liquid-cooled engines aggregating 3,200 h.p. This made it the highest-powered fighter airplane in the world, and materially increased its own high altitude performance, particularly its climb.

The P-38 Lightning was definitely established as the world's most versatile airplane regardless of type. It was used in combat as a high altitude fighter, a low altitude fighter, an escort fighter, a fighter-bomber, an interceptor, a night fighter, a low altitude attack and ground strafing plane, a smoke screen layer, a tank buster and a photo-reconnaissance plane which, known as the F-5, had become a standard photo plane of the Army Air Forces.

Using two different types of releasable fuel tanks, it performed many long-distance feats that stamped it as having great range. Its combat record was outstanding, especially in the South Pacific, the Aleutians and the Africa-to-Italy operations, because its two engines gave pilots added safety and enabled many to get home when a single engine plane with power plant disabled would have been forced down at sea. American pilots called that second engine the "round trip ticket," while German pilots referred to the Lightning as "Der Gabelschwanz Teufel"—"That fork-tailed devil." This plane was used by many aces of the Army Air Forces who had record victories.

The Lockheed PV-1 Ventura was the Navy's first land-based twin-engine combat patrol plane with long range, plus offensive and defensive armament. It generally was equipped to carry depth charges or a standard torpedo in its enlarged bomb bay, and was heavily armed



by machine guns protecting all vital points, as well as nose armament for strafing or attack purposes. It carried more radio equipment than any other plane then built by Lockheed, and could land at less than 80 m.p.h. It was a highly successful anti-submarine plane and was described as "fiercer, farther and faster" than the Lockheed Hudson which it resembled. In fact, it replaced the Hudson which went out of production in 1943. Droppable gas tanks and fuselage tanks gave the PV-1 Ventura unusually long range for submarine and other enemy shipping patrol. Powered by two Pratt & Whitney 2,000 h.p. engines, the ship had a wing span of 65 ft. 6 in. and normally carried a crew of four.

Lockheed built B-17 Fortresses under the Boeing-Lockheed-Douglas pool, and accelerated production so rapidly during 1943 that in September the Factory A plant was turning out four times as many big bombers a day as had been built in January.

Soon after the last of the Hudson's came off the line, the company ceased building the C-60 Lodestar transport in order to accelerate production of P-38 Lightning fighters. The Lightning was given top priority for men, material and machines and everything else the company was doing had to fall in line behind the P-38 as the Army demanded a greatly increased production schedule. In the summer of 1943 production was doubled by the development of a mechanized final assembly line which moved down the hangar four inches a minute.

To meet the increasing demand for a fighter that would accompany bombers far enough out on missions over Germany to provide cover against the Nazi rocket and radio-controlled aerial torpedo techniques, as well as one that would do all the many useful things demanded of the Lightning, the company launched an accelerated production program under which hundreds of subcontractors and one prime contractor (Consolidated-Vultee) were to build this fighter. Consolidated Vultee was both a subcontractor, at its Downey plant, and a prime contractor, tooling up to fabricate and build complete P-38 airplanes at its Nashville, Tenn., plant. Other ranking national manufacturers building smaller components to be assembled at Lockheed included Hudson Motor Car Company of Detroit, the nationwide Rheem Manufacturing Company, Spartan Aircraft Company of Tulsa, Okla., Weber Showcase and Fixture Company, Avion Incorporated, and Timm Aircraft Corporation, all of Los Angeles. This acceleration was scheduled to treble the 1943 production rate of the Lightnings.

Lockheed's production of Lightnings, B-17's and PV-1's also was speeded up by branch subassembly plants at Fresno, Bakersfield, Taft, Santa Barbara and Pomona. These plants, hiring in total many thousands of workers living in the various cities, turned out everything from wing leading edges and bomb bay doors to torpedo racks, bomb racks and horizontal fins. The introduction of manpower at the main factories in Burbank as well as in some of these branch plants

tapped a new labor market. The boys, 16 and 17 years of age, were working and going to high school either four hours a day alternately, or were working four weeks and attending school the next four weeks. The program was endorsed and set up by the boards of education and the high schools of the various communities, with the full backing and cooperation of the State education authorities. Under the Lockheed plan, no high school boys under 18 were hired directly by the company, but were cleared in through their school authorities who assigned a faculty representative to go out into the factories with them each day and be available at all times for advice and counsel. The boys had to keep up with their studies or drop out of the program. They were to graduate with the rest of their class.

Outstanding among the company's many enterprises, all designed to further the cause of aviation, and particularly to bring the prosecution of the war to a quick and successful conclusion through the use

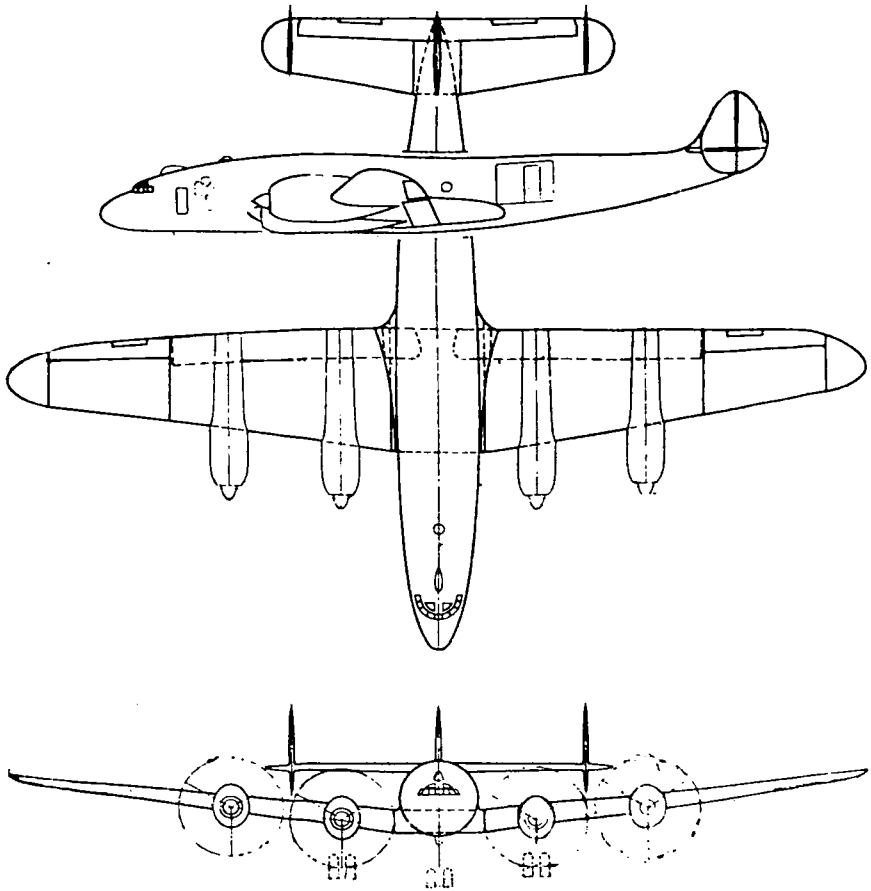

THE LOCKHEED CONSTELLATION

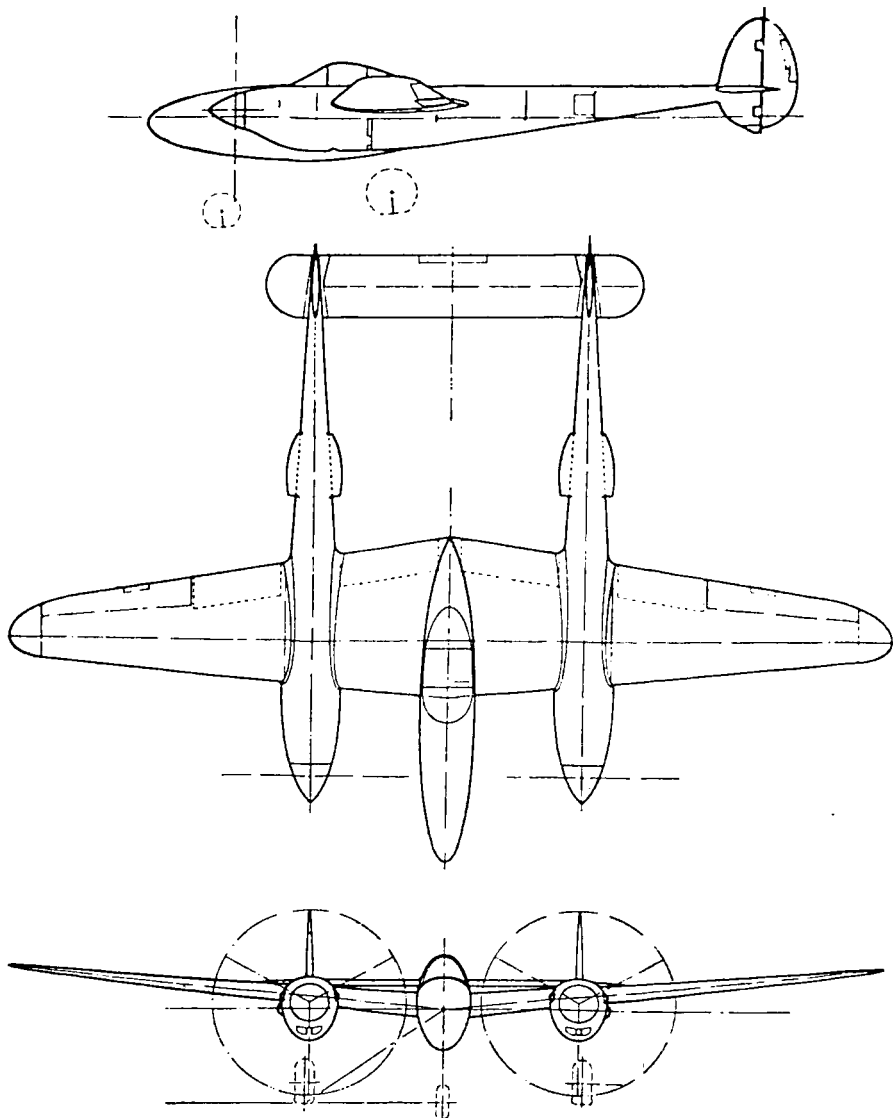

THE LOCKHEED LIGHTNING P-38 FIGHTER

of air power, was the Lockheed service empire in which more than 10,000 men and women were busy in many parts of the world keeping American-made airplanes of many types in the air. Largest was the Lockheed Overseas Corporation service, assembly and modification base in Northern Ireland. Others were located in England, with smaller units in Iceland, Africa, India, the South Pacific and the Aleutians. A modification base for Army planes located at Dallas, Texas, and a new one for the Navy built in San Fernando Valley, near the main factories, early in 1944, were among the largest and most im-

portant in the world. A customer service division was in full operation at Lockheed Air Terminal, Burbank.

Lockheed's 1944 program included (1) further increased production of the P-38, (2) continued on-schedule production of the B-17, (3) building up a production line of Constellations, (4) superceding the PV-1 Ventura with a new Navy model, and development work on secret new models.

McDonnell Aircraft Corporation, St. Louis, Mo., increased its shipments of airframes by more than 100 per cent by delivering 1,737,000 lbs. in 1943, as against 847,000 lbs. in 1942. Floor area increased more than 216,000 sq. ft., making a total of 743,000 sq. ft. The personnel expanded from less than 2,000 on December 31, 1942, to more than 5,000 at the beginning of 1944. With such an increase it was necessary that the training program be expanded and 1,435 individuals received instruction in the pre-employment and in-plant courses, as compared to only 83 persons the previous year. A total of 962 persons took advantage of supplementary training in 23 courses.

The McDonnell safety record for the year was more than twice as good as the average for the industry, for in the accident frequency rate terms of the National Safety Council, which compare the number of lost time accidents to the number of hours worked, McDonnell's rate was 5 as against that of 11.4 for the industry. The year 1943 saw substantial steps made on important primary contracts with the United States Government, details of which were not disclosed. The first McDonnell built AT-21 gunnery trainer was nearly completed at the beginning of 1944.

The McDonnell Plastic Division was started in 1943, and a plastic trademarked STRUCTOMOLD was developed. By the end of the year 97,000 lbs. had been shipped in the form of gun turret parts and ammunition boxes. The company made substantial deliveries of empennages for the C-47 cargo transport and cowls for the A-20 attack bomber. Orders early in 1944 totaled more than \$50,000,000.

The Glenn L. Martin Company, Baltimore, Md., was in production on three types of military aircraft, the B-26 Marauder medium bomber; the PBM-3 Mariner twin-engine Navy patrol bomber, which also was a cargo carrier; the 187 Baltimore (Army A-30) light bomber supplied to the British under lease-lend. Martin also started the year 1944 with an additional Navy order for 20 giant Martin Mars flying boats. At the same time the company maintained its position as a leading supplier of power-operated turrets.

The Martin Mars, giant 70-ton flying boat, in final tests imposed upon it by the company and then by the Navy, culminated in a 4,375-mile non-stop hop over the Atlantic from the Patuxent River in Maryland to Natal, Brazil. Some of the world records set by the Mars in the course of the round trip and announced by the Navy included: Longest over-water flight, Patuxent to Natal, greatest air

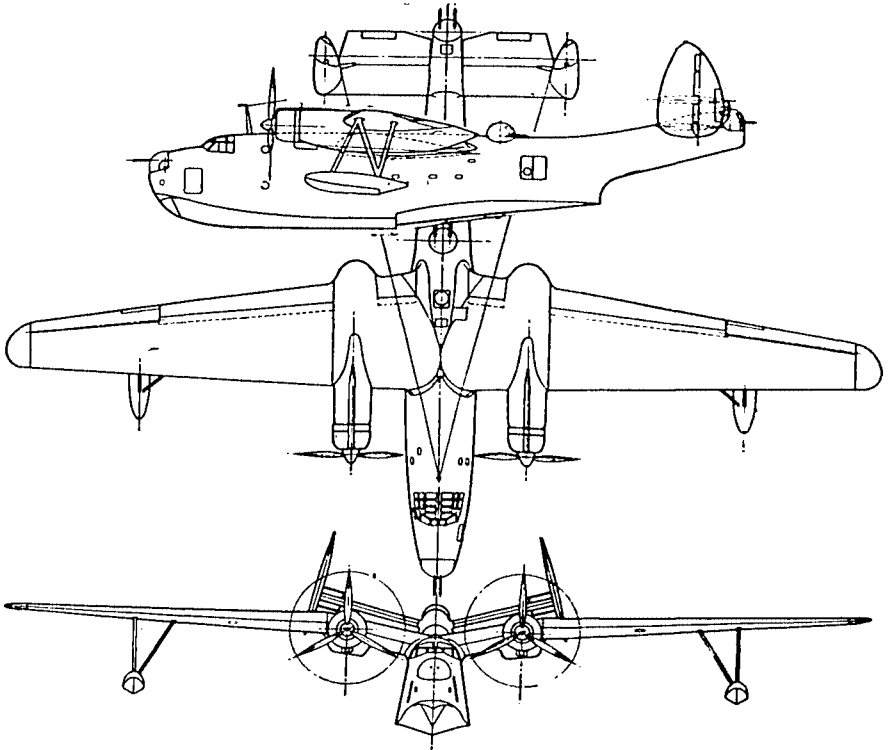

THE MARTIN PBM-3 MARINER

cargo—35,000 lbs., heaviest load ever lifted by a plane, 148,500 lbs. gross at take-off from the Patuxent, and longest non-stop cargo flight. In all, the Mars covered on her shakedown cruise 8,972 miles in 55 hrs. and 31 min. of flying time. A total of 48,000 lbs. of priority war materials, as much as 10 standard planes could carry, and well over the capacity of a regular freight car, was transported at an average speed of 161 m.p.h. During part of the return trip, a 35,000 lb. load was flown many miles over the matted, dangerous Amazonian jungles. After this exploit, Secretary of the Navy Knox announced that Martin would build 20 more of the giant cargo flying boats. The Mars had a wing spread of 200 ft. and a cubic content equivalent to that of a 15-room house. It was powered by four Wright Cyclone-18 engines of more than 2,000 h.p. each. It could carry in excess of 15 tons of cargo. Martin engineers visualized in the Mars the pattern for fleets of such over-ocean transports, both during the war and afterwards, and were planning for larger flying boats for peacetime use.

The year was a banner one for performance of Martin planes in various parts of the globe. The Martin B-26 Marauder proved to be one of the deadliest bombers used by the Army Air Forces. A medium type bomber of mid-wing monoplane design, its construction



was all-metal monocoque. It had a retractable tricycle landing gear, two Pratt & Whitney 2,000 h.p. engines, four-blade Curtiss automatic electric propellers, and all the latest features dictated by combat experience in various war zones. The B-26 Marauder played a large part in rolling back the Japanese in the Pacific, in the conquest of North Africa, Sicily and Southern Italy. During the last five months of 1943, Marauders made 6,700 sorties from England against installations in Northern France, Holland and Belgium. Their combat safety record, according to our 8th Air Force Headquarters in England, was three-tenths of one per cent loss. The plane was built both at the Baltimore and Nebraska plants operated by the Martin company.

The Martin PBM-3 Mariner Navy patrol bomber, weighing from 25 to 28 tons, built up a fine record of submarine sinkings, ocean patrol, rescue work, and advance scout and convoy duty. Martin PBM-3 Mariner Navy transports, weighing 55,000 lbs., were used for long-range flying of critical supplies. During the year the Navy asked for increased output of Mariners, and the U. S. Coast Guard sent officers from various bases for indoctrination in maintenance of the huge gull-winged ships, in preparation for the Coast Guard's acquisition of a number of them.

The Martin A-30 Baltimore, a light bomber used by our British Allies, played an important part in driving the Germans from North

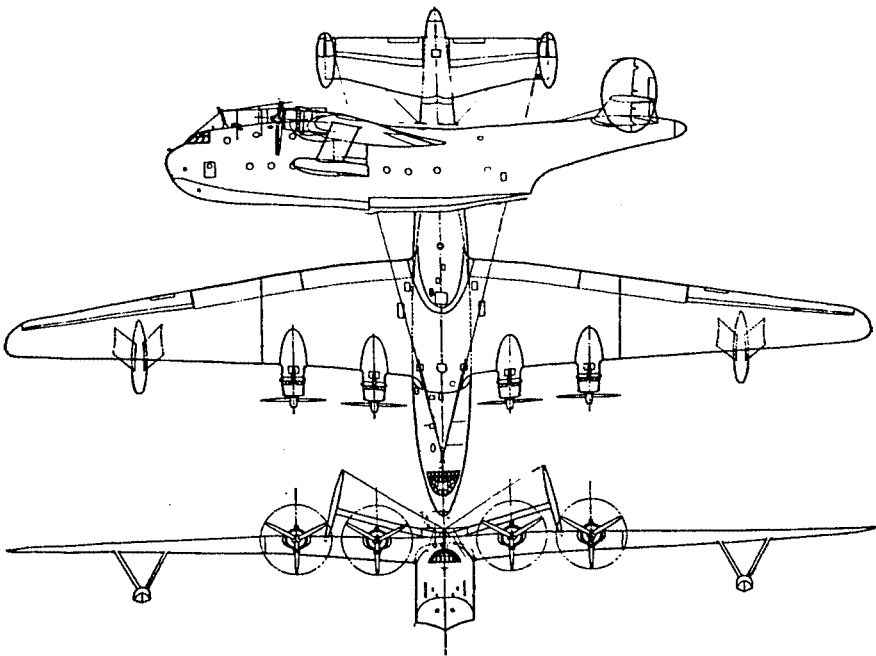

THE MARTIN NAVY MARS

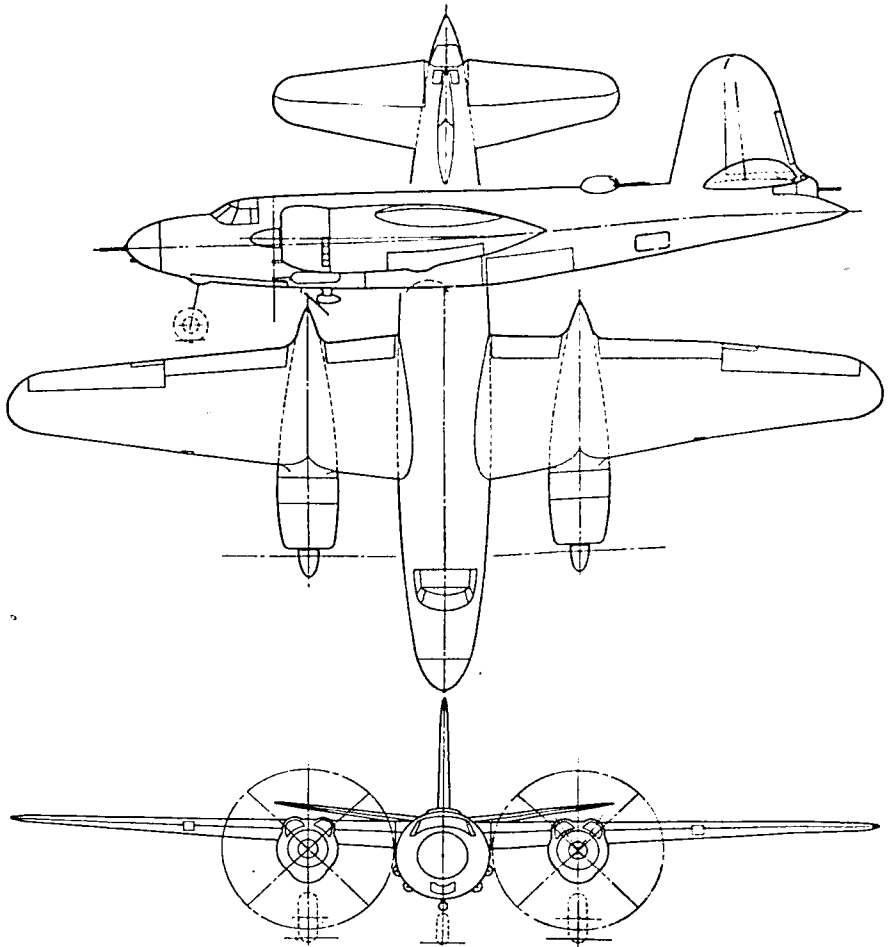

THE MARTIN B-26 MARAUDER

Africa, Sicily, and Southern Italy. Previously it had contributed a great deal to the successful resistance of Malta. Somewhat lighter than the B-26 Marauder, the Baltimore was powered by two 1,600 h.p. Wright Cyclone engines and carried a crew of four.

A number of factors contributed to the Martin company's increased production of planes. Through operation planning, position installations on conveyors were utilized to a high degree. Special equipment was introduced to reduce operation times to a minimum. The manufacturing department influenced the design of new models of sub-assembly breakdowns into panel designs, which permitted faster installation.

The Martin training program placed thousands of men and women in both in-plant training classes and courses set up in public schools

and colleges, fitting them for the myriad specialized jobs of aircraft design, manufacture, and inspection. Women formed over 33 per cent of the personnel, and were employed in almost every kind of job in the plants.

Martin entered 1944, its 35th year of continuous production, with full production schedules of bombers, transports and turrets. Martin planned to continue the development of military aircraft after the war, and also to play an important part in the development and building of planes for peace-time transoceanic, intercontinental and domestic travel and transport. In the Mars and PBM-3 Mariner, Martin engineers had two ideal types already developed; with plans for over-ocean flying boats twice as large as the 70-ton Mars. In the Van Zelm cargo airplane the Company had a radical new type of cargo plane which carried its own loading ramp and equipment, thus making aerial freight service economically practical in areas where the volume of business would not be sufficiently large to warrant elaborate loading equipment.

Along with the postwar production of both military and civilian aircraft Martin had other products already developed by its engineers. Among them were Marvinol, a new chem-elastic designed to replace rubber as the standard material for many articles; Mareng cells, which permitted the use of boxcars and other dry-freight vehicles for transportation of oil and gasoline; an improved diluent system for cold-weather starting of internal combustion engines, used on aircraft and adaptable to the engines of buses, trucks and pleasure cars; and vibration-detecting equipment, widely used in the testing of aircraft, and useful to designers of vehicles, bridges, and buildings housing heavy machinery.

The Meyers Aircraft Company, Tecumseh, Mich., specialized in design and manufacture of light training and touring aircraft, wheels and shock absorber struts. Meyers models were the OTW, OTW-



#### IN C.A.A. WAR TRAINING SERVICE

Line of Meyers OTW trainers powered by Kinner R-56 160 h.p. engines.

145, OTW-160 and ME 165W. Meyers planes were standard equipment in aviation schools. The Meyers was designed to fill the need for a training plane that would combine in one unit all the essential requirements for both primary and advanced training. The all-metal fuselage reduced maintenance and upkeep to a minimum.

North American Aviation, Inglewood, Calif., with four giant plants in California, Texas and Kansas, manufactured three leading military aircraft of its own design during 1943, and began quantity production on the Liberator bomber. The North American P-51 Mustang fighter, B-25 Mitchell two-engine bomber and the Consolidated B-24 Liberator four-engine bomber were used for combat operations in the major war theaters. The Mitchell held the added distinction of having seen action over every battlefield in the world. The North American AT-6 Texan was in use as a combat trainer, and occasionally was employed for tactical purposes by 27 of the Allied nations.

North American's home plant in California produced Mitchell bombers and Mustang fighters. The plant in Kansas was devoted entirely to the manufacture of Mitchells, while two plants in Texas manufactured the Texan combat trainers, Mustang fighters and Liberator heavy bombers. In addition a modification center in Kansas was operated to prepare Mitchells for specific operations or for designated theaters of war.

Facilities at the Texas plant, which previously had built Texan trainers exclusively, were expanded to manufacture Liberators and Mustangs in addition to carrying on the company's trainer program. Only 317 days after the contract was signed bringing North American into the Liberator "pool" manufacturing the heavies, its first four-engine bomber made its initial flight. The Texas plant was organized, as were all the divisions, to obtain maximum flexibility in production and thus insure that all planes would incorporate at the earliest possible date the latest design changes to meet demands of fast changing tactical requirements.

During February, 1943, the Texas division set a record when the 10,000th AT-6 Texan trainer was delivered. In 1943 the same plant also produced over 50 per cent of the total AT-6's produced prior to that year. It was the largest number of planes of one basic design ever manufactured. The production of trainers was in addition to North American's increased output of the Mitchell in California and Kansas, the Mustang in California and the beginning of production on the Liberator and the Mustang at the Texas division.

The North American B-25 Mitchell medium bomber maintained its place as a leading twin-engine bombardment plane. The newer version of the Mitchell carried a 75-mm. cannon, the largest weapon ever installed on an airplane. Used extensively in the South Pacific and elsewhere it was credited with sinking Japanese ships and destroying important enemy military targets. The projectiles were

capable of penetrating both sides of a medium tank, and they could put an anti-aircraft battery out of action.

In making the changes on the Mitchell to accommodate the cannon, a shorter nose structure was designed to replace the Lucite-enclosed bombardier's compartment, and some revision was made in the pilot and the navigator sections. The cannon was installed in what formerly was the crawlway connecting the nose of the plane with the pilot section, and the muzzle projected through a blast tube in

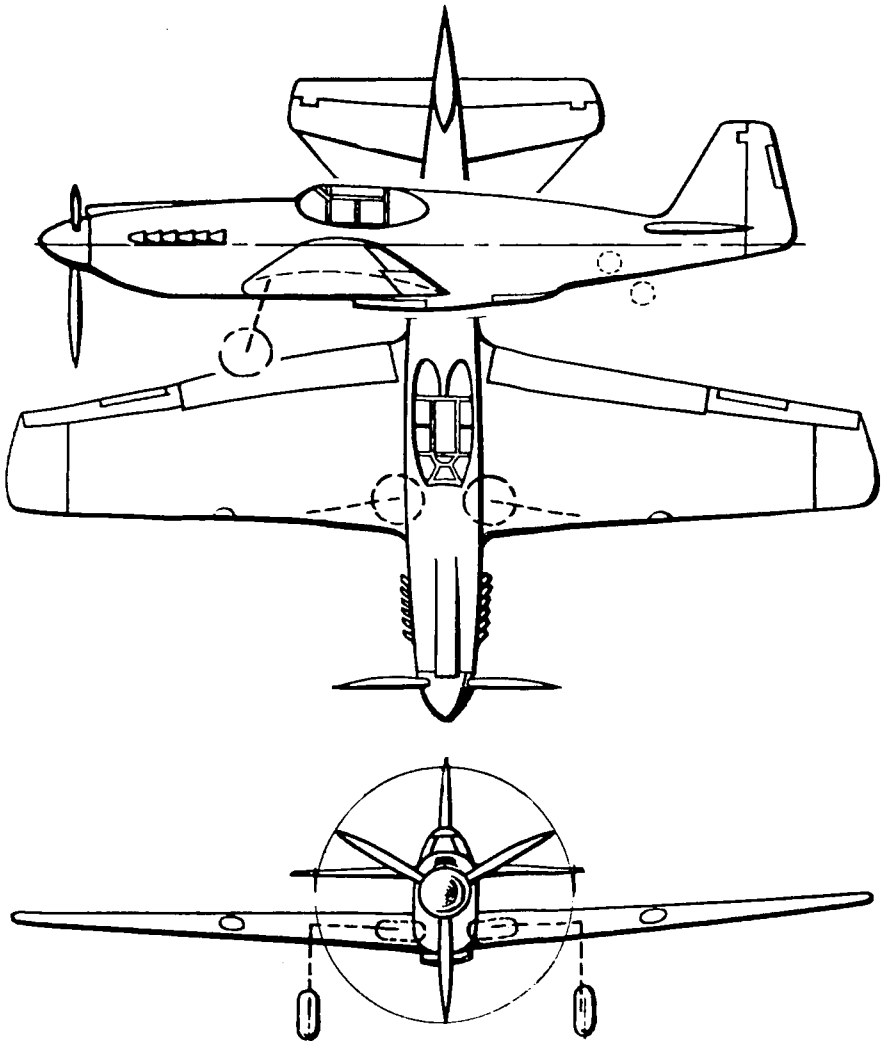

NORTH AMERICAN MUSTANG

This single-seat fighter had an Allison engine. Other models had the Packard Rolls-Royce Merlin.



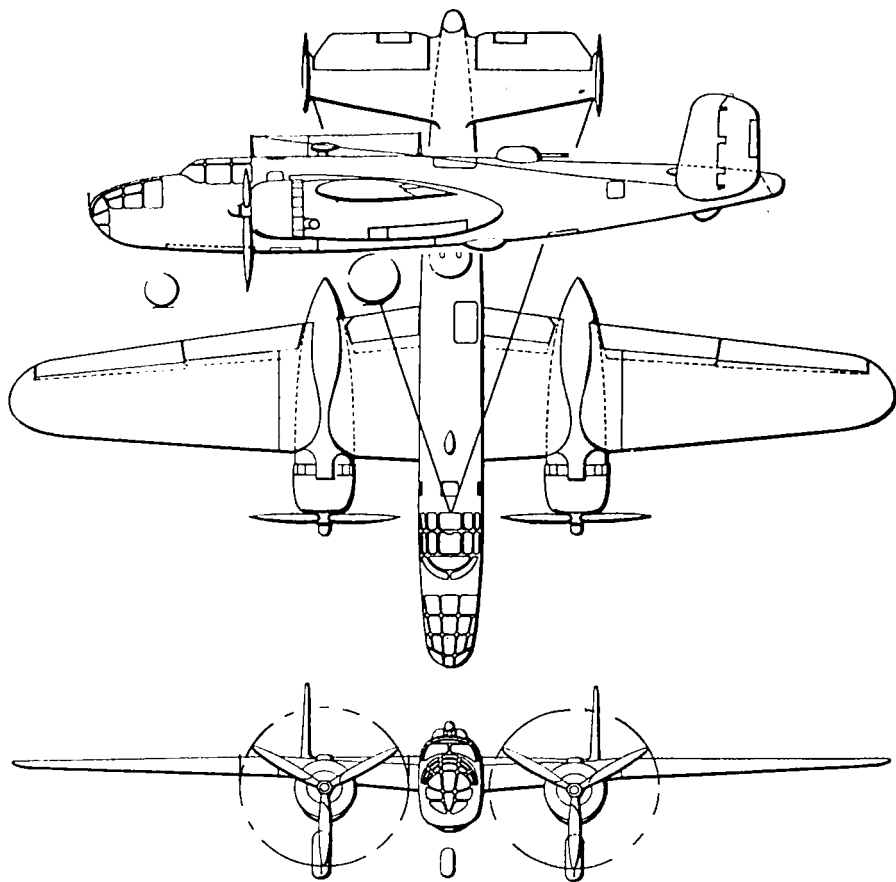

NORTH AMERICAN B-25 BOMBER

Known as the Mitchell, this medium bomber was powered by two Wright Cyclone twin-row engines.

the lower nose section. One of the most versatile planes yet developed, the Mitchell was equipped through progressive design changes for an amazing assortment of combat functions. It was fitted for operation under all tactical and weather conditions, and was used for medium altitude bombardment, low level bombardment, troop strafing, torpedo carrying, armed anti-submarine patrol, and photo reconnaissance, and even served as a fighter. Despite the addition of the cannon, the Mitchells still retained their effectiveness in all functions. Robert A. Lovett, Assistant Secretary of War, wrote in the Army and Navy Journal: "There are few more dramatic examples of the advantage of constant improvement of current models than the modifications and design changes in the B-25 medium bomber. It is serving in every theater of the war completely around the world. A superb medium bomber, the Fifth Air Force in the Southwest Pacific, work-

ing with North American Aviation, has converted it into a devastating attack bomber with tremendous firepower forward and a specialized technique in medium altitude bombing of shipping."

The War Department announced that during June, July and August, 1943, the Mitchells flew a record number of 10,700 sorties, cascading about 12,000 tons of bombs on the enemy. They raided such widely separated targets as Pantelleria, Salerno, Lae and Hongay and attacked the Japanese forces in the Kiangsi province of China, and the Germans in Russia. In July, B-25 Mitchells participated in the first raid on Rome, and dropped more than 80 tons of bombs on Comiso in southeast Sicily. In larger force B-25's based in Northwest Africa staged one of the longest combat missions ever undertaken by medium bombers in that part of the world, attacking the Ciampino airdrome near Rome, some 1,000 miles from their base.

The latest North American P-51 Mustang fighter, powered by a Packard-built Merlin engine, saw action for the first time early in December, 1943, and on successive raids accompanying heavy bombers the Mustang penetrated deeper and deeper inside Germany, finally reaching Berlin's inner defenses. The fighter-bomber version of the P-51 Mustang, which was designated by the Army Air Forces as the A-36 and nicknamed Invader by its pilots, incorporated dive brakes, bomb racks and six high calibre machine guns into the clean lines of the deadly little fighter, making it one of the fastest fighter-bombers in the world. Powered by a 12-cyl. Allison engine, the Invader was capable of diving on a target at a terrific rate of speed, blasting the enemy with bombs and then fighting it out with any plane in the skies.

The A-36 Invader made its first appearance immediately prior to and during the invasion of Sicily. Flown in combat by American pilots, the plane successfully destroyed shore installations, trains, trucks, roads and airfields during softening-up operations that made invasion immeasurably easier. One observer described its operations in these words: "The scream of the plane when it comes down would shake any man—makes the Stuka sound like an alley-cat."

Some of the fighter versions of the Mustang were equipped with four 20 mm. cannon for use by the Royal Air Force, principally against Axis locomotives and shipping. Until a few months before the Italian invasion, Mustangs were used exclusively by the British and were preeminently successful in numerous types of operations over Europe. To illustrate these operations, two pilots of the Royal Canadian Air Force squadron flying Mustangs had what they called a "successful field day" over northern France. In less than 40 minutes they attacked a dozen railway engines in a comparatively small stretch of 90 miles. As one pilot described it, "we most certainly hit everything we fired at and of the 12 engines hit, seven looked as though they were pretty badly damaged."

The new high-altitude P-51B Mustang was equipped with the

Packard-built Rolls Royce Merlin engine. This fighter supplanted the original Allison-powered Mustang in production, and late in 1943, began to play an important part in the air war five or six miles above the ground and more than 450 miles from its home base. The Merlin engine in the Mustang utilized a two-speed, two-stage supercharger and drove a constant speed four blade propeller. The ability to fight at high altitudes was a startling departure for the Mustang, which previously had gained its acclaim as a fighter and fighter-bomber at medium and low altitudes. The Office of War Information stated the P-51B Mustang's speed to be well over 400 miles an hour and its ceiling up to 40,000 feet.

In 1943 North American had to cope with many of the same problems encountered during the previous year, with most of which the expanding aircraft industry was well acquainted, lack of experienced personnel and material and equipment shortages. The acute employment problem was intensified by increased production requirements. Employees leaving for the armed services and the depleted reservoir of skilled labor left a gap that was filled by women and by unskilled and physically handicapped persons. North American conducted a comprehensive inplant training program for new employees, and through the cooperation of public schools, supplemental training opportunities were made available to both men and women. A program to employ and train war veterans was started. Boys of 16 and 17, who continued to attend school regularly, were employed on a part time basis. The nucleus of a highly-skilled staff retained by the company provided the necessary supervisory leadership to maintain quality and production standards. During 1943 a decentralization program was put into effect, moving the work closer to dwindling manpower supplies. The number of employees in the North American plants almost doubled in 1943, even though terminations numbered more than the original employment total.

An excellent education program for all employees and careful study of working conditions by trained safety engineers enabled North American to establish a fine safety record. A 15 per cent improvement over the 1942 safety record was achieved, despite the increase in man-hours and hiring of inexperienced as well as handicapped employees.

North American's 1943 productivity was considerably higher than it had been during 1942, due to improvements made in tooling, layout, machinery, handling and processing equipment and assembly techniques. Many of these improvements were the work of the methods and tool design departments, and many resulted from the seven-year-old employee suggestion plan, which in 1943 showed a 164 per cent increase over 1942 in suggestions submitted, a 242 per cent increase in awards and a 250 per cent increase in suggestions adopted. The ideas were made available to other companies.

North American's California division spent 432,260 engineering

hours on the Mitchell and 554,722 hours on the Mustang, incorporating design changes that kept the two planes superior to the best the enemy could put into the air. In addition to design work, considerable effort was directed to experiments in high speed aerodynamics, pioneer research that would be reflected in later design changes. North American's investigations into laminar flow theory, internally balanced ailerons and other installations were used in the development of new aircraft designs.

Material salvage and substitutions resulted in an estimated saving of \$2,311,576. This conservation program's greatest significance was the maximum utilization of strategic materials. Engineers were employed to study methods and recommend conservation improvements. Strategic materials which were not needed immediately for North American production items were made available to other companies.

With the greater use of Mitchells, Mustangs and the Liberators on all the battlefronts of the world came expansion of the engineering field service department. Field service representatives were stationed at bases throughout the world from which Mitchells and Mustangs were in operation against the enemy. Of the 112 well-trained specialists, 62 were in foreign countries observing and aiding our Army Air Forces in its operation of the combat planes. Representatives were stationed in such remote places as Fiji, New Caledonia, Algiers and Guadalcanal. They relayed to North American engineers information concerning the operation of the Mitchell and the Mustang under combat conditions, and this data served as a guide to design changes which were of vital importance in future campaigns.



THE NORTHROP PATROL BOMBER IN ICELAND

The first unit of the Norwegian Naval Air Force, which was organized in Canada, used these machines on patrol duty in Iceland.

Northrop Aircraft, Inc., Hawthorne, Calif., was in production on its new P-61 Black Widow night fighter for the Army Air Forces. The first Northrop designed military airplane since the N3-PB, which was manufactured for the Royal Norwegian Naval Air Force, the Black Widow was a heavily armed and armored plane designed specifically for night fighting. It was the first functional night fighter, as preceding aircraft used for this purpose were modifications of other tactical types. With two Pratt & Whitney 2,000 h.p. Wasp engines, the Black Widow developed pursuit speed while retaining low landing speed and easy flying characteristics necessary for night operations.

Northwestern Aeronautical Corporation, Minneapolis and Saint Paul, Minn., completed its first contract with the Army Air Forces ahead of schedule on July 23, 1943. This was for the manufacture of 15-place troop carrier and cargo gliders, known as the CG-4A. The craft was designed by the Waco Aircraft Company with a view to maximum strength and minimum weight. The fuselage construction was welded steel tubing. The wings and floors were of wood construction. Both fuselage and wings were covered with fabric.

For the first part of the year the company was operating in a plant at the Minneapolis Airport. Two sub-contractors in the Twin Cities provided the steel frames and wooden parts. Two new contracts were awarded the company by the Air Forces at the completion of the first. The expanded operations resulting from these contracts made it necessary to increase facilities for the production of wood and metal parts, as well as for assembling. Additional property was acquired in the Twin City area, and by September the company had approximately 300,000 sq. ft. of floor space available for its operation.

One of the two new contracts was a second order for CG-4A gliders. The other contract called for the manufacture of a new and larger tactical transport of the glider type known as the YCG-13. This ship also was designed by Waco on the same general principles as the CG-4A. The YCG-13, however, had twice the load capacity of the former, although its 86 foot wingspread was only a few feet greater. The nose section of the new model was of improved streamlined design with additional view for the pilot and co-pilot. The nose section of both models could be raised to permit loading and unloading. The mechanism for this operation in the new model was hydraulic. The YCG-13 also had hydraulically operated wing flaps and a tricycle landing gear. One entirely new feature was the aerial delivery rack which could be used for dropping equipment, or possibly for bombs.

After spending several months designing and making the hundreds of necessary tools and jigs, production of the YCG-13 was started late in September, 1943. On December 1, at the Minneapolis Airport, the first ship came off the production line and was given a completely successful test flight. It was the first production line ship of this new design to be tested.



Piper Aircraft Corporation, Lock Haven, Pa., concentrated most of its production on the Piper Cub L-4 Army Grasshopper, a military version of the J3 Cub trainer. These planes were in service on all fronts, with the artillery, tank corps, cavalry, infantry and air forces, directing artillery fire and troop movements, checking camouflage, transporting officer personnel, delivering vital messages and spotting enemy infiltration. Ability to fly at low speeds, land and take off on small restricted areas and maneuverability made these small planes exceptionally useful. The L-4 was a 2-place, closed monoplane with a wingspread of 22 ft. 3 in., height 6 ft. 8 in., weight empty 750 lbs., payload 420 lbs., stated top speed 90 m.p.h., cruising at 85 m.p.h., landing at 35 m.p.h., service ceiling, 12,000 ft., range 260 mi. It had a 65 h.p. Continental engine.

The Piper AE-1 Navy Ambulance plane, a conversion of the 100 h.p. J5C Super Cruiser, were put into service at all Naval aircraft stations. When adequate medical care could not be given to injured personnel on the spot, the AE-1 was flown to the location, the casualty placed aboard and flown comfortably enclosed under the plane's hinged turtle-deck to a base hospital. The ability to get into and out of unusually small fields and isolated areas made it ideally suited for this important work.

The new Piper PT-1 trainer was produced in May, 1943. Powered with a Franklin 6 AC-298, 50 h.p. engine, this two-place trainer, with a retractable landing gear, had a stated top speed of over 150 m.p.h. Its landing, take-off and stall characteristics, and its speed which was sufficient for advance maneuvers, made it well suited for early and transitional training periods. With a cruising range of over 600 miles, it was good for cross country training. It also had an auxiliary panel and hood to convert it into an ideal instrument trainer.

In order to maintain delivery schedules, Piper had to replace approximately 50 per cent of the employees who were called into service. Total personnel was increased 25 per cent, and percentage of woman employees was increased 150 per cent. An intensified training campaign was inaugurated and a school set up to instruct aircraft welding, sheet metal and general shop practice. A number of courses also were given to prepare and train supervisor personnel. The plant increased production floor space approximately 25 per cent over that of 1942.

Republic Aviation Corporation, Farmingdale, Long Island, N. Y., with another division at Evansville, Ind., designed and produced the Army P-47 Thunderbolt fighter, a six-ton plane with a speed of over 400 m.p.h. and a fine record for superiority in performance on all fronts where the Army Air Forces were fighting Japs or Germans.

The Thunderbolt was a single-engine low-wing, single place, all metal monoplane with a single tail, with bulky oval shaped fuselage and an elliptical wing among its individual features. It was used in fighter sweeps at high and medium altitudes, as a fighter protection

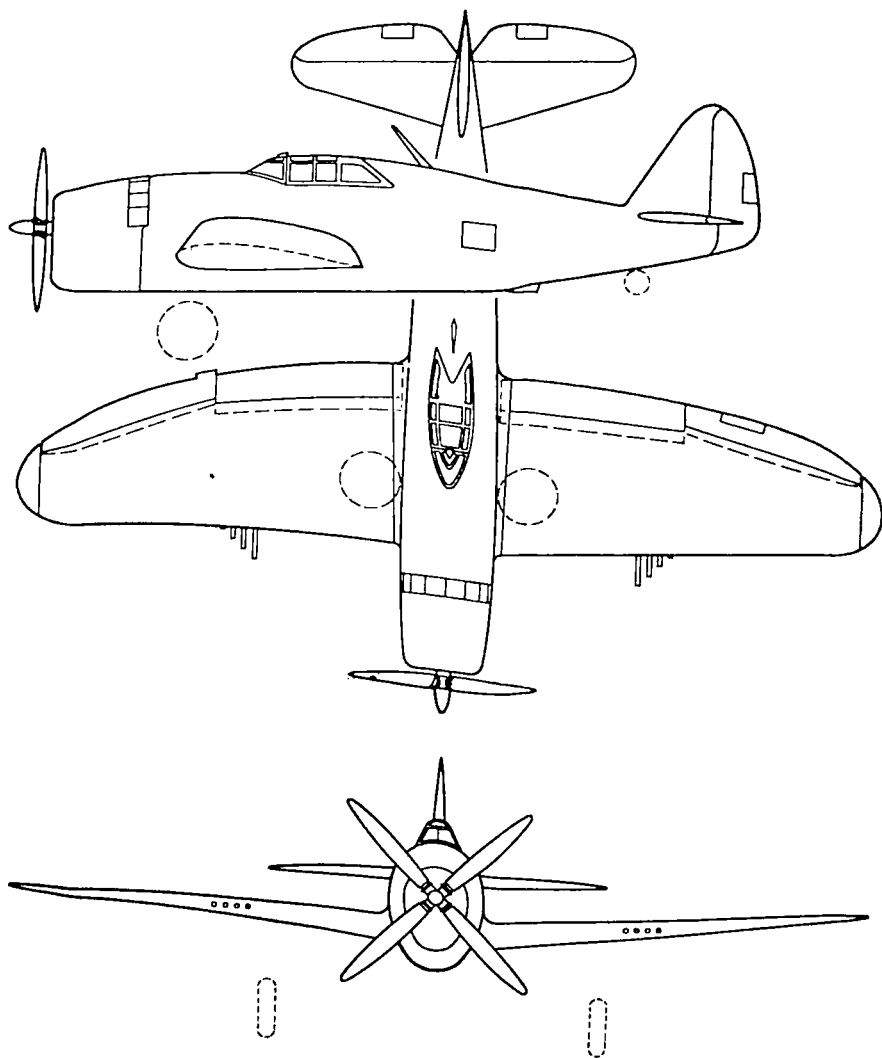

### REPUBLIC THUNDERBOLT

A high altitude fighter powered with a Pratt & Whitney Double Row Wasp engine rated at 2,000 h.p.

for bombers and as a fighter bomber. It had a wing span of 40 ft. 8 in., length 36 ft. 1 in., height 14 ft. 2 in., tread width 15 ft. 6 in., wing area 300 sq. ft., and weighed over 13,500 lbs. maximum. It was powered by a Pratt & Whitney 2,000 h.p. 18-cyl. twin row Wasp engine equipped with both geared and turbine superchargers and a Curtiss electrically controlled, constant speed, multi-position propeller. Its service ceiling was about 40,000 feet, and tactical radius of action 350 miles as an escort fighter. Its announced bomb load was 500

pounds. It carried eight .50-cal. machine guns in the wings, and was protected with front and rear armor for the pilot, leak proof fuel tanks and bullet-proof glass. The Thunderbolt was one of three fighter planes which escorted our Army Air Forces bombers on their daylight precision bombing attacks on Berlin in March, 1944, the other two being the Lockheed Lightning and the North American Mustang. To give the Thunderbolt extra long range for escort operations, a belly tank was added, and later two wing tanks.

Republic's big inland division plant at Evansville, Ind., was completed in 1943, and it delivered a thousand Thunderbolts within 20 months after ground was broken. The Farmingdale plant had three new manufacturing and warehouse buildings, two huge hangars, a maintenance building, auxiliary power house, new runways and other facilities.

Robertson Aircraft Corporation, Robertson, Mo., held prime contracts and was in production on its second order of C.G.-4A gliders for the Army Air Forces. During the early half of 1943 Robertson also operated a mechanics school for the Army Air Forces Technical Training Command, and a war training service under the C.A.A. for Naval Aviation in cooperation with Westminster College at Fulton, Mo.

Ryan Aeronautical Company, San Diego, Calif., undertook development of an advanced type of combat plane for the U. S. Navy, which had it on the secret list. Although great emphasis was put on the new project, Ryan at the same time produced bomber assemblies and a tremendous volume of exhaust manifold systems. These specialized Ryan manifolds were for some of the world's most famous planes, including the Douglas twin- and four-engine military transports and



THE THUNDERBOLT WITH EXTRA TANK

Republic P-47 Thunderbolt with belly gasoline tank to extend its fighting range.



RYAN PT-25 MILITARY TRAINER

A plastic-bonded plywood primary trainer, full cantilever monoplane of advanced design, developed by the Ryan Aeronautical Company, San Diego, Calif. It was powered by a 185 h.p. Lycoming 6-cyl. horizontal opposed aircooled engine.

Havoc attack bombers, Consolidated Catalinas, Grumman Hellcat fighters and others, among them new types which were held secret.

Ryan also built its manifolds (incorporating the patented ball and socket joint) for the new 2,000 h.p. series of engines, the most powerful aircraft engines ever designed. Research and engineering were pushed steadily forward on new applications in connection with the manifold system's prime job of discharging exhaust gases and heat.

Ryan manifolds were developed to power turbo-superchargers, dampen exhaust flame and transfer heat for carburetion, cabin heat, wing anti-icing, gun installation heating and warming of surface controls, thus putting to good use a source of energy which was formerly wasted. Ryan engineers and research experts were constantly exploring new applications of wasted exhaust heat and developing new and more efficient types of heat exchangers. Another development was the short or ejector type of exhaust system which opened up an entirely new field of design.

Ryan's military primary training planes were in use throughout the world by our Army and Navy and the air forces of Australia, India, China and Latin America. Many of America's new crop of aerial heroes won their wings in Ryan trainers at Ryan-operated Army flying schools. Ryan S-C planes were on coastal anti-submarine patrol for the Civil Air Patrol. Another major expansion of the company's manufacturing facilities, its fourth since 1938, took place during 1943. An immense new final assembly building and a new office and engineering building were constructed. The final assembly building was adapted to the manufacture of much larger aircraft and assemblies than Ryan had built in the past, and it was being used for carrying

out larger production contracts held by the firm. It had 200-ft. wooden span trusses with clearance of 35 ft. in order that huge cranes could lift completed assemblies vertically from one production fixture to another. The Ryan plant site covered 38 acres.

Ryan tripled production in 1943 with a relatively small increase in manpower, according to executives. New production methods—including many short-cuts suggested by the employees themselves—were partly responsible. One employee originated a device that cut aileron discs 54 times faster than previous methods. Another designed a loading fork for the heat-treat furnaces which saved 120,000 lbs. of steel in 1943, and cut loading time in half. The management installed important new production methods. A flow control system reduced the time required for manifold production in some cases by as much as nine days. Hundreds of man-hours were saved by new assembly jigs. A radically new system of quality control saved \$1,300 weekly on scrapped materials. Personnel policies which stepped up recruiting, cut labor turnover, improved morale and gave employees strong



THE SIKORSKY HELICOPTER

It is shown here giving a demonstration of a vertical landing on the deck of a ship.

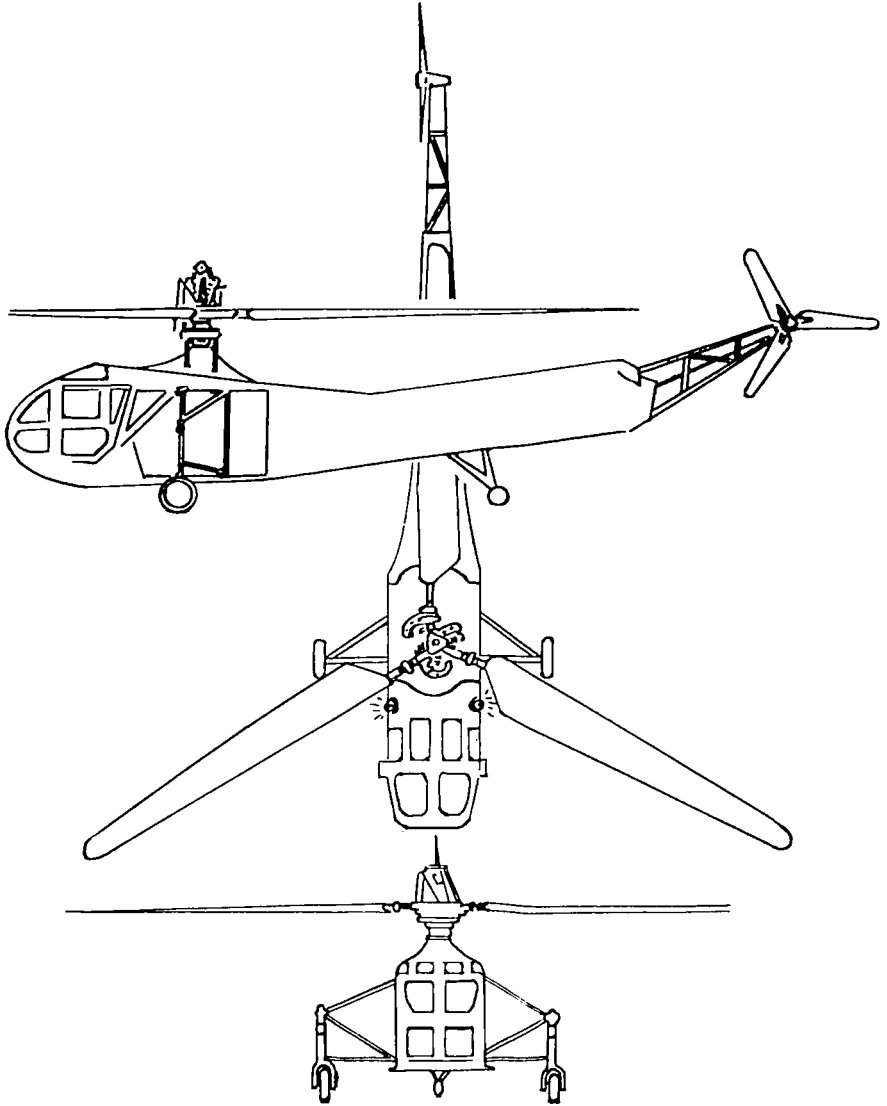

THE ARMY SIKORSKY YR<sub>4</sub> HELICOPTER

confidence in the company management contributed to Ryan's excellent production record.

St. Louis Aircraft Corporation, St. Louis, Mo., produced PT-23 primary training planes for the Army Air Forces. This two-place, open cockpit trainer was powered by a Continental 220 h.p. engine, had a span of 36 ft., length 25 ft. 11 in., and height 7 ft., 6 in.

Sikorsky Aircraft Division of United Aircraft Corporation, Bridgeport, Conn., in 1943 built the first production models of helicopters to be constructed in the United States. These were two-place

models for the Army Air Forces, designed by Igor Sikorsky and based on the original VS-300 helicopter—the first successful aircraft of that type in this country. Sikorsky Aircraft moved from Stratford to Bridgeport, where a leased factory was occupied, tooled up and put in production.

One feature of the new plant was “the smallest airport in the world,” an area just outside the factory building. It resembled an automobile parking lot in size. The Sikorsky division made full use of subcontracting, a method followed by all United Aircraft divisions, in meeting the wartime need for rapidly increased production. The original Sikorsky helicopter—the experimental VS-300—was placed in the Edison Museum in Dearborn, Mich. Nash-Kelvinator was licensed to build Sikorsky helicopters for the Army, and expected to be in production in quantity during 1944.

The Sikorsky helicopter was 2-place, had a 180 h.p. Warner engine, 2,530 lbs. gross weight, 2,011 lbs. net weight, 38 ft. diam. three main rotor blades and 7 ft. 8 in. diam. three anti-torque rotor blades.

Aero Digest named Mr. Sikorsky “the United States citizen making the outstanding contribution to aviation progress” for his development of the helicopter and presented him with the General William E. Mitchell Memorial Award for 1943.

Southern Aircraft Corporation, Dallas, Tex., devoted expanded manufacturing facilities to parts for prime contractors, including Consolidated, Grumman, Martin and Vultee.

Spartan Aircraft Company, Tulsa, Okla., was devoting expanded manufacturing facilities to subcontract work on military planes.

Taylorcraft Aviation Corporation, Alliance, O., produced its L-2 series Army liaison-observation planes. The L-2 airplane, member of the Grasshopper group, was adapted from the company's commercial Model D Tandem Trainer, used in Civilian Pilot Training and War



THE TAYLORCRAFT L-2

One of the Army liaison Grasshopper planes.

Training Service programs. Powered with the 65 h.p. 4-cyl. opposed, aircooled Continental engine and equipped with two-way radio, the L-2 was used primarily by the field artillery for spotting enemy positions and directing artillery fire. It was a high-wing, strut braced, single-engine monoplane of welded steel tubing, fabric covered construction. Since introduction of the military version in the 1941 Army maneuvers, several changes had been made in the L-2. The first modification increased the range of vision by removal of the wood fairing which formed the streamlined back of the Model D, thereby eliminating any obstruction of view from the cabin. This resulted in a more or less flat upper deck. A "blister" of transparent cellulose acetate was then installed to enclose the cabin at the top and rear, extending from the transparent cabin roof at the trailing edges of the wings and terminating in a tapering effect on the upper fuselage deck nearly midway to the tail. It afforded an exceptionally wide range of vision for the observer who sat in a swivel seat in the rear of the cabin. The ships were equipped with two-way radio, including batteries and wind-driven generators. In the latter part of 1943 further changes were made, notably the substitution of closed engine cowls in place of the open cowls previously used and the installation (for the first time on any airplane) of movable "spoilers" in the wings. These spoilers, hinged just back of the leading edge and operated manually by the pilot, proved highly advantageous in facilitating landings in small areas. In raised, or operating, position they had the effect of sharply reducing lift and more than doubling rate of descent. Upon release of the control lever by the pilot, the spoilers retracted into their housings in the top surface of the wings. The Army Air Forces assigned a substantial number of L-2's out of production to various Civil Air Patrol units for use in attracting enlistment of student pilots and for liaison and courier service.

Timm Aircraft Corporation, Los Angeles, Calif., completed an order from the Navy for the Timm plastic plywood trainer, and also completed production on the CG4-A Army glider. Early in 1944 the company was concentrating on subassemblies for various combat planes.

Chance Vought Aircraft Division of United Aircraft Corporation, Stratford, Conn., was at peak production on the F4U Corsair, fast shipboard fighter for the Navy. In the last six months of 1943 practically twice as many Corsairs were turned out at the home plant as were produced in the first six months. In addition, two licensees, Goodyear Aircraft Corporation and Brewster Aeronautical Corporation, began to build Corsairs. The production record at Chance Vought was established despite the fact that in October the Navy raised the number of planes originally scheduled for production at the beginning of the year.

Expansion of floor area, which had been started when the Chance

Vought Aircraft Division was transferred from East Hartford to Stratford in 1939, was continued. This expansion, coupled with the installation of scores of manufacturing improvements, including a conveyor-line system, aided in the steady increase in production. Continuation of the practice of having others handle construction of sub-assemblies and other parts of the Corsair through a well-integrated system of subcontractors and vendors also contributed greatly to the continued production rise.

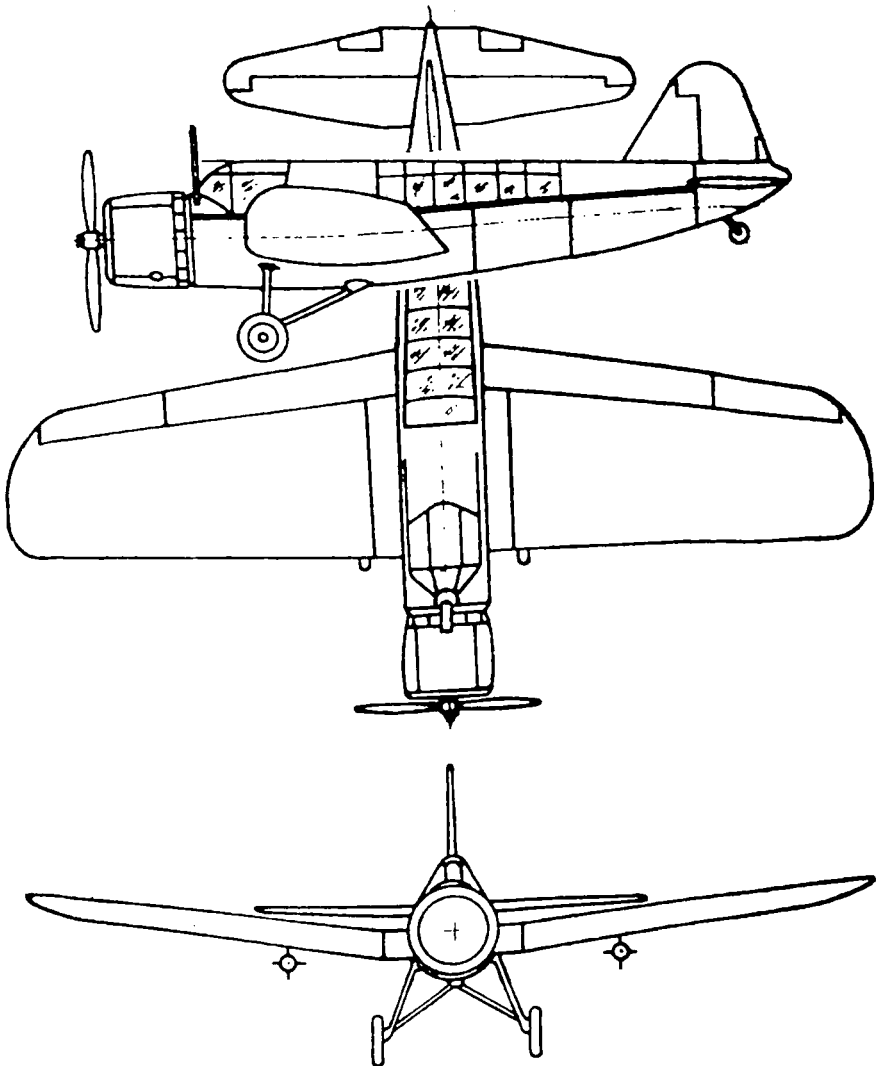

CHANCE VOUGHT KINGFISHER

The OS2U-3, an observation scout, had a Pratt & Whitney Wasp Junior engine.

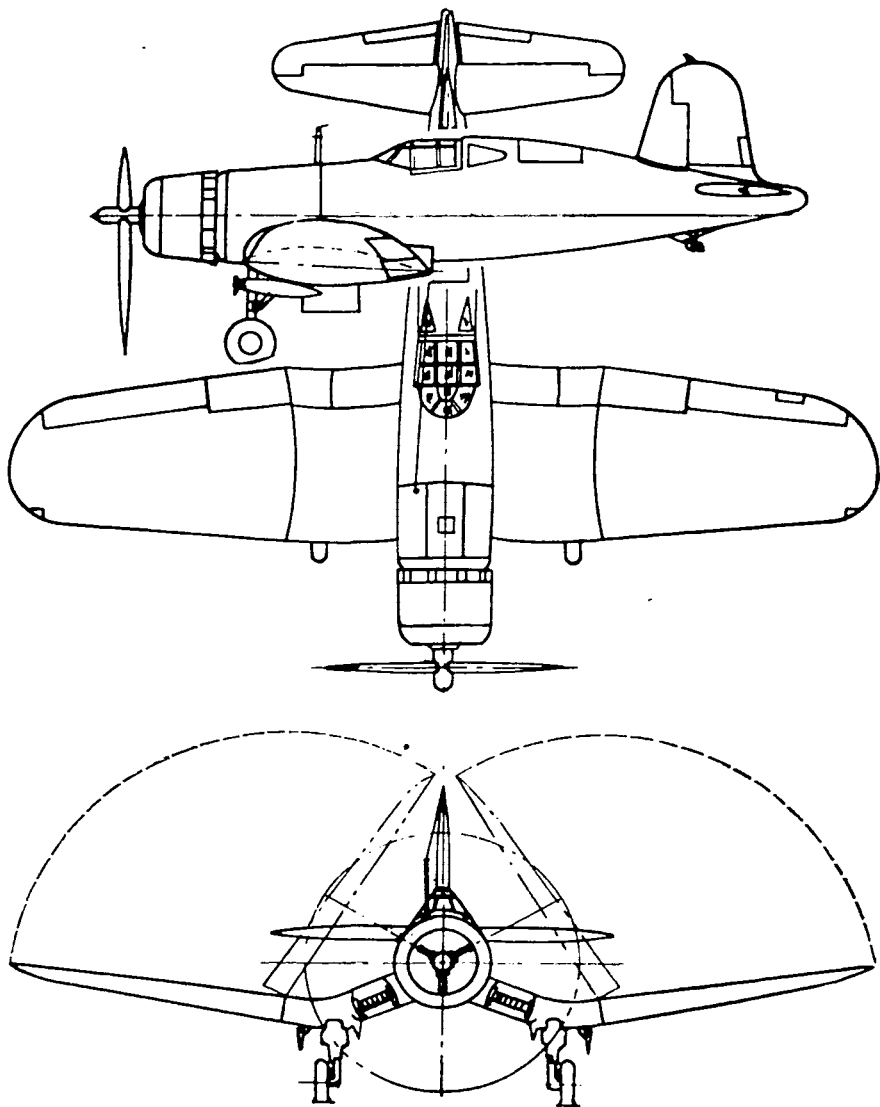

#### CHANCE VOUGHT CORSAIR

This single-seat carrier-based Navy fighter was powered with a Pratt & Whitney double Wasp engine rated at 2,000 h.p.

Reports of the Corsair's effectiveness against the Japs increased as more and more of them went into action. Near the end of 1943 an incomplete compilation showed that more than 500 Japanese planes had been shot down throughout the Southwest Pacific battle area by Marine Corps pilots flying the Corsair. The biggest Jap bag was made by the Hell Hawks squadron with 104 enemy planes to its credit.

The Vought Corsair was in the 400 m.p.h. class, with wing span of

41 ft., length 33 ft. 4 in., height 16 ft. 1 in., service ceiling over 35,000 ft., range over 1,500 mi., carried six .50-cal. machine guns and was powered by a Pratt & Whitney 2,000 h.p. Double Wasp engine and three-blade Hamilton Standard propeller.

The Waco Aircraft Company, Troy, O., devoted its efforts to a variety of war activities, among them the design and production of large Army gliders. In 1942 Waco had designed and built experimentally two large gliders, the CG-3A carrying nine soldiers, and the CG-4A carrying either 15 persons or alternate loads of jeep with crew or field howitzers. These gliders were put into production in the Waco factory and in 15 other factories, aircraft and otherwise. Early in 1944 they were still being built at Waco's Troy plant and in 11 of the other plants working under engineering service agreements with Waco. Another larger cargo glider, the Waco CG-13, was designed and tested, and was in production at other plants.

Design and development of a medium all-wood twin-engine cargo airplane also was in progress with delivery expected in the early spring of 1944. The six hundred Waco UPF-7 secondary trainers and the

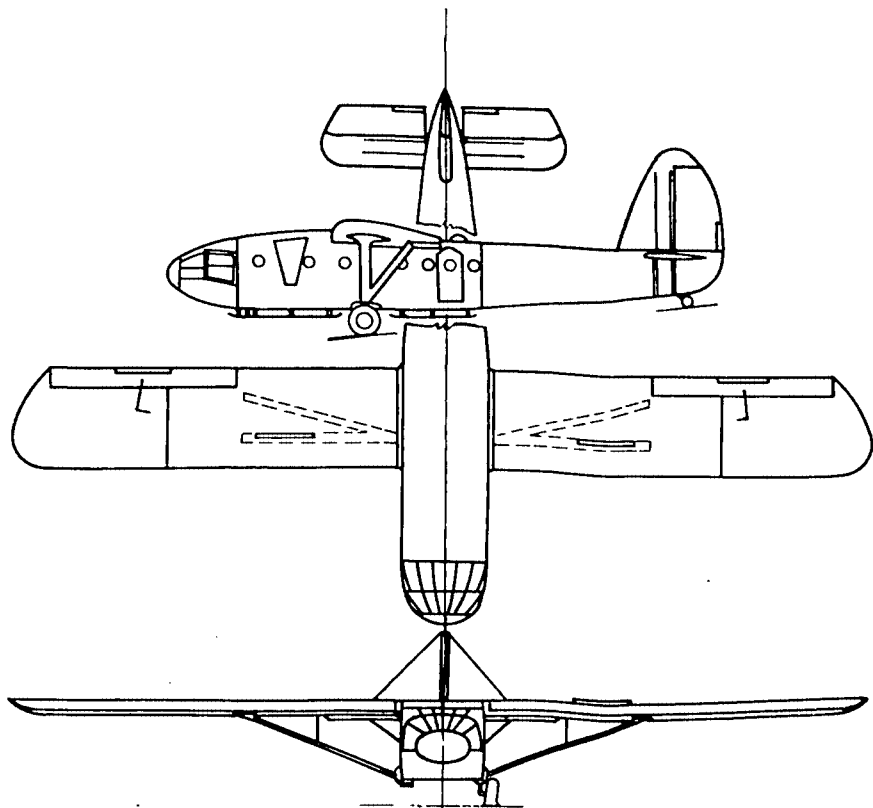

THE WACO CG-13 ARMY CARGO GLIDER





THE WACO CG-13 GLIDER

Developed for the Army Air Forces as both a troop and cargo carrier, this was the third glider designed by Waco for military operations.

many Waco Cross Country cabin models were kept in active service by the Waco Service Division. Other Waco facilities were devoted to subcontracted items for Curtiss P-40's and Republic P-47's; both contracts carrying well into 1944.

During 1943 a new plant adjacent to the present factory was completed and put in operation under a Defense Plant Corporation lease agreement. Both glider and cargo plane contracts were carried on in this building as well as in the company plant.

#### Engine Manufacturers

Aircooled Motors Corp., Syracuse, N. Y., makers of Franklin aircraft engines, continued in military production exclusively, producing Franklin engines of its own design for liaison planes, trainers and for several special military projects. Development work was continued on new service engines, and production was started on several which previously had been in the development stage. In addition to Army and Navy production, orders were undertaken for Franklin engines for War Training Service and for the Brazilian Government. Aircooled Motors also produced a new helicopter engine designed for postwar applications, and already powering several experimental non-military helicopters. Franklin engines were selected to power the Sikorsky helicopters to be built by Nash-Kelvinator for the Army Air Forces. These developments climaxed a four-year history of pioneering in power for rotary wing aircraft, which began when a Franklin engine powered Sikorsky's first successful helicopter, the VS-300.

Allison Division, General Motors Corporation, Indianapolis, Ind., delivered in quantity during 1943, eight models of Allison V-1710-E and F type engines. These models covered the full range of military requirements, including single stage medium altitude, two stage high altitude and single stage for use with turbo superchargers. As in the past, the exclusive Allison features of right and left rotation and extension shaft drives were carried forward at higher power ratings. Military power ratings were increased to give a power weight ratio of .94 lb. per h.p., and combat ratings were established on all models

to give values as low as .81 lbs. per h.p. with regular aircraft fuel. Much higher combat ratings were established with water injection.

Automatic manifold pressure regulation was standard equipment on all model engines, and some were equipped with automatic correlation of manifold pressure and propeller r.p.m. Allison provided those units as standard equipment, adding appreciably to simplification of pilot operation and to factor of safety in engine operation. Added features in remote propeller drives and dual rotation reduction gear boxes were developed.

Additional engineering personnel and development equipment were added, including a large altitude chamber to handle high output, high altitude military engines. New engine test cells were completed. They were large enough to handle complete fighter airplanes. The Allison flight test section was expanded, and considerable test work was conducted on Allison-powered service airplanes. As a result of these flight tests, improved engine installations were obtained, resulting in a decrease in maintenance problems and an increase in airplane per-



#### BUILDING ALLISON ENGINES

First assembly in the plant of the Allison Division of General Motors Corporation at Indianapolis, Ind.

formance, and giving a general increase in overall airplane effectiveness. Considerably greater expansion of the flight test section was planned so that the ultimate in military aircraft performance could be obtained with the Allison engine.

At the beginning of 1944, Allison engines were being produced at the rate of more than 2,500,000 horsepower each month, an increase of more than 50 per cent over 1942. This continuance of an annual sharp production increase each year since the first Allison contract was received, further reflected extensive subcontracting practices. Purchases from more than 1,300 suppliers amounted to more than \$150,000,000. Principal suppliers continued to be Cadillac and Delco-Remy, divisions of General Motors. From Cadillac came more than 250 Allison parts, including crankshafts, connecting rods and gear reduction assemblies. The long background of this motor car manufacturer in precision built products served Allison well in the maintenance of its high quality standards on a product demanding such high standards of workmanship as an aviation engine. Delco-Remy, supplier of aluminum and magnesium castings, brought into production a new plant devoted entirely to aluminum cylinder head castings for Allison. Development work continued at Delco-Remy's Antioch Foundry, a pilot plant for finding and demonstrating new methods in castings practice. In addition Delco-Remy supplied more than 75 different machined parts. Other General Motors divisions supplying parts for Allison included Chevrolet, New Departure, Hyatt Bearing, Delco Products, Packard Electric, A.C. Spark Plug, Harrison Radiator and Inland.

Principal Allison achievement to be released by the Air Forces in 1943 was delivery in volume of an improved type engine for the Lockheed P-38 Lightning. Horsepower rating was increased more than 30 per cent to 1,500 h.p. The Air Forces claimed for the new ship a service ceiling in excess of 40,000 feet and a single engine speed of more than 300 m.p.h. Rate of climb also was increased materially. Development of other newer type engines continued—some of which approached volume proportions at the beginning of 1944. High hopes for outstanding performance in 1944 were held for these models.

Simplification of manufacture continued to be a prime Allison objective, with engineering and management "know how" combining to excellent advantage with the successful workings of an employee suggestion system for which awards as high as \$1,000 War Bonds were presented to nonsupervisory employees. Further progress was made toward reducing the number of piece parts, which in the Allison numbered 700, compared with 2,300 in the most widely known European rival engine. Allison's largest plant unit, built in 1942, came into full production.

As in previous years, Allison in addition to supplying bearings for its own engines, was an important supplier of silver-backed bearings



to several other important engine manufacturers. Allison bearings also were delivered to boat engine builders.

More than 63,000 square feet of floor space were devoted to service training classrooms and other educational facilities. An Army Service Command detachment was maintained in conjunction with the Allison plants, and Allison instructors conducted five week training classes for ground crew mechanics. In addition Allison conducted schools for mechanics in the plants of the four plane builders using Allison engines as well as providing instructors in numerous mobile training units and extension schools throughout this country and abroad. Allison men also circled the globe and could be found in or near every theater of war assisting in field service problems. The Air Forces did not release for publication any new Allison engine installations, but the American-designed Allison liquid cooled engine continued to power the Lockheed Lightning, Bell Airacobra, Curtiss Warhawk and the North American Mustang.

Continental Motors Corporation, Muskegon, Mich., developed and brought out a new line of opposed aircraft engines—Model C, which included 75 and 85 h.p. 4-cyl. and 115, 125, 140 and 150 h.p. 6-cyl. models. Continental also was in active production of the Model A 65 h.p. 4-cyl. engines for the Aeronca, Piper and Taylorcraft Grasshopper liaison planes, and also at peak production of thousands of Continental W 670, 220 h.p. 7-cyl. radial engines for Aeronca, Boeing, Fleet, Howard, Timm and St. Louis Aircraft training machines.

Jacobs Aircraft Engine Company, Pottstown, Pa., concentrated on large-scale production of its L-4 series radial aircooled engines, also continuing production on Jacobs L-6 series engines. These 7-cylinder radial engines powered the majority of twin-engine bomber-



WORKING ON JACOBS AIRCRAFT ENGINES

Old-time metal craftsmen from the Pennsylvania Dutch area burring edges of gear teeth at the Jacobs Aircraft Engine plant at Pottstown, Pa.

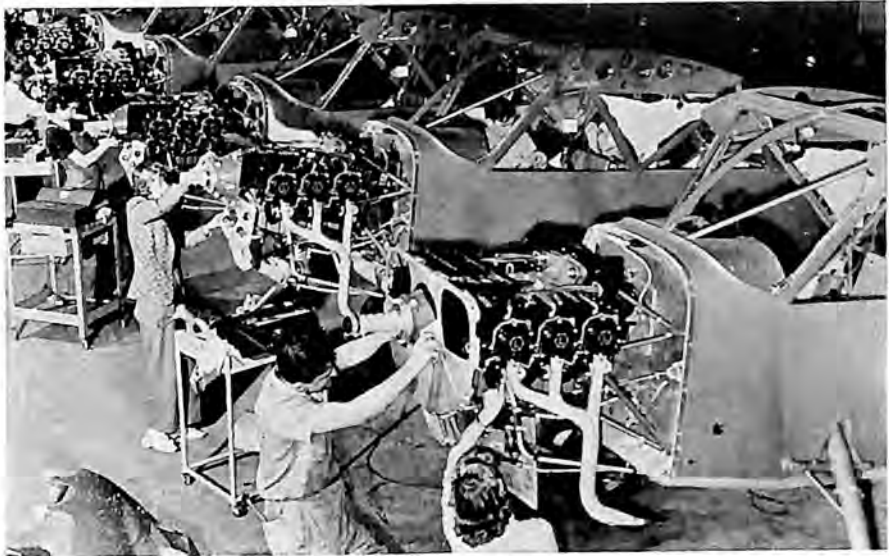

#### LYCOMINGS IN STINSON JEEPS

Installing Lycoming O-435, 6-cyl. 185 h.p. engines in Stinson L-5 Jeep planes.

pilot trainers for the U. S. Army Air Forces and the Royal Canadian Air Force, and a considerable number of light personnel transports for the Army and Navy.

The large new plant built by Jacobs in 1942 for Government account also reached full production in 1943, and large numbers of Jacobs-built Pratt & Whitney Wasp engines were delivered from the Jacobs plant for the Army and Navy and Lend-Lease in 1943. The work force of the new plant was trained almost entirely by the company from employees having little previous experience, and included a very large percentage of women. Particular attention was paid in the plant layout to facilities and working conditions suitable for women workers, and operations were broken down to facilitate the ready acquisition of necessary skills by inexperienced workers.

Kinner Motors, Inc., Glendale, Calif., added the R-56, 160 h.p. aircooled motor to its line of radial engines, and also a new horizontally opposed engine of medium horsepower. The R-56 had an ATC approval, and was installed in the Fairchild 24 and the Meyers OTW. With two plants in operation, Kinner production increased over 1942. Improvements in shop operations and the use of new tools, developed within the plant by Kinner men, speeded production materially. A battery of hydraulic dynamometers installed to check engine run-ins was an innovation. Built by Clayton Manufacturing, these dynamometers proved successful in production of Kinner engines as well as in testing cylinder and cylinder head assemblies which the company produced for Wright Aeronautical Corporation engines.

In all, Kinner built 10 engines ranging from 100 to 350 h.p., although principal production lay in three models, the 125 h.p. B-54, the 160 h.p. R-55 and the new 160 h.p. R-56.

Lycoming Division, The Aviation Corporation, Williamsport, Pa., was at peak production on radial aircooled engines for single and twin-engine primary and advanced military trainers, and also various models of the Lycoming series of horizontally opposed aircooled engines for light trainers, liaison planes and others for Civil Air Patrol activities. Among the new Lycoming engines was a geared 6-cyl. horizontally opposed aircooled engine of 210 h.p. and another engine known as a "packaged power" unit for submerged installation. It was complete even to a selfcooling system, and was adaptable for use in trucks and buses and stationary and semi-stationary installations. Lycoming also was working on a helicopter engine.

Pratt & Whitney Aircraft Division of United Aircraft Corporation, East Hartford, Conn., increased production of aircooled radial engines as two new satellite plants were placed in operation. A new plant at East Longmeadow, Mass., started production in January, 1943, and another at Southington, Conn., started in April, 1943. This completed the satellite program, with five branch plants sending their output to the assembly departments at the home plant in East Hartford. A comprehensive vendor and subcontractor system kept pace with the demands made upon it.

As a result of this coordination of all sources of production, Pratt & Whitney announced the shipment of its one hundred thousandth engine from East Hartford in September, 1943. At that time it was revealed that since May, 1940, Pratt & Whitney Aircraft had produced and shipped one hundred million horsepower while improved methods and increased quantity had resulted in a per horsepower price reduction of 30 per cent.

The production figures were exclusive of the output by the six licensee manufacturers, Ford, Buick, Chevrolet, Nash, Jacobs and Continental, who had built up to full production on the various Pratt



PACKING PRATT & WHITNEY ENGINES



& Whitney models assigned to each. Consequently the schedules for these urgently needed aircooled, radial engines in both single and double-bank models were met and, in some cases, exceeded.

Late in 1943, Pratt & Whitney Aircraft at East Hartford started changeover and retooling involved in producing advanced models of added horsepower. This forward looking program was dedicated to helping the United Nations maintain in the future the air supremacy they had been demonstrating on all fronts. The changeover was in final operation early in 1944, and it increased the horsepower output of the home plant by approximately 50 per cent, based on an increase of personnel from 30 to 40 per cent over the previous high of employment.

Pratt & Whitney in 1943 announced two outstanding developments in connection with its 2,000 h.p. model R-2800, Double Wasp engine. One was the use of a two-speed, two-stage supercharger for altitude performance. The other was the application of a water injection device to make bursts of emergency power available for fighter planes. The device aided cooling, lessened the susceptibility to detonation and permitted the use of a leaner mixture.

At Kansas City, the new plant of the Pratt & Whitney Aircraft Corporation of Missouri was getting into production at the beginning of 1944 to add its quota to the Double Wasp output.

The Division's comprehensive training program was expanded by the establishment of engineering scholarships for young women in nine colleges and universities. Later other groups of qualified young women began in-plant engineering training comparable to the university courses.

Ranger Aircraft Engines Division of Fairchild Engine and Airplane Corporation, Farmingdale, N. Y., utilized its extensive plant facilities to increase production of the Ranger 6- and 12-cyl., inline, inverted, aircooled type engines. The Ranger engines were used by the air forces of the United Nations in the Fairchild Cornell, the Grumman twin-engine Widgeon amphibian (6-cyl. installations), and the new twin-engine, plastic-bonded wood Gunner built by Fairchild using the Duramold process. The Gunner had two 12-cyl. Ranger engines.

The new Ranger plant, with facilities augmented by a second plant in a nearby community, made possible the increased production necessary to fulfill the training plane demands of the Army and Navy air forces. The outlying plant housed small parts machine shop and material supply departments that fed the Farmingdale plant with finished parts and subassemblies. Wherever possible, line production methods were used. Even in several small parts departments and the machine lines that processed castings, straight line methods were employed. Assembly also was carried out in straight lines, with the engines carried on assembly frames pulled by an arrangement of endless

chains laid flush with the assembly floor. Among the special machines in use were 6-spindle Potter and Johnson turret lathes which carried 52 tools and performed 24 operations with only one setup for fabrication of cylinder barrels.

Ranger extended control over casting quality beyond the walls of its factory by providing foundries with a unique checking fixture designed by the production engineering department. The foundry checked the contour of the castings in the fixture and could quickly



#### RANGER AIRCRAFT ENGINES

Ranger six-cylinder engines rolled off the assembly line to this dispersal point where they were routed to the test cells. Each engine had its case history attached, and a complete record accompanied it through the process of testing until it was accepted and prepared for shipment.

ascertain whether or not the metal provided was sufficient for machining operations. More elaborate versions of the fixtures were used at the plant, not only to re-check the foundry's work but also to "layout" the casting. With the fixtures, the first of their type used in the industry, elaborate hand "layouts" were eliminated. Three targeting holes, drilled and countersunk on the fixture, guided all future machining operations, saving many castings and doing the work much more accurately than with older systems.

Another Ranger development was the equipment used in the power driving of stud bolts. Formerly the stud bolts at Ranger, as elsewhere in the industry, were driven by hand. Stud driving equipment used by other industries long ago had proven unsuited for magnesium and aluminum castings. Under the new method, 21 comparatively inexpensive machines built to the specifications of the production engineers drove 90 per cent of the studs used in Ranger aircraft engines. The machinery saved its initial cost every 24 days, and one man could do the work of six, thereby releasing key manpower for other essential jobs.

Many women were employed at both Ranger plants, and one of the most unique jobs that they handled was that of engine testing. After having been especially trained, women were "running in" Ranger aircraft engines for production test.

The Warner Aircraft Corporation, Detroit, Mich., developed and supplied a number of new engines for the Sikorsky helicopters under construction for the Army Air Forces; and at the same time continued production of the Warner Scarab 125 h.p. aircooled radial and the Super-Scarab 145 h.p. engines. Warner also produced its Super-Scarab 165 h.p. engine for the Fairchild C-61 planes. This model had a take-off rating of 175 h.p. with a controllable pitch propeller.

Wright Aeronautical Corporation, Paterson, N. J., maintained production on round-the-clock schedules, including holidays, with all of its plants in full war production throughout the year. With employment nearing a peak, Wright increased production of Cyclone and Whirlwind aircraft engine horsepower in 1943 to a point 3.600 per cent above the horsepower volume when the war began in 1939. Wright Aeronautical began quantity production of the 2,200 h.p. Cyclone 18. This engine powered such planes as the Martin Mars, the Lockheed C-69 Constellation and other military aircraft on the secret list. A new plant built for the production of this engine in Wood-Ridge, N. J., was in full production throughout 1943. In addition, the Cyclone 18 was being produced by the Dodge Chicago Division of the Chrysler Corporation.

The Wright Cyclone 14 aircraft engine was produced in two models in great quantity, both in Paterson and in the Cincinnati, O., plants of the company. The 1,600 h.p. Cyclone powered such planes as the Douglas A-20 Havoc, Martin A-30 Baltimore and the Vultee A-31

Vengeance. The 1,700 h.p. Cyclone was in extremely heavy production for the North American B-25 Mitchell, Vultee A-35 Vengeance, Grumman TBF Avenger and Eastern Aircraft TBM Avenger torpedo bombers, Martin PBM-3 Mariner and the Curtiss SB2C-1 Helldiver. With the highest horsepower rating ever given a nine cylinder engine, the Cyclone 9 was maintained in high production. Additional production of this engine came from the Studebaker Corporation, licensed by Wright Aeronautical to build the Cyclone 9s for Boeing B-17 Flying Fortresses. This engine also powered such planes as the Lockheed A-29 Hudson and the Douglas SBD Dauntless dive bomber.

The Wright Whirlwind 9 was produced in the Paterson plants of the company but was also in heavy production by Continental Motors

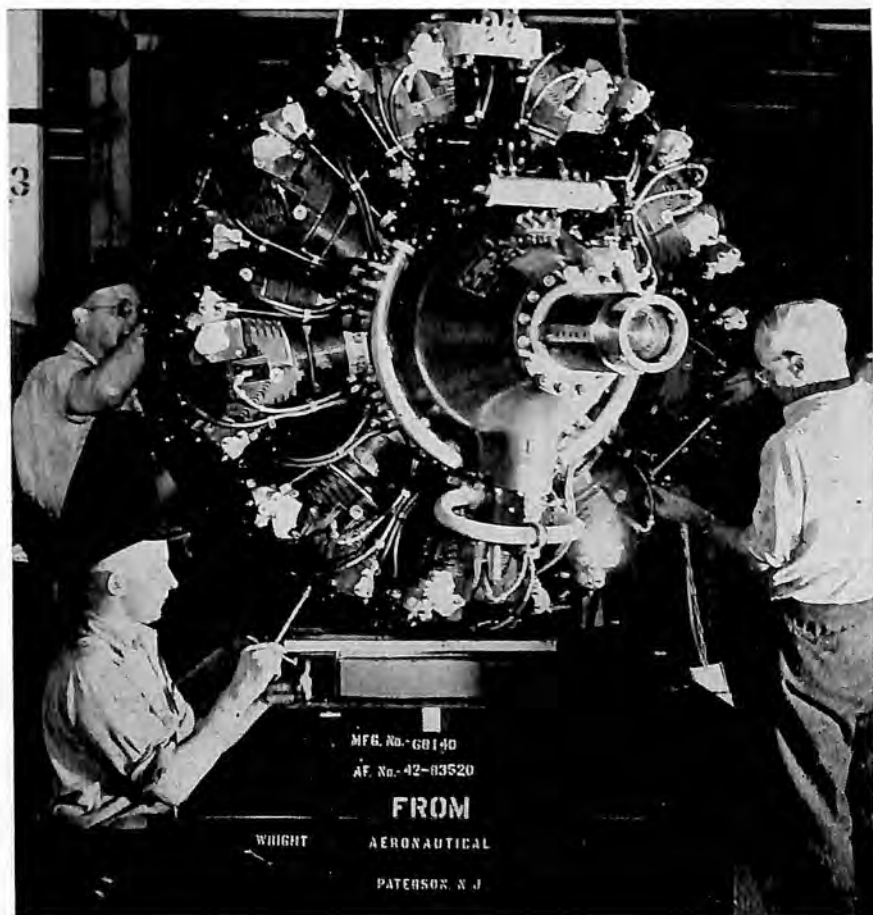

#### THE WRIGHT 2,200 H.P. CYCLONE 18 ENGINE

A Cyclone 18 engine of 2,200 h.p., produced by Wright Aeronautical Corporation, being packed for shipment to an aircraft plant for installation in such planes as the Martin Mars and the Lockheed C-69 Constellation.

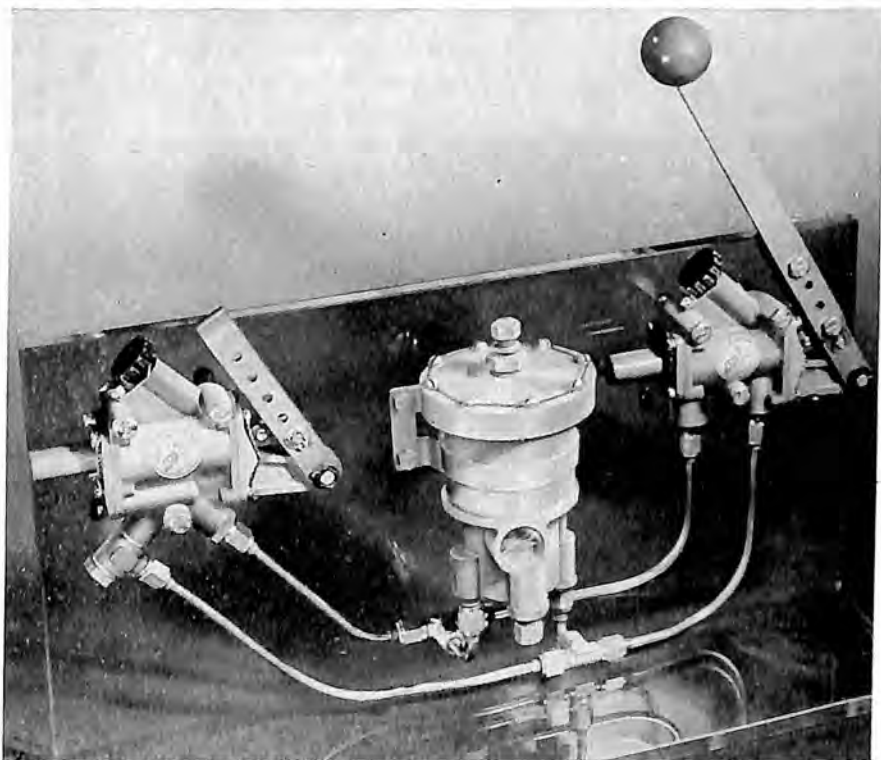

#### ADEL ISODRAULIC REMOTE CONTROL

Designed to offer immediate and precise remote control irrespective of altitude, vibration or pressure fluctuation, and in all temperatures, the Adel system operated independently of the main hydraulic system.

under license agreement, for use in tanks and gun carriers. Adapted to the tank use by the addition of a cooling fan and flywheel, the Whirlwind 9 powered virtually all the M-3 General Grant and M-4 General Sherman medium tanks and the new M-7 105-millimeter gun carrier. The Whirlwind 7, while no longer produced in the Wright plants, was built by the Naval Aircraft Factory, under license, for trainer planes.

Due to the use of high production single purpose machine tools and to new improvements in production engineering, Wright Aeronautical was able in 1943 to introduce new manufacturing techniques which resulted in an annual saving of ten million dollars in materials and over 644,600 manhours.

The employment of women for production jobs was continued throughout the year, particularly to replace men leaving for the armed forces. Over 15,000 former Wright employees were in the Services.

#### Accessories Manufacturers

Acme Pattern & Tool Company, Dayton, O., had an engineering

staff working with the aircraft industry developing processes for breaking production bottlenecks. Among its specialties were heat-treated aluminum castings, patterns, tools and the designing of new tools.

Adel Precision Products Corp., Burbank, Calif., and Huntington, W. Va., completed building programs in both cities, making a total of six plants in operation, and increased production of a number of proprietary articles for aircraft. The Adel ISOdraulic control system provided positive and precise remote control irrespective of altitude, temperature, vibration or pressure fluctuations of main hydraulic system; and it operated independently without requiring integral locks. Additions to the Adel line of Mighty Midget and Stacking Midget hydraulic control valves included a new 6GPH 4-way selector, a 3-way selector and the manifolding Midget for compact multiple control installations. Adel manufactured over 150 hydraulic control valves predicated on six basic design simplicity types with 90 per cent interchangeability. Many of these Adel products provided a basis for Army-Navy standards.

Several new solenoid operated hydraulic valves were developed during the year, including two shut-off valves, a 3-way valve and a 4-way reversing valve and the new Adel 2-coil, 4-way valve.

Increased production of the Adel series J fluid metering pump was augmented by the new series K pump, weighing 2.75 lb., with capacity from 2.5 to 30 gallons per hour. The company's line of filters was increased with a new master micronic oil filter which removed particles of 5 microns and up. 3.800 sq. in. of filtering area were available in a container measuring only 6" in diameter by 8½" in height. Other models included filters of 4" and 6" heights. In the Adel Line Support Division, addition of a number of new model clips and line support blocks brought production to a total of over 12,000 types and sizes.

Aeroproducts Division of General Motors Corporation, Dayton, O., developed the dual rotation propeller and was prepared to start production in 1944 for the Army Air Forces. The propeller was designed for big planes with higher powered engines. The dual rotation propeller, latest of the three and four-blade single rotation, automatic, constant speed Aeroprops already in use on combat planes, featured unit construction and simplicity of installation and maintenance. This feature was a part of the basic design of the Aeroprop which was built with its own self-contained power source, thus eliminating accessory power connections. The company reported production of three and four-blade Aeroprops had tripled the goal which had been set at the end of six years of development. The hollow steel, ribbed blade, which was the basis of the Aeroprop, was strengthened by new brazing methods, and production was doubled. Designs for a negative pitch propeller were also completed. Propellers of various sizes and designs were delivered to the Army and Navy on experimental contracts.



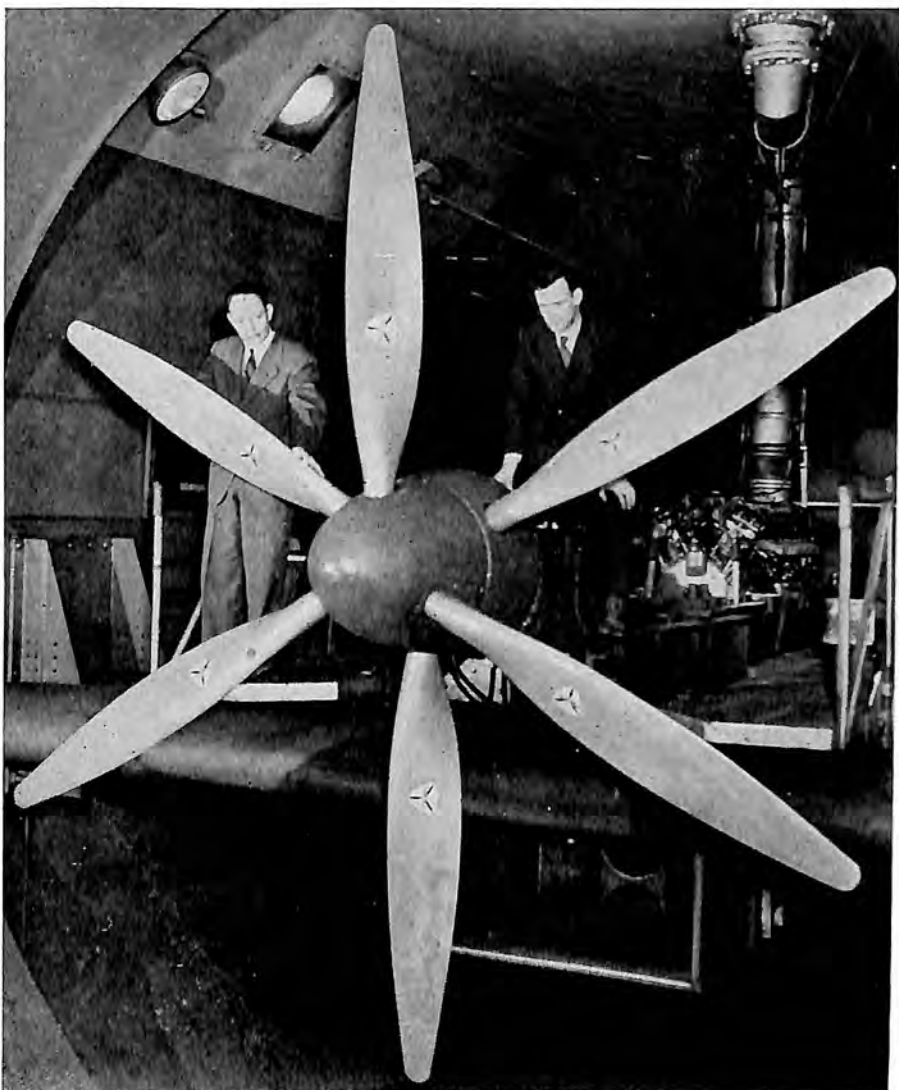

#### AEROPRODUCTS DUAL ROTATION PROPELLER

This automatic, controllable pitch and hydraulically operated propeller, shown here with the designers, K. L. Berninger and T. B. Martin, was produced by Aeroproducts Division of General Motors.

Air Communications, Inc., Kansas City, Mo., produced glide path receivers, marker beacon receivers, aircraft transmitters, command receivers and transmitters, small transmitters up to 1 k.w., interphone equipment, radio telephone equipment and adaptors for radio compasses. One outstanding development was an aircraft automatic direction finder for the Signal Corps. Another was the IAI range receiver

used by TWA. Air Communications also was working on altitude switches used in connection with airborne radio receivers, and other projects of a highly secretive nature for the Signal Corps and Army Air Forces. The company also was doing subcontract machining and assembling of control columns, producing carburetor air scoops, and building technical keyboard assemblies and cables. A flying laboratory was maintained to test manufactured equipment under actual flight conditions.

Aircraft Accessories Corporation, Burbank, Calif., increased production, manufacturing facilities and personnel to keep up with the constantly expanding requirements of the airplane manufacturers. It developed many new products and improved those already in production. A new product was the new AAC Brake Valve for the foot pedal operation of brakes on planes weighing in excess of 12,000 lbs. Other new products included were ultra high frequency radio beam transmitters and precision radio components.

Aircraft Hardware Manufacturing Company, Inc., New York, makers of many types of constructional hardware for aircraft, continued manufacture of its standard line of bolts, nuts and turn-buckles. The firm's stainless steel department was expanded with special screw machine parts and swedging terminals being among the most important items in sales.

Aircraft Mechanics, Inc., Colorado Springs, Colo., produced a large number of welded tubular assemblies and intricate forgings.

Aircraft Radio Corporation, Boonton, N. J., devoted its many years experience in aircraft radio development to production for the Army and Navy air forces.

Aircraft Screw Products Company, Long Island City, New York, substantially increased production of its "Heli-Coil" screw thread inserts, precision-shaped helical coils of stainless steel or phosphor bronze wire, the profile of which engaged screws of the American National system. These inserts provided protection against wear and abrasion of tapped holes in light metals and plastics. They were light in weight, had a small cross-sectional area, and could be installed rapidly with hand or power tools. Other developments included a new type inserting attachment for standard electric and pneumatic power tools and a stud driver for driving and extracting tight-fitting aircraft engine studs having either American National thread form or the Aero-Thread screw thread form. The latter was a truncated vee in the light metal boss and a circular section thread in the screw.

Aircraft Welders, Inc., Wichita, Kans., developed new techniques in airframes fabrication for engine mounts, cowlings, wing and fuselage sections, and other units which promised valuable peacetime applications in fabrication of buckets, barrels, culverts, oil cans, grease cans, air conditioning and airflow ducts. The method was a patented process employing strips of metal and interlocking strips in the spinning ma-

chine, and was different from any method heretofore employed. Aircraft Welders supplied important parts for the B-17 and B-29, the B-32 Liberator and PBV flying boat, the A-25 Helldiver and C-46 Commando, various models of advance trainers built by Beech, Globe, Curtiss-Wright and Waco. Equipment and personnel were built up to the point where every type of welded assembly could be produced efficiently and economically. Many revolutionary methods of welding and machining these critical frames were pioneered by Aircraft Welders with the result that manufacturing costs and percentage of loss in production were reduced to a minimum. Added time savings were accomplished through application of a new and unique technique in machining.

Allied Aviation Corporation, Baltimore, Md., was in production on ailerons for fighter planes, channels for Army gliders and bomber wing flaps.

Alloys Foundry, Inc., Wichita, Kans. supplied aluminum and magnesium castings to principal aircraft manufacturers in all sections of the country. Capacity more than quadruple that of early 1943, coupled with a strategic location in the heart of the United States, enabled the company to meet all delivery schedules. Housed in a new building with modern equipment for both foundry and heat treating departments, the company specialized in castings of superior quality which were inspected through X-Ray, metallurgical and physical laboratories.

Aluminum Company of America, Pittsburgh, Pa., reflected in its activities the rapidly quickening tempo of the war. A host of new plants, capable of handling all phases of aluminum production and



CONVEYOR AT PLANT OF ALLOYS FOUNDRY

fabrication were under construction, including many for the Defense Plant Corporation. It was estimated that when these units were completed and the 1943 peak production reached, there would be a capacity in this country to make 2,100,000,000 pounds of aluminum annually—63 per cent more than the total world production in 1938. Of this total, Aluminum Company of America expected to produce a major portion in its own plants and those leased from the Government. Forging output of the company was 25 times that before the war. Production of castings had multiplied 11 times; extruded shapes and tubing, nine times. A single sheet mill was turning out every month one and a half times as much high strength alloy sheet, such as is used in warplanes, as the whole country used in a year before the war. One of the company's new sheet mills could roll aluminum sheet 50 times faster than in 1940.

The American Chemical Paint Company, Ambler, Pa., was producing chemicals for use in war production, primarily metal cleaning chemicals and allied products, preparatory to final finishes. Company chemists and technicians cooperated with metal fabricators and with the Army and Navy in planning equipment and adapting our products to new and diversified requirements. Laboratory research developed new uses for standard ACP products and new ones to solve many metal treating problems. These developments shortened cleaning operating schedules, enabled fabricators to obtain the chemically clean surfaces necessary for protective finishes, improved and speeded drawing operations, and saved steel by confining the action of pickling baths to the removal of scale. Among the ACP products were the metal cleaners Deoxidine and Deoxylyte, Rodine which limited acid pickling of iron and its alloys to removal of scale, pickle bath toners to improve finish and save acids, Cuprodine (a powdered chemical which when dissolved in dilute sulphuric acid, produced a bright copper coating on steel surfaces). Cuprotek to protect against rust, Lithoform to make paint stick to galvanized iron, Kemick which was a chemical paint for hot surfaces, and many other chemical products.

The American Hard Rubber Company, New York, which developed metal reinforced safety steering wheels for motor cars in the early 1920's, was in production on shock-proof safety control wheels for military aircraft. The light weight of the control wheel was made possible by the use of aluminum reinforcement with plastic molded rims and grips.

American Propeller Corporation, subsidiary of The Aviation Corporation, Toledo, O., developed new methods of forming propeller blades from tubes made in the factory from taper-rolled steel, as well as from seamless steel tubes. The tubes first were flattened in a thousand ton press. An electrically controlled seamless welder fused the tip and trailing edges of the hollow steel propeller blade, which then was heated and the excess metal sheared off in dies.

American Screw Company, Providence, R. I., continued to supply the aircraft industry with wood, machine and sheet metal screws and miscellaneous hardware.

American Tube Bending Company, New Haven, Conn., manufacturers of tubular parts of ferrous and non-ferrous metals, all built to the designs and specifications of its customers, increased production 100 per cent with an increase of 18 per cent in personnel and 30 per cent in productive floor space. Improved inspection methods resulted in a three per cent decrease in parts rejections.

Apex Machine & Tool Company, Dayton, O., manufactured joint socket wrenches, power bits and hand drivers and other specialized tools for aircraft production.

The Aro Equipment Corporation, Bryan and Cleveland, O., continued production of propeller hubs for trainer planes, fluid segregators, vacuum pumps, oxygen demand regulators, special hydraulic assemblies, and also classified projects for the Army Air Forces. The second semester for the Aro Technical School was completed and the third semester started with increased enrollment.

Atlantic India Rubber Works, Inc., Chicago, Ill., was devoting solely to war work its extensive resources and facilities for supplying molded and extruded rubber parts for the manufacturer of aeronautical equipment.

Atlantic Rayon Corporation, Industrial Fabrics Division, New York, was operating on a three-shift basis producing aircraft fabrics under the trade name of Flightex for the Army and Navy air services and the aircraft manufacturers. Among the products was a special fabric for gliders.

Automatic Electric Company, Chicago, Ill., expanded its comprehensive array of electrical control devices and communications equipment specifically designed for aircraft use. The new midget class S control relays represented over 50 years experience in relay design, small size and feather weight  $1\frac{1}{4}$  oz. Designed to meet the gruelling conditions of operation on the fastest combat aircraft, they offered a combination of features. Scientific tests failed to reveal false operation or release of contacts under extreme vibration. They withstood, with a substantial margin of safety, the most rigorous operating tests required for aircraft relays by the Army Signal Corps and Air Forces, including high humidity and extremes of temperature, 40 degrees below to 130 degrees above zero. Independent, self-cleaning twin contacts, mounted on an improved type of spring design, provided additional safeguards. The automatic electric class S aircraft relay proved to be one of the most popular of the series. It had a single operating arm which provided for a maximum of six contact springs, with contacts which would make or break 50 watts (maximum, 1 ampere) non-inductive load, or 25 watts (maximum,  $\frac{1}{2}$  ampere) inductive load. Carrying capacity was 100 watts (maximum,

2 amperes). Other assemblies were manufactured in very large quantities, providing for up to 12 contact springs (two operating arms, 2 oz. maximum weight), with a wide available range of operate and release speeds, and other variable characteristics. Mounting was optional, either by means of screws or standard plug-in arrangements.

The B G Corporation, New York, contributed improvements to the operation of aircraft power plants. The new B G resistor-type spark plug was widely used. By their use, spark plugs functioned continuously between servicings for many times their previous service life. The ceramic ignition wire terminal sleeves, which had been in use for more than a year, were accepted as standard equipment to replace the impregnated paper base type formerly used. Ceramic insulated spark plugs were developed for use in specific aircraft type engines. Work on a flexible, completely sealed, ignition harness passed the development stage, and it was accepted by one of the Services.

B. H. Aircraft Company, Long Island City, N. Y., continued to supply the Government and the aircraft industry with fabricated sheet-metal parts of various kinds and styles.

The Barrett Equipment Company, St. Louis, Mo., manufacturers of precision brake service equipment, have extended its facilities to cover the servicing of all types of aviation brakes. Barrett Aircraft Brake Dokters were used by privately owned aircraft repair shops, as well as by the Army and Navy air forces in their aviation mechanic training shops, and at flying bases on our fighting fronts. The Barrett Aircraft Brake Dokter was a precision brake lining grinder that tailored the brake lining to exact brake drum diameter. It could be used to service all types of airplane brakes, on or off the plane, in the hangar or on the field, on the production line or on the bench. It reduced accidents caused by faulty brakes, kept down brake maintenance cost and saved lining. Another Barrett Brake Service Tool, especially developed for the aviation industry, was the B-35-AC Brake Drum Lathe. With the cooperation of the engineering section of the Air Service Command, this lathe was developed to machine and grind all types of airplane brake drums from the smallest to the largest. The Barrett line also included relining machines, lining clamps, brake drum hones, gauges, mikes, countersinks, drills, master hydraulic cylinder honing sets, hydraulic fluid filler tanks and other equipment for precision servicing of all types of aircraft brakes.

The Bell Company, Inc., Chicago, Ill., produced hydraulic fluids to meet Air Forces specifications. Both mineral oil and castor oil types were available. Bell had accomplished considerable research on hydraulic fluids to operate at extremely low temperatures, and this information was available to the industry.

Belmont Radio Corporation, Chicago, Ill., in 1943 produced for the armed services radio and other types of electronic equipment



equivalent to nearly two million civilian radio sets. In terms of man hours and materials used, Belmont's military production was thrice that of any peacetime year. Most important of all, new standards of efficiency were attained for military radio equipment, which would develop in incredibly finer reception for future peacetime radios.

Bendix Aviation Corporation, Bendix Products Division, Landing Gear Department, South Bend, Ind., manufactured landing gear equipment, including Bendix pneudraulic shock struts, wheels, brakes, master cylinders and power brake valves. A great expansion of facilities was made in step with the war effort. In addition to new facilities in South Bend, a manufacturing unit in Wayne, Mich., was operating to capacity. A number of plants in various parts of the country became subcontractors. Some of these plants manufactured complete assemblies, while others provided parts and subassemblies for the major operating units. More than 50 items of equipment manufactured by this department were standard on planes. Stromberg injection aircraft carburetors, produced by the Stromberg Department, were standard equipment on many American military airplanes. The carburetor had new standards of performance, adding to the safety, speed, maneuverability and range of the plane.

Bendix Aviation Corporation, Pacific Division, North Hollywood, Calif., was in peak production on its line of Altair hydraulic controls and radio accessories.

The Benwood Linze Company, St. Louis, Mo., specialists in the manufacture and application of metallic rectifiers, concentrated on expansion of facilities to increase production and conserve manpower. B-L selenium and copper sulphide rectifiers, as well as complete power supplies, were widely used in aircraft power, control and radio equipment. Many new designs increased efficiency and performance, especially under conditions encountered in aircraft service.

Bolton Manufacturing Corporation, West Haven, Conn., developed shielded ignition assemblies for combat plane, tank and boat engines to drain off spark interference, and they were designed to withstand the strain of war service.

Boots Aircraft Nut Corporation, New Canaan, Conn., was in peak production on its extensive line of standard fastenings for all types of military aircraft, including Boots type all-metal self-locking nuts stamped in one piece from sheet metal.

Boston Insulated Wire & Cable Co., Boston, Mass., continued to manufacture aircraft insulated wires and cables covering the entire range from small instrument wire to motor leads and large power cables. The company produced a wide variety of electrical items used in aircraft, such as bonding cable, shielding braiding, antenna wires, and numerous types of radio cables and cords. Its policy was to supply every type of electrical wire needed by the aircraft manufacturers to facilitate the difficult procurement problems of

purchasing departments. Emphasis was placed on development of specially designed multiconductor cables for electrical instruments and devices which had become such vital parts of combat planes. These types included flexible oil proof and plane proof cables for turrets, gunfire controls, radar instruments and intercommunication, as well as coaxial cables for high frequency circuits.

Breeze Corporations, Newark, N. J., expanded its plant structures, equipment, personnel and research facilities while in production on equipment for aircraft, anti-aircraft, tanks, ships and ground defenses. New developments included a faster and more efficient technique for manufacturing aircraft armor plate which stood exacting tests and gave air crews greater protection and increased confidence. Two types of armor plate for aircraft are made by Breeze—homogeneous and face hardened. Homogeneous armor plate required only heat treatment (heating, quenching and tempering) of alloy steel to give it the high toughness necessary to withstand high explosive shock. Face-hardened armor plate needed special processing before heat treating. It required a thin layer of high carbon case on the projectile striking side which, after heat treating, became hard. With a tough back, this hard surface tended to break up the nose of the striking projectile, thus providing adequate protection against high velocity.

To provide this hard case on face-hardened armor plate, the usual method was to use pack carbonizing, in which the steel was packed in powdered carbon compound. This required a long cycle of carbonizing. Breeze developed a process whereby the steel was heated in furnaces of molten carbonizing salts, in which the face of the steel plate picked up the carbon. This materially reduced the time required to complete the carbonizing cycle. The liquid bath cycle was further shortened by Breeze research to such an extent that the output of the furnaces was greatly increased.

Production of Breeze cartridge type engine starters was further accelerated and a larger type starter was produced to meet the requirements of more powerful engines. The Breeze starter secured its energy from a cartridge using a slow burning fuel to generate the required power at a controlled rate, providing ample torque without damaging the engine parts. This starter made no drain on the airplane batteries, as the current required to fire the cartridge was no more than that supplied by an ordinary flashlight cell.

Further improvements were made in the design and production of Breeze radio ignition shielding for high tension ignition and secondary wiring systems to safeguard the operation of aircraft and insure uninterrupted transmission of vital communications.

A new series of multiple circuit electrical connectors having improved contacts was perfected and produced in accordance with the latest AN specifications. Manufacturers in vast quantities of flexible shielding conduit and fittings, Breeze developed new bench and hand

type swaging machines for use in attaching ferrules to the flexible conduit. Other aircraft accessories on which production was speeded materially included tab controls for operating aileron, rudder and elevator trim tabs, internal tie rods especially adaptable for gliders, flexible tachometer shafts and adapters and remote control drives for radio tuning devices.

Buhl Stamping Company, Detroit, Mich., developed improved methods of stamping and fabricating aircraft parts to the manufacturer's specifications.

California Flyers, Inc., Los Angeles, Calif., was in production on parts and assemblies for military aircraft.

Camloc Fastener Corporation, New York, developed cowl fasteners designed to operate with only a quarter turn of a screwdriver, yet hold sheets securely in place. A floating cam-collar or receptacle permitted spotting tolerances to be increased to over  $\frac{1}{8}$ " in any direction without distortion or warpage.

The Champion Spark Plug Company, Toledo, O., once more expanded its production of ceramic insulated spark plugs to take care of increased war requirements. This involved completion of previously planned plant expansion. Continuous engineering and research development resulted in many improvements in design and materials being put into production. These improvements provided increased spark plug life and more uniform quality. Full utilization of advanced engineering and research facilities assured further developments to meet the increasing severity of aircraft engine service. Increased production was in great measure due to the development of more efficient production equipment and methods, as well as to plant expansion and to greater productive effort on the part of personnel.

Chandler-Evans Corporation of South Meriden, Conn., makers of aircraft engine carburetors, pumps and Protek-Plugs, was acquired by Niles-Bemont-Pond Company, West Hartford, Conn., during 1943. The new CECO carburetor testing plant in Ohio reached its large maximum planned monthly quota for testing CECO carburetors manufactured under subcontract. The South Meriden plant continued to increase monthly production of fuel pumps, water pumps and accessories. The growth of the company's Protek-Plug department was so great that it became necessary to open a third plant in Wallingford, Conn., to handle this activity. The Wallingford plant also housed the company's service department and service school for training domestic and foreign CECO service men and field engineers as well as for familiarization of Army and Navy personnel with CECO products.

Chicago Aerial Survey Company, Chicago, Ill., engaged since 1924 in producing aerial photographic surveys, maps and oblique views, enlarged their manufacturing operations and continued manufacture of the "Sonne" aerial camera, the result of many years of development experience. The company held numerous A.A.F. contracts.

Chicago Wheel & Manufacturing Company, Chicago, Ill., was in peak production on mounted wheels and small grinding wheels for abrasive work, specializing in small sizes of wheels three inches in diameter and smaller.

Clark Trutractor Division of Clark Equipment Company, Battle Creek, Mich., was in peak production on its fork lift truck, a muscular little vehicle that with one person operating it could outwork a whole battalion in lifting, carrying and loading supplies for quick transport to the war fronts. The fork lift truck was a self-propelled vehicle, with little more to it than a motor, a seat for the operator, a heavy counterweight at the rear and a steel pronged fork at the front. At work, the fork was lowered to the floor to pick up the load and carry it away. An ingenious escalator device could raise loads 20 feet or more, so that heavy engines could be installed in aircraft in the shortest possible time and loads stowed away in planes—bombs or cargoes. Fitted for all kinds of service in all branches of the armed forces, these trucks were used by the tens of thousands and were credited officially with having contributed much to the success of operations on all fronts. Fast loading and unloading saved



#### STOWING AIRPLANE CARGO

Loading a Consolidated Vultee Liberator transport with engines and other supplies. Photo shows the fork lift truck developed and manufactured by the Clark Trutractor Division of Clark Equipment Company.

thousands of lives and huge quantities of supplies by shortening the period of exposure to enemy air attacks.

The Cleveland Pneumatic Tool Company, Cleveland, O., manufacturer of aerols (air-oil shock absorbing landing gear units) and Cleco pneumatic tools, was in full production at its newest plant, Cleveland Pneumatic Aerol, a wholly owned subsidiary, in Euclid, O. Devoted exclusively to the manufacture of aerols, this plant, covering about 16 acres, was reputedly the largest of its kind in the world. In addition to the company's increased production of pneumatic tools, sheet holders, rock drills and automotive shock absorbing equipment, new products were added. One was the Cleco RIV-N-JECTOR, a device enabling the riveter to place rivets with a minimum loss of dropped rivets. It was estimated that its use cut rivet loss in some plants as high as 90 per cent. Another development was the Mogul core breaker, an adaptation of existing rock drilling equipment, built for breaking cores from large castings. On castings as large as 14 tons, the Mogul proved to be six to 10 times faster than ordinary methods. A further improvement was made in the standard Cleco sheetholder. On older types, there had been some trouble from occasional breakage and, because of spring construction, a tendency of small component parts to fly in all directions. Slight changes in basic design remedied that condition.

Clifford Manufacturing Company, Boston, Mass., extended its facilities for serving the aircraft industry with basic materials for engine cooling and cooling control. It manufactured the Hydron thin-wall extruded tubing for aircraft radiators, oil coolers, intercoolers and heat interchangers, for liquid and air-cooled engines; and also turned out the Hydron thin-wall hydraulically-formed metallic bellows for use in all types of temperature and pressure control devices for engine cooling systems, carburetors and superchargers.

Consolidated Radio Products Co., Chicago, Ill. has been engaged in peak production of headsets for the Signal Corps, and also was manufacturing transformers with many varied applications. The factory was equipped with the latest machinery, including new tool and die facilities. The company had more than 12 years' experience in supplying the radio industry, and had produced a large percentage of the custom built speakers manufactured before Pearl Harbor.

Cook Electric Company, Chicago, Ill., manufacturers of more than 150 products for aircraft, communications and industrial applications, extended their line of "Aeroelectric" relays and Cook "Spring-life" bellows, and introduced a new line of pressure detector switches. To their line of specially-built relays was added a series of newly designed aircraft relays. The Cook "Spring-life" bellows line was extended to cover sizes ranging from  $\frac{3}{4}$ " O.D. to 6" O.D. A new division was formed, called the "MetaLastic" Division, to produce bellows for heavy duty applications, constructed of heavier metals, such as carbon steel,

monel, stainless steel and inconel, and employing all the known methods of metal joining. From the designing of the "Thermal-Aire" pressure switch, employed extensively in aircraft, a complete series of pressure switches was developed to meet the demands of extremely high or low pressures and capable of being operated by gas, water, steam, oil or hydraulic pressure.

Couse Laboratories, Newark, N. J., continued production of their type A mobile welding shop and type B mobile machine shop for the armed services. These mobile shops were equipped with relatively heavy machine tools to enable them to handle the repair and maintenance work on bulldozers, power shovels, trucks and other large equipment used in building new airfields rapidly at advance bases and permitting quick repair of captured airfields. Couse perfected an entirely new type of power take-off which could be applied to the standard military 6 x 6 chassis without structural changes. It permitted the manufacture of the Couse shops on 6 x 6 chassis for conditions requiring extreme mobility.

Cox and Stevens Aircraft Corporation, Mineola and Great Neck, N. Y., designed and manufactured many types of computers and instruments for the military services and air lines. One was the load adjuster, a slide rule type of instrument, which became a standard device of the Army, Navy and British services for determining proper loading of aircraft. Other products were Intercept officers kits which were standard for the Army and Navy Fighter Commands and in use on aircraft carriers, plotting kits for the Army and Marine Corps, and Model VW and Model S navigational computers. The company developed a standard aircraft electric weighing kit. It had a total weighing capacity of 120,000 lbs., consisting of three weighing cells of 40,000 lbs. each. The cells, the electronic indicating unit and complete accessory weighing equipment were contained in a carrying case, and the total weight of the entire unit was only 70 lbs.

The Ralph C. Coxhead Corporation, New York, developed the Vari-Typer composing machine with hundreds of different styles and type sizes for special report forms, percentage breakdowns, price lists and hundreds of other plant forms for time-saving and elimination of a large part of outside printing costs. The corporation also produced hydraulic gear pumps and selector valves for the air forces.

Crescent Insulated Wire & Cable Co., Trenton, N. J., manufactured for the airplane industry large quantities of electrical wires and cables used in the construction and servicing of airfields and related facilities, as well as for lighting, power and portable cables in aircraft. Crescent's Imperial Neoprene Jacketed Portable Cable and Permacord were heavy duty types of portable cables and cords, giving maximum protection from abrasion, crushing, heat, oils, greases and weathering. They were widely used for portable drills, tools, and other industrial appliances in aircraft factories, and servicing facilities at airfields.



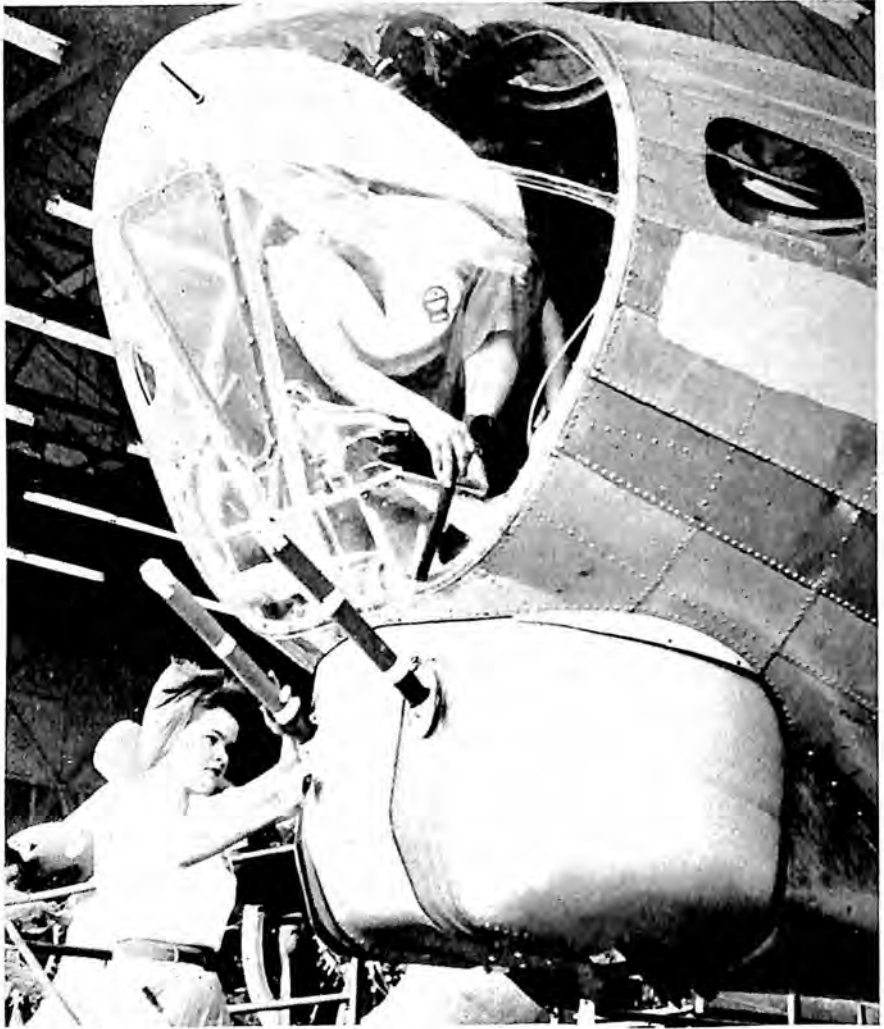

#### HOW CROWN FASTENERS PROTECT BOMBERS

The new power-operated, remote-controlled chin turret on the Boeing B-17G Fortress, showing Crown double acting zippers which close the two .50 cal. machine gun slots and yet permit them to operate at all angles.

Crown Fastener Division of The Spool Cotton Company, New York, developed zipper equipment for protection of the vital parts of combat aircraft. Some of the latest designs of power operated turrets on our bombers introduced new mechanical problems in closing the slots in the path of travel of the guns. Crown Fastener solved the problem for the Army and Navy by developing a double-acting zipper. This small thing was a most important contribution to our successful bombing operations over Germany in the 1944 campaign.

The closure consisted of a carrier shield fitted around the gun barrel. This carrier mounted two zipper sliders on universal joints and facing in opposite directions. As the power actuated gun traversed its path, the zipper opened automatically ahead of the gun and closed behind it. Careful research and design reduced friction loads to a point where only slight power was required to operate the zipper even when it was required to clear itself of ice at low temperatures. Smooth operation in either direction was also a most important factor so that there would be no interruption or roughness in the operation and sighting of the guns in action. The Crown gun slot closure was adapted to a variety of installations. Among the new features was construction of the zippers in predetermined curves so that they could be attached to the contour surface of the turret, thus preserving the aerodynamic efficiency of the turret design. The zipper closure also represented a saving in weight over other known designs of gun slot closures. Crown Fastener also developed a number of other unique zipper designs for aircraft use, including zippers for engine covers, maintenance shelters and other functional applications on combat airplanes.

Curtiss-Wright Corporation, Propeller Division, Caldwell, N. J., increased its output of electric propellers for United Nations' fighting planes approximately 50 per cent over the 1942 production. In terms of horsepower for propellers shipped, based on available engine ratings, the 1943 output was approximately 67,500,000 as compared with 37,836,540 in 1942. These production increases were achieved with an increase of only 20 per cent in the number of employees over 1942. Two of the outstanding features of the experimental and development fields were completion and occupation of a new propeller flight test hangar and a huge propeller test house. In the new propeller test house, all types of propellers were tested at high power. The building comprised two tubular test cells 31 ft. in diameter, with a single glass enclosed control room between them, through which engineers could observe test runs. Propellers up to 30 ft. in diameter could be tested there. The building was of concrete construction with walls over 10 feet thick. A honeycomb of sound-absorbing blocks was built in the open ends of both cells to prevent radiation of noise. Facilities were provided for testing propellers with any type or make of engine manufactured, and they allowed accurate measurement and control of operation on both the engine and propellers being tested, supplying the most complete development data.

Completely equipped with modern testing devices, the new Curtiss flight test hangar was large enough to house six fighter planes. Although military restrictions prevented details of the extensive research being conducted by the Division flight test unit, factors of propeller efficiency were under constant examination. One of the most important tests was directed to the problem of eliminating, or

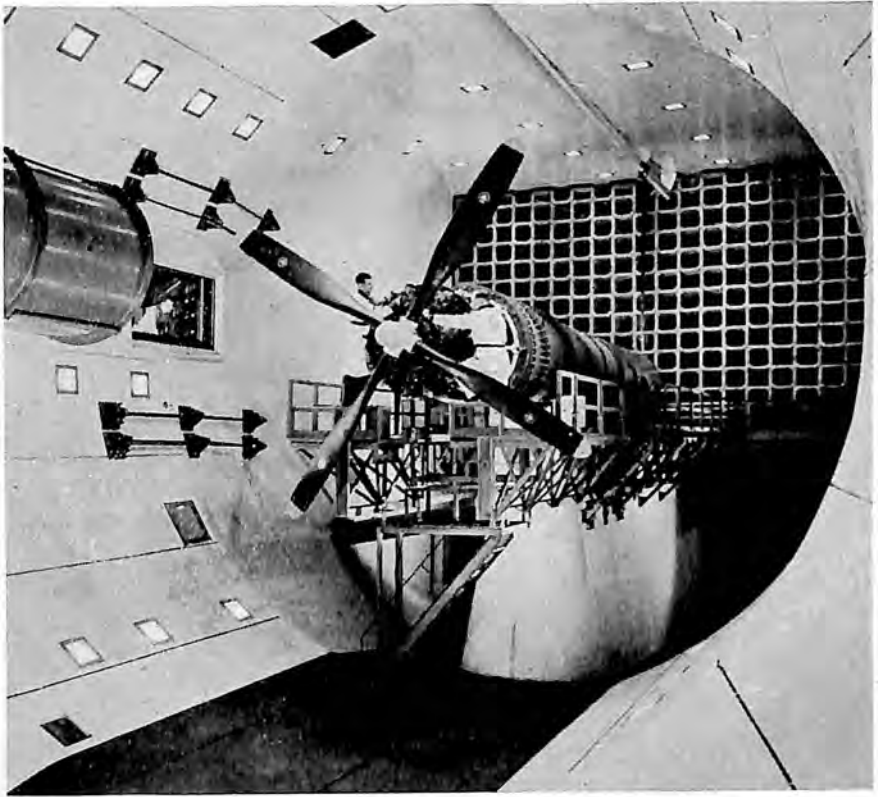

#### CURTISS-WRIGHT'S NEW PROPELLER TEST

An interior view of one of the two cells in the new propeller test house at the plant of the Curtiss-Wright Corporation, Propeller Division, in Caldwell, N. J., with a large four-blade hollow steel electric propeller being prepared for testing.

preventing, ice formation on propeller blades, one of aviation's principal hazards.

In the engineering field the Propeller Division was developing an instrument to enable aircraft engineers to predetermine by flight test available horsepower of a specific airplane engine, thereby opening the way for many improvements and design and performance of propellers. Known as the thrust meter, the instrument, when perfected, would make possible the calculation of horsepower by determining the efficiency of various types of propellers.

Another current development was toward utilization of the propeller for effecting negative thrust during landing operations to assist in braking the landing run. The use of propellers in reverse pitch had been employed on large flying boats for assistance in maneuvering on water for two or three years. Tests with reverse thrust operation of propellers during landing showed that a very rapid deceleration took place and that the combination of reverse propeller and wheel brakes could provide a substantially reduced landing run.

On the production front, several factors figured in the 50 per cent increase in production during 1943. One factor was the conveyerization of the Division's four plants. At Indianapolis, Ind., new facilities went into operation early in 1943. Conveyors also were installed in the headquarters plant at Caldwell, at the Clifton, N. J., plant, and at the Beaver, Pa., plant.

The Army Air Forces also gave recognition to the Curtiss-Wright Propeller Division for its pioneering work in the manufacture of hollow steel blades, and pointed out that the Division had accomplished what no other nation had been able to do—manufacture hollow steel blades for combat airplanes in quantity.

Among the outstanding changes in manufacturing methods initiated by the Propeller Division, which assisted in stepping up the production of propellers, were the introduction of taper rolling of steel plates by the steel mills and the piercing of hub forgings. Prior to this change, the plate stock used in manufacturing steel blades was normally furnished in the form of large uniform thickness plates. The plates were then milled to the required finish thickness where the final weight of the stock of the blade was less than one-fourth the rough stock furnished. The new taper rolled plates resulted in a reduction of 50 per cent in the rough steel required for manufacture of steel blades. Another steel saving practice in the forging of hubs was utilized. The forging companies pierced the hub barrels during the forging operation, with a resultant saving of 40 per cent in steel. The two practices alone saved hundreds of tons of high grade alloy steel monthly. Meanwhile, the steady advancement in improved design, reduced weight of the final product, improved durability, simplicity of construction and proper engine cooling continued. On the latest Curtiss propeller design using hollow steel blades, new features of design resulted in substantial weight savings. One of these features was the new flange type shank and gear used with the blade as compared to the older straight type shank and gear. By shortening the bearing stack and hub barrel length and reducing the blade weight, the total weight for a four-blade propeller was reduced 16 per cent while maintaining equal aerodynamic performance requirements.

The Davison Chemical Corporation, Baltimore, Md., developed a method of preventing corrosion in aircraft engines and other war machines by dehydrated packaging—a system based on the company's pioneering experiments with silica gel. It was known that corrosion would not occur at relative humidities of less than 30 per cent of normal temperatures. Therefore, protection of any equipment would be certain so long as the humidity in the package was held below that figure. Davison developed an absorbent from silica gel and named it Protek-Sorb. Silica gel was a prepared form of silicon dioxide having an extremely porous structure, made by mixing predetermined concentrations of an acid, such as sulfuric,



#### PROTEK ANTI-CORROSION PLUG

Photo shows a Protek plug being removed from the engine of a Republic Thunderbolt. The Protek plug is inserted in place of spark plugs when the engine is shipped to the front or stored.

and a soluble silicate, like sodium silicate (water glass), and allowing the mixture, known as the hydrosol, to set to a jellylike mass called hydrogel. After setting, the hydrogel was broken into small lumps and thoroughly washed to remove excess acid and the salts resulting from the reaction. The washed hydrogel was then dried, crushed and screened to the desired particle size and given a final activation. Protek-Sorb was chemically inert and did not go into solution when saturated; and therefore had no harmful effect on materials with which it came in contact. The action in absorbing vapors was physical. There was no change in the size or shape of the particles as it

became saturated. Likewise, no corrosive or injurious compounds were given off, as was usual with chemical absorption. When saturated, the particles of silica gel appeared perfectly dry. Normal commercial Protek-Sorb silica gel absorbed approximately 50 per cent of its weight of water from saturated air. From this it was estimated that one cubic inch of Protek-Sorb silica gel contained pores having a surface of about 50,000 square feet. Protek-Sorb with this enormous internal surface and infinite number of small diameter capillaries attracted vapors, condensed them, and held them as liquids in its pores or capillaries.

Activated Protek-Sorb silica gel effectively removed moisture from air and readily assured an atmosphere of far less than 30 per cent relative humidity in a package when the correct container or wrapping material was used. Protek plugs were inserted in engines in place of spark plugs during shipment or storage and the entire engine was wrapped in a moisture repellent material, with a bag of Protek-Sorb inside.

Another Davison development was a humidity indicator guide containing especially treated silica gel known as Teltale Gel. Davison impregnated a specially prepared silica gel with cobalt chloride. Theoretically this was simple, but it required long research to arrive at a technique of manufacture that would constantly assure a silica gel indicator that was dependable and that would change color at the relative humidity at which corrosion began. There was every indication that this new dehydrated packaging system which was of such military value in protecting against rust, corrosion, mildew and mold would revolutionize packaging in peacetime.

Denison Engineering Company, Columbus, O., produced its model HSPT3 "hydroilic" spark plug tester, which developed air pressure up to 750 lbs. per sq. in. within 15 sec. and maintained it at least a minute. Testing time averaged only 30 sec. per plug. The plug was seated in an adapter, and action of the cylinder clamped the plug into an air-tight chamber. The desired voltage and pressure were selected, and the action of the plug recorded. Safety features included forcing the operator to move two levers—one with each hand—in opening or closing the clamping mechanism, thus making it impossible for him to have his hands in or about the clamping mechanism where he might be injured. Also, the circuit to the spark plugs was completed only after the plug was clamped into position, and the circuit was automatically broken when the clamp was released. The operator, therefore, could handle the plug in complete safety. The stand was a welded steel frame mounted on swivel casters and equipped with start-stop push buttons, high and low pressure air gauges, low pressure needle valve, adapters, oil level gauge, high voltage connector, low voltage terminal and operating levers.

Diebold Safe & Lock Company, Canton, O., in its 85th year as a



manufacturer of safes and experience in making steel harder as proof against drills, torches, nitroglycerine and other kinds of attack, was in full war production on case-hardened armor plate for aircraft. The company's personnel had increased more than 1,000 per cent in two years.

The Dow Chemical Company, Midland, Mich., was producing approximately half of the country's magnesium output in plants located in Michigan and Texas. In Michigan, where magnesium was manufactured from salt brine, recent expansion in facilities resulted in two new plants, one at Ludington, and the other at Marysville. These plants began production in the spring of 1943. Magnesium made possible greater range, altitude, speed and more payload for America's fighting planes. It was estimated that magnesium in aircraft averaged 1,000 pounds per plane, mostly in the engine and wheel castings. Magnesium also was used in accessory housings and airframe parts. Resultant total weight saving in a bomber was at least 500 pounds. Still other uses were in main landing gear fittings, tail wheel oleo housings and the main auxiliary oil tanks on several of the latest fighters. Another new fighter used magnesium sheet in fairings, doors, flaps and control surface coverings. Dow also built wings for the Navy Bureau of Aeronautics, which were 17 per cent lighter than other types. They successfully passed flight tests and were undergoing extensive service tests. Another Dow magnesium wing, designed with thick skin to attain a more simple structure and a smoother surface, possessed improved aerodynamic qualities.

Dow improvements in fabricating methods and surface finishing treatments resulted in improved service results and in saving of production time. Deep forming draws had to be done hot in the case of magnesium, but that proved to be an advantage rather than a drawback, because the springback problem encountered in cold forming was eliminated. It made possible deep draws in one operation and with a single set of dies. Salt water corrosion of magnesium was reduced sharply by development of superior surface treatments, among them the Dow No. 7 treatment, which was covered by Army and Navy specifications. New types of paints and the development of new alloys in which the iron and nickel contents were practically eliminated also helped to control corrosion.

Welding methods were improved. In the case of arc welding, the shielding of the weld area by an inert helium gas prevented oxidation of the molten material and permitted welding of larger areas than formerly.

The Duramold Division of Fairchild Engine and Airplane Corporation, New York, increased production of wings and tail surfaces for Fairchild trainers made of plastic bonded plywood molded under heat and pressure by the Duramold process. In addition, Duramold was in large-scale production of expendable gas tanks for combat

planes made by the same process. Typical of these was the huge auxiliary tank made for the Douglas A-20 Havoc bomber. It greatly extended the range of this important medium bomber and night fighter. After the contents of the extra tank were exhausted it could be dropped, thus lightening the aircraft and increasing its maneuverability. In line with its policy of continuing research on improved structural materials, better and more lasting finishes, and more efficient methods of fabrication, the Duramold Division in cooperation with the Fairchild Aircraft Division developed and brought into practical application an important new method of heat curing of plastic bonded wood structural assemblies. Termed electronic processing, the method made use of high frequency electric currents which were shot through laminations to cure in a few minutes heavy sections which might otherwise require hours for setting at normal room temperatures. For specific applications, the process offered the advantage not only of speeding production time, but of reducing the number of costly jigs and fixtures and production floor space needed for a given quantity of output. That process was in regular use in

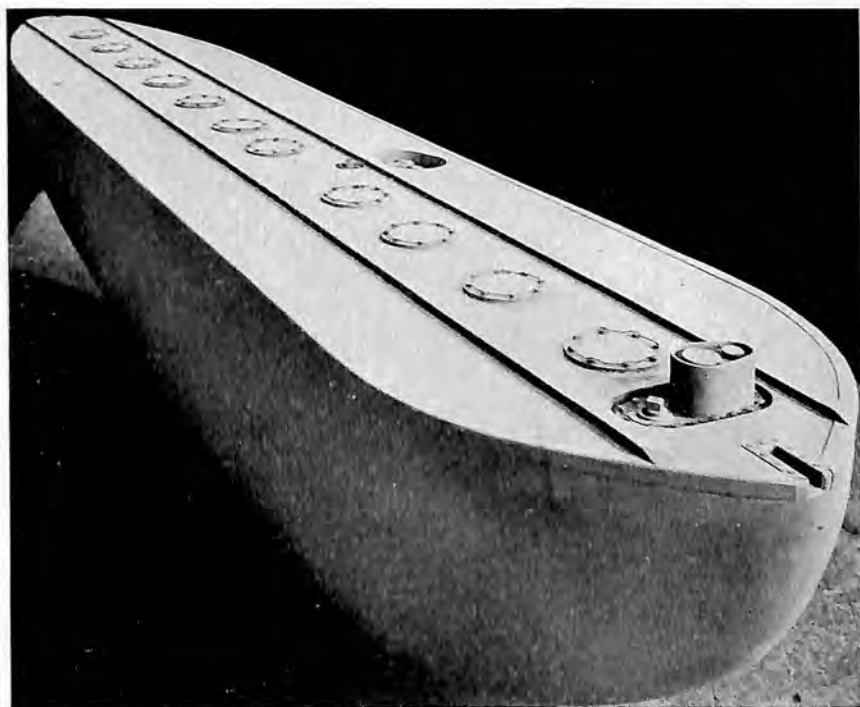

DURAMOLD FUEL TANK

Huge expendable extra fuel tank which could be attached snugly to the belly of a Douglas A-20 Havoc bomber. The tank was manufactured by the Duramold process.

the production of wood spar flanges for the Fairchild AT-21 Gunner and the Fairchild Cornell primary trainer, and for certain reinforcing strips used in the expendable fuel tanks. In connection with the electronic processing, special jigs and fixtures were devised which held assemblies in position with uniform fluid pressure applied by pneumatic tubes to insure thin, strong glue lines essential for maximum strength.

Dzus Fastener Company, Babylon, N. Y., continued to supply the industry with its line of fasteners. The Dzus self-locking fastener was known for its simplicity and dependability.

Eagle Parachute Corporation, Lancaster, Pa., prior to the war was the exclusive supplier of parachutes to the United States Forest Service. These parachutes were chosen because of their special design. The Forest Service found that the steerability feature enabled landings to be made, as one of the instructors put it, "so close to a small fire that all three men and fire could have been enclosed in a 60 foot circle." They found that the minimum-oscillation feature was an important contribution to safety and also that descent was about one-third slower than the rate of standard chutes. After we entered the war, facilities were devoted entirely to the production of parachutes and their spare parts for the Army Air Forces and the Navy Bureau of Aeronautics.

About 50 per cent of production was allocated to each of these two branches, and different models were made for each. The Army-Navy standard program on parachutes did not prove satisfactory. Difference between Army and Navy parachutes involved chiefly pack design and fabric, and harness design and hardware items. Quick-attachable-chest, seat, back and trooper trainer types were fabricated at the Eagle factory, besides spare packs, harnesses and pilot chutes.

The Eastman Kodak Company, Rochester, N. Y., introduced its Matte Transfer Paper to supplant Eastman Matte Transfer Film in the reproduction of drawings and templates. Matte Transfer Paper could be laminated to metal or plywood, forming a sensitized plate to which accurate drawings were transferred by various photographic methods. By this method, templates that formerly required several weeks to lay out were being reproduced in a matter of minutes. With the photographic method of template reproduction, the time between the completion of engineering drawings for a new plane and the test flight of that plane was reduced two to four months. Another outstanding advantage was reduction in template cost. Kodak's new rare-element glass was being used for aerial lenses supplied to the Army Air Forces. Made of tantalum, tungsten and lanthanum, the rare-element glass was the first basic discovery in optical glass since 1886. It had a much higher refractive index than previously available optical glass. The result was a lens giving greater speed without loss of definition and covering power. Eastman continued to supply many types of film, paper and chemicals for aerial photography.

Eclipse-Pioneer, Division of Bendix Aviation Corporation, Teterboro, N. J., continued to step up production of its wide variety of vital aircraft accessories through improved production facilities and utilization of important engineering developments. Eclipse engineers developed a new combination inertia and direct cranking electric starter for engines of 2,000 h.p. or more. In comparison with previous Eclipse designs it was considerably lighter in weight and more powerful. The improved motor design permitted acceleration of the fly-wheel to 24,000 r.p.m. in 15 seconds. In addition, the motor would direct crank at more than 50 r.p.m. under a load of 800 lb. ft. Improved oil sealing at the drive end of the unit, together with a three stage planetary gear reduction, further marked the new starter as being one of the outstanding engineering developments. Many revisions and improvements were applied to the other types of Eclipse starters, and lightweight, semiportable starters for engines of 3,000 h.p. were developed.

Also developed and put in production was a powerful lightweight Eclipse electric aircraft hoist unit with a manual handcrank attachment for either raising or lowering loads in case of electrical power failure, and a quick acting-clutch for stopping and holding the load at any point. Improvement of generators and regulators continued, and in addition, new units were designed and placed in production. Several new type generators delivering both AC and DC were produced, having outputs up to 7,200 watts. Many of the Eclipse DC generators were redesigned, retaining the same output at greatly reduced weights.

Development of a line of high frequency alternators having a range from 50 VA to 50 KVA was carried on and motor generator sets up to 1,200 watts were produced to meet the ever increasing demand for higher power outputs. Acceptance of carbon pile voltage regulators as an improvement in aircraft electrical system regulation resulted in expanding the number of types to meet the requirements of many new applications. The advent of high altitude flights required that booster coils be redesigned, accordingly. Both low and high tension types were redesigned and placed in production.

Recognizing the importance of operating valves and control equipment in attaining more effective ice removal with the new types of inflatable de-icers, development was continued, and many of the latest military airplanes were equipped with the new Eclipse manifold-solenoid de-icers. The system offered distinct advantages. The company was working on the standardization of de-icer systems into two or three basic types for applications to all types of aircraft. A new self-contained electric driven Eclipse roots blower and snap-action distributor combination unit was developed for pursuit aircraft, and it was being applied as the empennage de-icers of large aircraft. An electronic control was perfected for use with the Eclipse

manifold-solenoid system to provide completely flexible control of all phases of de-icer inflation and deflation to suit the particular kind of ice encountered.

Eclipse engine driven air pumps for vacuum operated instruments, and for de-icers, were in quantity production, and engineering effort was directed mainly toward simplification of design and improvement of altitude performance. The application of Eclipse engine driven roots positive air pumps to cabin pressurizing of fighter and small bombardment aircraft was very satisfactory. The inherent ruggedness of design plus the simplicity of the control of airflow on both single and multistage types met with favor. Single and multistage models were given extensive flight tests, and either direct engine driven or electrically driven were available. Experimental units for pressurized altitude suits, pressurized ignition systems, and de-icer operation were designed and undergoing tests.

High output variable speed Eclipse centrifugal blowers complete with controls were placed in quantity production for cabin supercharging of large aircraft. Much was done on development of multistage units in an attempt to keep down speeds, weight and space.

Lightweight, compact fluid metering pumps, for applications requiring accurate metering of all fluids were placed in quantity production. Altitude tests of the original low speed, three gear pump showed superior altitude performance characteristics, and it was finding increasing use on internal combustion heaters where dependable altitude performance was essential. A new Eclipse cabin control valve was developed. Smaller and lighter than existing valves, it had an extremely wide range of control, and would regulate accurately at negligible air flows, making it particularly effective on fighter aircraft where cabin leakage in the past had resulted in difficult control problems. Eclipse continued to supply a complete line of automatic engine controls. Many new problems arose in this field in connection with new engines and new operational problems. Electrical controls were developed. Hydraulic type regulators, with many new control functions, were in increasing demand. Eclipse servo control systems consisting of servo motors with integral autosyn follow-up, autosyn transmitters and amplifiers, all interconnected, were developed to operate from power source of new aircraft. They provided remote, automatic, coordinated control of aircraft main engines, elevators, rudders, flaps, aileron control surfaces or any other function requiring positive straight line or rotary motion with or against opposition to effect an accurate adjustment. New types of electric actuating motors were designed to provide torque for retraction of aircraft landing gear, and operation of bomb bay doors and wing flaps. The reversible electric motors were designed to operate from aircraft power supply systems, and were controlled by suitable solenoid and limit switches.



In addition to the continuing search for improvement of existing designs, Pioneer engineering and research staffs contributed important new optical and electronic instruments; the ultimate goal being completely automatic aircraft operation by means of light weight, all electric devices and controls. An electrically gyro-stabilized driftmeter, and an advanced aircraft octant, with an automatically-recording averaging device, were placed in mass production. The Pioneer gyro flux gate compass, utilizing an electronic amplifier to build up and convert terrestrial magnetic forces into error-free compass indications of direction, was manufactured. A revolutionary automatic navigation instrument, the air position indicator, provided dial indications of latitude and longitude, without need for interpolation or calculation of any kind. The navigator could determine at a glance his position anywhere over the earth's surface. Pioneer's remote-control torque amplifier, an important auxiliary electronic device, was used in several aircraft automatic-control applications. This device picked up the tiniest rotational force at a given point in the airplane, electronically strengthened it, and transmitted it, tremendously intensified, for use wherever required.

The Pioneer automatic pilot, an all-electric control system, coordinated the functions of the gyro flux gate compass, the torque amplifier, the electric turn-and-bank indicator, and a system of electrically-operated aircraft surface controls. Thus it provided complete automatic control of aircraft in flight.

Edo Aircraft Corporation, College Point, N. Y., besides continuing to supply the armed forces with both twin and single float gear for Navy scout observation planes and several other classes of Navy aircraft, carried on experimental and development work



#### EDO AMPHIBIOUS FLOAT GEAR

A Douglas C-47 Skytrain transport with Edo model 78 float and wheels combination.



on float gear for new type Navy planes. Edo designed, built and delivered two widely divergent sizes of amphibious floats for the Army Air Forces, and both of these models graduated from the experimental stage and were put into production. The development of amphibious float gear on a quadricycle principle was begun just prior to the war, when Edo engineers designed a set for the light plane class. These floats were built and test flown on a 65 h.p. Taylorcraft. The war prevented further peacetime developments but they became of considerable value as prototypes for the larger models subsequently developed for the Army Air Forces.

In these light plane Edo floats, the wheels retracted into a well in the centerline of the float. In the down position they were slightly aft of the center of gravity. Nonretractable bow skids were fitted with shock absorbers and nonabrasive shoes. The shoes were hinged and held in a nose up position by springs when not under load. This permitted them to work over or follow rough ground. The proportions and angle of attack of the skids were carefully worked out by tests to avoid any tendency to dig into the water, even when contact was made at high speed. The bow skids proved to be exceedingly satisfactory, both on land and water, for floats of this size; and they had the advantage of simplicity and lightness. In larger Air Forces versions of these quadricycle amphibious floats, the non retractable bow skids were replaced by retractable swiveling bow wheels, which retracted into wells fully closed by doors when the wheels were up, and partly closed when they were down. In the case of the amphibious floats on the Stinson Vigilant, liaison and ambulance plane, the wheels were electrically retracted, whereas on the Douglas C-47 Skytrain they were retracted hydraulically. The model 78 floats on the C-47 were the largest ever built and flown in this country.

Both the Edo model 77 and 78 float installations embodied an electrically operated wheel position indicator and warning device, the former a conventional, visual indicator, the latter an Edo development. It combined a warning horn and a selector switch. Before each landing it was necessary for the pilot to set the selector switch for the condition of landing, water or land, which he wished to make, or else the horn operated as soon as the throttle was closed. If too long an interval elapsed after setting the switch before closing the throttle, the horn also would operate if the switch was not reset. If the wheels were not in the position as selected by the switch, the horn also sounded. For its purpose it was the most foolproof indicator yet devised.

Eisemann Corporation, Brooklyn, N. Y., expanded production of its Model LA Magneto, designed to meet the demand for a radio shielded magneto. It was encased in an aluminum housing, and among the features incorporated in it was a protected winding with core ends so constructed that a precision fit with the laminated stocks

in the housing was achieved, with the result that greater magnetic efficiency was obtained. Other developments included a breaker which permitted easy adjustment by means of an eccentric screw and a breaker cam which required no lubricating.

The Electric Auto-Lite Company, Toledo, O., was in production on a number of items for use in the aircraft manufacturing industry, including spark plugs, power, lighting and instrument wire, booster coils, current relays, generators, stampings, molded plastics, instruments and gauges, instruction plates, ignition cable, batteries, die castings and gun firing solenoids.

Engineering and Research Corporation, Riverdale, Md., was in production on several secret devices for the Army and Navy, and was supplying aircraft manufacturers with its special line of Erco sheet metal working machinery, including automatic punching and riveting machines, hydraulic stretching presses, shrinkers and stretchers, sheet metal formers and propeller profiling machines.

The Exact Weight Scale Company, Columbus, O., was in wartime production of scales with mechanical overweight and underweight indication for balancing connecting rods, pistons, propeller blades and other moving parts. The high speed at which war planes were compelled to operate required the closest weight tolerances, especially in the manufacture of moving parts. The Shadowgraph scale, also manufactured by The Exact Weight Scale Company, had a shadow indication and was used for very close industrial weighing, approaching laboratory accuracy on a production basis. It also was used for close balancing of connecting rods, pistons, impregnating valves, controlling molded parts and the production weighing of numerous other parts used in airplanes.

Federal Products Corporation, Providence, R. I., produced dial indicators and dial gages, and new designs continually were being developed to speed up production. They were used in aircraft and other mechanical industries where the trend was to the finest tolerance possible. Federal caliper gages, both inside and outside, were typical examples of this use. They were exceptionally convenient for checking all kinds of dimensions and were adapted especially to general shop use. Jaws of various capacities and shapes, other than the standard jaws, were supplied. Special contacts of different shapes and of varying degrees of hardness also were available. Patterns, cores, castings, forgings, plastics, dies and sheet material, were among hundreds of products checked with these gages. Federal also produced comparators, depth gages, grinding gages, hole and bore gages, adjustable snap gages, thickness gages and thread gages.

Fenwal Incorporated, Ashland, Mass., produced two different types of aircraft fire alarm apparatus. One was the continuous type, a fusible alloy tube, copperplated, with inorganic insulating beads supporting a conductor wire. If flame struck the alloy, it would melt



#### FIRESTONE LIFE RAFT

It was designed to keep an entire bomber crew of seven afloat, and was equipped with paddles, first aid kit, signalling equipment, raft repair materials, fishing tackle and emergency rations, including chocolate, malted milk tablets, canned beef and fresh water.

it and fill the spaces between the beads, complete an electric circuit and thereby give warning by light or bell. The other alarm type used the Fenwal thermoswitch in which the fire detecting unit was based on an expanding shell separating two silver contacts.

The Firestone Tire & Rubber Company, Akron, O., was at peak production on wing panels and subassemblies for the Curtiss-Wright C-46 Commando transport planes, autogiros and troop-carrying invasion gliders, as well as a wide variety of vital parts and accessories used on practically every type of bomber, fighter and transport plane. Recent contributions to the aviation industry included a new caterpillar-type landing gear, an air spring strut, shatter-proof high-altitude oxygen tanks, low profile nose wheels, channel tread tires, seadrome mooring and contact lighting buoys, and a host of others.

Firestone's channel tread airplane tires had high projecting shoulders and extra wide tread. They gave as many as 600 landings on the Bell Airacobra pursuit plane. The wide, almost flat channel tread, with its undulating contour of special design, made all over contact with the ground in landing, provided greater flotation on soft fields,

improved the speed and efficiency of the braking action, and actually packed loose soil and sand under the tire. On high speed pursuit planes, it increased tire life by reducing skidding upon severe brake application.

The Flex O Tube Company, Detroit, Mich., was in peak production on Government specified aircraft flexible hose assemblies for oil, fuel, instrument, oxygen, supercharger and hydraulic actuation.

Foote Bros. Gear & Machine Corporation, Chicago, Ill., met the wartime demand for gears of extreme precision for aircraft engines of vastly increased horsepower. Gears of the necessary compactness, possessing the close tolerances required, were actually laboratory products, but the requirements of the world's largest air forces demanded their production on a mass basis. Foote Bros. solved the many problems presented by mass production, as evidenced by the fact that in 1943 more than a million of these high precision aircraft gears were produced in the three plants devoted to their manufacture. The Industrial Gear Division of Foote Bros. produced compact precision gears for turning gun turrets on bombers, raising and lowering undercarriages, and transmitting power to the rotors of helicopters. Gears for marine engines in foreign service were products of that division. A more recent development of Foote Bros. was the engineering and production of aircraft actuators. The little packages of power had a wide field in aircraft production and the new airplanes being developed were using more actuators to take over operations formerly performed manually.

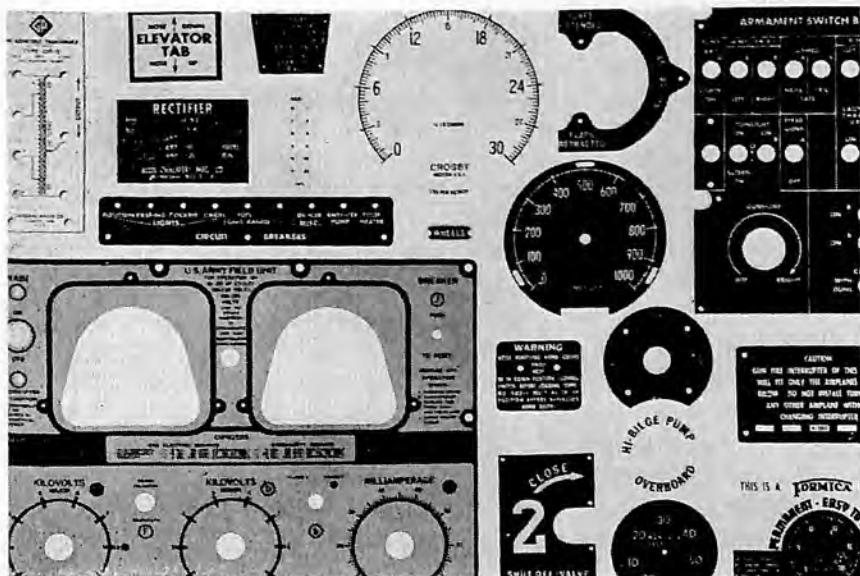

FORMICA AIRCRAFT INSTRUMENT PANELS

The Formica Insulation Company, Cincinnati, O., produced several new grades of materials for aircraft. Its grade CNP-11 forming stock could be shaped by heating the sheet material in a high temperature oven for a short period prior to molding. Grade MF Formica was developed for high frequency applications where only a very low electrical loss was permissible. Grade FF-41 produced a non-burning high arc resistant laminated material which would not support fire, and therefore was of value as instrument board panels. Grade AAA-79 replaced applications where asbestos fabric base grades had been used, and was as strong as the AA material while taking a smoother finish. Formica airplane control pulleys were in mass production. A new factory was added to the Formica plant to produce Pregwood for propeller blades.

The G & O Manufacturing Company, New Haven, Conn., specialists in engine cooling radiators and finned copper radiation, was manufacturing rectangular oil coolers for the air forces. For years, prior to Pearl Harbor, G & O supplied the aircraft industry with oil coolers and this experience proved exceptionally valuable when war brought demands for much greater production and exceptional products to meet various conditions on all fronts. The G & O plant and manufacturing facilities were expanded and the entire organization was working at peak production.

The General Controls Co., Glendale, Calif., developed new magnetic valves known as PV, or AV for aircraft use designed specifically for portable applications. Because of the demand for minimum weight in aircraft, valves were designed to weigh from less than a half pound up, depending upon application. All valves were packless and two wire. They operated in any position and withstood severe vibration. For controlling gasoline, hydraulic and lubricating oil, anti-icing fluid, cabin heating fuel, air or other gases, numerous types of single-way, three- or four-way normally open or closed valves were produced, operating up to pressures of 3,000 p.s.i. Requirements also demanded a control unit withstanding a highly repetitive number of operations. Life tests running into millions of cycles of operation were completed successfully. The company also produced air and liquid cooled engine temperature controls as well as cabin heating controls.

General Electric Company, Schenectady, N. Y., increased manufacturing facilities for the production of a wide variety of accessories utilized in aircraft construction. These products included motors, dynamotors, control devices, voltage regulators and relays, superchargers, switches, wire, radio-transmitting and receiving equipment, magnetos, generators, instruments, and mycalex, a stone-like insulating material. General Electric was in fulltime war production on aeronautical equipment. It paid particular attention to the improvement and increased production of turbosuperchargers so necessary for satisfactory aircraft performance at high altitude. It also increased facili-

ties and improved the design of armament and fire control equipment for protection of high-altitude aircraft.

The General Engineering Company, Buffalo, N. Y., developed an improved model of its automatic multiple riveter which established new records in riveting operations on wing skins, spars, fins, rudders and other heavy subassemblies for aircraft. It had two sets of riveting units which functioned automatically as the work moved through the machine on motorized feed rolls. Power was supplied by an integrally mounted hydraulic pumping system. A single motor operated dual, constant volume, vane type pumps at each end of the drive shaft. Each hydraulic cylinder exerted a maximum force of 56,000 lbs., which was ample for each riveting unit to head six  $\frac{1}{4}$ "  $9 \frac{3}{16}$ " or fifteen  $\frac{5}{32}$ " diameter aluminum alloy rivets per stroke.

Globe Steel Tubes Company, Milwaukee, Wis., developed a new tubing for aircraft parts, named Globeiron, possessing high magnetic permeability, and continued to produce 83 different parts used in aircraft construction, including welded stainless steel tubes named Gloweld, which first were welded and then cold drawn to remove all indication of flash and weld. Globe tubes were made from all alloys, including seamless carbon, alloy and stainless steel. They combined structural strength with adaptability and uniformity, and were machined easily. Metal oxygen bottles for airmen parachuting from high altitudes were made of Globe seamless steel tubing.

The B. F. Goodrich Company, Akron, O., made steady progress in the necessary transition to increase greatly the proportions of synthetic rubber employed in its manufacture of aeronautical products. They included bullet-sealing fuel cells and non-sealing fuel cells, de-icers, tires and tubes, brake expander tubes, all types of aircraft hose, life rafts, oxygen equipment and aeronautical accessories. Early in 1944, nearly all airplane tires were being made with compounds which incorporated varying quantities of synthetic rubber. Many advances in tire construction and design were developed to meet changing needs. For example, tires for special military uses were made with Nylon cords to meet the wartime necessity for overloading planes in many services. A new button type tread design for synthetic rubber bomber tires was introduced. A special high-pressure, smooth contour tire with high channel tread was developed for carrier landings.

A method of attaining prerotation of airplane tires was tested, and tire rotation was brought up to 80 per cent of a plane's airspeed in early tests. Company engineers believed this contribution might eventually increase tire life substantially in some types of service. Goodrich engineers spent months in Arctic regions working in conjunction with the company's cold-testing laboratories in Akron where many essential aeronautic products were developed or improved to meet requirements for operating in lower temperatures. Hydraulic seals, packings, hose and other rubber and synthetic products were in-



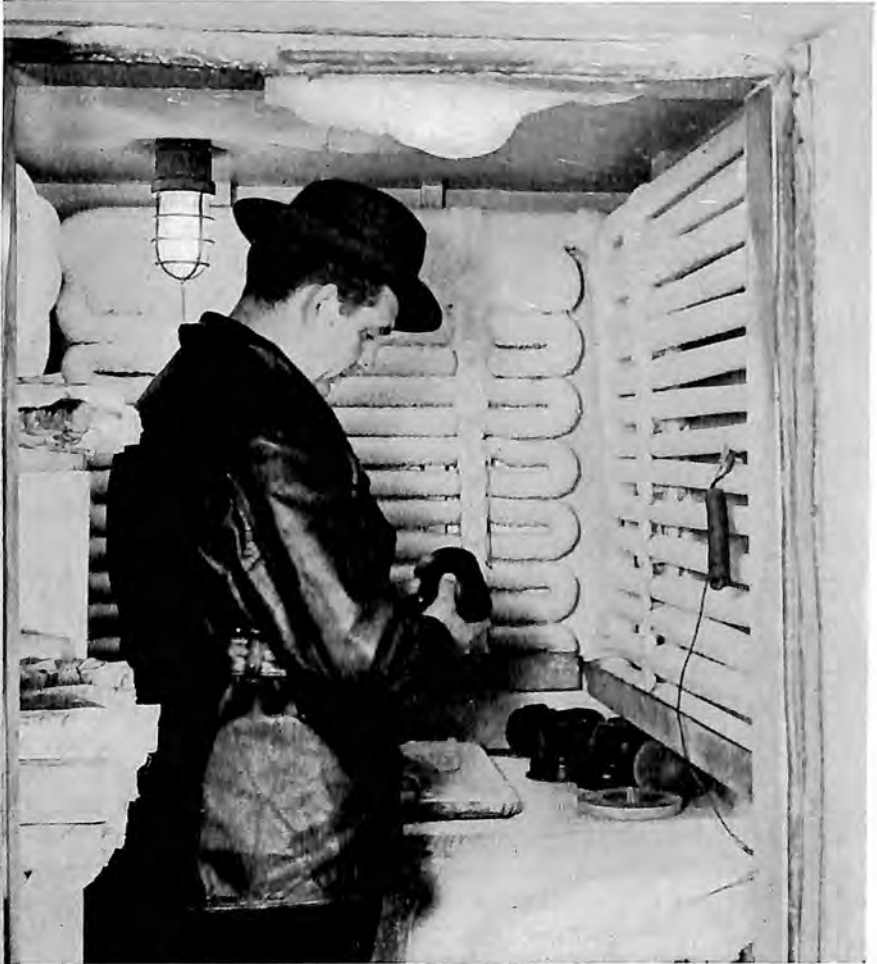

#### COLD ROOM IN B. F. GOODRICH LABORATORIES

Carburetor diaphragms and other products were tested here to temperatures as low as 70 degrees below zero.

cluded in this program. New demands were made on rubber products coming in contact with the aromatic fuels, and compounds for hose, fuel cells and other products were developed to increase life in this type of service. Developments in bullet-sealing fuel cells included an improved type of integral bracing and further adaptations of bullet-sealing cells with integral self-supporting shell. Advances were also made in reducing the amount of natural rubber in the sealant portions of these cells.

Need for an improved method of carrying fuel in integral type wings on non-combatant aircraft was met by construction of a bladder-type cell, which eliminated necessity for caulking off wing areas. It

overcame fire hazards in minor crashes, and solved the problem of fuel leakage from loose rivets or seams. Goodrich de-icer plant capacity was still further enlarged with addition of a new manufacturing unit. Many refinements and developments were made to improve the aerodynamic characteristics of de-icers. Further improvements were made in venting methods. New surfacing materials were developed with decreased ice adhesion, and other changes were made through manifolding tubes and valves to increase effective ice removal.

The B. F. Goodrich Rivnut, originally designed as a blind rivet and nut plate for de-icer attachment, was adapted to many specialized uses in aircraft. It was widely used as a nut plate in cloth-covered wing and tail assemblies. An adaptation of the Rivnut for use as a nut plate in plywood was developed, with a knurled section head to prevent turning. A subsidiary, American Anode, contributed further advances to the development of high altitude masks.

The Govro-Nelson Company, Detroit, Mich., continued at capacity the manufacture of its automatic drilling unit which was in wide use in the aircraft industry. The unit, made in several sizes, was designed primarily for the protection of small drills, particularly where they broke at an angle to the surface or in corners or ribs. By employing the principle of centrifugal force for feed pressure and by regulating the rate of feed through the use of weights, the unit permitted drilling faster than was possible with power feed mechanism which must be set to protect a partially dull drill. Meeting of hard spots in the material or drilling with overly dull tools, did not break the drill.

Graham Rotary File & Tool Company, New York, developed rotary files which came into general use in the aircraft, engine and accessories plants to take the place of hand filing, save time and prevent fatigue among employees, especially women. The rotary files were power tools designed for use with flexible or stationary shaft machines. They were made of high speed steel, Rockwelled to a hardness of 62-64, and drawn down twice in an electric furnace to give their teeth extreme toughness. They would reach any surface, and were used to do work in seconds that formerly took minutes, such as removing scale from cast iron, cutting holes in plexiglas without cracking it, routing grooves in masonite, trimming and countersinking plastics and grinding metals.

The Guiberson Aircraft and Heater Division of Guiberson Diesel Engine Company, Dallas, Tex., added another plant to enlarge its facilities to serve the aircraft industry's greatly expanded Southwestern plants, producing highly specialized parts on a subcontracting basis for Douglas, Lockheed, Boeing, North American, Globe and others. The Guiberson shops were equipped with specially designed machine tools, possessing complete facilities for hydro-press and drop hammer sheet metal forming, stainless steel exhaust manifolds, aluminum alloy fabrication and heat treating, parkerizing and

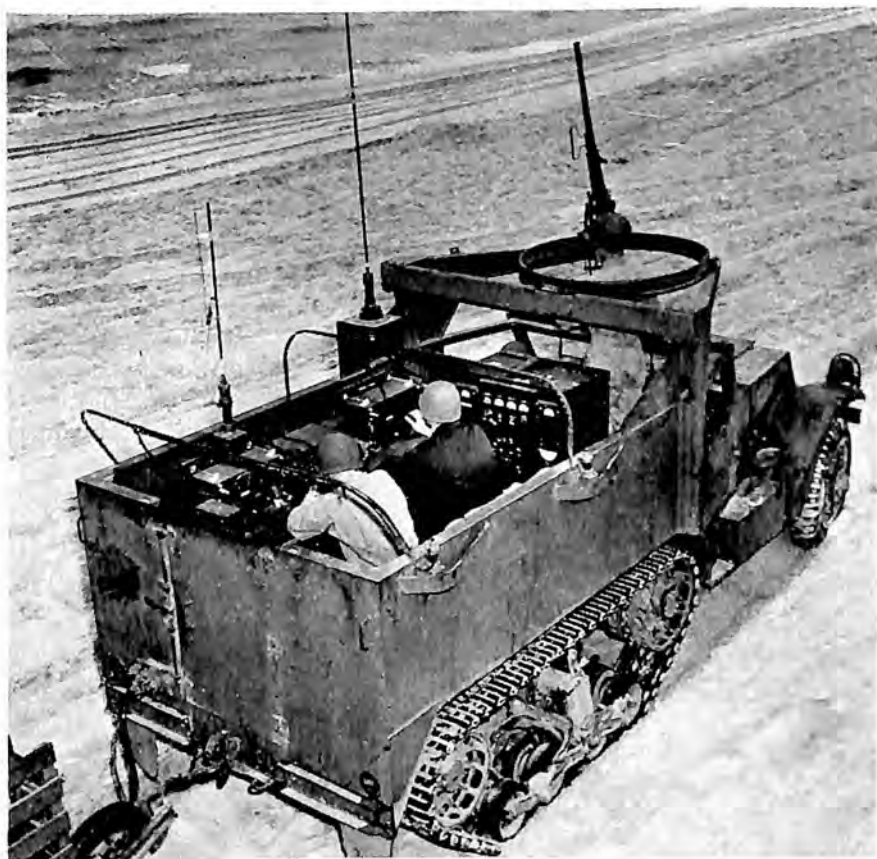

THE HALLCRAFTERS SCR-299

Field radio set in a half track for air liaison communications.

cadmium plating. A wide variety of aircraft parts, from small individual parts to large assemblies, was produced.

The Guiberson Diesel Engine Company expanded its research development program, installing a new and completely equipped single cylinder laboratory and experimental assembly building, and increased its research staff.

The Hallicrafters Company, Chicago, Ill., manufacturers of short-wave radio communications equipment, was responsible for many improvements in constructional details of equipment. Some changes in design were made to expedite production and make possible the use of unskilled help. Others were prompted by reports from the field indicating possible improvements from an operational standpoint. Hallicrafters took over the former Buick plant in Clearing, Ill., making a total of nine factories in the Chicago area operated by the company. The plant was used for the production of the SCR-299

mobile radio communications truck and its variations, the SCR-399 and SCR-499. The assembly line for the BC-610 transmitter, Hallicrafters pre-war Model HT-4, used in this unit, also was located in Clearing.

Completely self-contained in a truck and trailer combination, the SCR-299 was capable of communication by voice or code over distances of several hundred miles day or night. Using the whip antenna mounted on the truck, it transmitted from North Africa to London and with the larger antenna used in semi-permanent locations, it was easily capable of transoceanic communication. Hallicrafters increased production of several of its communications receivers, including Models SX-28, S-36, S-29 and several special purpose receivers. The Hallicrafters S-35 panoramic adapter was used in monitoring activities by the Federal Communications Commission.

Hamilton Standard Propellers Division of United Aircraft Corporation, East Hartford, Conn., continued to supply a heavy proportion of propellers for warplanes. Hamilton Standard had four licensees, Nash-Kelvinator of Lansing, Mich., Frigidaire of Dayton, Ohio, Remington-Rand of Johnson City, N. Y., and Canadian Propellers of Montreal, Canada. The division, with its licensees, celebrated at the end of 1943, the production of the one millionth Hamilton Standard propeller blade, starting from introduction of the controllable propeller, and continuing through constant speed models, including hydromatics and counterweights. New planes introduced during the year with hydromatic installations included the Grumman Hellcat, the revised North American Mustang, the Lockheed Constellation, and a new version of the Republic Thunderbolt. Installations for the Boeing B-29 Superfortress and other new planes also were well advanced.

The Hamilton Standard shadow plant principle, in which each of four plants produced parts for each of the other three, and each plant assembled one or more complete models, was expanded and developed. A new plant at Darlington, R. I., was brought into production less than six months after leasing. The Westerly, R. I., plant produced its 50,000th propeller less than two years after opening, and Norwich, Conn., produced its 25,000th in little more than a year.

Home plant facilities at East Hartford were being altered early in 1944 for new and more highly developed propeller models to incorporate many features hitherto unknown to propeller engineering. The greater part of the manufacture of existing models was removed to the shadow plants.

Production and development engineering continued heavy, both for the Division and its licensees. Instruction of Army and Navy personnel in the propeller training school at Westerly also was expanded, as was the servicing of battle planes on the many war fronts by technical representatives of Hamilton Standard.



#### GIGANTIC PROPELLER FOR BOEING B-29

Huge four-blade hydromatic propeller built by Hamilton Standard Propellers for new Boeing B-29 Superfortress. This was the largest production propeller ever built, having a diameter of nearly 17 feet. It was manufactured by Frigidaire, Dayton, O., under license from Hamilton Standard Propellers Division of United Aircraft Corporation.

Harvey-Wells Communications, Inc., Southbridge, Mass., produced a new air line type radio receiver, the AR-10-A. This equipment resulted from specifications issued by Aeronautical Radio, Inc., which called for a small, light, all-purpose receiver which would be wholly satisfactory to the rigors of air line operation. The receiver met the requirements of the air lines and also improved on the requirements with regard to several design points, including frequency coverage in the beacon band, 195 to 425 kc., continuously variable tuning with provision for quick-shift spot tuning on 278 and 271 kc., or any other two specific frequencies in the beacon band; in the communications band, continuously variable tuning from 2500 to 4500 kc., and from 4500 to 8000 kc., with provision for 12 crystal controlled frequencies anywhere in the 2500 to 10,000 kc. band. All crystal controlled operations were obtained by switching pretuned circuits. One R. F. channel was designed to operate on day frequencies from 4.5 to 10 mc., and the other R. F. channel on night frequencies from 2.5 to 4.5 mc. Weight of the receiver, including crystals, tubes, dynamotor and band change mechanism, was approximately 24 pounds. Two of these receivers could be carried where only one communication or range receiver previously was carried on aircraft.

Haskelite Manufacturing Corporation, Grand Rapids, Mich., had been supplying plywood to the aircraft industry continuously since its products first were used in aircraft during the first world war. Constructions of almost any specified combination of weight, strength and thickness, as well as choice of woods or species and different ratios of ply thicknesses could be supplied by Haskelite engineers in any size required. The Haskelite bonding agent was an infusible, water-resistant phenolic resin, which on setting, produced a bond as strong as the wood itself. Haskelite's newest and most versatile product was Plymold, a molded plywood which could be fabricated over simple dies, either in simple or compound curvature.

Hayes Manufacturing Corporation, Grand Rapids, Mich., producer of aircraft subassemblies, parachutes, ordnance and dies and stampings, concluded its dive bomber outer wing panel production and commenced the fabrication of Flying Fortress tail gunner turrets for several of the leading aircraft manufacturers. It also commenced fabrication of outer wing panels and various control surfaces for an advanced type. Hayes continued to be a large producer of life saving parachutes; and added to this division the manufacture of fragmentation bomb parachutes. Output of afterbody torpedo shell assemblies was increased materially. Hayes continued the fabrication of tools, jigs and metal stampings and completed its preparations for the production in large quantity of a complete truck cab of prime military and postwar importance.

Heath Company, Benton Harbor, Mich., developed important



plastics parts for aircraft, including a plastic bonded plywood float for the Stinson Sentinel, also skis of plastic laminated plywood and steerable tail wheel assemblies. Heath also was a large producer of plexiglas and lucite windshields and cockpit enclosures. The company developed new hot press equipment for turning out landing skids for the CG-4A glider.

Hewitt Rubber Corporation, Aircraft Products Division, Buffalo, N. Y., spent more than two years on development and production of bullet-sealing fuel cells for military aircraft; and early in 1944 its latest development in fuel tanks completed preliminary tests. It was a series of non-metallic crash resistant tanks with weights comparable to aluminum tanks. Tests indicated that the new tank had remarkable resistance to shock and vibration, and was non-leaking. The leak and vibration proof characteristics were due primarily to absence of rivets. The inner lining of the cells was made up of vulcanized, aromatic resistant synthetic rubber. The necessary rigidity and strength were obtained through a combination of fabric and fibrous materials. The tanks could be interchanged with metallic tanks. Hewitt also produced machine gun heater hose and carburetor intake hose of asbestos fabric treated with synthetic rubber, the advantages being flexibility, light weight and heat resistance. Other products included oil, fuel oil and coolant hose made of special synthetic rubber.

E. F. Houghton & Co., Philadelphia, Pa., worked out a new development in shock strut packings of leather and synthetic rubber combined which were of inestimable value to the air services in cold weather operations. The Army Air Forces had discovered that their synthetic rubber packings failed to function properly at low temperatures when idle, permitting leakage of the hydraulic fluid. This endangered the lives of our airmen and threatened loss of valuable equipment, and Houghton undertook development work to solve the problem. It was found that extremely cold weather caused the synthetic rubber packings sealing the cylinder in the shock strut to harden, shrink and fail to respond to actuating pressure. The oil bypassed and leaked out, the struts became flat and of no value for a safe landing. Houghton, with many years experience in making leather packings, found that synthetic rubber of the right type was resilient at higher temperatures, while leather acted as a support for the synthetic material and prevented oil leakage at low temperatures. The leather, too, would not cold-flow or extrude under pressure. Houghton engineers, by direction of the Army Air Forces, checked planes in Canada and Alaska. They proved that the Houghton combination of leather and synthetic rubber packing solved the problem. The leather withstood greater pressures and lower temperatures, while the synthetic rubber withstood higher temperatures and lower pressures.

The Houghton Vim Leather packings, also adopted by the Navy, operated at all temperatures encountered. The packings did not take a

permanent set, and they did not shrink. They had the ability to seal under eccentric loads resulting from the angle of the strut. Impregnated with a synthetic resin, they were impervious to any type of oil used as the hydraulic medium. They withstood pressures up to 16,000 pounds per square inch, and worked well in hot climates. A case was reported from a desert base in which the synthetic rubber packings became twisted in the heat and did not seal; but examination revealed that the two leather packings in the strut were holding the pressure even under highest heat conditions. The Houghton leather packings were used in other places on combat and transport planes where a sure seal against oil leakage was required.

Hub Industries, Inc., Long Island City, New York, formerly Dowty Equipment Corporation, more than quadrupled production on hydraulic pumps utilized for gun turret actuation as well as for lowering and lifting flaps and landing gears. A track landing gear designed for the Army A-20A airplane was developed and successfully flown at Wright Field. Further research on the track laying type of landing gear was undertaken jointly with the Firestone Tire and Rubber Company.

Hyland Machine Company, Dayton, O., was in production on parts for the aircraft industry, including special clips and clamps, various types of manual control assemblies, fork ends, rod ends forged and milled from bar, screw machine and turret lathe products and small stampings.

Industrial Sound Control, Hartford, Conn., engineers and contractors for heat, cold and sound insulation, utilized Soundstone acoustical stone cast in blocks or slabs in treating test cells at the plants of numerous aircraft engine manufacturers. Because of the noises developed during full throttle test of powerful engines and propellers, the noise level in an untreated structure goes as high as 165 decibels. By treating the stacks or flues in the test houses, the firm was able to reduce this noise level to below 100 decibels. The company completed installations at the Pratt and Whitney, Wright Aeronautical, Ranger, Jacobs and Lycoming plants. A low cost standard type test house was in process of development; and the company also was planning to produce a compact, portable unit available to aircraft service stations throughout the country.

International Flare-Signal Division of The Kilgore Manufacturing Company, Tipp City, O., continued on heavy production schedules under war contracts for various types of military pyrotechnics so essential in modern warfare. For many years the Company had specialized in its Tipp City operations on the development and manufacture of pyrotechnic flares and signals for aviation and marine use, and various of its products were standard equipment with the military and maritime services.

Interstate Aircraft and Engineering Corporation, Los Angeles,

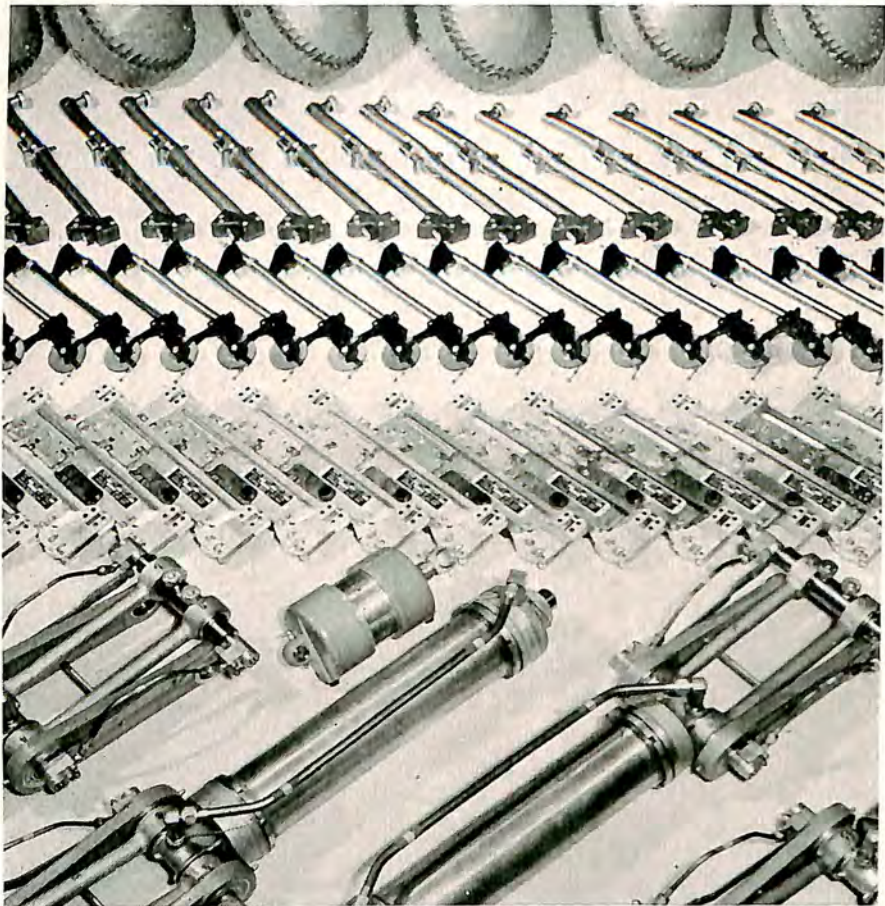

#### PRECISION UNITS FOR AIRCRAFT

A few of the important parts produced by Interstate Aircraft and Engineering Corporation, Los Angeles.

Calif., with aircraft precision units plant in El Segundo, Calif., and a plant in De Kalb, Ill., accelerated the production of precision units such as bomb shackles, machine gun and cannon chargers, hydraulic actuating cylinders, accumulators and hydraulic valves. These units were manufactured to Interstate's own designs or were produced according to the designs of individual companies.

Jacoel Cable Splicing Equipment Company, Buffalo, N. Y., increased production of aircraft cable splicing to five times that of the previous year, using expanded plant facilities and improved techniques that produced 50 per cent more work per employee. The new Jacoel No. 9 machine for one-half to one inch diameter cables was popular with the manufacturers of hoisting slings. Jacoel also developed a precision cable stretching machine for accurate testing of load, which would test four cables in place of the former one.

Jessop Steel Company, Washington, Pa., manufactured many types of steels going directly into the aircraft industry, such as stainless, composite stainless, aircraft sheets, propeller blade quality plate, tool and die steels, shock-resisting steels, nonmagnetic steels and light armor plate for combat aircraft. Light armor plate won for Jessop Steel many citations for the performance of these vital steels under actual battle conditions. The engineering department devised a special type of mill to finish hot rolled propeller blade quality steel to a taper. By supplying these blades already rolled to a taper, much rough machining was eliminated in the shop of the fabricators of hollow propellers, thereby speeding up production.

Jowein, Inc. Aircraft Division, Jamaica, N. Y. manufacturers of Naval aircraft parts and prime and subcontractors for standard and special aircraft assemblies, developed a special process for saving time, labor and cost in the production of strainer, filter and screen assembly units. Increased production necessitated acquisition of three additional plants; for machining, welding and sheet metal fabrication.

Kellogg Switchboard and Supply Company, Chicago, Ill., was at peak production on communications equipment for the armed forces. Much of that equipment was specifically designed for aviation communications, including small capacitors for aircraft radio receivers and transmitters to complete telephone crash alarm systems for installation at airports and ground stations. Throat, hand, desk and palm-type microphones were made in large quantities; also head and chest sets (transmitter and receiver units) for connecting into radio and telephone systems; special aviation headphone receivers with soft rubber ear muffs to keep out extraneous noises; jack boxes and volume control boxes for use with aircraft interphone equipment and other purposes; radio noise filters; rubber covered cords with attached jacks and plugs; multicontact plugs and sockets used in aircraft electrical wiring systems; band switches; expanding and retracting rubber-covered coiled cords for cockpit lamps; capacitors and other component parts for use in aircraft radio receivers and transmitters. Communication equipment for aviation units included manual and relay operated crash alarm telephone systems for use at airports, which made it possible to report accidents from stations located at various points within any given area to a master central station and to service groups. Emergency fire reporting switchboards also were supplied.

Kennametal Inc. of Latrobe, Pa., continued to supply aircraft plants with cutting tools to accelerate the operations of turning, boring and facing of airplane parts, and devised a unique graphical method of analyzing tool wear so that high cutting efficiency could be maintained and the longest possible service life secured. The most recent and rapidly expanding development was Kennametal-tipped milling cutters, available in several sizes, and in the generally-used types. They

had Kennametal tips brazed on sturdy, high grade cast iron or steel bodies. Various grades of carbide were used to suit the character of the material to be milled. Cutting edges were set at positive rake angles, radial and helix, for milling cast iron, nonmetallic, and non-ferrous materials, and at negative angles, to provide greater strength and shock resistance, for milling tough steel alloys. These cutters were developed for high rotary speed operation in conjunction with rapid table feeds. Production was greatly stimulated by their use. A line of stepped fly cutters was to be available in 1944 to provide a simple means of carbide milling of steel within the power limitation of most existing milling machines. These cutters had replacable Kennametal-tipped blades mounted in steel bodies. No cutter grinder was required as the blades were ground to a template on a pedestal grinder. Similar designs of cutters were used effectively in several large aircraft plants, permitting rapid production by inexperienced workers. Another Kennametal development was a lathe file having a generous filing surface of cemented carbide. It permitted revolving work pieces to be filed without reducing the speed at which they were turned with carbide tools. It could not be burned by inexperienced operators, would file steels up to 62 Rockwell C hardness, and often outlasted 50 to 100 steel files on similar work.

The Kent-Moore Organization, Detroit, Mich., for 23 years service engineers to the automotive industry, developed the Aeraligner, a versatile compensating clinometer. Regardless of a plane's position on rough terrain, the Aeraligner checked its specified angles. By the use of a number of readily assembled adaptors, the Aeraligner could be attached to a long, non-sag straight edge for fuselage measurements, to special holders for propeller pitch, and to a clamp for guns. It assured a system of determining soundness of fabric and structure, and proper travel of movable surfaces and guns, whereby periodic check-ups could be speeded. Two types of flaring and beading tools, one portable, hand powered, one hydraulically operated, designed for medium production, also were developed by Kent-Moore. Their specialty was double lap flaring, used by many large aircraft manufacturers because of the stronger neck it gave to the flared tube. The hand tool adapted itself to field repairs, producing a double lap flare with a minimum of effort. The power machine permitted a worker without previous experience to get good results immediately.

Walter Kidde & Company, New York, had in production several new compressed gas safety devices. Among the new products were a light weight, shatterproof oxygen and carbon dioxide cylinder; an oxygen recharging pump for use at advanced field bases where water and power lines were not available; a small inflation cylinder for parachute rafts; a water sensitive device which automatically expelled and inflated the raft stowed in a special compartment on carrier based planes; a pendulum device that automatically set off a plane's fire ex-

tinguishing system in the event of a crash; a carbon dioxide power actuation system which acted as an emergency source of power when the hydraulic system operating bomb bay doors, retractable landing gear, or brakes was damaged; and a carbon dioxide flooding system for explosion proofing wing and fuselage spaces around gasoline tanks. Equipment already in production on which the output was increased vastly included small portable carbon dioxide fire extinguishers for aircraft cabins; built-in carbon dioxide fire extinguishing systems for protecting engine spaces, a vapor dilution system for auxiliary gas tanks; 2,000 lb. capacity carbon dioxide crash trucks for flying fields and air bases; and inflation equipment ranging all the way from tiny carbon dioxide bullets for inflating "Mae West" life vests to cylinders containing three or more pounds of compressed gas used for rubber life-rafts, and water wings and flotation bags large enough to support an entire plane.

The Kilgen Aircraft Division of the Kilgen Organ Company, St. Louis, Mo., was devoting its long experience to plywood fabrication bonded with plastic, and produced a large quantity of precision wood assemblies for the Army Air Forces. Principal work was fabrication of the empennage, interior fittings, lower nose section of the fuselage and other parts for the Army CG-4A glider, wing fairings for the Boeing B-29, a considerable number of subassemblies for the AT-21 and a large quantity of plywood aircraft seats and turret gunner seats. Kilgen developed a new type plastic plywood turret gunner seat for the nose turret for bombers.

The Koehler Aircraft Products Company, Dayton, O., designed and developed a series of oil drain valves, both the Y and straight type. Koehler oil cooler drain valves, using the poppet principle, met all requirements for winterized airplanes, as they operated freely under all temperature ranges, were self locking, required no safety wires and had only two positions. When not in locked open position, they automatically closed, had a large flow area and were lighter than the former Air Forces types.

Kollsman Instrument Division of Square D Company, Elmhurst, N. Y., not only reached full scale output on its regular line of aircraft instruments, but was in production in its new jewel bearing plant as well. Production also continued to increase at the new optical plant where drift sights and binoculars were being turned out in large quantities for the Services. Increasing demand for Kollsman precision motor-like units in the electronics field encouraged further development in this line. Among the new units developed was a rotatable transformer also suitable for use as a phase shifting device, voltage modulator and other applications. Among the new Kollsman developments in aircraft instruments, was a true air speed indicator which compensated itself for changes in temperature and pressure, eliminating the necessity of correcting for these effects. Also developed was a



new combination horsepower indicator and BMEP gauge giving a direct reading of horsepower when the r.p.m. was set in on the dial.

Kropp Forge Aviation Company, a subsidiary of the Kropp Forge Company, Chicago, Ill., operated a complete new plant for airplane forgings. A large battery of drop hammers ranging from 6,000 to 20,000 lbs. was installed, with dual furnace equipment for each hammer, trimming presses and straightening or coining presses for making accurate drop forged airframe parts. All heating and heat treating were under complete laboratory control. A modern laboratory for making complete chemical and metallurgical determinations and photo micrograph studies of test bars was completed and manned by experts. The latest types of inspection equipment were included for making surface determinations, and a new luminous Magnaflux department was added.

Lasalco Inc., St. Louis, Mo., was at peak development on its long line of electroplating and metal finishing equipment, part of which was used in the aircraft industry. One of many new and modified processes applied to aircraft provided for a protective coating of zinc plated parts to prevent formation of white oxide crystals from salt spray. Lasalco full automatic and semi-automatic conveyors for electroplating, anodizing, oxidating, neutralizing, and passivating processes were in general use.

Lawrance Aeronautical Corporation, Linden, N. J., which was formerly the Lawrance Engineering and Research Corporation, specialized in the development and application of equipment to supply the electrical power for airplane accessory operation independent of the main-engine generator. Aware that the increasing number of electrical devices that were used on aircraft demanded electrical requirements beyond what main-engine generators could supply, Lawrance, taking into consideration all aircraft applications and installations, developed several models of aircooled, gasoline driven, light weight Aeroelectric power plants. The U. S. Navy was the first of the Services to utilize Lawrance Aeroelectric power plants on long range patrol bombers, and in the latter part of 1943 the Army Air Forces called on the production facilities of Lawrance for Aeroelectric power plants. Use of Aeroelectric power plants in aircraft was developed so rapidly and successfully that eventually all aircraft of high horsepower would be equipped with Aeroelectric power plants to supply the ever-increasing electrical requirements, the company believed.

In production at the Lawrance plant were Models 30C-2; 30D, 30D-1 and 20A, all two cyl. horizontally opposed, aircooled engines, each operating a 5 K.W. generator. Operation of each model could be controlled remotely without need for continual attention from the crew or flight engineer. Control of r.p.m. was maintained by a governor, restricting engine speed to within the full load and no load range. By use of an altitude carburetor, loads of up to 3 K.W. could be applied

at the rated altitude of 20,000 feet with all but one model. Standard instruments for recording of oil temperatures and pressures, fuel pressure and cylinder head temperatures also were provided to facilitate remote operation. Model 30C-2 was supplied with a sound-box enclosure as was Model 30D-1. Model 30D-1 was so constructed that it could utilize any one of the six standard main engine generators, thereby reducing to a minimum service and overhaul problems at bases and in the field. Model 20A was used by the Army Air Forces in the Boeing B-17 Flying Fortress, and the Consolidated-Vultee B-24 Liberator, with additional Army applications planned. The Martin Mars was equipped with two specially-built Lawrance Aeroelectric power plants, Models 75A and 75C.

Leach Relay Company, Los Angeles, Calif., was at its peak war production of relays suitable for the electrical facilities on military and air line planes, as well as similar equipment for all other branches of the service.

The Leece-Neville Company, Cleveland, O., was producing for aircraft use engine driven direct current voltage regulated electric generators and their companion control units and relay switches in 12 volts, with capacities of 25, 50 and 100 amperes, and in 24 volts with capacities of 25, 50, 100 and 200 amperes. Leece-Neville voltage regulation provided a comparatively high beginning charge rate to a storage battery, then permitted the charge to decrease in proportion to the state of charge of the battery, so that by the time the battery was fully charged, this rate had diminished to a low value that would not harm the fully charged battery. Voltage regulation protected other electrical equipment. The company was in production on vibration absorbing mounting panels for voltage regulators, also direct current electric pump motors in 12 and 24 volts, with capacities from  $\frac{1}{2}$  to  $3\frac{1}{2}$  h.p. for both continuous and intermittent duty.

Leland Electric Company, Dayton, O., manufactured power units including dynamotors, inverters and aircraft motors designed for use with radio and communications equipment.

Liberty Aircraft Products Corporation, Farmingdale, N. Y., manufactured aircraft accessories, precision machine parts, tools, production machine parts to order, screw machine products, milling and gear cutting work, engine cylinders, pistons and crankcases, heat treating and carbonizing in electric furnaces with atmospheric control, cadmium plating and anodizing alloy parts, aircraft sheet metal work, wing assemblies, tail surfaces, pontoons, bomb racks and complete aircraft doping and finishing work. The corporation expanded plant facilities extensively.

Liberty Motors & Engineering Corp., Baltimore, Md., engineers and manufacturers of aircraft test equipment and precision maintenance and overhaul tools, developed type 103 instrument field test set, which was put in general use by the armed forces and commercial

aircraft companies. It was produced in sufficient quantities to justify considerable tooling, resulting in better equipment at lower cost. A new accessory permitted complete testing and calibration of gyro operated instruments, including turn and bank indicators and artificial horizons. With this accessory, the type 103 instrument test set provided for the complete calibration of all types of aircraft instruments with the exception of autosyn and selsyn operated units.

A new instrument field test set, type 110, was specially designed either to wheel out to the plane, or mount on the rear deck of a jeep, between the fenders, for calibration of instruments in aircraft dispersed about a large landing field. It was self-powered by a gasoline engine and in addition to providing facilities for calibrating aircraft instruments, it also provided a compressor for pumping up tires, also DC and single phase and three phase AC power for radio and other electronic testing. Liberty developed additional test units for major overhaul stations, including two new benches for rapid and accurate production testing of aircraft pumps. The type 111 equipment provided for testing aircraft hydraulic and vacuum pumps, the type 113 provided circuits for testing aircraft hydraulic, vacuum and fuel pumps. Both were powered by a 15 h.p. electric motor. By means of a variable speed transmission, pumps could be tested at speeds ranging from 700 to 5,000 r.p.m. Automatic heat control in the fluid reservoirs and complete explosion proofing in the type 113 unit were standard features.

In the field of aircraft overhaul and service tools, Liberty Motors expanded production facilities, and produced large quantities of such tools and fixtures, used in the servicing of Sperry automatic pilots, Chaüdler-Evans carburetors, Pioneer instruments, Continental motors and Scintilla magnetos. The tools and test equipment for Hamilton Standard propellers were redesigned to simplify production and decrease manufacturing cost. Hydromatic propeller test and assembly tables were redesigned to handle the latest models. A new service was provided when Liberty Motors took over the problem of providing overhaul tools for the Rolls-Royce engine manufactured by the Packard Motor Car Company. Liberty produced quantities of overhaul tools for the Merlin engine, and they were made into kits to be shipped out with the engine.

Link Aviation Devices, Inc., Binghamton, N. Y., developed several important pieces of equipment for training airmen. The Link instrument flying trainer was in general use by the Services and civilian organizations. Under the hood of this stubby, miniature aircraft, while still in the classroom, the student was cut off visually from the earth as though the weather had closed in during actual flight and forced him to fly on instruments. Fitted with the conventional controls of an airplane, the trainer provided all the instruments necessary for instrument flight. The student could obtain the knowledge of



#### LINK CELESTIAL NAVIGATION TRAINER

Through the glass nose, the island of Manhattan, a section of Brooklyn and part of the New Jersey coast appear visible to the student navigator in his class room machine. In the Link bombing trainer, an adaptation of the Link celestial navigation trainer, moving photographic mosaics of this type also are employed for locating, identifying and sighting targets. Link mosaic plates cover 250,000 square miles of terrain.

instrument control and master the methods of radio range orientation to be applied when he finally settled at the controls of an airplane for actual flying.

Another device was the Link celestial navigation trainer. Under a dome of synthetic heavens with the principal constellations and the normally visible stars, this reproduction of a bomber nose trained operational flight crews in the coordination so vital to successful missions. Manned by a complete crew, the Link CNT "flew" over moving photographic mosaics of terrain for day problems and was navigated by the stars for night problems. The flight course of the trainers was traced by an automatic recorder on a desk top chart, which moved on three wheels to conform to the trainer's flight and also acted,

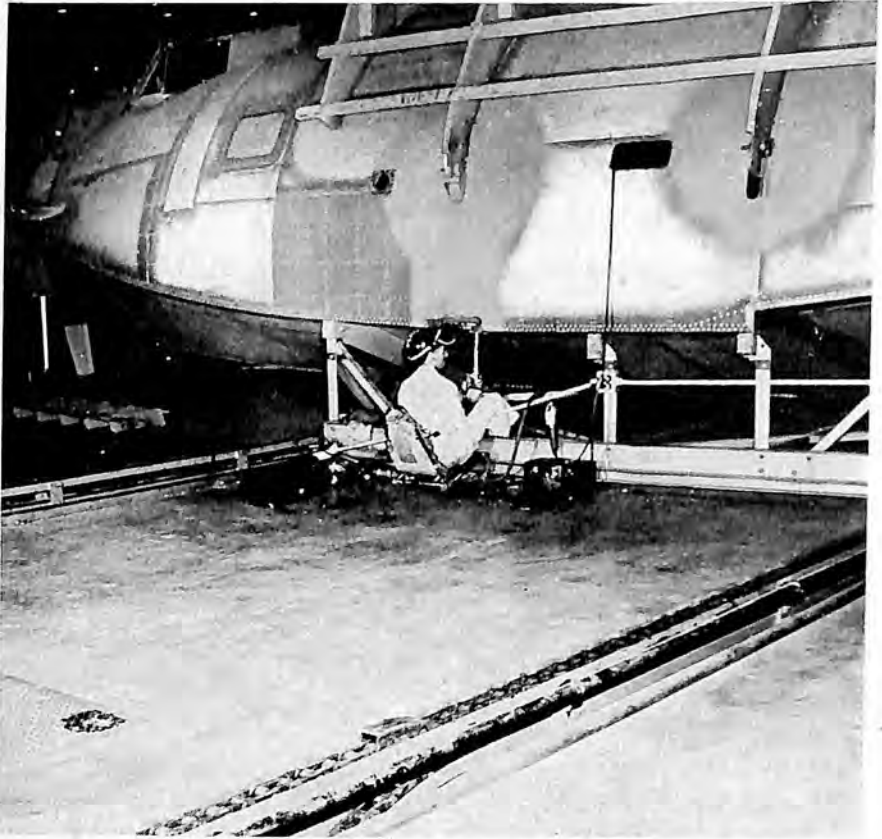

#### LINK-BELT CONVEYOR AT CONSOLIDATED VULTEE

The forward end of a PBY bomber assembly line, showing in foreground one of the two power-operated chains of the Link-Belt conveyor that moved the assembly line ahead as required. Bomber hulls were mounted on padded carriages designed to fit and hold hull in correct position for assembly at flight level.

through its front inking wheel, as a pickup antenna of radio range signals from the instructor's desk. Thus the student could navigate by radio. An adaptation of the navigation trainer was for bombardier students who used bomb sight and automatic pilot to sight targets on the moving photographic mosaics projected to a screen under the glass floor. The Link pre-flight trainer was produced to give new students the "feel" of the controls and the plane's response to them. The Link hydro trainer enabled the student to become familiar with nearly all primary flight training maneuvers. Other Link training devices included the automatic pilot trainer, ground terrain projector, the Link sextant and the Link star globe for instruction in star recognition and celestial navigation.

Link-Belt Company, Chicago, Ill., produced for the aircraft industry an increasing number of overhead trolley conveyors, full plane

assembly line conveyor systems, variable speed test rigs, self-contained electric car spotters (for aircraft mooring) with vertical capstans of 5,000 and 10,000 lbs. starting pull, Link-Belt silent chain drives for control mechanisms, such as that on the Martin Mars, and other facilities for aircraft manufacture and handling. One of the Link-Belt wartime developments was the power-operated conveyor that moved huge combat planes along the assembly line. This combined with the overhead trolley conveyor system to speed up the production of warplanes far beyond the output estimated before Pearl Harbor.

The Liquidometer Corporation, Long Island City, N. Y., continued its production of tank quantity gauges for use on military and commercial aircraft. Liquidometer gauges were used to indicate the quantity of fuel, lubricating oil, de-icer fluid, windshield alcohol, or other liquids in tanks. Its research and development departments again were expanded, resulting in improved, as well as new, instruments.

Littelfuse Incorporated, Chicago, Ill., and El Monte, Calif., continued the manufacture of aircraft fuses and accessories with new and important developments and additions to the line. Two large plants were engineered and staffed for maximum production in circuit protection. Additions to Littelfuse products included the Signalette radium-active fluorescent nonfilament, nonshatterable indicator for use wherever signal lights were required within aircraft; circuit-breakers; thermocouples; fine wire products. Improvements included welding of side terminals of fuse extractor posts, making terminals integral with inside of the shell, and giving greatest protection against vibration, shock and temperatures. Both beryllium copper and phosphor bronze fuse clips were featured, the beryllium copper clips silver-plated when required. Army Littelfuses and anti-vibration Littelfuses, fibre, bakelite or glass enclosed for all aircraft, were protected against surge, shock and vibration (and in the case of aircraft for the Services, shell impact and dive bombing) by the patented Littelfuse locked cap assembly. Fuse caps were affixed so firmly that they could not be separated from the fuse bodies. Fuse elements were hermetically sealed against temperature, moisture and all climatic conditions. Caps were not lost. Mechanical depolarization of the fuse element by twisting at 90 degrees continued to be an essential factor of the strength of Littelfuses. This twist rendered the element unresponsive to vibration from all directions. The non-crystallizing factor was greatly strengthened by the Littelfuse spring-forming at one end of the element, which took up contraction and expansion.

Lord Manufacturing Company, Erie, Pa., developed its RS-40 pedestal type dynafocal suspension for use on double row radial engines; and was carrying on further development of meter mountings for individual instruments. The Lord plant was expanded from 150,000 to 190,000 square feet in 1943. Employment increased from 2,000 to 2,800; and considerable new equipment was added.





#### RADIO ROOM OF THE MARTIN MARS

Showing special seat designed by Warren McArthur Corporation for flight engineers and radio operators.

Lyon-Raymond Corporation, Greene, N. Y., was in full-out war production on aircraft hoisting and servicing equipment, including hydraulic hoists for engines, spotting dollies, elevating cargo-body trailers, mechanical elevating portable cranes, hydraulic elevating tables and open-end lift trucks.

Warren McArthur Corporation, New York, devoted many years to the development of scientifically conceived seats for all members of the crew on our warplanes. It was not a simple problem, because it involved cushioning against shock, irritation, fatiguing pressure and accelerating forces while at the same time providing easily adjustable positions for pilot and the rest of the crew in relation to objects under their control. More than 100 designs of specialized seating were developed, embodying the six fundamental factors recognized as vital in aircraft—the use of aluminum and magnesium to save weight and thus increase payload, a strength-weight ratio that added to length of service, standard replacement of parts, protection of the surfaces against air and salt water, seats designed for minimum space to allow more cargo and supercomfort for crew efficiency. Warren McArthur seats were in practically all important planes.

Macwhyte Company, Kenosha, Wis., expanded production of Macwhyte "Hi-Fatigue" aircraft cables and Macwhyte "Safe-Lock" swaged cable terminals. The cables were made of galvanized and stainless steel, fabricated to reduce constructional stretch and to increase fatigue resisting properties. The swaged cable terminals were made in eye ends, fork ends, stud ends, turnbuckle ends and numerous special types—supplied both loose and attached to the cable. Macwhyte aircraft wire rope slings were lightweight and flexible, and some were built into the plane itself to permit its being hoisted for repairs or shipment. Macwhyte also produced tie rods of cadmium plated carbon steel and corrosion resisting steel for both internal and external bracing of aircraft.

Manufacturers Screw Products, Chicago, Ill., manufacturers of aircraft screws, washers and other fastening devices under the STRONG-HOLD trademark, made considerable headway in increasing production facilities and in perfecting new production techniques. More notable among the latter was the successful fabrication of the perfection in miniature #0-80 (.060 diameter) and #1-72 (.073 diameter) aviation machine screws in brass and steel. In addition, considerable success was achieved in the fabrication of steel and brass collar and other special studs by the cold-heading process, with resultant saving in time, material manhours and machine running time. The company produced the popular AN and AC fastening devices in steel, brass, stainless steel and aluminum, with a large stock of regular and special sizes, dimensions and lengths. As an added service to the aircraft industry, the periodical STRONGHOLD "In Stock" record of AN and AC fasteners, giving up-to-the-minute stock information on standard and hard-to-get aircraft parts, went to purchasing agents and buyers in the principal aircraft plants of the country, a service which aided materially in expediting parts.

Mercury Aircraft Inc., Hammondsport, N. Y., manufactured parts and accessories, one of its three plants being devoted entirely to the manufacture of aluminum tanks for aircraft, fuel, oil, hydraulic, filter and belly tanks. Other products were various aircraft parts, including fins, rudders and ailerons. Among the accessories were oil separators, both Army and Navy types, and relief tubes, venturies and brackets.

Metal and Tool Reconditioning Service, New York, developed practically a new industry to solve one of the most perplexing problems in the war plants, at the same time speeded up production and saved huge quantities of valuable tool steel. The company developed its Cleja process for reconditioning steel files, recovering from 75 to 90 per cent of the original efficiency for a third of the cost of a new file. The results were reduced file costs, increased production through use of sharp files, also three times the normal use. The Cleja process also was used to treat new files, giving them an overall efficiency of 175 per cent at 6,000 strokes.

Micro Switch Corporation, Freeport, Ill., manufacturer of compact, light weight, long lived, snap acting electric switches of the precision type more than doubled its research and manufacturing facilities in 1943. More than 2,400 types of switching units were produced for specialized use in airplanes, tanks, submarines, surface ships, fire control, radar equipment, safety devices, instruments, machine tools and many other vital applications. The new Peanut Micro Switch was smaller, and lighter than the standard Micro Switch. It offered a wide gap, high contact pressure, resistance to vibration, and negligible contact bounce which adapted it to use on difficult d-c loads. A heavy duty Micro Switch equipped with a magnetic blowout found wide use on highly inductive d-c loads on aircraft for high altitude performance. Many styles of brackets, actuators and housings were redesigned to accept the standard Type -R31 basic Micro Switch unit which was stocked at all Service Air Depots. This standardization greatly aided in reduction of the spares program, and facilitated service operations.

Monogram Manufacturing Company, Los Angeles, Calif., supplied precision-made sheet metal clamps or fasteners and applying tools to major aircraft manufacturers and subcontractors throughout the aeronautical industry. As manufacturers of 3H safety lock clamps and applying tools, Monogram increased output from 15,000 clamps to 85,000 daily. Monogram produced many different styles and types of safety clamps which were essential to riveting operations on aircraft. The original clamp was an open spring type, with the locking needles made from bright basic wire. However, through extensive research and experimenting, greater utility and higher safety factors were found through the use of a cold drawn, high carbon content tempered steel, swaged in punch presses for precision accuracy. The adoption of this improvement made the open spring type of clamp practically unbreakable, thereby insuring safety in its use. With safety a slogan, Monogram provided additional protection by developing its plunger seal and triple lock line of clamps. These clamps differed from the open spring type in that the exposed spring plunger of the plunger seal clamp was sealed to the body, preventing the clamp from flying apart in the event of breakage. The enclosed spring plunger in the triple lock clamp was sealed completely within the body with the same result. Other features of the clamps were ability to hold sheet metal securely when applied in oversized holes and the provision for additional spring pressure was required. The clamps were standard equipment. Monogram also developed a new model all purpose applying tool for all types and makes of clamps, so designed that it was physically impossible for a clamp to fly apart while being applied.

Moore-Eastwood & Company, Dayton, O., supplied the aircraft industry with tools, dies and special machinery, and produced bomb racks, bomb shackles, gun sights, gun mounting posts, gun

mount adapters, filler valves, gun synchronizer generators, pistol mountings, tab controls and cable meters for tow-targets.

National Screw and Manufacturing Company, Cleveland, O., was turning out fifteen million screws and nuts and bolts and rivets every day, and by means of various ingenious processes was saving time, money, manpower, critical materials and precious tools in the process. Making a bolt or a nut or a screw was not as simple a business as it appeared, not when the effective performance of war machines and the lives of men depended on its perfection. Each bolt or screw was an integral part of a plane or tank or gun; and its construction was a highly complicated precision operation followed by rigid inspection, including magnification 200 times by a thread form comparator, magnetic flaw tests by Magnaflux equipment, hardness control by a Rockwell testing machine and pitch diameter checks with roller snap gauges.

Time and materials were saved by new methods. For example, a carburetor bolt was originally made on screw machines. It was upset by the hot heading method. Two faults developed. The process was not satisfactory in forming the head to the required tolerance. The contractor could not secure the required quantity by screw machines. A cold heading method was developed by National. It consisted of forming a round head and milling the required hexagon shape. Thus the shank was smooth and free from imperfections which often resulted from the former method. The result was a stronger, better product, a 76 per cent saving in material and critical automatic screw machines released for other work.

Again, a special type of cowl fastener was needed in large quantities. This piece had been produced on a screw machine, milled from bar stock. It required six automatic screw machines for the quantity desired. The machines were not available. National engineered a plan for producing these fasteners on headers with secondary operations, using a special 4-spindle pointing and drilling machine. It saved 68 per cent of raw material and 50 per cent manpower. There was the dome nut for bullet-proof self sealing fuel tanks on combat planes, used for openings in the tanks where they had to be opened and sealed up again, and also for bomb bay doors. Plane manufacturers complained that they could not get dome nuts in sufficient quantity. The nut usually had been made from bar stock on automatic screw machines. National made it by upsetting stock of smaller diameter, obviating the need for a large number of automatic screw machines, which were not available anyway. The results were important savings in manpower and in materials which formerly had been milled off by the other method. Tolerances were very close on this nut, .003 of an inch, and it required very accurate work; yet with this newer method production reached 50,000 a day. A stainless steel gyroscope strut was causing trouble for a contractor. Only one of these struts could



THE HERMAN NELSON HEATER  
Used in warming engines in cold weather.

be produced every three minutes on an automatic screw machine. Bicycle spoke machines were converted, swaging stainless steel wire down to the proper diameter, then rolling the thread. The finished strut under the new method had greater tensile strength and rigidity, which was important. Moreover, it released about 30 automatic screw machines for other work, and the saving in man hours was 40 to one.

Herman Nelson Corporation, Moline, Ill., produced a self-powered, portable heater which was successfully used in a great variety of applications by the armed forces and commercial organizations. The heater was a completely self-contained hot air heating plant, mounted on wheels and weighing only 290 lbs. A push-propeller type fan forced the air around the finned combustion chamber and out through two 12-inch vents at a rate of 2,000 cubic feet per minute, with a heating capacity of 250,000 btu per hour. In operation, the heat was generated in the combustion chamber through a specially designed, gravity vaporizing burner using gasoline as fuel. The fan was driven by a small gasoline engine or electric motor. An ingenious duct system conveyed heat from the unit to its point of application. Provided with the heater were two 12-inch waterproof, heat and flame resisting, collapsible canvas ducts, each 24 feet long. On some models, six half-foot diameter ducts 14 feet long, were supplied as either additional or alternate equipment. A combination of the two type ducts gave six high-pressure outlets at a distance of 38 feet from the heater. One of the most extensively used applications of the Herman Nelson Self-Powered Heater was the pre-heating of truck, tank and airplane engines during cold weather or in extreme climates. Other important uses have been the heating of tank cars to obtain a faster

flow of congealed oil, the heating of aircraft hangars, huts and storage spaces and the thawing of exposed equipment.

Norma-Hoffmann Bearings Corporation, Stamford, Conn., went ahead with augmented production of its lines of precision ball, roller and thrust bearings, adapted for practically every load, speed and duty. In the aviation division, new styles of sealed aircraft control ball bearings, designed to meet special requirements for control applications, were developed and marketed. The company's line included single and double-row, shielded and unshielded, as well as enclosed felt seal bearings with removable seals.

Northern Aircraft Products Division of The Aviation Corporation, Toledo, O., used only women on basic production of valve seats, guides and other precision parts for aircraft engines and propellers. Men were employed in supervisory, training and job-setting.

Numberall Stamp & Tool Company, Inc., Huguenot Park, Staten Island, N. Y., expanded facilities for its output of numbering machines and marking devices especially adapted for use by manufacturers of aircraft and engines. These machines were utilized in numerous industries to mark machine parts, gears, airplane parts and sheet metal, and to stamp details into name plates.

The Onsrud Machine Works, Inc., reorganized and expanded its design and production facilities for its high speed nonferrous metal working machine tools and accessory equipment. Production of cutters had become an important manufacturing problem and was solved by establishing a new and complete plant for this work only. New plant space and personnel were obtained and departmentalized also for the



ONSRUD BEVEL MILLER A-92

It housed four cutter motors, two on each end, which traveled on bridge arms and could be tilted to machine bevels on flat sheet aluminum alloy stock.



production of such aircraft machine tools as the A-80 automatic contour milling machines. Machines of this type, while made up of many basic standard parts, required considerable engineering and special work to provide a unit exactly fitted to an aircraft manufacturer's particular needs. One unusual A-80 machine delivered, permitted progressive work on a single bed. It had two traveling carriages, each housing four high speed milling heads. Work completed by the first carriage was immediately transferred to the second work station under the second carriage for finish operations.

New Onsrud machines, the first of their type, were designed, tested and delivered. The A-96 bevel miller was employed to bevel the edges of flat aluminum alloy skin sheets. Bevels were made up to 8 inches wide to surface tolerances of .0001 inch to permit a perfect lap of skin sheet sections. Machines were made to whatever length the work required, built of standard 15 ft. and 7½ ft. bed sections. In designing this type of machine, a fundamentally new mechanical device was developed and named the centrifugal bearing preloader. With this device all end play that might develop in the vertical cutter spindle was taken up automatically or adjusted. Thus true rotation of the end mill cutters in whatever horizontal plane selected was assured. Another type of bevel miller was the A-92, which housed four cutter motors, two on each end of the machine. The cutter motors traveled on bridge arms and could be tilted to machine bevels on flat sheet aluminum alloy stock. Each of the cutter spindle assemblies included a centrifugal bearing preloader. Bevels on many different types of contours were handled. The machines were delivered to the two prime contractors of the B-24 Liberator to perform the skin sheet beveling necessitated by the lap construction of that type of aircraft. Tooling of different types was developed as technological advances and greater standardization of machining practices took place in the aircraft industry; for example, the unit fixtures designed and built for the A-80 automatic contour milling machines. The fixture, consisting of a cast and machined frame, fitted directly on the table of the machine. The work template and rest blocks for positioning the work were an integral part of the fixture unit, and pneumatic cylinders and clamps for holding the work were assembled to it. All parts such as template and rest blocks remained in perfect alignment, handling and storage were simplified and set-ups on the machine were made quickly.

Pacific Aviation, Hollywood, Calif., with another division operating a new plant in Los Angeles, was in peak production on hydraulic control valves, selector relief valves, triple selector valves, four way gas valves, fuel shut-off valves, landing gear actuating cylinders, wing flap actuating cylinders, engine cowl flap actuating cylinders, landing gear link control cylinders, bomb door operating cylinders, bomb release gears, main landing gear struts and die flap booster cylinders. The new plant in Los Angeles was equipped to process raw materials

into completed units. In order to make the plant self-contained, the following facilities were added—heat treating, plating, magnaflux, painting, buffing and sandblasting. The critical shortage of gauges was overcome by the installation of facilities which enabled the Company to manufacture its own gauges.

The Palnut Company, Irvington, N. J., developed a new starter wrench for use in assembling locknuts and self-locking nuts in hard-to-reach spots on aircraft engines and other airplane parts.

Permoflux Corporation, Chicago, Ill., developed a dynamic headphone for airplane radio to meet requirements which included shutting out the terrific noise during battle and maintenance of fidelity and sensitivity under reduced air pressures up to 40,000 feet. The new dynamic headphone incorporated the moving coil permanent dynamic principle. It was hermetically sealed against moisture and dust, at the same time maintaining desired frequency response characteristics throughout all altitudes. Performance was not disturbed after submersion in salt water. It also had a special magnetic shield to eliminate interference with compass and other sensitive equipment.

Pesco Products Company, Cleveland, O., developed improved fuel pumps and hydraulic pumps to meet conditions encountered in extreme cold and high altitudes. A new altitude chamber was added to the laboratory.

Pioneer Parachute Company, Manchester, Conn., developed its pioneer P3-13, weighing 18 lbs., and a lighter, thinner and more compact chute than former models. It was accepted as standard equipment by the Army and Navy. Pioneer also developed a new parachute harness permitting easier and quicker adjustment, also a new pilot chute designed to provide instant and positive action in accelerating the opening of the main canopy. In co-operation with Cheney Brothers, Pioneer developed a new nylon feather weight fabric which it claimed to be lighter, thinner and stronger than silk. Pioneer also improved its test tower to test parachutes. A new canopy tester permitted visual observation at close range of the reactions of a parachute canopy under shock loads up to 18,190 lbs., while another phase of the testing technique permitted inspection of canopy design, pattern, construction and dimensions under 20 lbs. of radial pressure on each suspension line.

Porter-Cable Machine Company, Syracuse, N. Y., developed a new precision tool, the wet-belt surfacer, to replace or supplement operations on millers, surface grinders, planers and shapers. The new surfacer was designed to finish castings at right-angles, true-flat and glass smooth with only one application of each face to the belt and without mounting the piece in a fixture.

Remington Rand, through its Systems Division, Buffalo, N. Y., supplied the industry with its Kardex method of visible record control, featuring its exclusive Graph-A-Matic signaling system, which was

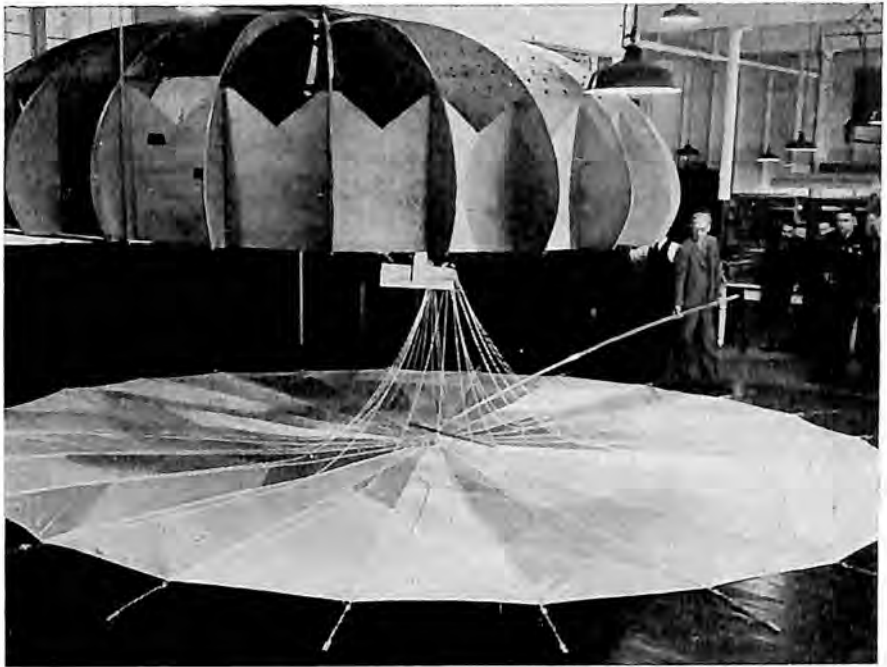

#### PIONEER PARACHUTE TEST

This illustrates the spread test, a method that permits study of canopy construction, design and measurements at close range.

designed to provide instant information needed for effective control of production, personnel administration, materials and machine load.

Republic Aircraft Products Division of The Aviation Corporation, Detroit, Mich., expanded their production of hardened and ground high precision parts for aircraft engines and propellers in two plants. The greatest volume of more than 200 items manufactured were valve tappets, tappet guides and rollers, valve seats and locks, silver plated knuckle pin locking plates, counterweight pins, thrust bearing nuts and propeller cones.

The Reynolds Metals Company, Aircraft Parts Division, Louisville, Ky., was part of a system of 38 plants strategically located throughout the country, with over 20,000 employees. The Company's Alabama aluminum reduction plant and rolling mills, a complete aluminum processing and fabricating unit, carried through all operations at a single location, starting from the domestic bauxite ore to finished aluminum alloy sheet, ready for aircraft construction.

The Roberts & Mander Stove Company, Hatboro, Pa., produced catapult cartridge tanks, parachute containers, firewall and cockpit doors for the Navy Vought-Corsair plane, and other sheet metal assemblies, and also heat treating of armor plate and tubing.

The Rochester Manufacturing Company, Rochester, N. Y.,

reached peak production on an aircraft pressure transmitter, a safety device to keep fuel and oil away from instrument panel and cockpit and reduce the hazard of broken lines, loss of fuel or oil and crippling of engines in combat. Other items which reached scheduled requirements were aircraft precision dial thermometers, one for cabin air temperature, the other used as a free air temperature indicator.

The John A. Roebling's Sons Company, Trenton, N. J., combined the distribution of aircraft products with engineering and research supplied to the industry through its Aircord Division, formed in May, 1943. The company increased production of aircraft cord, strand, terminals and assemblies by placing in operation additional manufacturing facilities, while it continued to supply wire rope, wire rope fittings, aircraft slings of standard and special design, Lock-Clad control cord, electrical cables, round and flat wires, woven wire fabrics and specialties. The range of sizes and types of Roebling cable assemblies for aircraft slings and controls was materially broadened by installation of new swaging, measuring and proof-loading facilities at the main plant at Trenton, and the over-all productive capacity of these products was further enlarged by placing in operation a supplementary assembly plant at Los Angeles, Calif.

Rohr Aircraft Corporation, Chula Vista, Calif., supplied assembly line production of complete power plant installations and manufactured parts and assemblies to meet the sharply increased demand of prime aircraft contractors. Rohr, for the first time in the history of aircraft manufacture, produced entirely complete engine installations as a subcontractor and shipped them to prime contractors for installa-



ASSEMBLY LINE AT ROHR AIRCRAFT

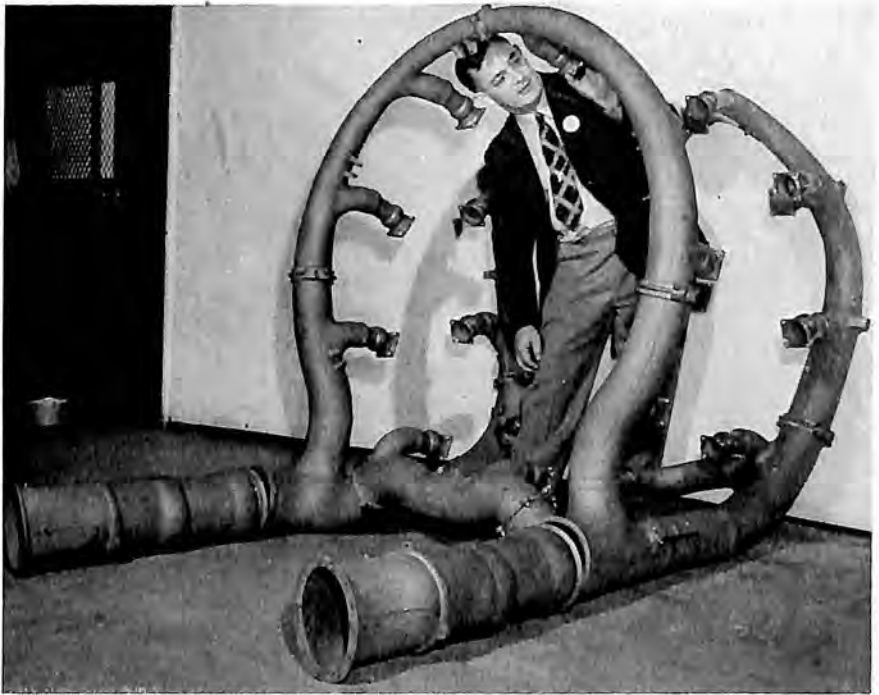

#### RYAN EXHAUST MANIFOLD

Built in huge quantities for important combat aircraft, Ryan manifolds of this type incorporated the ball and socket universal joint.

tion in an airplane. The power plant assembly was complete with cowling, motor assemblies and components. Its installation in the plane was accomplished in a few minutes instead of the usual few days. Production was carried forward to multiple assembly lines to supply the constantly increasing demand. The company also instituted conversion operations. In process of conversion from military to cargo ships were the Consolidated PB2Y3s. All war equipment was removed—nose, top and tail turrets, waist guns and armorplate. The original PB2Y3 power plant assemblies and oil tanks were replaced by four modified PB5 power plants of the same 1,200 h.p., without the supercharger. The interior of the military hull was completely engineered by Rohr and Consolidated engineers to meet Navy specifications for the conversion and modification.

SKF Industries, Inc., Philadelphia, Pa., was increasing steadily its production of aircraft bearings of all sizes and types for military and commercial aircraft. Balls and rollers were held to size within 25 millionths of an inch, while other dimensions of the rings were controlled by tolerances of ten thousandths of an inch. Rigid inspections and tests were maintained to assure this accuracy. Among the

aircraft types were cylindrical roller bearings used for the crankshaft main bearings in the principal radial engines and the grooved type ball bearings used for the propeller thrust location on virtually all engines. In addition, many bearings of both types were made for use on auxiliary parts and accessories, rocker arms, superchargers, generators and starters.

A. Schrader's Son, Division of Scovill Manufacturing Company, Inc., Brooklyn, N. Y., utilized its greatly expanded plant facilities for tire valves, tire valve replacement parts and tire pressure gauges. The firm also manufactured shock strut valves, a type fashioned on the same principle as the standard tire valve. It had a special high pressure valve core, which was replaceable, and a special high pressure cap. The sealing washer in this model was made of soft copper which formed an air-tight seal when the cap was applied to the valve and tightened with a wrench.

Scintilla Magneto Division of Bendix Aviation Corporation, Sidney, N. Y., supplied Bendix-Scintilla magnetos for all types of airplane engines, spark plugs, switches and radio shielding.

Scott Aviation Corporation, Lancaster, N. Y., expanded its aircraft accessories development facilities, doing basic research on many accessory needs for aircraft of all types. Among these were the development of shock struts for Army helicopters and special assemblies for experimental pursuit ships. A new oxygen equipment laboratory also was added, made necessary by the development program on high altitude oxygen equipment for fighters and bombers.

The Seybold Division of the Harris-Seybold-Potter Company,



MORRISON METAL STITCHING MACHINES

Developed by the Seybold Division of the Harris-Seybold-Potter Company.



Dayton, O., developed several models of its Morrison aircraft metal stitching machines which proved to be of the utmost value in saving time on fabrication of parts made of aluminum, stainless steel, plastics, cork, rubber, asbestos, wood or canvas. The stitches eliminated drilling of holes and saved up to 90 per cent of time formerly required for certain subassemblies.

The Sheffield Corporation, Dayton, O., developed an internal-external measuring instrument with a capacity of 12 inches, a ball checking and sorting machine for checking bearings up to 11/16 inch diameter at the average rate of 25,000 per hour, and an automatic roller bearing checking machine; also a micro-form grinder for producing form tools having various profiles, and a thread grinder with a multi-ribbed wheel for producing threaded sections in one quick operation by plunge cutting.

Shell Oil Co., Inc., New York, greatly increased its manufacture of aviation fuels and lubricants. Special high octane blending components were developed which enhanced the quality of aircraft fuels and increased the available quantities. Some of these components were made available to the petroleum industry as a whole. Development of new and improved fuels and lubricants, as well as increased production were on the company's 1943 program.

Shure Brothers, Chicago, Ill., developed new types of microphones and headphones used by combat air crews. The change from aluminum to bakelite in a hand-held set made for the Signal Corps resulted in a saving of 73,000 pounds of aluminum in 1943. Another development was an oxygen mask microphone for high altitude flying to function in varying atmospheric pressures due to altitude and the extremely low temperatures. An improved throat microphone also was developed which increased intelligibility under violent air battle conditions.

Simmonds Aerocessories, Inc., New York, with plants in Long Island City, California and Vermont, devoted expanded facilities to peak production of specialized aircraft and industrial equipment developed under Simmonds patents. The Simmonds-Hobson automatic engine control, Mark 40, had introduced Simmonds into the power control field in 1942. This was followed in 1943 by the Mark 46, an advance over the 40. In addition to automatically regulating the manifold pressure the new unit also provided automatic mixture control for aircraft engines.

The Simmonds chronometric radiosonde, used in obtaining high altitude weather data, differed from others. It used time measurement in securing and transmitting all data, and was developed further into an integrated chronometric radiosonde system including instrument and ground equipment. The Simmonds-Benton aircraft power plug, with its triple taper seal, interchangeable construction and other exclusive design features was a mica plug. Simmonds ceramic plugs

were introduced in 1943, having been developed to meet wartime needs, specifically for the most powerful military engines.

The Simmonds hydraulic accumulator was an airloaded pressure storage tank providing stored power for auxiliary purposes. The Simmonds hydraulic fuse saved the balance of the fluid that would ordinarily escape through a bullet-pierced or ruptured hydraulic system. The fuse itself was only five and one half inches in length and three ounces in weight. Fuse capacities ranged from 10 to 40 cu. in. A 40 cu. in. fuse would protect an actuating cylinder with displacement of 40 cu. in. or less and so on, according to size.

With more than 250,000 Simmonds push-pull controls installed on American and English military aircraft, their range of application was extended by the development of a fitting known as The Radian Unit, designed to convert push-pull or lineal motion into angular travel, thus permitting installations on propellor governors, carburetor air controls, supercharger controls and elsewhere.

Socony-Vacuum Oil Company, New York, contributed to the war program by production of essential high octane aviation fuel, as

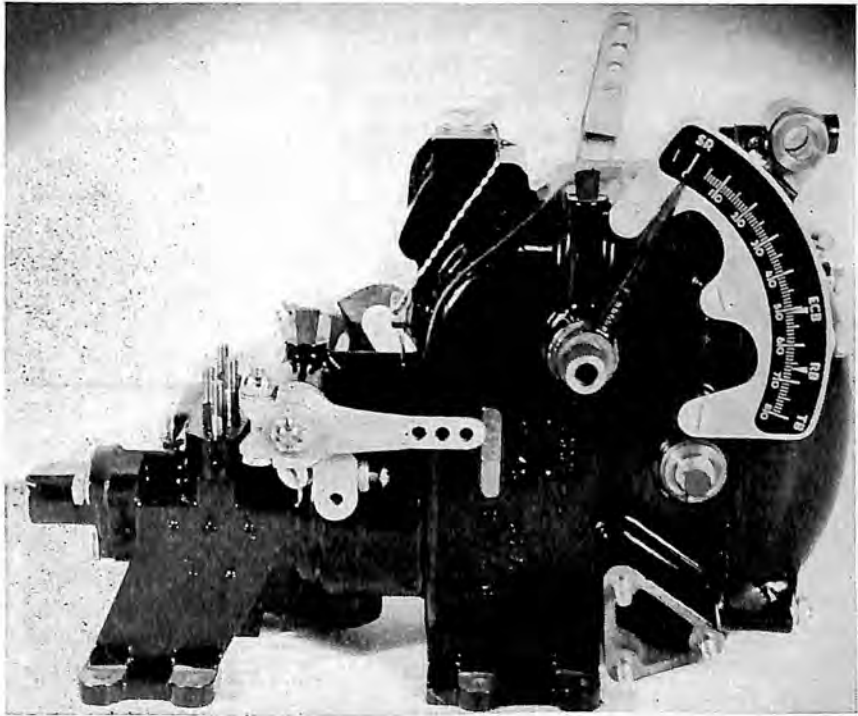

#### SIMMONDS-HOBSON AUTOMATIC ENGINE CONTROL

The new Simmonds-Hobson automatic engine control, Mark 46, with die cast body, installed on the planes of the United Nations and produced by Simmonds Aerocessories, Inc., the American manufacturers of this device.

well as motor gasoline for military use, which accounted for 41 per cent of its total gasoline manufacture. The 62,000 barrels a day which the company produced for war use was made possible by the conversion of much equipment which had been designed and constructed for commercial grade gasolines. A great advance was made when the thermofor catalytic cracking process, known as TCC, was put into operation in the fall of 1943. Construction of TCC plants was speeded, and each unit added substantially to the aviation grade fuels available to United Nations' air fleets. The entire construction program of 34 TCC cracking units was to be completed in June, 1944.

Not content with this advance in the methods of producing high octane gasoline, Socony-Vacuum's research and laboratory staff of over 700 devoted its efforts continually to new and better products in the aviation field, as well as in other directions. Among the new products for aircraft were an extreme pressure low-temperature grease, two extreme pressure low-temperature oils and a hydraulic fluid. The grease—Aero Mobilgrease E.P. Lo-Hi—was designed for heavily-loaded gear cases on aircraft and had operating characteristics embracing temperatures from 67 degrees below to 300 above zero. The low-temperature oils—Aerovac E.P. Gear Oil No. 1 and E.P. Gear Oil No. 2—were of two different viscosities for gears requiring or designed for oil lubrication. No. 1 was a high viscosity index oil with a pour point at 55 degrees below zero. The minus range of Number 2 was 30 degrees. The hydraulic fluid, Aero Mobilfluid HFA, was designed to meet a specification calling for a product operating at 75 degrees below zero. The Socony-Vacuum fluid surpassed this requirement and had a guaranteed pour point at 85 degrees. Many other products for specialized application were developed. In several instances the performance records provided by the research and operational study carried on by the company was the basis for Government specifications. Socony-Vacuum also produced for aviation use 15 special products such as compass fluids, instrument oils, gear oils and hydraulic fluids, as well as a large complement of aircraft greases and a complete line of lubricating oils and fuels to meet all Army and Navy requirements.

Another contribution of Socony-Vacuum was its share of the Neches Butane Products Company plant at Port Neches, Tex. It was the world's largest contributor of petroleum butadiene for the synthetic rubber program, and was designed to produce one-seventh of the nation's synthetic rubber needs. Socony-Vacuum, with four other major oil companies, contributed to the operation of that plant without management compensation.

Solar Aircraft Company, San Diego, Calif., designed and manufactured anti-monoxide exhaust systems and related aircraft parts such as cowl wells, mufflers and heat exchangers. A new product was Solar welding flux, No. 16GH, first developed in Solar laboratories

specifically for the specialized welding of stainless steel and similar alloys in Solar's own plants; and later used by many other war plants as an aid to faster production. Solar Welding Flux required no shellac and could be applied days before actual welding, sticking despite frequent handling on assembly lines. It facilitated mass production of stainless steel airplane parts. Another stimulus to efficient welding was its freedom from toxic fumes.

Southern California Airparts, division of Jarvis Manufacturing Company, Glendale, Calif., maintained a complete engineering and research staff for the development, fabrication, and production of aircraft tanks—hydraulic, fuel, oil and anti-icer. These standards were tested and put in production. Aluminum and steel fabricated and welded tanks were produced by the Division, which with expanded plant space, increased production of bomb racks, empennages, baggage doors, access doors, troop ship benches, wing tips, tanks of all kinds, main entrance doors, corrugations, supercharger mounts, map boxes and many other sheet metal subassemblies.

Speedway Manufacturing Company, Cicero, Ill., developed motors and gearmotors ranging in output from one three thousandth to one third of a horsepower, which were used on a variety of airborne electronic devices.

Spencer & Morris, Los Angeles, Calif., specialists in application of overhead materials handling equipment for ships and aircraft, contributed to the production speed of both, due to the organization's capacity to cope with problems as related to production layout. Among major achievements were the first mass production aircraft equipment installed at Consolidated Vultee's Downey, Calif. plant; with its overhead production line; similar equipment at Lockheed's two main Burbank plants, a completely revolutionary production line at Avion, Inc., Los Angeles plant; and such outstanding projects as the Gyro Float test stand which tested an airplane engine without rigid connection.

Sperry Gyroscope Company, Brooklyn, N. Y., developed its automatic gyropilot to a state of perfection where, linked to the mechanism of the bombsight, it took the place of the human pilot at the controls for 20 seconds before bombs were released in order to assure greater accuracy in American precision bombing attacks on enemy targets. The precision with which our bombers hurled explosives squarely into Berlin's war plants during the first daylight raids over that city in March, 1944, so puzzled the Germans that they credited it to a new secret weapon. They were partly right. It was secret, and some of it was new; although the Sperry aircraft gyropilot was in general use on big planes, both combat and transport, long before the outbreak of the war. It contributed much to crew and passenger comfort during long flights through rough and stormy weather. It provided steadier gun platforms for the defending gunners on our bombers, aided in

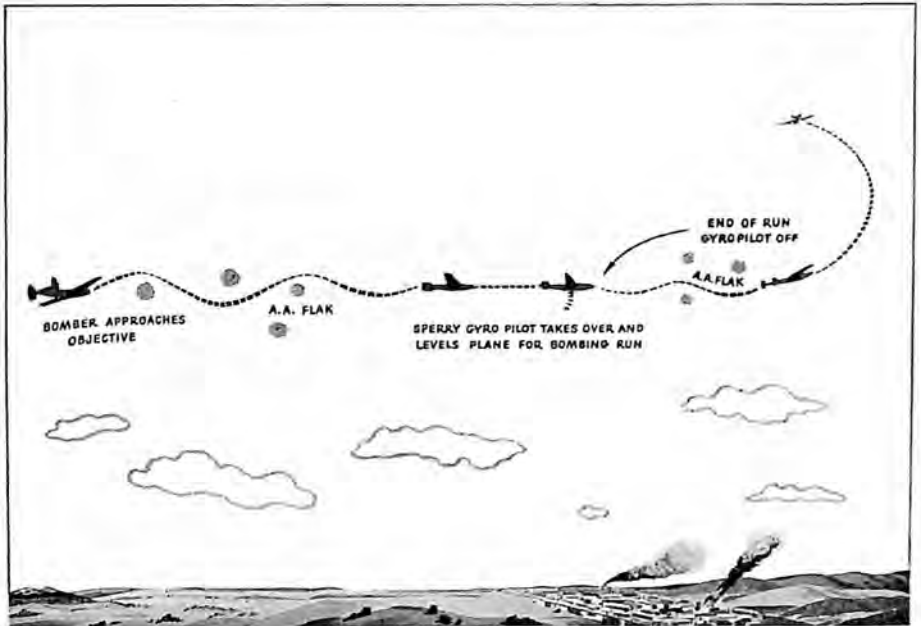

DIAGRAM OF AUTOMATIC BOMB RUN

For about 20 seconds before the bombardier released his bombs over the target, the pilot kept his hands off the controls and the Sperry automatic gyropilot controlled the plane and kept it on a straight course.

securing the precise navigation necessary to reach distant pin point objectives, such as industrial targets and military installations deep in enemy territory; and it was of vital necessity during the last 20 seconds of the actual bombing run.

The Sperry gyropilot was based on the principle of the spinning top which the genius of the late Elmer Sperry translated into many stabilizing instruments. Lawrence Sperry, aviation pioneer and an inventor in his own right, used the gyroscope automatic control in his airplane as far back as 1914, showing how it could be kept on a true course without the pilot touching the controls. The gyroscope was a scientific top that obeyed the laws of rigidity and precession. Set it spinning, and as long as the number of revolutions remained constant, the axis of rotation would tend to remain fixed in the same position in relation to space. That was gyroscopic rigidity. When the spinning gyroscope was pushed in a given direction, it would not move at the point at which pressure was applied, nor would it move in the direction of that pressure. But it would move 90 degrees beyond the point of applied pressure and in the direction of the gyroscope wheel's rotation. This contrary behavior was known as gyroscopic precession.

The gyropilot mechanism linked those two characteristic properties of the gyroscope to a nervous system of amplified electrical impulses.

The spinning, therefore rigid, gyroscope provided a fixed point of reference around which the plane itself moved. The gyroscope set in the correct position to maintain a desired course for the plane, and then connected with the electrical apparatus that picked up, amplified, and instantaneously and automatically rectified even the most minute deviation from the course, provided the fundamentals of the automatic gyropilot.

The latest Sperry gyropilot employed two gyroscopes, each with a rotor weighing 32 ounces. When in operation, both were kept spinning at 24,000 r.p.m. by electronically controlled mechanisms. That gave greater stability to the point of reference and therefore more accuracy than ever before. One of the two gyroscopes was positioned on a vertical axis that tended constantly to point toward the center of the earth, and through connections with the elevator and ailerons, controlled the roll and pitch of the plane. The second gyroscope was positioned so that its axis tended constantly to point toward the horizon, and through connections with the rudder it controlled the yawing motion of the plane. So sensitive was the electronic pickup system that it could keep within less than one degree of the desired course on all three flight axes at the same time. Moreover, it not only would sense how far off the course the plane had been going, it also would tell how fast the plane was being taken off course, and also how fast the rate of movement was changing. The gyropilot then would take all those rates of change into account and then swing the controls to counteract all off-course motion so swiftly that the plane was snapped back on the true course instantly; so quickly that from a practical viewpoint it had not swerved at all.

With the sensitive gyropilot capable of maintaining absolutely true course control, which human beings could not do, the next step in precision bombing was to link the gyropilot with the bombsight. The bombardier, who took over the plane's operation before it went into the bomb run, sighted his target. The critical instant arrived. The signal went out. The pilot took his hands off the controls. The automatic gyropilot took over. For the next 20 crucial seconds, the gyropilot alone held the plane on the exact course it must fly if, according to the sighting by the bombardier, the bombs were to plunge into the target miles below.

Sperry Gyroscope Company's technical development in aircraft instruments could not be disclosed in detail. It was largely concerned with new types of all-electric aircraft instruments and gyropilots. The electrically driven instruments used whatever power supply was available, and were intended to be definitely superior to air driven instruments under all operating conditions. Electric drive was applied to the Sperry gyro-horizon and directional gyro indicators, as well as the gyropilot. A new development was the Sperry-M.I.T. detonation detector-equipment worked out in collaboration with the Massachu-



setts Institute of Technology, in cooperation with the Bureau of Aeronautics of the Navy, National Advisory Committee for Aeronautics and Wright Aeronautical Corporation.

The detonation detector made it possible for a pilot to regulate the fuel mixture to a point where the most efficient operation was obtained without danger to the engine from mechanical stresses set up by high pressures and high temperatures associated with detonation (change of rate in fuel combustion). In an ordinary automobile engine, detonation conditions could be detected by the usual knock, but in an aircraft engine, because of the high noise level, this was not always possible. Early experiments in detonation detection involved an actual measurement of the pressure in the combustion chamber of an aircraft engine, but later investigation showed that detonation could be detected by observing changes in the frequency of the mechanical vibrations transmitted through the cylinder wall. A pickup unit similar to a magnetic telephone receiver was attached to the cylinder wall and connected through an amplifier with a neon light indicator on the instrument board, which flashed a warning when detonation conditions occurred.

Control of detonation not only contributed to lowered engine maintenance costs and repair time, but also guarded against engine failure in flight and permitted attainment of the highest safe level of fuel economy. With the wartime stress on very long flights, both in air combat and in transport flying, fuel economy was extremely important. Auxiliary gas tanks which could be dropped when empty helped, but it still was essential that the engine itself be adjusted to attain the greatest possible economy in fuel consumption. Detonation detector equipment could be installed in virtually any type of aircraft or on aircraft engine test stands. It was compact and required little power supply.

Sperry Products, Inc., Hoboken, N. J., produced an exactor hydraulic control which was a simple one pipe hydraulic control system reproducing identical motion without backlash or time lag. It made possible the application of force from a remote station to move or position accurately devices such as carburetors, valves and governors.

Spriesch Tool and Manufacturing Company, Inc., Buffalo, N. Y., was in production on automatic bomb releases and shackles; and at the same time was specializing in helping other manufacturers reduce the number of parts in assemblies and effect other production speed-up changes.

Standard Aircraft Products, Dayton, O., was at peak production on aircraft lighting equipment, control valves and precision instruments for all types of planes. Standard's FAZ pressure control valve maintained positive pressure in aircraft fuel systems under all flight conditions. Its mechanism included a safety release in case excessive pressure was generated in the fuel tank. It also compensated for

vacuum release. At ground level the valve permitted free venting, and at altitude the valve closed. As the plane gained or lost altitude, the valve automatically increased or decreased restriction in the vent line, thereby maintaining proper working pressure. Standard's moisture-proof aircraft lighting fixtures formed another successful development.

Standard Oil Company of California, San Francisco, continued to stress maximum production of high octane aviation gasoline for the armed forces, air lines and aircraft plants. One large refinery was devoted solely to aviation gasoline, as well as a large portion of the facilities of two other refineries. A toluene plant was completed and put in operation. Standard also increased production of servo liquids for aircraft hydraulic auxiliaries, and expanded research in all phases of operations, with emphasis on air force operations in Arctic regions. This resulted in development of an efficient cold weather starting fluid for use in internal combustion engines.

Summerill Tubing Co., Bridgeport, Pa., developed a record number of new designs of tubing, and more than half of its full capacity peak production was for aircraft. Facilities were expanded to supply greater quantities of aircraft tapered and formed tubes; and a special department was established to assist in engineering, designing and managing production of many special finished and semi-finished parts. The Summerill handbook, *Aircraft Tubing Data*, first published in 1941, was revised and kept up to date. New warplane tubing included rounds, streamlines, squares and ovals. Special shapes and tapered tubes for structural parts were produced for airframes, engine mounts, landing gears and control parts. The tubing sizes ranged from tubing for hypodermic needles to special heavy wall tubes for fuel injection and hydraulic controls to withstand pressures up to 150,000 lbs.

The Superior Tube Company, Norristown, Pa., continued production in large quantities of finished aircraft engine push rods produced out of selected alloy steel. This increased production was made possible by a new department for the exclusive manufacture of these rods. Production of tubing for aircraft instruments, aircraft spark plugs, oil lines, hydraulic lines, and airframe tubing was also continued on a scale very much above any previous year. An outstanding contribution to the war effort was the further development of substitutes for seamless tubing, the principal type being the Weldrawn, a trademarked product.

The Surface Combustion Division of General Properties, Inc., Toledo, O., producers of gas fired heat treating equipment developed radiant tube firing, a method widely used by producers of metals and insuring close temperature controls over any predetermined range with precise atmospheric control. Great strides were made in the processing of glass for special shape dials, and as a result wider applications were introduced. Along with heat treatment of glass and metals the S.C. Engineers developed an eminently successful

combustion type heater for cockpit heating, gunbreach heating and wing de-icing. The heater was produced in a wide range of sizes. Successful tests were completed in both aircraft and pressure chambers, with perfect performance in aircraft at 33,000 feet altitude.

Switlik Parachute Company, Trenton, N. J., was at peak production on seven different types of parachutes for the air forces, besides supplying parts so that riggers could keep the chutes in repair during operations in all theaters.

The Switlik safety chute had many decided advantages, including simplicity of operation, low costs of maintenance, compactness, light weight, quick and positive opening and low rate of descent. It was designed to withstand a drop test load of 800 pounds. All materials used in its construction exceeded the requirements established for parachutes by the Government.

The nylon used in the canopy was especially woven for parachutes, having a high tensile and tear strength. Suspension lines were made of pure silk, having an outer casing and an inner core, which provided a soft, kinkless cord with a tensile strength in excess of 450 pounds. The harness webbing was made of pure purged linen, and had a tensile strength exceeding 3,000 pounds, yet it was soft and pliable. All forged hardware was of chrome nickel steel, heavily plated with cadmium. The cotton duck used was of high strength and was water repellent.

Realizing years before the start of the present conflict, that this country should not be entirely dependent upon Japan for parachute silk, Stanley Switlik immediately started collaborating with silk processors in the country, impressing upon them the necessity for a substitute for silk in parachutes. He was highly instrumental in having those processors produce nylon fabric, of a texture and weave that was highly efficient and comparable to all tests formerly attained by natural silk, with the result that all parachutes were being made of nylon fabric in 1944.

Forseeing, too, the necessity for training parachute troops as far back as 1934, Mr. Switlik experimented with and built the first jumping tower in the yard of his home. Such towers later were used for training paratroopers.

Taylor-Winfield Corporation, Warren, O., continued its research and development in the field of aluminum welding, and introduced a complete new line of Hi-Wave capacitor discharge stored energy welders. The new Hi-Wave welders featured a dual pressure bellows airlock for improved aluminum welding. In the new models operating controls were located in a compartment on the welder proper convenient to the operator. A considerable number of Hi-Wave stored energy roll spot welders, wherein the spots were made between the periphery of two welding wheels, established enviable production records at speeds up to 300 spots a minute. The Taylor-Winfield

Corporation also introduced a complete line of hydraulic operated precision flash-butt welders, designed in a wide range of sizes. They proved particularly practical for welding tubing to forgings for struts and braces and other similar work, and were satisfactory for welding either cold rolled steel or alloys. A welder especially adapted for upsetting work also was introduced. Plans were made for several other new machines. Special resistance welders were designed and built for welding operations on war products such as shells, cartridge cases, bombs, mines and flares.

The Texas Company, New York, devoted most of its research and production facilities to the war effort. Most of the 100 octane aviation gasoline used by the Allied air forces was made by the alkylation process, and Texaco played an important part in its development. Additional methods of making aviation gasoline, including catalytic cracking, were used to meet the tremendous demands of war. New types of fuels were continually being developed for future engines. The Navy was supplied with lubricating oil and especially aircraft engine oils by the Texas Company, as were many domestic air lines. Large amounts of these oils were also furnished to the fighting fronts and to training schools here at home. The most significant development in aircraft greases was Texaco Low-Temp grease 100, for operation at temperatures down to 100 degrees below zero. Control bearings, actuating mechanisms and countless other parts on military aircraft exposed to extremely low temperatures formerly would not operate under such conditions. This problem was solved by a series of low temperature greases of which Low-Temp grease 100 was outstanding. Those products also were developed for use in other air force equipment such as cameras and bombsights. There was a Texaco grease available or under development for every part and accessory on Army, Navy or commercial aircraft. A special hydraulic oil operating at extremely low temperatures was made available to builders of military aircraft.

The Thompson Grinder Company, Springfield, O., was in production on hydraulic surface grinders capable of maintaining present day production schedules without sacrificing precision. Many noteworthy improvements were made on the standard line of machines, such as improved spindle construction, automatic down feed with spark out control which permitted one operator to produce repetitive parts from more than one machine at a time. A special machine was developed to grind channel sections in master rods and articulated rods, removing the tool marks produced by the previous milling operations, thus reducing the time required for polishing to an absolute minimum. The travel of the grinding wheel head was confined in such a way that it was only necessary to gauge the rod at one point and the entire shape was to the desired dimension well within the required tolerances.

Thompson Products, Inc., Cleveland, O., the company's west coast

plant in Bell, Calif., and its Defense Plant Corporation subsidiary in Euclid, O., were awarded the Army-Navy "E" in 1943 for the production of over a thousand different aviation parts and accessories. A considerable portion of this output was sodium-cooled aircraft engine valves. The company's aircraft accessories division greatly expanded deliveries of engine fuel pumps, fuel booster pumps, fuel selector cocks, and a quick-disconnect coupling that was installed on fuel, cooling fluid, oil and hydraulic lines. This coupling speeded up and simplified the servicing of aircraft in the field. Among the newer developments of the company was an improved oil filter scheduled for large-scale production.

W. Harris Thurston, Inc., New York, manufactured a complete line of aircraft tapes and fabrics including balloon and glider fabrics, utility cloths, lightweight cloths and other cloths to Army and Navy specifications.

Tinnerman Products, Inc., Cleveland, O., expanded its line of speed nuts and speed clips until it embraced over 1,500 shapes and sizes. New developments for aircraft assembly included new designs of the flat type, new tubular speed clips, cable clips, a full line of anchor type speed nuts, angle bracket speed nuts, conduit clamps, harness clamps, pulley brackets, junction box clips and special speed nuts and speed clips for plywood and plexiglas assemblies. Most important features of the new Tinnerman developments were big weight savings and marked reductions in assembly time. In some cases these savings ran as high as 80 per cent.

Titeflex, Inc., Newark, N. J., continued to manufacture a complete line of radio, ignition, and power shielding equipment and accessories for the aircraft industry. In addition to its principal product in this field, the Titeflex radio shielded ignition harness, the company also produced radio shielded spark plug elbows, shielding conduit and fittings, filter units, wiring manifolds, and terminal and junction boxes. Titeflex also supplied its well known pressure tubing for fuel and oil lines, instrument lines, and hydraulically controlled devices. Titeflex developed for the aircraft industry the Titeflex Unimold spark plug lead, an ignition lead which combined the feature of detachability and integrally molded construction. Another development was Titeflex Aerocon conduit, an improved type of ignition shielding conduit. Titeflex radio shielded ignition harnesses were standard equipment on war planes.

The Tomkins-Johnson Company, Jackson, Mich., produced its T-J Rivitor—an automatic air powered riveting machine to speed up this highly essential operation in mass production of aircraft which required rivets by the tens of thousands in every combat plane. The T-J Rivitor was in widespread use because its automatic feed and setting mechanism speeded up flush riveting. Pressure for riveting was supplied by a cylinder of compressed air, applied and stepped

up through a toggle mechanism. It was designed to handle exclusively aircraft requirements for aluminum alloy riveting, with capacity for rivets  $\frac{1}{4}$ " diameter by  $\frac{3}{4}$ " long. The machine was operated by a foot pedal. The rate of setting was limited only by the ability of the operator to move the work from hole to hole. There was no manual rivet handling. The machine was equipped with adjustable setting tools, so that common variations in the thickness of the materials being riveted were taken care of automatically. Major variations were taken care of through manual adjustments provided. The T-J Rivitor permitted precision setting at any height of vertical adjustment. The upper and lower toolings were accurately aligned so that vertical adjustment of the lower tooling could be accomplished without disturbing this alignment. In addition to flush riveting with counter sunk head rivets, the machine could be adapted to handle round head, full and semi-brazier head rivets by using a different type of rivet set

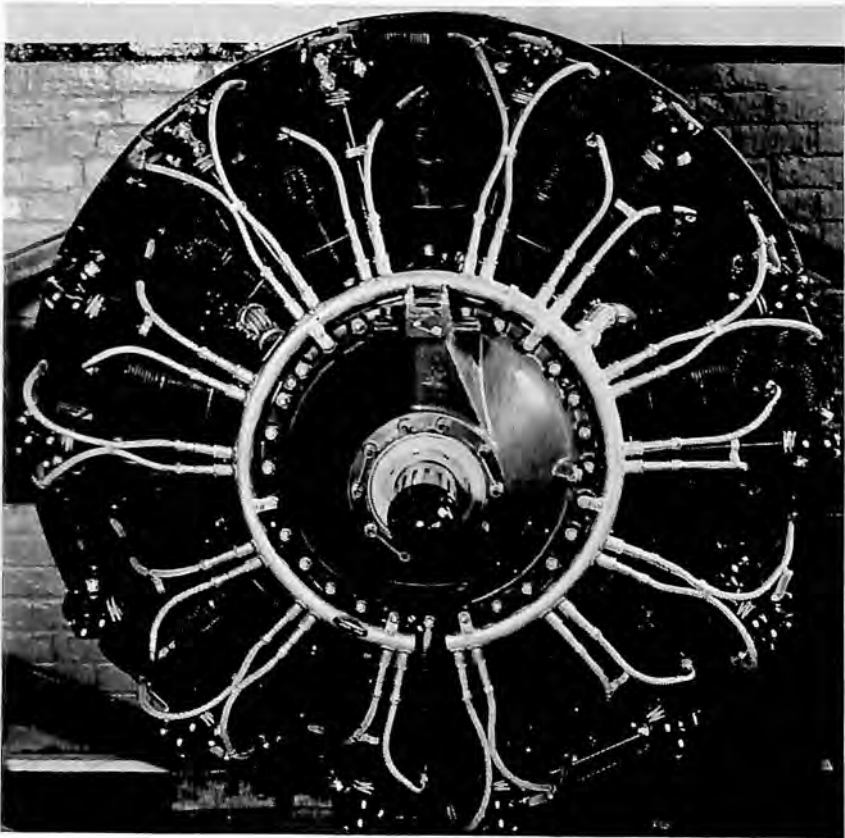

TITFLEX IGNITION HARNESS

Titeflex radio shielded ignition harness on a radial aircraft engine.



and rivet jaw construction. It was available in throat depths ranging from 9" to 36".

Tube Turns, Inc., Louisville, Ky., manufactured forged steel cylinder barrels, forged aluminum pistons, steel landing gear pistons, and numerous forgings for liquid cooled engines. The 9-inch up-setters, largest ever made, reduced spoilage of barrels and allowed all forging impressions to be encased in the machine. This permitted full use of the upsetter's great rigidity without spreading or opening of dies. The result was a forging of unusually close grain structure and desired physical properties. Another Tube Turns development was an improved method of forging aircraft pistons on the mechanical press as well as on upsetters. Because of its pioneering experience in difficult forging processes, Tube Turns was one of the companies selected to set up special plants for making forged aluminum cylinder heads for aircooled engines. Taking over the State Fair Ground buildings the Tube Turns engineers planned and equipped a complete plant for using a forging technique of their own development, and were ready for production of heads within six months. Included was a casting plant for alloying and cogging the forging stock. The use of 8- and 9-inch upsetters in producing forged aluminum cylinder heads under the process developed by Tube Turns enabled the company to maintain high standards of uniformity on this large and difficult forging. Newest of the Tube Turns forgings was an aluminum fin section to slip over the steel cylinder barrels of aircooled engines.

Union Aircraft Products Corporation, New York, manufactured junction boxes and conduit fittings, particularly ferrules, collars, couplings, elbows, nuts and adapters, and also expanded its line, resulting in the introduction of its products into the radio field. It introduced Uniprime finish in junction boxes; a unique process removing all high gloss spots imparted to the metal in the process of drawing, and leaving it with a uniform semi-glossy surface, attractive both inside and outside the junction box. It had no chemical action on either electrical equipment or applied paint, and as manufacturers could use a single coating of paint, it represented a substantial saving in money, labor and time.

United Aircraft Products, Inc., Dayton, O., produced an increasing number of their diffusion oil coolers noted for non-congealing, maximum cooling and quick warm-up qualities. They also developed a jacketless oil cooler saving weight and space and having inherent surge protection. An improved oil dilution solenoid valve, consisting of a resilient composition seal on the valve face which assured a perfect seal at all times, became standard Air Forces equipment. The company also produced oil temperature regulators, fuel pumps and units, oil dilution solenoids, fuel strainers, Y drain valves, fuel cocks, dial and handles and miscellaneous other parts for aircraft and combat vehicle fuel and oil systems, also hydraulic landing gear struts, tail

shocks, accumulators, hydraulic control valves and complete hydraulic equipment.

United-Carr Fastener Corporation, Cambridge, Mass., makers of the "DOT" line of metal fasteners, devoted a large part of its production facilities to making fastening devices and stampings for the aircraft industry. Airloc fasteners, used on aircraft cowling, hand holes, access doors, and other places involving similar problems, were notably improved. The scope of the line was extended to include a complete range of standard sizes and fasteners for special applications. The Airloc fastener was adapted for use on plywood. Embodying all of the principles of the tested and proven Airloc fastener for metal, it played an important part in plywood aircraft construction.

United States Plywood Corporation, New York, supplied its plywood products which were used extensively in the aircraft and marine fields, with large quantities also going into products for the Services. Flat waterproof weldwood plywood was in strong demand but metal-covered plywood, such as used for the Army's smokeless powder box, molded plywood, used for 18-foot auxiliary pontoon boats and for airplane parts, were likewise supplied in large quantities. Molded tubular weldwood, for Signal Corps masts, was manufactured in steadily increasing amounts and reached the record figure of six



UNITED-CARR FASTENER WIRE HARNESS CLIP

miles of tubing a week. Low pressure molding of plastic parts for use on aircraft was started on a large scale. The engineering and research laboratories of the corporation were active in the field of low pressure plastic moulding, and several interesting war products were developed.

Utica Drop Forge & Tool Corporation, Utica, N. Y., developed and manufactured a complete line of pliers and adjustable wrenches for use in aircraft manufacturing.

Victor Metal Products Corporation, Brooklyn, N. Y., developed an aircraft defroster fabricated from cellulose acetate butyrate and molded to shape as a substitute for aluminum, which resulted in a saving of two-thirds of the weight and 60 per cent of the cost. Another development was ammunition rollers, with tremendous savings in manhours and costs over former aluminum die castings.

Vinco Corporation, Detroit, Mich., developed and produced in increasingly large quantities fixed limit gages for precision work with tolerances as small as a millionth of an inch. One of the important Vinco developments was equipment to check the exactness of the involute curve or profile, in order to obtain closer tolerances. Other Vinco checking devices included wheel dressers for dressing abrasive grinding wheels to shapes ranging from the simplest to the most intricate; gear rolling fixtures for checking the pitch diameter eccentricity and backlash of part gears; indexing fixtures to index a part in a grinder so that any number of teeth could be ground and spaced accurately.

Waldes Koh-I-Noor, Inc., Long Island City, New York, developed the Waldes Truarc retaining ring, NAS-50 internal and NAS-51 external rings, as retainers in place of shoulders, nuts and threaded collars, to position bearings, bushings, shafts and pins, to take high axial loads in place of shoulders, and to save weight, assembly time and machining costs. The ring was made of high grade spring steel and heat-treated to about Rockwell C 50. It was tempered from its middle section to its free ends, and was provided with apertured lugs or ears at its free ends to facilitate handling in assemblies and disassemblies with special pliers.

The Weatherhead Company, Cleveland, O., was in peak production on aircraft tube and pipe fittings, drain and shutoff cocks, and flexible hose assemblies. Expansion of facilities kept pace with the expanding Air Forces program, and the Cleveland, and Columbia City, Ind., plants were devoting about 50 per cent of their facilities to manufacture of fittings and hydraulic cylinders for actuating bomb bay doors, wing flaps and retracting landing gear. The Glendale, Calif., plant was entirely occupied with development and manufacture of fittings and special hydraulic equipment for aircraft. The plant at St. Thomas, Ont., maintained its position as the largest supplier of fittings and hose assemblies to the Dominion's aircraft industries. Weatherhead engineers were active in research for the Air Forces

winterization program, in development of specialized valves and swivel joints to replace hose assemblies on high pressure systems.

A new hose end-fitting, known as the Q-A (quick-attachable) fitting, was perfected and introduced for use on medium pressure and medium-high pressure AN-H-6A hose lines. It could be assembled or disassembled easily from hose installations without special tools. By virtue of its expanded collet construction, it could be re-used. It also could be tightened further after original installation, a feature found extremely useful in combating cold-flow leakage in 65 degrees synthetic hose material.

Weber Showcase & Fixture Company, Los Angeles, Calif., converted its facilities for metal, wood and glass manufacturing to meet the varied production demands of aircraft manufacturers. Many special pieces of equipment were developed to meet the aviation industry's unusual construction needs. One outstanding contribution to increased output for outside production was "Old Ironsides"—the world's largest hydraulic press. This 1,100 ton modern giant accomplished wonders in speeding production on die-stamp auxiliary tanks and leading edge wing assemblies as well as other unusual pieces of equipment. Another Weber time saving device was the profiler planner. With that machine, jobs that formerly required six hours of hand planning are completed by six simple mechanical operations in 40 minutes. When the huge new P-38 expansion program was planned, officials of Lockheed Aircraft Corporation and officers of the Army Air Forces made a thorough study of subcontracting facilities and then chose the Weber company to fabricate leading edge wing assemblies.

The Wellman Bronze and Aluminum Company, Cleveland, O., operated at full capacity two large plants devoted to the production of castings. In the older plant were produced castings of heat-treated aluminum, bronze and brass alloys and numerous types of bronzes. In the newer plant operations were confined to patterns and magnesium castings. Among the firm's products were cast magnesium generator housings and aircraft landing wheels, cast aluminum pneumatic tool housing and Dowmetal pneumatic tool handles.

Western Electric Company, New York, reported that 27 per cent of its output was radio equipment for aircraft. The principal Western Electric aircraft devices were airborne radio command sets, microphones, headsets, ground transmitters, special navigational equipment, bombing devices, fire control devices, and other items on the secret list. The command set was light, compact, dependable under extremes of temperatures and able to withstand rough usage. The command set was a specialized radio telephone which permitted intercommunication between plane and plane, and plane and ground. Although command sets were originally in the medium frequency range, developments indicated multichannel high frequency apparatus. Western

Electric planned advanced models in 1944 to supersede the older types.

Headsets and microphones also were items of first importance in Western's war plants in 1943. The throat mike which, because of its quality of excluding extraneous noises while transmitting the speaker's voice sounds, found wide application not only in aircraft but in the tank forces and even in noisy areas in industrial plants, was continued in production, although recent Bell Laboratories developments promised to supersede it. One of these, an improved type of lip microphone, was accepted by the Navy and Marine Corps, and was in production.

Westinghouse Electric and Manufacturing Company, Pittsburgh, Pa., increased its output of aircraft accessories, such as aircraft generators, voltage regulators, relay switches, ammeters, voltmeters, voltammeters, lighting apparatus, Rectox engine starters, Micarta pulleys, molded and laminated Micarta parts, radio receivers and transmitters, and other equipment for planes and plane plants.

The S. S. White Dental Mfg. Company, Industrial Division, New York, produced an extensive line of flexible shafts for aircraft use. White engineers were cooperating with the industry in developing applications to power drive or remote control problems.

White-Rodgers Electric Company, St. Louis, Mo., manufacturers of temperature and pressure controls for heating, refrigeration and air conditioning, developed a line of automatic modulation equipment for control of engine cowl flaps, both air and liquid-cooled, oil cooler shutters or flaps, cabin temperature, both supercharged and normal, and carburetor air temperature. Equipment included Servo motors and motorized modulating temperature controls incorporating the White-Rodgers solid-liquid charged element which was designed to operate at temperatures from 90 degrees below to 600 degrees above zero without distortion of calibration or range due to changes in altitude or ambient temperature. Among other aircraft control developments, White-Rodgers perfected a differential pressure control for use in conjunction with motorized modulating control units operating oil cooler flaps or shutters. Plant personnel and facilities were expanded in 1943.

Wickes Brothers, Saginaw, Mich., extended their line to include a number of new types of machine tools for turning aircraft crankshafts and camshafts. These machines were engineered to combine more operations into one machine, thereby giving increased production per machine. Machines included single spindle multiple crankpin turning lathes for cheeking, turning and filleting all crankpins simultaneously on large aircraft and Diesel type multiple-throw crankshafts, contour turning equipment for turning the outside contour of all crankarms simultaneously on aircraft type crankshafts requiring complete machining and camshaft turning lathes for turning all cams simultaneously on camshafts. All machines for aircraft were made

heavier to handle increased production of large hardened alloy steel aircraft crankshafts. Crankshaft turning equipment included automatic center drive type lathes for high production machining of crankshaft main line bearings and automatic duplex type lathes for the turning of either intermediate main line bearings or crankpin bearings.

E. W. Wiggins Airways, Inc., Norwood, Mass., developed facilities for subcontracting work on military aircraft; and its enlarged plant was producing stressed skin assemblies, welded steel, aluminum and fabric assemblies and machined parts for Army aircraft, including troop transport gliders and helicopters.

The Wittek Manufacturing Company, Chicago, Ill., was in full-out war production on all types of hose clamps for planes and engines, the material being of non-critical mild carbon steel comparable to hose clamps of stainless steel construction. Wittek FBC and FBCA hose clamps were zinc plated for corrosion resistance. The company also manufactured a complete line of roll feeds and reel stands for punch press operations.

Wyman Gordon Company, Worcester, Mass., produced its line of laboratory controlled forgings for the aircraft industry.



#### WESTERN ELECTRIC ALTITUDE MICROPHONE

While battling the enemy miles above the earth, the pilot breathes in oxygen from this headgear and barks orders and information through a special Western Electric microphone concealed within the queer snout. Snug fitting earphones carried in the helmet enable him to hear. Thus his hands are freed for fighting.





# *ANOTHER BOOK*

*you will be  
proud to own*

## AMERICAN HEROES OF THE WAR IN THE AIR

VOLUME ONE

By

HOWARD MINGOS

THE HISTORY OF OUR FIRST 21 MONTHS OF AIR WAR

12 CHAPTERS, MORE THAN 1000 CITATIONS, OVER 400 INDIVIDUAL PORTRAITS, MORE THAN 150 ACTION PHOTOS AND MAPS—557 PAGES

**\$10<sup>00</sup>**

*Your own Bookseller or the Publishers*

LANCIAR PUBLISHERS, INC.

10 ROCKEFELLER PLAZA

NEW YORK 20 N. Y.

# Directory

SUBJECT	PAGE
Directory of Aircraft and Aircraft Engine Manufacturers . . . . .	400-420
Classified Directory of Equipment Manufacturers	424-500
Alphabetical Directory of Equipment Manufacturers	502-640
Aeronautical Chamber of Commerce of America, Inc. . . . .	642
Aeronautical Periodicals of the United States . . . . .	670
Air Transport Association of America . . . . .	642
Aircraft Owners and Pilots Association . . . . .	654
Aircraft War Production Council, Inc. . . . .	658-662
Aircraft War Production Council, East Coast, Inc.	664-668
Aviation Writers Association . . . . .	648
Civil Aeronautics Administration, U. S. Department of Commerce . . . . .	656
Congressional Committees Interested in Aviation . . . . .	672-676
Federal Communications Commission . . . . .	652
Institute of the Aeronautical Sciences . . . . .	646
Manufacturers Aircraft Association, Inc. . . . .	644
National Advisory Committee for Aeronautics . . . . .	652
National Aeronautic Association . . . . .	644
Post Office Department, Air Mail Service . . . . .	650
Society of Automotive Engineers, Inc. . . . .	646
U. S. Army Air Forces, War Department . . . . .	648
U. S. Department of Commerce, Weather Bureau . . . . .	654
U. S. Forest Service, Department of Agriculture . . . . .	656
U. S. Naval Aviation . . . . .	650

# Announcing



## AERO DIGEST BLUE BOOK

Accurate · Better

Compact · Different

Efficient · Factual

**A** complete, comprehensive, detailed Aeronautical Directory. It will completely cover the Industry in the United States, Canada and South America. It will tell you anything you want to know regarding WHO'S WHO and WHAT'S WHAT in aeronautics on this side of the Atlantic. It will be only 5" by 7½" in size, but it will be the World's biggest and best Aeronautical Directory.

**IT WILL CARRY NO ADVERTISING** because it is definitely a reference book. When you are looking for information, seconds count. No advertising pages speeds your search.

**IT WILL BE A LIMITED EDITION** because it is designed — like other reference books — for a specific purpose.

It is only for those who can use it to good advantage in the prosecution of their duties.

**FREE DISTRIBUTION** to Advertising Agencies with Aeronautical Accounts, and to Aeronautical Industry Officials in the United States, Canada, South America and other Countries. This directory is a non-profit proposition to us, but you can profit by its use.

**WE SUGGEST** that you reserve your copy now. Please use your business letterhead.



PRODUCTS OF AN ORGANIZATION  
SPECIALIZING IN AERONAUTICAL PUBLICATIONS

515 MADISON AVE., NEW YORK 22, N. Y.

**REVISTA  
AEREA**

**6**

**YEARS OLD  
AND GOING STRONG**



**An AERO DIGEST publication . .**

... printed in Spanish and circulated throughout South America, Central America, Mexico and Cuba to Government Presidents, Cabinet Members, Staffs; Governors of States or Provinces and other Officials and Employees; to Military and Naval Air Corps Commanders, Staffs, Procurement Divisions; to

Air Bases, Commanders, Staffs; to Military Aviation Factories and employees; to Government Aviation Schools, Commanders, Staffs; to Pilots and Mechanics, to Ambassadors or Ministers and Staffs; to Air, Military, Naval, Commercial Attaches, Consulates; to Governmental Departments of Civil Aeronautics; to Airports, Executives, Engineers and Employees; to Fixed Base Operators, Civil Aviation Schools and Staffs; to Air Transport Companies, Executives, Operations Superintendents, Pilots, Mechanics and Employees; to Aero Clubs and their Members, to Commercial and Private Pilots and Plane Owners; to Companies and Individuals interested in Aviation; to Importers, Distributors, Manufacturers, Engineers, Manufacturers' Representatives; to Aviation Divisions of Oil Companies; to Chambers of Commerce; in short, to Everybody in Latin America interested in aviation, and in what you have to sell in that growing and prosperous market. REVISTA AEREA reaches the people who can do business with you — the people you want to reach. Its editorial content and the type of advertising it carries bears out this statement: "If you have a quality product to sell in Latin America, you can sell it through REVISTA AEREA."



**PRODUCTS OF AN ORGANIZATION  
SPECIALIZING IN AERONAUTICAL PUBLICATIONS**

**515 MADISON AVE., NEW YORK 22, N. Y.**

# DIRECTORY OF AIRCRAFT AND AIRCRAFT ENGINE MANUFACTURERS

---

## MANUFACTURERS OF AIRCRAFT

---

### AIRPLANES

---

#### AERONCA AIRCRAFT CORP.,

Municipal Airport, Middletown, O.  
PERSONNEL: C. I. Friedlander, Pres.; E. Sutherland, V. Pres.; J. W. Friedlander, V. Pres. & Gen. Mgr.; E. H. Wideman, V. Pres. & Pur. Dir.; A. H. Helmers, Secy. & Treas.; E. P. Kennedy, Prod. Mgr.; P. E. Linzie, Pers. Dir.; B. L. Hinds, Pub. Dir. & Adv. Mgr.; W. D. Hall, Chief Engr.; E. R. Burn, Dir. Engrg. & Research.

#### ANDOVER KENT AVIATION CORP.,

Allen Ave., New Brunswick, N. J.  
PERSONNEL: J. J. Brooks, Pres.; W. L. Smith, V. Pres. & Gen. Mgr.; I. V. Schaefer, Secy. & Treas.; R. R. Vineyard, Prod. Mgr.; J. F. Monroe, Pur. Dir.; E. E. Swarthout, Pers. Dir.; L. N. Smithline, Chief Engr.

#### ATLANTIC DIESEL CORP.,

401 Codwise Ave., New Brunswick, N. J.  
PERSONNEL: J. S. Johnson, Pres.; Q. S. Cabot, V. Pres.; J. E. Pakenham, Prod. Mgr.; R. F. Sturgis, Sales Mgr.; F. Mather, Pur. Dir.; J. F. Rowe, Pers. Dir.; W. A. Johns, Chief Engr.

#### BEECH AIRCRAFT CORP., Wichita, Kans.

PERSONNEL: W. H. Beech, Pres.; R. K. Beech, V. Pres. & Pur. Dir.; J. P. Gaty, V. Pres. & Gen. Mgr.; T. A. Wells, V. Pres. & Chief Engr.; O. A. Beech, Secy. & Treas.; H. D. MacKinnon, Jr., Prod. Mgr.; W. M. Bashaw, Outside Prod. Mgr.; C. B. Wootten, Sales Mgr.; W. E. Blazier, Pers. Dir.; W. H. McDaniel, Pub. Dir. & Adv. Mgr.

#### BELL AIRCRAFT CORP.,

2050 Elmwood Ave., Buffalo 7, N. Y.  
PERSONNEL: L. D. Bell, Pres. & Gen. Mgr.; C. L. Beard, V. Pres. & Exec. Asst. to Pres.; R. P. Whitman, First V. Pres. & Gen. Mgr., Niagara Falls Div.; O. L. Woodson, V. Pres. & Gen. Mgr., Georgia Div.; H. E. Collins, V. Pres. & Asst. Mgr., Georgia Div.; D. G. Forman, Exec. Asst. to the Pres.; L. F. Sperry, Treas.; J. Berry, Jr., Compt.; S. E. Fitzgerald, Pub. Rel. Dir.; H. H. Johnson, Adv. Mgr.; A. W. Sawyer, Gen. Counsel.

#### BELLANCA AIRCRAFT CORP.,

New Castle, Del.  
PERSONNEL: J. H. Jouett, Pres.; L. C. Milburn, V. Pres. & Gen. Mgr.; H. L. Thompson, Secy., Sales Mgr. & Adv. Mgr.; S. S. Arsh, Treas.; R. F. Wright, Pur. Dir.; I. H. Brinton, Pers. Dir.; W. P. Searcross, Pub. Dir.; A. F. Haiduck, Chief Engr.

#### BOEING AIRCRAFT CO., Seattle, Wash.

PERSONNEL: C. L. Egtvedt, Ch.; P. G. Johnson, Pres.; H. O. West, V. Pres.-Prod.; W. E. Beall, V. Pres.-Engrg.; J. P. Murray, V. Pres. & Wash. Rep.; F. P. Laudan, V. Pres. & Renton Div. Mgr.; H. E. Bowman, Secy. & Treas.; F. B. Collins, Sales Mgr.; F. D. Weaver, Pers. Mgr.; H. Mansfield, Pub. Rel. Mgr.; C. M. Cleveland, Adv. Mgr.; C. E. French, Ind. Rel. Mgr.; C. B. Gracey, Material Mgr.; E. C. Wells, Chief Engr.

#### Wichita Div., Wichita, Kans.

PERSONNEL: P. G. Johnson, Pres.; J. E. Schaefer, V. Pres. & Gen. Mgr.; C. Barron, Asst. Secy. & Asst. Treas.; H. Olson, Prod. Mgr.; L. G. Sinning, Pur. Dir.; G. Trombold, Pers. Dir.; G. L. Findlay, Pub. Dir.; H. Zipp, Chief Engr.

#### BREWSTER AERONAUTICAL CORP.,

Northern Blvd. & 35th St., Long Island City, N. Y.

PERSONNEL: H. J. Kaiser, Pres.; Z. Soucek, V. Pres., Sales Mgr., Pub. Dir. & Adv. Mgr.; P. Lockwood, Secy.; A. B. Cipriani, Controller; J. A. Mitchell, Gen. Mgr.-Prod.; E. J. O'Donnell, Service Dir.; R. A. Cone, Dir. Labor Rel.; F. Lord, Pur. Dir.; G. J. Glehan, Pers. Dir.; G. W. Hardman, Chief Engr.; H. O. Fallon, Ind. Rel. Dir.; G. Luburg, Factory Mgr., Long Island City, N. Y., Div.; C. Santore, Factory Mgr., Johnsville, Pa., Div.

#### CESSNA AIRCRAFT CO.,

5800 Franklin Rd., Wichita, Kans.  
PERSONNEL: D. L. Wallace, Pres. & Gen. Mgr.; D. S. Wallace, Exec. V. Pres. & Treas.; F. Boettger, Secy. & Controller; D. Roskam, Prod. Mgr.; D. Flower, Sales Mgr.; E. Wooley, Pur. Dir.; M. E. Russ, Pers. Dir.; D. Valentine, Adv. Mgr. & Dir. Pub. Rel.; T. Salter, Chief Engr.

#### COMMONWEALTH AIRCRAFT, INC.,

Fairfax Airport, Kansas City 17, Kans.  
PERSONNEL: R. Voyes, Pres.; W. W. Moss, Secy.; J. E. Vigus, Asst. Treas.; J. Farkas, Gen. Mgr. & Factory Mgr.; R. I. Hale, Prod. Mgr.; G. S. Hancock, Jr., Sales Mgr.; M. M. Joffe, Pur. Dir.; M. Bezner, Pers. Dir.; C. E. Rowland, Chief Engr.

**SERVING THE SERVICES WITH PRODUCTS OF  
DESIGN SIMPLICITY**



\*ISOdraulic REMOTE CONTROL SYSTEMS

FLUID METERING PUMPS—Capacities from 0.5 to 30 GPH

SOLENOID VALVES 2, 3 & 4-way



ADEL CLIPS—Over 9,000 types and sizes. 150 million in service

"MIGHTY MIDGET," 4-way hydraulic selector valve.



*Design Simplicity* at ADEL means (1) reducing to simplest terms (2) standardizing (3) manufacturing with greatest precision. Add these up and you get smaller size, lighter weight, longer life and superior performance.

**ADEL**  
PRECISION PRODUCTS CORP.  
*Barbark, California*  
*Huntington, W. Va.*  
Seattle, Wash., Detroit, Mich., Hagerstown, Md.

**FOR YOUR BEST INTEREST BUY WAR BONDS**



**CONSOLIDATED VULTEE AIRCRAFT CORP., San Diego, Calif.**

PERSONNEL: T. M. Girdler, Ch. of Board; H. Woodhead, Pres.; R. H. Fleet, Consultant; E. N. Gott, A. H. Schaad, D. G. Fleet, Assts. to Pres.; I. M. Laddon, Exec. V. Pres.; C. T. Leigh, V. Pres.; C. W. Perelle, V. Pres.-Mfg.; F. A. Gallery, V. Pres.-Finance; W. M. Shanahan, Secy. & Treas.; V. Schorlemmer, Controller; F. A. Lauerman, Ind. Rel. Dir.; F. A. Learman, Gen. Sales Mgr.; A. W. Larsen, Pur. Dir.; A. J. Foristall, Pub. Rel.; H. A. Sutton, Engrg. Dir.

**CULVER AIRCRAFT CORP., 600 E. 35th St., Wichita 1, Kans.**

PERSONNEL: C. G. Yankey, Pres.; W. H. Beech, H. S. Kingsley, V. Pres.; T. B. Woodbury, V. Pres. & Gen. Mgr.; A. W. Mooney, V. Pres. & Chief Designer; V. M. Laing, Secy.; F. M. Farrell, Treas.; W. W. Taylor, Sales Mgr.; R. C. Faris, Pur. Dir.; J. W. Stephens, Pers. Dir.

**CURTISS-WRIGHT CORP., 30 Rockefeller Plaza, New York 20, N.Y.**

PERSONNEL: G. W. Vaughan, Pres.; G. M. Williams, Sr. V. Pres.; R. J. Lindquist, J. A. B. Smith, M. B. Gordon, B. S. Wright, F. H. Harrison, E. J. Harrington, C. W. France, R. L. Earle, C. W. Loos, W. F. Goulding, S. D. Irwin, C. I. Morton, V. Pres.; E. S. Cramer, Secy. & Treas.; W. V. C. Auser, Pers. Dir.; I. Willis, Ind. Rel. Dir.; H. E. Lawrence, Pub. Rel. Dir.; M. E. Nevils, Pub. Dir.

**Buffalo Plants**

PERSONNEL: B. S. Wright, V. Pres.; J. P. Healy, Treas.; W. Davey, Gen. Mgr.; E. J. Ducayet, Contracts Mgr.; L. W. Smead, Pur. Dir.; F. N. Farrar, Jr., Pers. Dir.; C. H. Augspurger, Pub. Dir. & Adv. Mgr.; G. A. Page, Jr., Acting Chief Engr.; E. F. Drollinger, Factory Mgr., Plant 1; A. F. Wieland, Factory Mgr., Plant 2.

**St. Louis, Mo., Plant**

PERSONNEL: C. W. France, V. Pres. & Gen. Mgr.; W. E. Nickey, Asst. Gen. Mgr.; T. E. Killeen, Jr., Asst. Gen. Mgr. for Pers. & Ind. Rel.; J. N. Foster, Factory Mgr.; E. A. Warren, Contracts Mgr.; W. M. Reynolds, Controller & Asst. Treas.; O. L. Allman, Pers. Mgr.; W. J. Moulder, Quality Mgr.; R. N. Swanson, Public & Internal Relations Mgr.; W. L. Wells, Chief Engr.

**DOUGLAS AIRCRAFT CO., 3000 Ocean Park Blvd., Santa Monica, Calif.**

PERSONNEL: D. W. Douglas, Pres.; C. A. Cover, Exec. V. Pres.; F. W. Conant, V. Pres.-Mfg.; A. E. Raymond, V. Pres.-Engr.; J. M. Rogers, V. Pres.-Sales; R. V. Hunt, V. Pres.-Compt.; T. C. McMahon, Exec. Secy.; H. P. Grube, Treas.; H. W. Elliott, Gen. Counsel; A. M. Rochlen, Dir. Ind. & Pub. Rel.; S. O. Porter, Dir. Pers.; J. E. Davis, Dir. Plant Protection; D. J. Bosio, Dir. Materiel; H. E. Guerin, Factory Mgr.; A. C. Miller, Factory Supt.; E. F. Burton, Chief Engr.

**El Segundo Plant**

PERSONNEL: T. E. Springer, Factory Mgr.; L. E. Brizzolara, Factory Supt.; E. H. Heine-mann, Chief Engr.

**Long Beach Plant**

PERSONNEL: G. A. Huggins, Factory Mgr.; J. Simpson, Factory Supt.; F. W. Herman, Chief Engr.

**Tulsa Plant**

PERSONNEL: H. O. Williams, Factory Mgr.; H. Ives, Factory Supt.; D. Dunlap, Engrg. Mgr.

**EASTERN AIRCRAFT DIVISION, GENERAL MOTORS CORP., Bloomfield, N. J.**

PERSONNEL: A. L. Hopkins, Plant Mgr.; A. J. MacCutehan, Pers. Dir.; J. H. Clark, Dir. Pur.; C. H. Troy, Dir. Prod. & Mat. Control; R. A. Dey, Dir. Pub. Rel.; R. D. Winkelmeyer, Chief Product Engr.

**1016 W. Edgar Rd., Linden, N. J.**

PERSONNEL: L. C. Goad, Gen. Mgr.; W. G. Kileen, Div. Compt.; R. E. Waldo, Pers. Dir.; J. N. Bird, Pub. Dir.; A. Wescott, Parts & Service Mgr.

**ENGINEERING & RESEARCH CORP., Riverdale, Md.**

PERSONNEL: L. A. Wells, Pres.; M. W. King, V. Pres. & Secy.; W. G. Carroll, Treas.; J. N. Dean, Gen. Mgr.; E. P. Scully, Pur. Agt.; J. E. Richardson, Pers. Dir.; P. C. Wright, Pub. Dir.; F. E. Weick, Chief Engr.

**FAIRCHILD ENGINE & AIRPLANE CORP., 30 Rockefeller Plaza, New York, N. Y.**

PERSONNEL: S. M. Fairchild, Ch. of Board; J. C. Ward, Jr., Pres.; R. S. Boutelle, H. H. Budds, A. P. Adams, V. Pres.; W. H. Schwebel, Secy. & Compt.; W. Wilson, Treas.; J. S. Lowes, Jr., Pub. Rel. Dir.; A. R. Stocker, Foreign Rel. Dir.

**FAIRCHILD AIRCRAFT DIV. OF FAIRCHILD ENGINE & AIRPLANE CORP., Hagerstown, Md.**

PERSONNEL: R. S. Boutelle, V. Pres. & Gen. Mgr.; P. J. Frizzell, Asst. Gen. Mgr.; J. A. Wales, Jr., Asst. to Gen. Mgr.-Pub. Rel.; A. F. Flood, Div. Compt.; P. Harr. Prod. Mgr.; C. F. Slick, Gen. Factory Mgr.; S. A. Angotti, Dir. Pers.; O. R. Perkins, Dir. Proc.; A. J. Thieblot, Chief Engr.

**Burlington, N. C., Plant**

PERSONNEL: L. H. Smith, Gen. Mgr.; C. Wandel, Asst. Compt.; C. A. Adams, Acting Dir. Pers.; N. V. Kritzner, Dir. Proc.; H. S. Jones, Factory Mgr.; M. L. Ham, Dir. Pub. Rel.; G. Evans, Engr. in Charge.

**FLEETWINGS, INC., Bristol, Pa.**

PERSONNEL: F. de Ganahl, Pres.; C. de Ganahl, V. Pres.-Research; I. S. Wilson, V. Pres. & Treas.; C. L. Nielson, Secy.; A. Thompson, Contracts Mgr.; W. E. Strang, Pers. Dir.; P. F. Biklen, Pub. Dir.; R. W. Ayer, Chief Engr.

**FORD MOTOR CO., Dearborn, Mich.**

PERSONNEL: H. Ford, Pres.; H. Ford II, V. Pres.; C. E. Sorensen, V. Pres. & Gen. Mgr.; B. J. Craig, V. Pres. & Treas.; H. L. Moekle, Secy.; H. H. Bennett, Pers. Dir.; J. W. Thompson, Adv. Mgr.; D. S. Roeder, Chief Engr.

**FUNK AIRCRAFT CO., Coffeyville, Kans.**

PERSONNEL: J. C. Funk, Prod. Mgr.; F. Gerdes, Sales Mgr.; N. F. Howard, Pur. Dir.; H. C. Funk, Chief Engr.

**GENERAL AIRCRAFT CORP., 43-02 Ditmars Blvd., Long Island City 5, N. Y.**

PERSONNEL: H. J. Maynard, Jr., Pres.; J. T. Geuting, Jr., L. E. Reisner, H. Fahnestock, Jr., V. Pres.; K. I. Deane, Secy.; E. S. Gremse, Treas.; L. W. Mattson, Sr., Pers. Dir.; P. T. Nickson, Chief Engr.

**GLOBE AIRCRAFT CORP., Fort Worth, Tex.**

PERSONNEL: J. Kennedy, Pres. & Gen. Mgr.; W. Viner, V. Pres.; E. H. Jackson, Secy.; N. N. Oille, Treas.; H. M. Shealey, Prod. Mgr.; N. Nicholson, Sales Mgr.; P. E. Andrews, Pur. Dir.; J. H. Race, Pers. Dir.; L. J. Rowell, Pub. Dir.; C. L. Richhart, Adv. Mgr.; K. H. Knox, Chief Engr.

# From Flying Jeeps to Leviathans of the Air

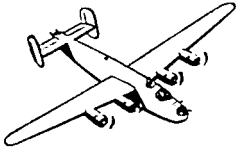

**LIBERATOR** ... 4-engine bomber

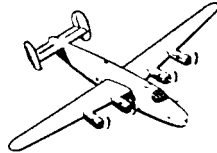

**LIBERATOR EXPRESS** ... transport

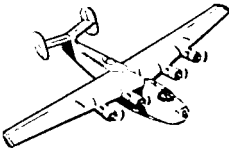

**CORONADO** ... patrol bomber

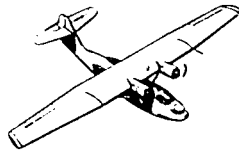

**CATALINA** ... patrol bomber

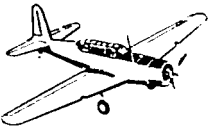

**VALIANT** ... basic trainer

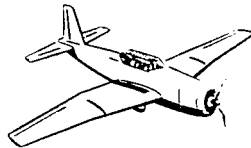

**VENGEANCE** ... dive bomber

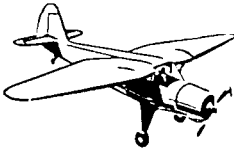

**RELIANT** ... navigation trainer

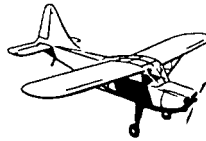

**SENTINEL** ... "Flying Jeep"

**W**HEN VICTORY has been won, Consolidated Vultee Aircraft Corporation will be in a position to provide the post-

war equivalent of these planes, from small privately owned "air flivvers" to huge, trans-oceanic cargo-and-passenger planes.

## CONSOLIDATED VULTEE

San Diego, Calif.  
Vultee Field, Calif.  
Tucson, Ariz.

Fort Worth, Texas  
New Orleans, La.  
Nashville, Tenn.

Louisville, Ky.  
Wayne, Mich.  
Dearborn, Mich.

Allentown, Pa.  
Elizabeth City, N. C.  
Miami, Fla.

*Member, Aircraft War Production Council*

## SEATS FOR THE MIGHTY

SIKORSKY 542  
PASSENGER No. 150-1



NORTH AMERICAN AT-6  
PILOT No. 196



CURTISS WRIGHT C-46  
RADIO OPERATOR No. 199



CONSOLIDATED C-87  
PILOT No. 225



LOCKHEED LODESTAR  
RADIO OPERATOR No. 173-2



WARREN  
MARTHUR

DOUGLAS C-54A  
PASSENGER No. 154-2



BREWSTER BERMUDA  
REAR GUNNER No. 194-A



MARTIN B-26  
PILOT No. 62



WARREN MARTHUR CORPORATION  
ONE PARK AVENUE NEW YORK CITY

DESIGNERS ENGINEERS AND MANUFACTURERS OF AIRCRAFT AND NAVY SEATING



## BIG BRUTES

BUY MORE WAR BONDS

### Douglas Builds All Three

When United Nations air strategy called for concentration on heavy bombers and transports, only Douglas was chosen to produce all three current 4-engine land plane types: Douglas' own C-54 Skymaster Combat Transport (bottom), the B-24 Liberator Bomber and the Flying Fortress. Douglas production of "big brutes" has been on schedule or ahead of schedule, in addition to fabulous output of more other types of aircraft than any other manufacturer.

# DOUGLAS

AIRCRAFT COMPANY • SANTA MONICA, CALIF.

LONG BEACH, EL SEGUNDO & DAGGETT, CALIF., TULSA, OKLAHOMA, OKLAHOMA CITY, CHICAGO  
 Member, Aircraft War Production Council, Inc.

**GOODYEAR AIRCRAFT CORP.,** Akron 15, O.  
**PERSONNEL:** P. W. Litchfield, Pres.; E. J. Thomas, P. E. H. Leroy, V. Pres.; H. E. Blythe, V. Pres. & Gen. Mgr.; R. DeYoung, V. Pres.-Prod.; K. Arnstein, V. Pres.-Engr.; T. Knowles, V. Pres.-Sales; H. L. Hyde, Secy.; Z. C. Oceland, Treas.; C. H. Brook, Compt.; L. E. Judd, Dir. Pub. Rel.; J. K. Hough, Dir. Adv.

**GRUMMAN AIRCRAFT ENGINEERING CORP.,** Bethpage, N. Y.  
**PERSONNEL:** L. R. Grumman, Pres.; L. A. Swirbul, Exec. V. Pres.; W. T. Schwendler, B. A. Gillies, E. C. Towl, V. Pres.; J. A. Stamm, Secy.; E. W. Poor, Treas.

**HARLOW AIRCRAFT CO.,**  
 620 E. Valley Blvd., Alhambra, Calif.  
**PERSONNEL:** H. F. Keenan, Pres.; F. Der Yuen, V. Pres. & Gen. Mgr.; J. E. Addicott, Jr., V. Pres., Secy. & Sales Mgr.; E. L. McCreary, Treas.; M. J. Hoffman, Prod. Mgr. & Factory Mgr.; R. E. Smith, Pur. Dir.; M. H. Gray, Pers. Dir.; D. C. Mendenhall, Chief Engr.

**HIGGINS AIRCRAFT, INC.,**  
 P. O. Box 32, New Orleans 6, La.  
**PERSONNEL:** A. J. Higgins, Sr., Pres.; J. H. Jouett, Exec. V. Pres.; F. O. Higgins, V. Pres. & Gen. Mgr.; C. P. Fenner, Jr., Secy.; M. J. Gottesman, Treas.; P. N. Beall, Ch. Prod. Engr.; M. P. Chatry, Pur. Dir.; F. S. Reyer, Pers. Dir.; E. T. Waldo, Pub. Dir. & Adv. Mgr.; G. Allward, Chief Aero. Engr.

**HOWARD AIRCRAFT CORP.,**  
 Box 228, St. Charles, Ill.  
**PERSONNEL:** D. Peterkin, Pres.; K. W. Rowe, V. Pres.; C. W. Freitag, V. Pres. & Sales Mgr.; L. M. McBride, Secy.; F. B. Evans, Treas.; E. H. Huff, Works Mgr.; W. Alcott, Asst. Prod. Mgr.; J. Rice, Pur. Dir.; W. T. Wallace, Pers. Dir.; C. Carlson, Acting Chief Engr.

**INTERSTATE AIRCRAFT & ENGINEERING CORP.,** 3443 Wilshire Blvd., Los Angeles, Calif.

**PERSONNEL:** D. P. Smith, Pres.; W. E. Hirtensteiner, V. Pres.-Prod.; W. A. Hite, V. Pres.-Engr.; L. B. Cameron, Secy. & Treas.; J. E. Koster, Pur. Agt.; R. W. Limacher, Pers. Dir.; H. O. Nelson, Pub. Dir.

**KILGEN AIRCRAFT DIV. OF KILGEN ORGAN CO.,** 4443 Cook Ave., St. Louis 13, Mo.

**PERSONNEL:** E. R. Kilgen, Pres. & Gen. Mgr.; M. Hess, V. Pres. & Chief Engr.; E. J. Maruska, Secy. & Asst. Treas.; P. J. Garvey, Prod. Mgr. & Sales Mgr.; J. Weber, Pur. Dir. & Pers. Dir.; M. Bronson, Pub. Dir. & Adv. Mgr.; G. McCandless, Chief Engr.

**LANGLEY AVIATION CORP.,**  
 50 Rockefeller Plaza, New York, N. Y.  
**PERSONNEL:** V. Bendix, Ch. of Board; J. W. Garside, Pres.; M. Jensen, V. Pres.; C. L. MacDonald, Secy. & Treas.; T. W. Robertson, Pur. Dir. & Factory Mgr.; R. Contini, Chief Engr.

**LOCKHEED AIRCRAFT CORP.,**  
 Burbank, Calif.  
**PERSONNEL:** R. E. Gross, Pres.; C. S. Gross, V. Pres. & Gen. Mgr.; C. B. Squier, V. Pres.-Sales & Service; C. Chappellet, V. Pres.-Adm.; H. E. Ryker, V. Pres.-Materiel; C. A. Barker, Jr., V. Pres. & Treas.; L. W. Wulfekuhler, Secy.; H. C. Tallmadge, Gen. Counsel; H. McIntosh, Dir. Management Control; S. Voorhes, Staff Asst. to Pres.; L. K. Schwartz, Asst. to Pres., Sales Mgr. & Pub. Rel. Dir.; K. Smith, Asst. to Pres.-Liaison; R. R. Irwin, Asst. to V. Pres.-Adm.; L. W. Shaw, Asst. to Pres.-Taxation; L. V. Kerber, Contract Officer; R. K. Stunkel, Gen. Service Mgr.; O. P. Graff, Dir., Parts Office; W. W. Aulepp, Dir. Ind. Rel.; J. E. Canaday, Pub. Rel. Mgr.

Plant A  
**PERSONNEL:** M. Short, V. Pres.-Engr.; D. J. Houghton, Works Mgr.; J. B. Wassall, Chief Engr.; C. J. Leisy, Chief Project Engr.

Plant B  
**PERSONNEL:** H. L. Hibbard, V. Pres. & Chief Engr.; L. M. Bach, Works Mgr.; C. L. Johnson, Chief Research Engr.; W. R. Jones, Chief Project Engr.; F. W. Thrane, Engr. Mgr.

**LUSCOMBE AIRPLANE CORP.,**  
 Trenton, N. J.  
**PERSONNEL:** A. C. Hastings, Pres.; C. E. Burgess, V. Pres. & Gen. Mgr.; W. F. Palmer, Secy. & Treas.; L. H. Heckendorn, Prod. Mgr.; R. H. Washburn, Sales Mgr.; F. V. Peberdy, Pur. Dir.; L. P. Taylor, Pers. Dir.; J. Cunningham, Chief Engr.

**MC DONNELL AIRCRAFT CORP.,**  
 Ambassador Bldg., St. Louis 1, Mo.  
**PERSONNEL:** J. S. McDonnell, Pres. & Gen. Mgr.; G. W. Carr, Exec. V. Pres.; L. A. Smith, V. Pres. & Treas.; W. L. Desloge, Asst. Secy.; R. W. Jordan, Asst. to Pres.; H. F. Debandt, Pur. Agt.; H. O. Smith, Ind. Rel. Dir.; C. C. Covington, Chief Engr.; C. F. Marschner, Mgr., Plastics Div.; C. W. Drake, Factory Mgr., St. Louis Div.; F. G. Essig, Factory Mgr., Memphis, Tenn., Div.

**THE GLENN L. MARTIN CO.,**  
 Baltimore, Md.  
**PERSONNEL:** G. L. Martin, Pres.; J. T. Hartson, Exec. V. Pres.; H. T. Rowland, V. Pres.; H. F. Vollmer, Jr., V. Pres.-Mfg.; W. K. Ebel, V. Pres.-Engr.; T. H. Jones, Secy.; M. G. Shook, Treas.; T. B. Soden, Factory Mgr.; C. W. Chidester, Pur. Agt.; D. W. Siemon, Pers. Dir.; A. McBee, Pub. Rel. Dir.

**THE GLENN L. MARTIN-NEBRASKA CO.,**  
 Omaha 1, Nebr.  
**PERSONNEL:** J. T. Hartson, Pres.; G. T. Willey, V. Pres. & Gen. Mgr.; C. S. Miller, Asst. Treas.; R. L. Evans, Prod. Mgr.; R. B. Hartman, Pur. Dir.; G. K. Hammer, Pers. Dir.; T. E. Stephenson, Pub. Dir. & Adv. Mgr.; C. W. Miller, Chief Engr.; J. P. Bailey, Factory Mgr.

**MEYERS AIRCRAFT CO.,**  
 Box 721, Tecumseh, Mich.  
**PERSONNEL:** A. H. Meyers, Pres. & Chief Engr.; C. F. Sage, V. Pres.; B. W. Hoffman, Secy., Treas. & Pur. Dir.; O. Meiers, Prod. Mgr. & Factory Mgr.

**NORTH AMERICAN AVIATION, INC.,**  
 5701 Imperial Highway, Inglewood, Calif.  
**PERSONNEL:** J. H. Kindelberger, Pres. & Gen. Mgr.; L. R. Taylor, Asst. to Pres.; J. L. Atwood, First V. Pres.; R. H. Rice, V. Pres. & Chief Engr.; J. S. Smithson, V. Pres.-Mfg.; R. A. Lambeth, V. Pres. & Treas.; S. G. Anspach, Secy. & Asst. Treas.; M. E. Beaman, Ind. Rel. Dir.; C. J. Hansen, Chief Project Engr.

California Div.  
**PERSONNEL:** R. E. Dawe, Factory Mgr.; E. Starkweather, Dir. Ind. Rel.; R. S. Johnson, Dir. Pub. Rel.; E. C. Bertram, Plant Engr.

Texas Div.  
**PERSONNEL:** H. F. Schwedes, Factory Mgr.; T. H. Beck, Chief Div. Engr.; N. Molinarro, Dir. Ind. Rel.

Kansas Div.  
**PERSONNEL:** H. R. Raynor, Factory Mgr.; F. Branch, Dir. Ind. Rel.; W. A. Spivak, Chief Div. Engr.



## PRODUCTION ON SCHEDULE

The splendid performance of America's aircraft in World War II, is a tribute to the men who make them...as well as those who fly them.

For it takes management, planning, engineering, procurement, tooling, training, skilled workmanship, and coordinated effort of the highest order, to produce planes in adequate quantities... on schedule.

At McDonnell, we *have* met production requirements...on planes, parts, and plastics... *on schedule.*

Behind this successful production

performance is a well-rounded organization of seasoned aircraft executives, engineers, research workers, tooling experts and production specialists... who have passed along the results of many years' experience to thousands of hard-working shop personnel.

An additional factor which has contributed materially to our ability to meet production requirements on schedule, has been our policy of multiplying and facilitating production through sub-contracting.

We shall welcome further opportunities to serve the war effort of America and its fighting Allies.

**McDONNELL** *Aircraft Corporation*  
*Manufacturers of* PLANES · PARTS · PLASTICS \* SAINT LOUIS · MEMPHIS \*



## THE ENGINE THAT IS ALWAYS THERE

Allison-powered planes have been called upon in every major engagement in which our Army has taken part. ★ They have had a hand in every great land victory to our credit. ★ Allison engines always — for dependability and brilliant performance!

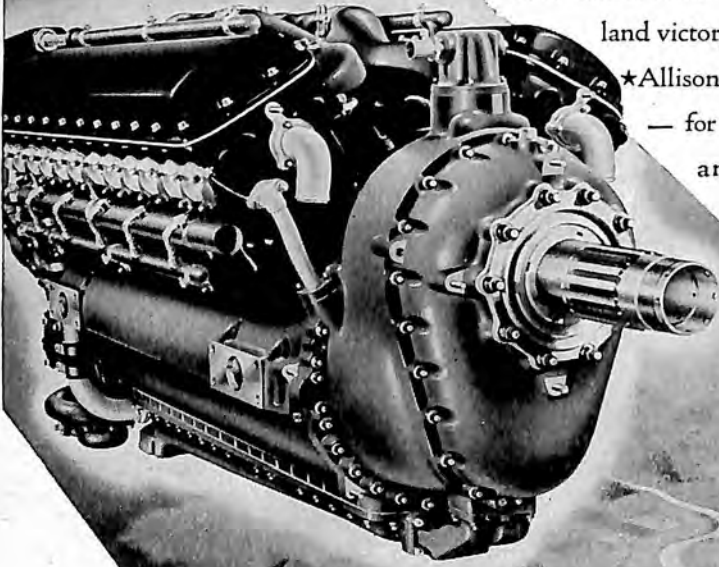

Every Sunday Afternoon  
GENERAL MOTORS  
SYMPHONY  
OF THE AIR  
— NBC Network

LIQUID-COOLED AIRCRAFT ENGINES

*Allison*  
DIVISION OF

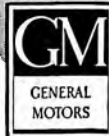

POWERED BY ALLISON:

P-38—Lightning • P-39—Airacobra  
P-40—Warhawk • A-36 and P-51—Mustang

★  
KEEP AMERICA STRONG  
BUY MORE WAR BONDS

# 3 versatile Lockheeds do more than 24 important war jobs

- |                               |                              |
|-------------------------------|------------------------------|
| 1. High-altitude fighter.     | 12. Patrol bomber.           |
| 2. Photographic plane.        | 13. Torpedo carrier.         |
| 3. Long-range escort fighter. | 14. Dive bomber.             |
| 4. Paratroop transport.       | 15. Personnel transport.     |
| 5. Air freighter.             | 16. Low-level attack bomber. |
| 6. Target tow-plane.          | 17. Mine layer.              |
| 7. Glider tow-plane.          | 18. Smoke screen layer.      |
| 8. Fighter bomber.            | 19. Night fighter.           |
| 9. Interceptor.               | 20. Tank buster.             |
| 10. Pursuit.                  | 21. Skip bomber.             |
| 11. Reconnaissance bomber.    | 22. Sub buster.              |
|                               | 23. Sky ambulance.           |
|                               | 24. Officer transport.       |



**1. LOCKHEED CONSTELLATION,** fast, new, cargo transport that will bring postwar air travel to bus rates.



**2. LOCKHEED PV-1 VENTURA,** U. S. Navy bomber. Known as B-34 in U. S. Army and Ventura in the R.A.F.



**3. LOCKHEED P-38 "LIGHTNING,"** two-engine, twin-boom fighter in service on all important battle fronts.

**Versatility** is as much a Lockheed characteristic as is *dependability*. Well-engineered construction permits each airplane to do more than just the job for which it was built. To tell which job these airplanes do would violate military secrecy, but here are 24 they are doing well!

LOOK TO **Lockheed** FOR LEADERSHIP

LOCKHEED AIRCRAFT CORPORATION, BURBANK, CALIFORNIA

**NORTHROP AIRCRAFT, INC.,**

1001 E. Broadway, Hawthorne, Calif.  
 PERSONNEL: L. T. Cohu, Ch. of Board & Gen. Mgr.; J. K. Northrop, Pres. & Chief Engr.; G. H. Irving, V. Pres. & Asst. Mgr.; C. N. Monson, V. Pres. & Treas.; G. L. Sterling, Jr., V. Pres. & Gen. Counsel; T. C. Coleman, V. Pres.; M. W. Stephens, Secy.; P. I. Chase, Pur. Agt.; W. T. Gage, Pers. Dir.; C. E. Apponyi, Pub. Dir.

**NORTHWESTERN AERONAUTICAL CORP.,**  
Wold-Chamberlain Airport, Minneapolis, Minn.

PERSONNEL: J. E. Parker, Pres. & Gen. Mgr.; G. H. Plufka, V. Pres. & Treas.; R. W. Whittingham, Secy. & Prod. Mgr.; A. Molde, Pur. Dir.; D. H. Whitmore, Pers. Dir.; W. S. Stern, Pub. Dir.

**PHILLIPS AVIATION CO., 1525 Monterey Rd., South Pasadena, Calif.**

PERSONNEL: J. A. Phillips, Jr., Pres. & Gen. Mgr.; F. R. Phillips, V. Pres.; L. M. Phillips, Secy.; D. B. Morgan, Treas.; A. Johnson, Pur. Agt.; H. J. Coffman, Pub. Dir.; O. A. Phillips, Chief Engr.

**PIPER AIRCRAFT CORP., Lock Haven, Pa.**

PERSONNEL: W. T. Piper, Pres. & Treas.; T. Weld, V. Pres., Gen. Mgr., Pers. Dir., Pub. Dir. & Adv. Mgr.; W. T. Piper, Jr., Secy.; H. Eckman, Prod. Mgr.; W. B. St. John, Sales Mgr.; R. C. McKissick, Pur. Dir.; W. C. Jamouneau, Chief Engr.

**PRATT, READ & CO., INC.,**  
Deep River, Conn.

PERSONNEL: J. A. Gould, Pres., Treas. & Gen. Mgr.; H. L. deForest, J. H. Gould, V. Pres.; G. C. Seeley, V. Pres. & Secy.; P. H. Comstock, V. Pres. & Sales Mgr.; H. E. Jopson, Prod. Mgr.; R. W. Stevens, Pur. Dir.; J. S. Dunn, Pers. Dir.; N. R. Gould, Pub. Dir.; J. W. Tumavicus, Chief Engr.

**REPUBLIC AVIATION CORP.,**  
Farmingdale, Long Island, N. Y.

PERSONNEL: A. Marchev, Pres.; C. H. Miller, M. I. Peale, V. Pres. & Div. Mgrs.; J. A. Kartveli, V. Pres. & Chief Engr.; H. W. Flichinger, J. J. Ryan, V. Pres.; T. Davis, Secy. & Treas.; A. L. Kress, A. Peck, S. Mambert, Assts. to Pres.; D. M. Parker, Dir. of Military Contracts; R. H. McMann, Procurement Mgr.; J. E. Duffield, Jr., Adv. Dir.; M. C. Monroe, Ind. Rel. Dir.; H. Lasker, Works Mgr.; I. Keough, Factory Mgr.; C. Kucyn, Prod. Mgr.; L. Cunningham, Pur. Agt.; G. Sleeper, Post War Planning; H. Albert, Methods Engr.; R. Bowman, Design Engr.; R. Berg, Research Engr.; J. Gitz, Prod. Engr.; R. L. Bortner, Adm. Engr.; D. W. Weed, Project Engr.; R. W. Miller, Commercial Projects Engr.

**RYAN AERONAUTICAL CO.,**  
Lindbergh Field, San Diego 12, Calif.

PERSONNEL: T. C. Ryan, Pres., Treas. & Gen. Mgr.; E. D. Prudden, V. Pres.; E. Molloy, V. Pres.-Mfg.; G. C. Woodard, Secy.; J. C. Noakes, Controller; G. E. Barton, Factory Mgr.; S. C. Breder, Sales Mgr.; O. F. Rigley, Pur. Dir.; W. F. Persons, Ind. Rel. Dir.; W. Wagner, Pub. Dir. & Adv. Mgr.; B. T. Salmon, Chief Engr.

**ST. LOUIS AIRCRAFT CORP.,**

8000 N. Broadway, St. Louis, Mo.  
 PERSONNEL: E. B. Meissner, Pres. & Gen. Mgr.; L. S. Lutton, V. Pres. & Chief Engr.; E. C. Wrausmann, V. Pres.; J. Tringl, Secy.; E. Augustine, Treas.; W. A. Fitzgerald, Pur. Dir.

**SPARTAN AIRCRAFT CO.,**

1900 N. Sheridan Rd., Tulsa, Okla.  
 PERSONNEL: J. P. Getty, Pres.; M. W. Balfour, V. Pres.; F. T. Hopp, Secy. & Treas.; G. F. Shortess, Contract Officer; J. Bredouw, Pur. Dir.; A. Reitherman, Asst. Plant Mgr.; F. Stewart, Chief Engr.

**STINSON DIV., VULTEE AIRCRAFT, INC.,**  
Wayne, Mich.

PERSONNEL: T. M. Girdler, Ch. of Board; H. Woodhead, Pres.; D. G. Fleet, Exec. V. Pres.; H. Fenwick, I. M. Laddon, V. C. Schorlemmer, V. Pres.; T. C. Sullivan, Secy.; L. K. Grant, Treas.; G. T. Bovee, Controller; A. E. Shelton Div. Mgr.; D. M. Trask, Dir. Ind. Rel.; W. A. Mara, Sales Mgr.; Hill & Knowlton, Dir. Pub. Rel.

**TAYLORCRAFT AVIATION CORP.,**  
Alliance, O.

PERSONNEL: J. C. Hart, Pres.; C. W. Elkins, Asst. to Pres.-Sales; R. H. Wendt, V. Pres.-Engrg.; K. W. Tibbits, V. Pres.-Mfg.; D. L. Zacharias, Secy. & Treas.; M. W. Third, Asst. Treas. & Pers. Dir.; J. F. Masterson, Pub. Dir.; A. J. Dodge, Pur. Dir.

**UNITED AIRCRAFT CORP.**

400 S. Main St., East Hartford, 8, Conn.  
 PERSONNEL: H. M. Horner, Pres.; S. A. Stewart, C. J. McCarthy, V. Pres.; F. B. Rentschler, Ch.; E. E. Wilson, R. Walsh, Vice Ch.; J. F. McCarthy, Controller; L. D. Lyman, Asst. to Ch.; C. H. Chatfield, Secy.; C. L. Gault, Treas.; F. E. Burnham, Gen. Acct.; N. V. Clements, Dir. Adv. & Pub.

**UNIVERSAL MOULDED PRODUCTS CORP.,**  
Bristol, Va.

PERSONNEL: T. H. McKoy, Jr., Pres.; G. M. Curtis, V. Pres., Gen. Mgr. & Prod. Mgr.; R. L. Reed, Secy.; H. W. Page, Treas.; G. D. Spinks, Pur. Dir.; M. T. Repass, Pers. Dir.; R. J. Nebesar, Chief Engr.

**CHANCE VOUGHT AIRCRAFT DIV.,**  
UNITED AIRCRAFT CORP., 550 Main St., Stratford, Conn.

PERSONNEL: H. M. Horner, Pres.; S. A. Stewart, C. J. McCarthy, V. Pres.; C. H. Chatfield, Secy.; C. L. Gault, Treas.; J. F. McCarthy, Controller; N. V. Clements, Dir. Adv. & Pub.; R. B. Beisel, Gen. Mgr.; G. V. Anderson, Pers. Supervisor; F. J. Delear, Pub. Rep.; J. M. Shoemaker, Chief Engr.

---

**ROTOR AIRCRAFT**

---

**ATLANTIC DIESEL CORP.,**

401 Codwise Ave., New Brunswick, N. J.  
 PERSONNEL: J. S. Johnson, Pres.; Q. S. Cabot, V. Pres.; J. E. Pakenham, Prod. Mgr.; R. F. Sturgis, Sales Mgr.; F. Mather, Pur. Dir.; J. F. Rowe, Pers. Dir.; W. A. Johns, Chief Engr.

**COMMONWEALTH AIRCRAFT, INC.,**

Fairfax Airport, Kansas City 17, Kans.  
 PERSONNEL: R. Voyes, Pres.; W. W. Moss, Secy.; J. E. Vigus, Asst. Treas.; J. Farkas, Gen. Mgr. & Factory Mgr.; R. I. Hale, Prod. Mgr.; G. S. Hancock, Jr., Sales Mgr.; M. M. Joffe, Pur. Dir.; M. Bezner, Pers. Dir.; C. F. Rowland, Chief Engr.

**G & A AIRCRAFT, INC., Willow Grove Pa.,**

PERSONNEL: V. H. Frazier, Pres. & Gen. Mgr.; G. B. Knecht, V. Pres. & Treas.; J. C. Ainsworth, V. Pres. & Pur. Dir.; J. P. Perry, V. Pres. & Chief Engr.; G. M. Stiegler, Secy.; A. W. Keiser, Prod. Mgr.; L. K. Behlert, Pers. Dir.; R. C. Beck, Pub. Dir.

***We make planes***

*Mitchell bomber ... first over Tokyo—*



***that are speeding***

*P-51 Mustang fighter ... world's fastest*



***the Victory on***

*AT-6 Texan combat trainer*



***every war-front***

**North American Aviation**  
***Sets the Pace!***

# AN INTRICATE PRECISION WELD

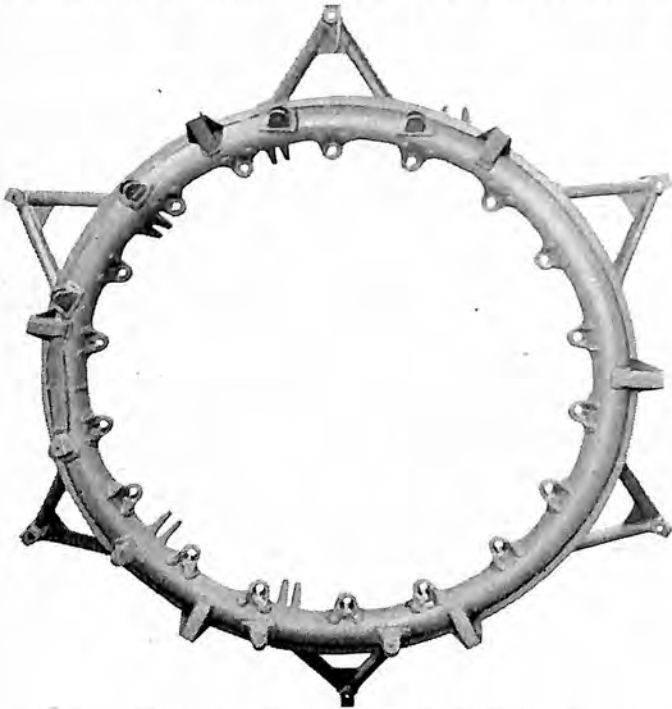

*Typical welded engine mount precision  
welded by Aircraft Welders, Inc.*

Leading airframe manufacturers have complete confidence in our ability to produce *exactly* what they want. Our experience, skill and exclusive processes assure absolute compliance with manufacturers' specifications.

**OUR CUSTOMER LIST LOOKS LIKE "WHO'S WHO"**

BOEING AIRCRAFT CO.	CURTISS-WRIGHT CORP.
CONSOLIDATED-VULTEE	BELL AIRCRAFT CORP.
BEECH AIRCRAFT CORP.	WACO AIRCRAFT CORP.
CANADIAN CAR & FDY.	GLOBE AIRCRAFT CORP.
FAIRCHILD AIRCRAFT CO. OF CANADA	

*Inquiries are invited*

## AIRCRAFT WELDERS, INC.

MANUFACTURERS OF AIRPLANE PARTS

WICHITA, KANSAS



**KEEP YOUR EYE ON** *Tomorrow's Horizons* The Future

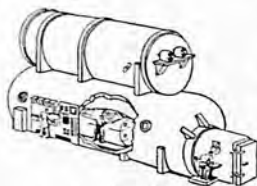

An altitude chamber in which flight conditions at more than 40,000 feet altitude can be simulated and one of the world's most modern wind tunnels are part of the equipment at the new Curtiss Research Laboratory.



Beyond measure are the engineering advances, the improvements in manufacturing methods, which are the product of Curtiss-Wright's vast wartime program. When war is done, this rich experience will give the world safer, speedier, more luxurious airliners—swifter, more economical cargo carriers.

LOOK TO THE SKY, AMERICA!  
**CURTISS-WRIGHT**  
*Corporation*  
 AIRPLANE DIVISION  
 BUFFALO • COLUMBUS • ST. LOUIS • LOUISVILLE



**KELLETT AIRCRAFT CORP.,**

Lansdowne Ave., Upper Darby, Pa.  
 PERSONNEL: W. W. Kellett, Pres.; W. L. Wilson, Asst. to Pres., Pub. Dir. & Adv. Mgr.; R. G. Kellett, V. Pres.; H. H. Savage, Secy.; W. R. Yarnall, Treas.; W. L. Schrader, Factory Mgr.; J. E. Robertson, Pur. Dir.; R. J. Riddle, Pers. Dir. & Dir. Ind. Rel.; R. H. Prewitt, Chief Engr.

**NASH-KELVINATOR CORP.,**

14250 Plymouth Rd., Detroit 32, Mich.  
 PERSONNEL: G. W. Mason, Pres.; H. G. Perkins, V. Pres.; H. J. Mellum, Secy.; G. V. Egan, Treas.; C. T. Lawson, Sales Mgr., Kelvinator Div.; L. F. Skutt, Sales Mgr., Nash Div.; B. P. Watkins, Pur. Dir.; H. G. Little, Dir. of Pub. Rel.; C. J. Coward, Adv. Mgr., Kelvinator Div.; N. Nyland, Adv. Mgr., Nash Div.; F. F. Kishline, Chief Engr.

**SIKORSKY AIRCRAFT, DIV. OF UNITED AIRCRAFT CORP.,** South Ave., Bridgeport, Conn.

PERSONNEL: H. M. Horner, Pres.; S. A. Stewart, C. J. McCarthy, V. Pres.; C. H. Chatfield, Secy.; C. L. Gault, Treas.; J. F. McCarthy, Controller; N. V. Clements, Dir. Adv. & Pub.; B. L. Whelan, Gen. Mgr.; I. I. Sikorsky, Engrg. Mgr.; M. E. Gluhareff, Chief Engr.

**GLIDERS****ALLIED AVIATION CORP.,** Baltimore, Md.

PERSONNEL: R. E. Breed, III, Pres.; C. J. MacGarvey, Exec. V. Pres. & Treas.; J. C. Gaffin, V. Pres. & Sales Mgr.; E. V. Chartrand, Secy.; J. C. Richardson, Factory Mgr.; A. Arendt, Pur. Dir.; R. R. Scott, Pers. Dir.; L. L. Collins, Chief Engr.

**BABCOCK AIRCRAFT CORP.,** Deland, Fla.

PERSONNEL: M. B. Harvey, Pres. & Gen. Mgr.; V. C. Babcock, V. Pres. & Chief Engr.; W. J. Deegan, Jr., Secy. & Treas.; R. E. Bewley, Pur. Agt.; H. G. Gray, Pers. Dir.

**BRISTOL AERONAUTICAL CORP.,**

1311 Chapel St., New Haven, Conn.  
 PERSONNEL: A. L. Patterson, Pres.; J. J. O'Grady, Jr., V. Pres. & Secy.; W. J. Parent, Pers. Dir.; R. M. Ressler, Pur. Dir.

**CALIFORNIA AERO GLIDER CO. INC.,**

1829 W. 62nd St., Los Angeles 44, Calif.  
 PERSONNEL: A. V. Marchetti, Pres. & Gen. Mgr.; R. J. Parody, Exec. V. Pres., Secy. & Sales Mgr.; V. Jensen, Chief Engr.

**COMMONWEALTH AIRCRAFT, INC.,**

Fairfax Airport, Kansas City 17, Kans.  
 PERSONNEL: R. Voyes, Pres.; W. W. Moss, Secy.; J. E. Vigus, Asst. Treas.; J. Farkas, Gen. Mgr. & Factory Mgr.; R. I. Hale, Prod. Mgr.; G. S. Hancock, Jr., Sales Mgr.; M. M. Joffee, Pur. Dir.; M. Bezner, Pers. Dir.; C. E. Rowland, Chief Engr.

**CULVER AIRCRAFT CORP.,**

600 E. 35th St., Wichita, Kans.  
 PERSONNEL: C. G. Yankey, Pres.; W. H. Beech, V. Pres.; V. M. Laing, Secy.; F. M. Farrell, Treas.; T. B. Woodbury, Gen. Mgr.; R. R. Nadal, Sales Mgr.; R. C. Faris, Pur. Agt.; A. W. Mooney, Chief Engr.

**FORD MOTOR CO.,** Dearborn, Mich.

PERSONNEL: H. Ford, Pres.; H. Ford, II, V. Pres.; C. E. Sorensen, V. Pres. & Gen. Mgr.; B. J. Craig, V. Pres. & Treas.; H. L. Moeckle, Secy.; H. H. Bennett, Pers. Dir.; J. W. Thompson, Adv. Mgr.; D. S. Roeder, Chief Engr.

**FRANKFORT SAILPLANE CO.,** Joliet, Ill.

PERSONNEL: G. F. Getz, Jr., Pres.; R. E. Gage, V. Pres. & Gen. Mgr.; J. C. Battaglia, V. Pres.-Engrg.; S. R. Corcoran, V. Pres.-Dev. & Research; B. C. Hightower, Secy. & Treas.; J. B. Phelps, Prod. Mgr.; E. F. Mangold, Pur. Dir.; A. S. Brennan, Pers. Dir.

**G & A AIRCRAFT, INC.,** Willow Grove, Pa.

PERSONNEL: V. H. Frazier, Pres. & Gen. Mgr.; G. B. Knecht, V. Pres. & Treas.; J. C. Ainsworth, V. Pres. & Pur. Dir.; J. P. Perry, V. Pres. & Chief Engr.; G. M. Stiegler, Secy.; A. W. Keiser, Prod. Mgr.; L. K. Behlert, Pers. Dir.; R. C. Beck, Pub. Dir.

**GENERAL AIRCRAFT CORP.,**

43-02 Ditmars Blvd., Long Island City 5, N. Y.

PERSONNEL: H. J. Maynard, Jr., Pres.; J. T. Geuting, Jr., L. E. Reiser, H. Fahnestock, Jr., V. Pres.; K. I. Deane, Secy.; E. S. Gremse, Treas.; L. W. Mattson, Sr., Pers. Dir.; P. T. Nickson, Chief Engr.

**KILGEN AIRCRAFT DIV. OF KILGEN AIRCRAFT CO.,** 4443 Cook Ave., St. Louis, Mo.

PERSONNEL: E. R. Kilgen, Pres. & Gen. Mgr.; M. Hess, V. Pres. & Chief Engr.; E. J. Maruska, Secy. & Asst. Treas.; P. J. Garvey, Prod. Mgr. & Sales Mgr.; J. Weber, Pur. Dir. & Pers. Dir.; M. Bronson, Pub. Dir. & Adv. Mgr.; G. McCandless, Chief Engr.

**NORTHWESTERNAERONAUTICAL CORP.,** Wold-Chamberlain Airport, Minneapolis, Minn.

PERSONNEL: J. E. Parker, Pres. & Gen. Mgr.; G. H. Plufka, V. Pres. & Treas.; R. W. Whittingham, Secy. & Prod. Mgr.; A. Molde, Pur. Dir.; D. H. Whitmore, Pers. Dir.; W. S. Stern, Pub. Dir.

**PRATT, READ & CO., INC.,**

Deep River, Conn.  
 PERSONNEL: J. A. Gould, Pres., Treas. & Gen. Mgr.; G. C. Seeley, V. Pres. & Secy.; P. H. Comstock, V. Pres. & Sales Mgr.; H. L. deForest, J. H. Gould, V. Pres.; H. E. Jopson, Prod. Mgr.; R. W. Stevens, Pur. Dir.; J. S. Dunn, Pers. Dir.; N. R. Gould, Pub. Dir.; J. W. Tumavicus, Chief Engr.

**ROBERTSON AIRCRAFT CORP.,**

Lambert St., Robertson, Mo.  
 PERSONNEL: N. Schuyler, Pres.; F. C. Webb, Secy. & Treas.; P. L. McMahon, Asst. Secy.; R. N. Rioux, Prod. Engr.; R. E. Laing, Pur. Agt.; H. W. Schrick, Pers. Dir.; E. Burd, Chief Engr.

**SPARTAN AIRCRAFT CO.,**

1900 N. Sheridan Rd., Tulsa, Okla.  
 PERSONNEL: J. P. Getty, Pres.; M. W. Balfour, V. Pres.; F. T. Hopp, Secy. & Treas.; G. F. Shortess, Contract Officer; J. Bredow, Pur. Dir.; A. Reitherman, Asst. Plant Mgr.; F. Stewart, Chief Engr.

**THE WACO AIRCRAFT CO.,** Troy, O.

PERSONNEL: C. J. Brukner, Pres.; H. R. Perry, V. Pres. & Gen. Mgr.; L. E. St. John, Secy.; R. E. Hoefflin, Treas.; J. Putterbaugh, Prod. Mgr.; F. E. Brower, Pur. Dir.; U. L. Moier, Pers. Dir.; C. J. Lake, Pub. Dir. & Adv. Mgr.; A. F. Arcier, Chief Engr.; R. Pearson, Factory Mgr.



**THE WACO AIRCRAFT CO.**

Troy, Ohio, U. S. A.

*Contractors to the U. S. Army Air Corps.*



DESIGNERS OF ALL ARMY  
CARGO-TRANSPORT GLIDERS

AIRCRAFT BUILDERS SINCE 1921

Designed by WACO and manufactured under WACO's engineering supervision are the gliders illustrated. From top to bottom: CG-3A, CG-4A, and CG-13.



**AIRCRAFT  
CONTROL  
WHEELS**

**Another famous  
ACE  
product for the  
aviation industry**



*Made by*

**AMERICAN HARD RUBBER COMPANY**

11 MERCER STREET, NEW YORK 13, N. Y.  
AKRON 4, OHIO

111 W. WASHINGTON ST., CHICAGO 5, ILL.

---



---

## MANUFACTURERS OF AIRCRAFT ENGINES

---



---

**AIRCOOLED MOTORS CORP.,**

Liverpool Rd., Syracuse, N. Y.

PERSONNEL: L. E. Pierson, Jr., Pres.; C. T. Doman, V. Pres. & Chief Engr.; C. F. B. Roth, V. Pres., Sales Mgr. & Pub. Dir.; C. F. Carr, Secy. & Treas.; J. E. Babcock, Prod. Mgr.; A. K. Stevens, Pur. Dir.; H. H. Severson, Pers. Dir.

**ALLISON DIV., GENERAL MOTORS CORP.,**  
Indianapolis, Ind.

PERSONNEL: F. C. Kroeger, Gen. Mgr.; H. L. Wilson, Asst. Gen. Mgr.; J. D. Welch, Asst. Corp. Secy.; H. F. Wilson, Asst. Corp. Treas.; W. G. Guthrie, Works Mgr.; O. T. Kreusser, Dir. Serv. & Training; C. M. Jessup, Mgr. Materiel Proc.; R. G. Kremer, Pers. Dir.; R. M. Hazen, Chief Engr.

**ATLANTIC DIESEL CORP.,**

401 Codwise Ave., New Brunswick, N. J.

PERSONNEL: J. S. Johnson, Pres.; O. S. Cabot, V. Pres.; J. E. Pakenham, Prod. Mgr.; R. F. Sturgis, Sales Mgr.; F. Mather, Pur. Dir.; J. F. Rowe, Pers. Dir.; W. A. Johns, Chief Engr.

**BUICK MOTOR DIV.,** Flint, Mich.

PERSONNEL: H. H. Curtice, Pres., I. L. Wiles, Treas.; W. F. Hufstader, Sales Mgr.; L. A. Stewart, Pur. Agt.; R. F. Thalner, Pers. Dir.; F. Webb, Pub. Dir.; C. A. Chayne, Chief Engr.

**COMMONWEALTH AIRCRAFT, INC.,**

Fairfax Airport, Kansas City 17, Kans.

PERSONNEL: R. Voyes, Pres.; W. W. Moss, Secy.; J. E. Vigus, Asst. Treas.; J. Farkas, Gen. Mgr. & Factory Mgr.; R. I. Hale, Prod. Mgr.; G. S. Hancock, Jr., Sales Mgr.; M. M. Joffee, Pur. Dir.; M. Bezner, Pers. Dir.; C. E. Rowland, Chief Engr.

**CONTINENTAL MOTORS CORP.,**

12801 E. Jefferson Ave., Detroit, Mich.

PERSONNEL: C. J. Reese, Pres. & Gen. Mgr.; A. Wild, V. Pres.; B. F. Tobin, Jr., Secy.; H. W. Vandeven, Treas.; D. Hollowell, Sales Mgr.; M. Ramsey, Pur. Agt.; J. Baker, Pers. Dir.; J. Wierengo, Pub. Dir.; T. Jackson, Chief Engr.

**FORD MOTOR CO.,** Dearborn, Mich.

PERSONNEL: H. Ford, Pres.; H. Ford, II, V. Pres.; C. E. Sorensen, V. Pres. & Gen. Mgr.; B. J. Craig, V. Pres. & Treas.; H. L. Moekle, Secy.; H. H. Bennett, Pers. Dir.; J. W. Thompson, Adv. Mgr.; D. S. Roeder, Chief Engr.

**JACOBS AIRCRAFT ENGINE CO.,**

Pottstown, Pa.

PERSONNEL: J. A. Harris, III, Ch. of Board, C. J. Abbott, Pres.; J. S. Smith, V. Pres. & Secy.; A. R. Jacobs, V. Pres. & Dir. Engrg.; H. M. McFadgen, V. Pres. & Engrg. Mgr.; D. F. Turner, V. Pres.-Mfg.; H. B. Knerr, Treas.; A. R. Thomas, Dir. Pur.; C. E. Heitman, Pers. Mgr.; C. E. Mines, Chief Engr.

**KINNER MOTORS, INC.,**

635 W. Colorado Blvd., Glendale, Calif.

PERSONNEL: E. Herring, Pres.; G. Edquist, V. Pres. & Sales Mgr.; W. G. Milka, G. Brashears, V. Pres.; V. E. Semrau, Secy. & Treas.; M. E. Sears, Asst. Secy.; P. Coleson, Pur. Agt.; E. J. Sullivan, Pers. Dir.; V. W. Wagoner, Mgr. Mfg.; J. G. Kuhn, Chief Engr.

**LYCOMING DIV., THE AVIATION CORP.**

Williamsport, Pa.

PERSONNEL: V. Emanuel, Pres.; W. F. Wise, Exec. V. Pres.; I. J. Snader, V. Pres.-Mfg.; P. E. Garland, V. Pres.-Operations; W. K. Cooper, Gen. Sales Mgr.; R. M. Mabee, Asst. Treas.; C. O. Samuelson, Sales Mgr.; W. J. Starr, Pur. Agt.; J. J. McBride, Pers. Dir.; H. A. Hershfield, Jr., Dir. Pub. & Adv.; S. K. Hoffman, Chief Engr.; Hill & Knowlton, Dir. Pub. Rel.

**NASH-KELVINATOR CORP.,**

14250 Plymouth Rd., Detroit 32, Mich.

PERSONNEL: G. W. Mason, Pres.; H. G. Perkins, V. Pres.; H. J. Mellum, Secy.; G. V. Egan, Treas.; C. T. Lawson, Sales Mgr., Kelvinator Div.; L. F. Skutt, Sales Mgr., Nash Div.; B. P. Watkins, Pur. Dir.; H. G. Little, Dir. of Pub. Rel.; C. J. Coward, Adv. Mgr., Kelvinator Div.; N. Nyland, Adv. Mgr., Nash Div.; F. F. Kishline, Chief Engr.

**PACKARD MOTOR CAR CO., AIRCRAFT**

ENGINE DIVISION, 1580 Grand Blvd.,

Detroit, Mich.

PERSONNEL: G. T. Christopher, Pres.; J. H. Marks, V. Pres.; H. J. Ferry, Secy. & Treas.; E. T. Phillips, Prod. Mgr.; L. W. Slack, Sales Mgr.; J. R. Kappler, Pur. Dir.; C. E. Weiss, Pers. Dir.; H. W. Hitchcock, Pub. Dir. & Adv. Mgr.; J. G. Vincent, Chief Engr.

**PRATT & WHITNEY AIRCRAFT, DIV. OF**

UNITED AIRCRAFT CORP., 400 S.

Main St., E. Hartford 8, Conn.

PERSONNEL: H. M. Horner, Pres.; S. A. Stewart, C. J. McCarthy, V. Pres.; C. H. Chatfield, Secy.; C. L. Gault, Treas.; J. F. McCarthy, Controller; W. P. Gwinn, Acting Gen. Mgr.; N. V. Clements, Adv. Mgr. & Pub. Dir.; T. E. Tillinghast, Sales Mgr.; J. J. Borrup, Prod. Mgr.; J. W. Dunnell, Pur. Mgr.; T. R. Downs, Pers. Supervisor; N. Benham, Pub. Rep.; A. V. D. Willgoos, Chief Engr.

**PRATT & WHITNEY AIRCRAFT CORP. OF**

MISSOURI, 907 Federal Reserve Bank

Bldg., Kansas City, Mo.

PERSONNEL: F. B. Rentschler, Ch.; E. E. Wilson, Pres.; J. F. McCarthy, Controller; R. Walsh, H. M. Horner, J. R. Miller, V. Pres.; F. E. Burnham, Gen. Acct.; C. H. Chatfield, Secy.; C. L. Gault, Treas.; F. G. Dawson, Gen. Mgr.; F. Detweiler, Div. Acct.; H. R. Barre, Pur. Agt.; J. Toher, Pers. Dir.; A. E. Smith, Chief Engr.

**RANGER AIRCRAFT ENGINES DIV. OF**

FAIRCHILD ENGINE & AIRPLANE

CORP., Farmingdale, N. Y.

PERSONNEL: H. H. Budds, V. Pres. & Gen. Mgr.; H. Van Gerbig, Asst. Gen. Mgr.; E. M. Lester, Asst. Gen. Mgr. & Dir. Contracts; C. F. Griemsmann, Compt.; C. O. Samuelson, Contracts Mgr.; P. E. Battilana, Sales & Service Mgr.; J. G. Ayers, Mgr., Plant 1; O. L. Saunder, Mgr., Plant 2; F. D. Hubbard, Dir. Pur.; H. S. Hall, Dir. Ind. Rel.; H. A. Hershfield, Jr., Dir. Pub. Rel.; R. B. Miller, Proc. Dir.; A. T. Gregory, Chief Engr.

**THE STUDEBAKER CORP.,**

635 S. Main St., South Bend, Ind.

PERSONNEL: P. G. Hoffman, Pres.; G. D. Keller, C. K. Whittaker, V. Pres.; K. B. Elliott, V. Pres.-Sales; R. A. Vail, V. Pres.-Mfg.; R. E. Cole, V. Pres.-Engrg.; A. G. Rumpf, Secy. & Treas.; P. O. Peterson, Dir. Pur.; G. E. Marque, Dir. Pub. Rel.; W. S. James, Chief Engr.

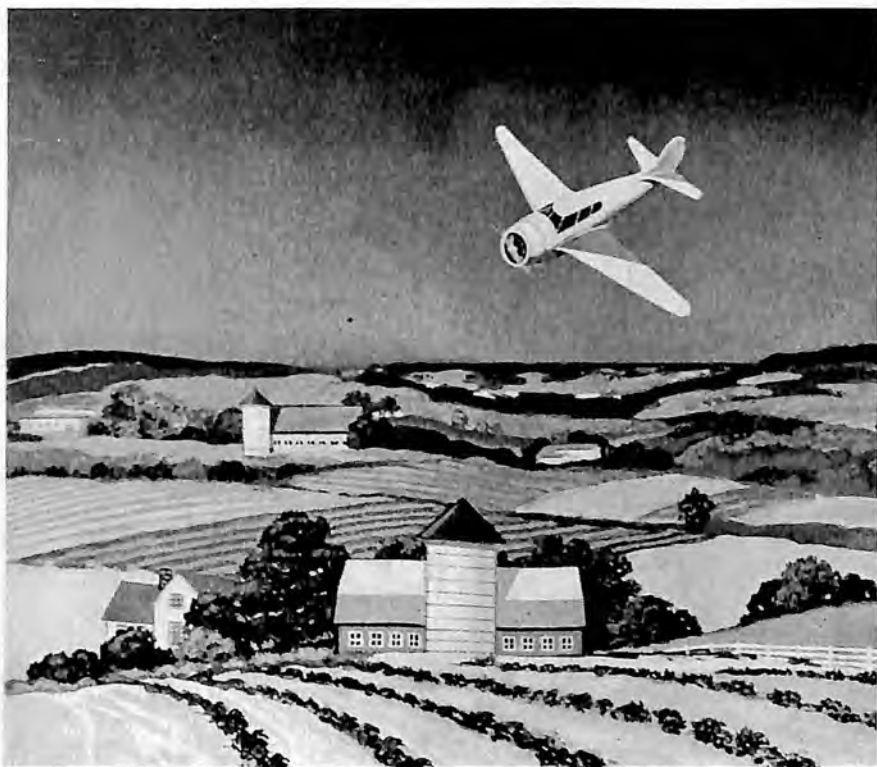

# HOME

## *Straight as an Arrow...*

With the unconditional surrender of our enemies,—which must be won by our blood, sweat and toil—, will come peace and the post-war period of reconstruction and development.

Aviation, now the No. 1 industry of America, will continue to lead the way. From the centers of our great cities to the vast expanses of our rural sections, Airplanes will play a leading part in our lives. Distances between home and place of business will be of much less importance, as the speed and efficiency of Aircraft will make commuting practical and economical. You can go home straight as an arrow, from wherever you are.

Advanced engineering and foresight will continue Jacobs leadership in the production of dependable and economical Aircraft Engines—*practical engines* for the private owner, the business concern and the "feeder" Airline.

**JACOBS** AIRCRAFT  
*Engines*
  
 POTTSTOWN • PENNSYLVANIA U • S • A •



Huge power plants for B-24 Liberator bombers, moving toward completion on the Rohr production line.

Starting with sleek Pratt & Whitney Motors, Rohr Production Fighters perform 5000 separate manufacturing, assembling and servicing operations in building up these motor nacelles, complete even to camouflage!

Each operation is a step on the road to Berlin, done with a precision that contributes to the on-time, over-target arrival of devastating bomb loads.

HELPING TO WRITE THE  
STORY OF TOMORROW



**ROHR**  
AIRCRAFT  
CORPORATION

CHULA VISTA, CALIFORNIA

# Historic Events of 1943

During the past year, Army-Navy-Industry cooperation accomplished miracles in aircraft development and production. The log of United Aircraft Corporation shows four events of especial significance:

**July 2.** Sikorsky Aircraft delivers the first of a quantity order for Sikorsky helicopters to the United States Army Air Forces.

**September 21.** Pratt & Whitney Aircraft delivers its 100,000th radial air-cooled engine, passing the hundred-million mark in production of dependable horsepower.

**December 21.** Hamilton Standard Propellers delivers its millionth blade.

**December 30.** Chance Vought Aircraft rolls its 2,000th F4U Corsair fighter off the line.

## UNITED AIRCRAFT CORPORATION

East Hartford • Connecticut

PRATT & WHITNEY  
ENGINES

CHANCE VOUGHT  
AIRPLANES

SIKORSKY  
HELICOPTERS

HAMILTON STANDARD  
PROPELLERS



**WARNER AIRCRAFT CORP.,**  
 20263 Hoover Ave., Detroit, Mich.  
**PERSONNEL:** W. O. Warner, Pres. & Gen. Mgr.;  
 L. A. Faunce, V. Pres., Sales Mgr. & Pub. Dir.;  
 W. J. Jarvie, Secy. & Treas.; R. F. Irwin, Pur.  
 Agt.; L. Gendernalik, Pers. Dir.; L. A. Majneri,  
 Chief Engr.

**WRIGHT AERONAUTICAL CORP., DIV.**  
**OF CURTISS-WRIGHT CORP.,** 132  
 Beckwith Ave., Paterson, N. J.  
**PERSONNEL:** G. W. Vaughan, Ch. of Board &  
 Pres.; M. B. Gordon, V. Pres. & Gen. Mgr.;  
 P. B. Taylor, V. Pres. & Asst. Gen. Mgr.; W. D.  
 Kennedy, V. Pres. & Mgr., Cincinnati, O.,  
 Plant; A. Nutt, V. Pres.-Engrg.; E. S. Cramer,  
 Secy.; C. C. King, Treas.; B. Adams, Sales  
 Mgr.; J. C. Stock, Controller; C. C. Shellborg,  
 Dir. Pur.; R. S. Husted, Mgr., Pub. Rel.;  
 W. J. Ehlers, Dir. Ind. Rel.; P. W. Brown, Dir.  
 Mfg.; J. M. Demarest, Mgr., Paterson Plant;  
 K. E. Sutton, Mgr., Wood-Ridge Plant.



**ENGINE COOLING  
 RADIATORS**



**OIL COOLERS**



**The G&O Manufacturing Co.**

**NEW HAVEN, CONNECTICUT**

Simmonds-Hobson  
**AUTOMATIC ENGINE CONTROLS**

**PUSH-PULL CONTROLS**

**HYDRAULIC ACCUMULATORS**

**HYDRAULIC FUSE**

**CHRONOMETRIC RADIOSONDES**

**SPARK PLUGS**

**SELF-ALIGNING ROD-END BEARINGS**

**COWLING AND PANEL CLIPS  
 AND FASTENERS**

**SIMMONDS**  
**AEROCESSORIES INC.**

**10 ROCKEFELLER PLAZA, NEW YORK, N. Y**

# THE Aeroproducts PROPELLER

**LIGHTNESS AND SIMPLICITY**

**In a Dependable Selective  
Constant Speed Propeller**

**T**HE Aeroproducts hydraulically operated constant speed propeller combines accurate, selective constant speed control with lightness, dependability, and simplicity of design.

Its entirely self-contained construction permits the use of an independent operating medium suitable for use under all extreme operating conditions. Installation and maintenance are greatly simplified by the compact, unit construction.

*For further information write  
Chief Engineer*

## AEROPRODUCTS DIVISION

**GENERAL MOTORS  
CORPORATION**

Dayton, Ohio



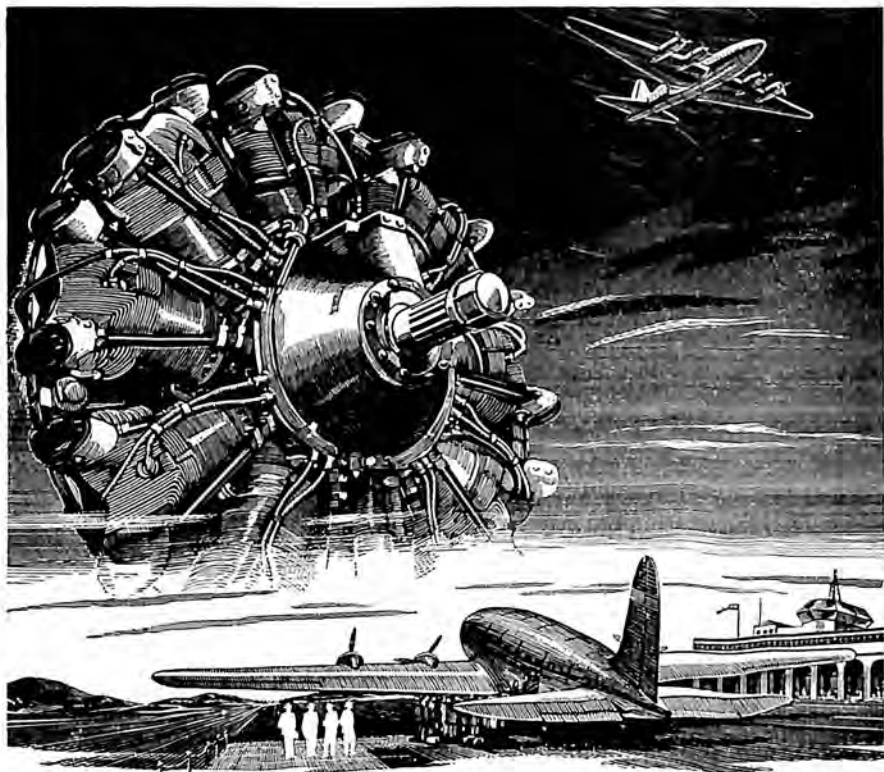

### The Extra Passenger in a Cyclone Engine

Power per pound is the general criterion for aircraft engine valuation. Take-off power, size, life, reliability and altitude performance are important criteria but other things being equal there is no substitute for "less weight." In Cyclone 9-powered planes the weight saving equals an extra passenger per engine.

Ten years ago, the Cyclone 9 weighed 1.2 pounds per horsepower. Since then, 600 HP has been added at a cost of only 420 lbs. in materials, cutting the weight ratio to .97 pounds per horsepower.

The Dynamic Damper, for example, added 20 pounds weight but permitted

an initial increase of 100 horsepower and opened the way to the present high ratings. Tripling its fin area, the Cyclone cylinder now produces 150 horsepower in the same cubic displacement which developed only 83 horsepower in 1933.

Thus Wright engineers have steadily extracted more and more power for smaller expenditures of material, so that today's Cyclone 9 is 13.5% lighter than any other engine in the same power class. This 13.5% means 175 lbs. advantage—or one passenger per engine—a payload bonus creating revenue dollars for the commercial operator.

*Wright Cyclones pay their way.*

*Cyclones and Whirlwinds · Light · Compact · Powerful*

**WRIGHT** Aircraft Engines

WRIGHT POWERS THE TONNAGE OF THE AIR



*Final inspection of aluminum pistons for Wright Cyclone aircraft engines. EXACT WEIGHT Scales handle this particular operation in one of America's leading motor car plants.*

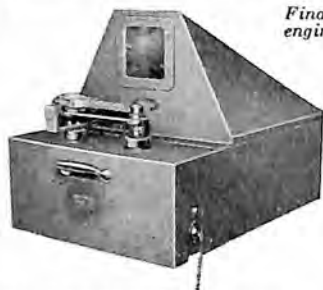

SHADOWGRAPH, an electrically operated weighing unit of high accuracy for connecting rod balancing and selection.



SHADOWGRAPH, Type A, an electrically operated scale for piston selection and precision.

## **EXACTNESS Rules in American Aircraft . .**

At the end of 1943 twelve of the eighteen world's leading aircraft in both military and civil categories are American. This is no accident. Rather it is the combination of adequate raw materials, skill and precision equipment, of which the latter plays a tremendous part. In engine manufacture especially precision measuring instruments incorporating the weighing principle is paramount. These operations include connecting rod balancing, final piston inspection, small parts counting and oil tests. Many different models of EXACT WEIGHT Scales do these precision tasks throughout the entire industry. Write for details covering your particular specifications.

**THE EXACT WEIGHT SCALE CO.**

**557 W. Fifth Ave., Columbus 8, Ohio**

**Dept. X, 1104 Bay St., Toronto, Canada**

*Exact Weight Scales*

# CLASSIFIED DIRECTORY OF EQUIPMENT MANUFACTURERS

## ABRASIVES

E. C. Atkins & Co.  
Campbell Hdwe. & Supply Co.  
Continental Machines Inc.  
Gardner Machine Co.  
General Abrasive Co. Inc.  
General Aircraft Supply Corp.  
Industrial Abrasives, Inc.  
Lasalco Inc.  
Mall Tool Co.  
Pangborn Corp.  
James H. Rhodes & Co.  
Frederic B. Stevens, Inc.

## AIR COMPRESSORS

Allis Chalmers Mfg. Co.  
Brunner Manufacturing Co.  
Champion Pneumatic Machinery Co.  
Curtis Pneumatic Machinery Div. of  
Curtis Machinery Co.  
The De Vilbiss Co.  
Dix Manufacturing Co.  
The Ohio Piston Co.  
Paasche Airbrush Co.  
Ritter Co., Inc.  
Sutorbilt Corp.

## AIRCRAFT ARMAMENT

Aeronautical Mfg. Corp.  
Air Associates, Inc.  
American Armament Corp.  
Aviquito Manufacturing Corp.  
Bendix Products Div. of Bendix Avia-  
tion Corp.  
Breeze Corporations, Inc.  
Diebold, Inc.  
Harvey Machine Co., Inc.  
Hayes Manufacturing Corp.  
Moore-Eastwood & Co.  
National Machine Products  
New-Bart Stamping & Mfg. Co.  
New Brunswick Die Molding Div. of  
Universal Plastics Corp.  
Perry Metal Products Co. Inc.  
Plastic Manufacturers, Inc.

Pollak Manufacturing Co.  
Sperry Gyroscope Co., Inc.  
Spriesch Tool & Mfg. Co., Inc.  
Warner Manufacturing Co.

## AIRPORT EQUIPMENT

The Adams & Westlake Co.  
Aero Tool Co.  
Air Associates, Inc.  
Airplane Manufacturing & Supply  
Corp.  
Allis-Chalmers Mfg. Co.  
American Foundry & Furnace Co.  
American Gas Accumulator Co.  
Anchor Post Fence Co.  
Arch Roof Construction Co., Inc.  
The Automatic Vise Sales Co.  
Baldor Electric Co.  
Bendix Aviation Corp., Pacific Div.  
Communications Co., Inc.  
Crescent Truck Co.  
Crouse-Hinds Co.  
Dahlstrom Metallic Door Co.  
The Denison Engineering Co.  
Dix Manufacturing Co.  
Friez Instrument, Div. of Bendix  
Aviation Corp.  
Gilbert & Barker Mfg. Co.  
Ilg Electric Ventilating Co.  
Independent Pneumatic Tool Co.  
Liberty Motors & Engineering Corp.  
Lyon-Raymond Corp.  
Malabar Machine Co.  
Manbee Equipment Co.  
The Mercury Manufacturing Co.  
Pacific Engineering Corp.  
Permoflux Corp.  
Perry Metal Products Co. Inc.  
Pioneer Engineering Works, Inc.  
The Pyle-National Co.  
Radio Receptor Co. Inc.  
Rohr Aircraft Corp.  
St. Louis Radio Engineering Co.  
Standard Aircraft Products, Inc.  
M. C. Stewart  
Trans-American Airports Corp.  
Veeder-Root Inc.

# BREEZE CORPORATIONS, INC.

**Manufacturers of Highest Quality Aircraft Parts and Products For Commerce and Defense**

★ REGULAR CONTRACTORS TO U. S. GOVERNMENT ★

Radio Ignition and Auxiliary Shielding • Multiple Circuit Electrical Connectors • Flexible Shielding Conduit and Fittings • Conduit Junction Boxes.

Cartridge Engine Starters • Dichromate Cartridge Containers • Internal Tie Rods • Propeller Pitch Controls • Elevator and Rudder Tab Controls.

Flexible Shaft and Case Assemblies • Aeroflex Jr. Flexible Instrument Lines.



Tachometer, Fuel Pump and Remote Control Drives • Ammunition Rounds Counters • Radio Tuning Units.

Generator and Ignition Filters • Exhaust Gas Analyzers (Fuel-Air Ratio Indicators) • Flexible Metal Tubing • Resistance Type Thermometers • Swaging Machines and Tools • Armor Plate.

Stainless Steel Division: Pioneers in the design and development of stainless steel structures and fabricated products.

*Breeze*

**CORPORATIONS, INC.**  
NEWARK, NEW JERSEY



**(Airport Equipment) Continued**

Warner Manufacturing Co.  
Westinghouse Electric & Manufacturing Co.

**AMMUNITION BOXES  
& COUNTERS**

Air-Craft Equip. Div. of Anchor Post Fence Co.  
Aircraft Components, Inc.  
American Armament Corp.  
American Stamping & Mfg. Co.  
Associated Foundries & Manufacturers, Inc.  
Automatic Electrical Devices Co.  
Baltic Metal Products Co.  
Bendix Aviation Corp., Pacific Div.  
Chas. W. Carll Sons  
Harvey Machine Co., Inc.  
Hayes Manufacturing Corp.  
Kenyon Instrument Co., Inc.  
Kilgen Aircraft, Div. The Kilgen Organ Co.  
King Plastics Corp.  
McQuay, Inc.  
New-Bart Stamping & Mfg. Co.  
Perry Metal Products Co. Inc.  
Pollak Manufacturing Co.  
Geo. D. Roper Corp.  
Samson United Corp.  
Technical Ply-Woods  
Veeder-Root Inc.  
Weber Showcase & Fixture Co., Inc.

**AUXILIARY POWER  
PLANTS**

Andover Motors Corp.  
Automatic Electrical Devices Co.  
Bardco Manufacturing & Sales Co.  
Eclipse-Pioneer Div., Bendix Aviation Corp.  
Kiekhaefer Corp.  
Lasalco Inc.  
Lawrance Aeronautical Corp.  
Menaugh-Dutterer Co.  
D. W. Onan & Sons  
Waukesha Motor Co.

**BASIC MATERIALS  
& FABRICATIONS**

Aero Supply Mfg. Co. Inc.  
Air Associates, Inc.  
Allegheny Ludlum Steel Co.

American Magnesium Corp.  
Arnolt Motor Co.  
Automatic Electrical Devices Co.  
Chas. W. Carll Sons  
The Carpenter Steel Co.  
The Formica Insulation Co.  
Handy & Harman  
Harris Seybold Potter Co., Seybold Div.  
Jowein Inc. Aircraft Div.  
King Plastics Corp.  
Perry Metal Products Co. Inc.  
Pittsburgh Steel Co.  
Revere Copper & Brass Inc.  
Rohr Aircraft Corp.  
Scott Aviation Corp.  
Spaulding Fibre Co., Inc.  
W. Harris Thurston—Thurston Cutting Corp.  
Trans-American Airports Corp.  
Warner Manufacturing Co.  
Weber Showcase & Fixture Co., Inc.  
H. A. Wilson Co.

**BATTERIES**

Aeronautical Radio Mfg. Co.  
Aircraft Instrument Service, Inc.  
Burgess Battery Co.  
Delco-Remy Div., General Motors Corp.  
The Electric Auto-Lite Co.  
General Aircraft Supply Corp.  
Gould Storage Battery Corp.  
Ideal Commutator Dresser Co.  
Ray-O Vac Co.  
Standard Electric Co., Inc.  
Trans-American Airports Corp.  
United States Rubber Co.

**BEARINGS**

Acorn Bearing Co.  
Angelus Steel Treating Co.  
Bantam Bearings Corp.  
The Cleveland Graphite Bronze Co.  
The Fafnir Bearing Co.  
Keystone Carbon Co., Inc.  
Link-Belt Co.  
McQuay-Norris Manufacturing Co.  
P. R. Mallory & Co., Inc.  
Marlin-Rockwell Corp.  
Miniature Precision Bearings  
New Departure Div. General Motors Corp.  
Norma-Hoffmann Bearings Corp.

# AUTO-LITE Spark Plugs *for* AIRCRAFT



**NEW TYPE CERAMIC**  
GIVES MECHANICAL STRENGTH IN  
COMPRESSION GREATER THAN  
STEEL—HARDNESS APPROACHING  
DIAMONDS—HIGHLY RESISTANT TO  
THERMAL SHOCK!

Auto-Lite's new type ceramic spark plugs are built to stand up under conditions modern aircraft have to meet—arctic cold, tropical heat, bombing dives from stratosphere to sea level . . . Painsstaking laboratory development and tests have made possible an aircraft plug with many advantages. At present earmarked for Army and Navy use they will contribute to America's peacetime leadership on the airways of the world.

**THE ELECTRIC AUTO-LITE COMPANY**  
SARNIA, ONT. TOLEDO, 1, OHIO



TUNE IN "EVERYTHING FOR THE BOYS" STARRING RONALD COLMAN—TUESDAY NIGHTS—NBC NETWORK

**(Bearings) Continued**

SKF Industries, Inc.  
 Simmonds Aerocessories, Inc.  
 Special Machine Tool Engineering  
 Works  
 The Timken Roller Bearing Co.  
 Trans-American Airports Corp.  
 United Aircraft Products, Inc.  
 N. A. Woodworth Co.

**Ball**

The Fafnir Bearing Co.  
 Jack & Heintz, Inc.  
 Link-Belt Co.  
 Marlin-Rockwell Corp.  
 Miniature Precision Bearings  
 New Departure Div. General Motors  
 Corp.  
 Norma-Hoffmann Bearings Corp.

**Roller**

General Armature Corp.  
 Link-Belt Co.  
 Marlin-Rockwell Corp.  
 Norma-Hoffmann Bearings Corp.  
 Roller Bearing Co. of America  
 The Timken Roller Bearing Co.

**Sleeve**

A C Spark Plug Div., General Motors  
 Corp.  
 The American Auto Parts Co.  
 Barium Metals Corp.  
 The Cleveland Graphite Bronze Co.  
 Keystone Carbon Co., Inc.  
 McQuay-Norris Manufacturing Co.  
 P. R. Mallory & Co., Inc.  
 Perry Metal Products Co. Inc.  
 Phillips Bronze Corp.  
 Special Machine Tool Engineering  
 Works  
 N. A. Woodworth Co.

**BOMB RACKS**

Aero Parts Manufacturing Co.  
 All American Aircraft Products, Inc.  
 American Central Manufacturing  
 Corp.  
 American Stamping & Mfg. Co.  
 Baltic Metal Products Co.  
 Chas. W. Carll Sons  
 Harvey Machine Co., Inc.

Hayes Manufacturing Corp.  
 Liberty Aircraft Products Corp.  
 Moore-Eastwood & Co.  
 National Machine Products  
 Pacific Aviation, Inc.  
 Perry Metal Products Co. Inc.  
 Pollak Manufacturing Co.  
 Rohr Aircraft Corp.  
 Spriesch Tool & Mfg. Co., Inc.  
 Weber Showcase & Fixture Co., Inc.  
 Westinghouse Electric & Manufactur-  
 ing Co.

**BRAKES & PARTS**

Adel Precision Products Corp.  
 Barrett Equipment Co.  
 Bendix Products Div. of Bendix  
 Aviation Corp.  
 Firestone Aircraft Co.  
 General Aircraft Supply Corp.  
 The B. F. Goodrich Co.  
 Goodyear Aircraft Corp.  
 Hayes Industries, Inc.  
 Hoof Products Co.  
 Irvington Varnish & Insulator Co.  
 Johns-Manville Sales Corp.  
 Pacific Aviation, Inc.  
 Perry Metal Products Co. Inc.  
 Scott Aviation Corp.  
 Trans-American Airports Corp.  
 Verson Allsteel Press Co.  
 The Weatherhead Co.

**BUSHINGS**

Aeronautical Mfg. Corp.  
 Airco Tool Co.  
 Aircraft & Marine Specialty Co.  
 Aircraft Products Co.  
 Aircraft Screw Products Co., Inc.  
 The American Auto Parts Co.  
 American Screw Products  
 Angelus Steel Treating Co.  
 Arnolt Motor Co.  
 Associated Foundries & Manufac-  
 turers, Inc.  
 Associated Rubber Products Co.  
 Atlantic India Rubber Works, Inc.  
 Barium Metals Corp.  
 The Bowling Green Rubber Co.  
 Campbell Hdwe. & Supply Co.  
 Chase Brass & Copper Co.  
 The Cleveland Graphite Bronze Co.  
 Firestone Aircraft Co.  
 The B. F. Goodrich Co.

# LIBERTY

## AIRCRAFT PRODUCTS

*Precision*—Geared to the Nation's war effort this organization with its modernly equipped plant is "all out" in the production drive. We are ready on request to talk over your production problems.

Precision machine parts—tools—production machine parts to order—screw machine products—milling and gear cutting work—engine cylinders, pistons, crankcases—heat treating and carburizing in electric furnaces with atmospheric control—cadmium plating and hard chrome plating—

anodizing aluminum alloy parts — aircraft sheet metal work — wing assemblies—tail surfaces — pontoons — bomb racks — complete aircraft doping and finishing work.

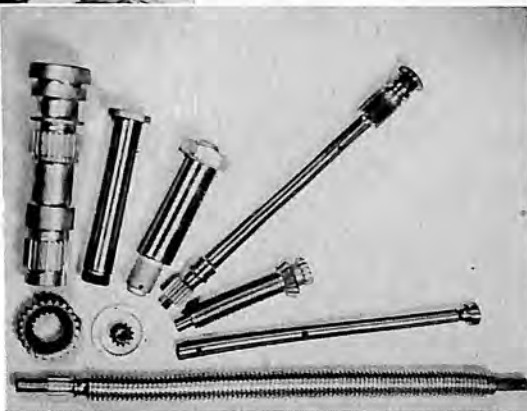

**Robert Simon**  
*President*

**George H. Hauser**  
*Vice President*

**William G. Holman**  
*Secretary-Treasurer*

**William Ochse**  
*Machine Shop Superintendent*

**Elmer Matzen**  
*Purchasing Agent*

**LIBERTY AIRCRAFT PRODUCTS CORP.**

*Manufacturers of Aircraft Parts*

FARMINGDALE

LONG ISLAND

NEW YORK

**(Bushings) Continued**

Harris Products Co.  
Keystone Carbon Co., Inc.  
P. R. Mallory & Co., Inc.  
Metal Carbides Corp.  
Otto Aviation Corp.  
Perry Metal Products Co. Inc.  
Phillips Bronze Corp.  
Products Engineering Co.  
Rohr Aircraft Corp.  
Spaulding Fibre Co., Inc.  
Thompson Products, Inc.  
Trans-American Airports Corp.  
United States Rubber Co.  
N. A. Woodworth Co.

**CABIN HARDWARE  
& FURNISHINGS**

The Adams & Westlake Co.  
General Aircraft Supply Corp.  
Highbridge-International Co.  
King Plastics Corp.  
Otto Aviation Corp.  
Perry Metal Products Co. Inc.  
Snapvent Co.  
Trans-American Airports Corp.  
Veeder-Root Inc.

**CAMERAS &  
SUPPLIES**

Abrams Instrument Co.  
Adel Precision Products Corp.  
Bell & Howell Co.  
Chicago Aerial Survey Co.  
De Jur-Amsco Corp.  
Dix Manufacturing Co.  
Eastman Kodak Co.  
The Folmer Graflex Corp.  
L. M. Gear Co.  
H. K. Lorentzen, Inc.  
St. Louis Radio Engineering Co.  
Special Machine Tool Engineering  
Works

**CARBURETORS**

Bendix Products Div. of Bendix  
Aviation Corp.  
Chandler-Evans Corp.  
Clifford Manufacturing Co.  
Holley Carburetor Co.  
Major Aircraft Foundry  
Newark Wire Cloth Co.  
Trans-American Airports Corp.

**CASTINGS**

A & F Aluminum Products Co.  
Acme Pattern & Tool Co., Inc.  
Advance Aluminum Castings Corp.  
Aero Supply Mfg. Co. Inc.  
Alloys Foundry Inc.  
Alpha Metals, Inc.  
Aluminum Company of America  
Aluminum Industries, Inc.  
American Chain & Cable Co., Inc.  
American Foundry & Furnace Co.  
American Magnesium Corp.  
Ampco Metal, Inc.  
Angelus Steel Treating Co.  
Arrow Brass Foundry  
Bardco Manufacturing & Sales Co.  
Barium Metals Corp.  
Bethlehem Steel Co.  
Chase Brass & Copper Co.  
Columbia Steel Co.  
Delco-Remy Div., General Motors  
Corp.  
Eclipse-Pioneer Div., Bendix Avia-  
tion Corp.  
The Electric Auto-Lite Co.  
Frontier Bronze Corp.  
General Bronze Corp.  
Harvey Machine Co., Inc.  
Liberty Motors & Engineering Corp.  
Link-Belt Co.  
Major Aircraft Foundry  
Muskegon Piston Ring Co.  
The Newton-New Haven Co.  
Ohlsson & Rice Manufacturing Co.  
The Permold Co.  
Perry Metal Products Co. Inc.  
Phillips Bronze Corp.  
Geo. D. Roper Corp.  
Scott Aviation Corp.  
Veeder Root Inc.  
Warner Manufacturing Co.  
The Wellman Bronze & Aluminum  
Co.

**CLAMPS**

Adel Precision Products Corp.  
Adjustable Clamp Co.  
Aero Trades Co.  
Aircraft Products, Inc.  
American Phenolic Corp.  
Armstrong Bros. Tool Co.  
The M. B. Austin Co.  
Automotive Rubber Co.  
B. H. Aircraft Co.



**THOMPSON PRODUCTS, INC.**

manufactures over 1000 aircraft engine and airplane parts in approximately 70 different classifications, including valves, valve seat inserts, valve keys, tappets, fuel pumps, propeller parts, retractable strut assemblies and landing gear assemblies.



**Thompson Products**  
 CLEVELAND • DETROIT • LOS ANGELES



**(Clamps) Continued**

The Bassick Co.  
 The Brewer-Titchener Corp.  
 The Cleveland Pneumatic Tool Co.  
 Colgate Aircraft Corp.  
 Commercial Plastics Co.  
 Detroit Stamping Co.  
 General Aircraft Supply Corp.  
 Heyman Mfg. Co.  
 Hyland Machine Co.  
 Keystone Aircraft Products, Inc.  
 Knu-Vise, Inc.  
 Monogram Manufacturing Co.  
 Onsrud Machine Works, Inc.  
 Perry Metal Products Co. Inc.  
 Pollak Manufacturing Co.  
 Products Engineering Co.  
 Solar Aircraft Co.  
 Trans-American Airports Corp.  
 United-Carr Fastener Corp.

**CLEANERS &  
 CLEANING  
 COMPOUNDS**

Acme White Lead & Color Works  
 Aircraft Specialties Co.  
 American Air Filter Co., Inc.  
 American Chemical Paint Co.  
 American Foundry Equipment Co.  
 Automatic Electrical Devices Co.  
 Babbitt Industrial Specialties Co.  
 The Bell Co., Inc.  
 Bendix Products Div. of Bendix Aviation Corp.  
 Breuer Electric Mfg. Co.  
 Circo Products Co.  
 Commercial Chemical Co.  
 The Cowles Detergent Co.  
 Detrex Corp.  
 Fischer Industries, Inc.  
 General Aircraft Supply Corp.  
 E. F. Houghton & Co.  
 Lasalco Inc.  
 Oakite Products, Inc.  
 Pangborn Corp.  
 Pennsylvania Salt Manufacturing Co.  
 Petroleum Solvents Corp.  
 Phillips Manufacturing Co.  
 The Phoenix Oil Co.  
 Radiator Specialty Co.  
 Standard Oil Co. of California  
 Frederic B. Stevens, Inc.  
 Sutorbilt Corp.  
 Trans-American Airports Corp.  
 Wayne Chemical Products Co.  
 Wyandotte Chemicals Corp.

**Buffing, Burring  
 & Polishing**

Chicago Wheel & Mfg. Co.  
 Lea Manufacturing Co.

**CLOTHING &  
 EQUIPMENT**

Air Associates, Inc.  
 S. Appel & Co., Inc.  
 General Aircraft Supply Corp.  
 General Electric Co.  
 United States Rubber Co.

**COLLECTOR RINGS**

Aero Parts Manufacturing Co.  
 Aircraft Components, Inc.  
 Aircraft Products, Inc.  
 American Central Manufacturing Corp.  
 American Stamping & Mfg. Co.  
 American Tube Bending Co., Inc.  
 B. H. Aircraft Co.  
 Duramold Div. of Fairchild Engine & Airplane Corp.  
 Guiberson Diesel Engine Co.  
 Hockaday Aircraft Corp.  
 P. R. Mallory & Co., Inc.  
 Perry Metal Products Co. Inc.  
 Plastic Manufacturers, Inc.  
 Pollak Manufacturing Co.  
 Samson United Corp.  
 Solar Aircraft Co.  
 Special Machine Tool Engineering Works  
 Trans-American Airports Corp.  
 Tyler Fixture Corp.  
 Westinghouse Electric & Manufacturing Co.

**CONSTRUCTION**

Independent Iron Works, Ltd.  
 Marine-Air Research Corp.  
 Maryland Metal Building Co., Inc.  
 Pittsburgh Steel Co.  
 Republic Steel Corp.  
 Revere Copper & Brass Inc.

**CONTROLS**

Abrams Instrument Co.  
 Aero Parts Manufacturing Co.  
 Aero Trades Co.



**Clean with DEOXIDINE Before Alrok\* Finishing**

To insure a uniform corrosion resistant surface. It has recently been established that both effectiveness and appearance of the Alrok finish is much improved by Deoxidine cleaning before treating.

Aluminum and aluminum alloys are made chemically clean when given the Deoxidine bath which enables Alrok to develop a more

\* Reg. T. M. Aluminum Co. of America.

uniform protective finish than when surfaces are cleaned with the alkali solutions formerly used.

Deoxidine is equally efficient for cleaning all metals (except zinc or cadmium). There are various grades of Deoxidine adapted to the various methods of application and different conditions of surfaces.

*Manufacturers of Inhibitors & Metal Working Chemicals*

**AMERICAN ACP PAINT CO.**

Note — West Coast Plants may address inquiries and orders for prompt delivery to Leon Finch, Ltd., 728 East 59th St., Los Angeles, California.

**AEROLS**

These shock absorbing landing gear units insure safe, smooth landings and take-offs. Used on trainers, fighters, bombers and transport planes.

**CLECO TOOLS**

Hundreds of sizes and styles to speed aircraft fabrication. Riveters, drills, sheet holders, squeezers, screw drivers, nut setters, etc.—the right tool for every job.

**The Cleveland  
Pneumatic Tool Co.**

Cleveland 5, Ohio

Correct Uniforms Since 1856



**OFFICERS UNIFORMS**  
*for all*  
**AIR TRANSPORT**  
*Services*



NEW YORK, N. Y. and MIAMI, FLA.  
18 Fulton St. 323 N.E. 1st St.



## SELENIUM AND COPPER SULPHIDE RECTIFIERS PLATES AND STACKS

*Rectifier Transformer Assemblies, incl.*

- Aircraft Power Rectifiers
- DC Power Supplies for testing radio receivers and transmitters
- Conventional and Fast Chargers for 6, 12, and 24 volt batteries
- DC Power Supplies or Packs for practically any requirement or application

Check with B-L for any rectifier requirement.

*The* **BENWOOD LINZE Co.**  
1808 LOCUST ST. • ST. LOUIS, MO.

### Give Your Plating and Finishing Room Problems to a LASALCO ENGINEER

Here is a list of some of the equipment and supplies he has available to give you the RIGHT solution quickly. Immediate delivery on Lea Deburring Materials, MAC DERMID CLEANERS AND SOLVENTS.

Plating Barrels:	Hard Chrome Equip-	Tripoli	
Utility	ment	White Finish	
Bull's Eye	Anodizing Equipment	Chrome Composition	
Richards	Magnesium Treating	Emery Cake	
Burnishing Barrels	Equipment	Grease Stick	
Tumbling Barrels	Descaling Equipment	Stainless Steel Composi-	
Cushioned Belt Grinders	Blackening Process	tion	
Electric Sawdust Tum-	Special Plating Machines	Crocus	
blers	to meet any require-	Anodes:	
Full Automatic Ma-	ment	Nickel	Cadmium
chines	Bufs and Polishing	Copper	Lead
Semi-Automatic Machines	Wheels	Brass	Gold
		Zinc	Silver

### Complete Line of Chemicals and Supplies for Plating

Nickel Salts	Zin-O-Lyte Zinc Solution	Maizo Meal
Chromic Acid	DuPont Hi-Speed Copper	Copper Wire
Sodium Cyanide	Chandeysson Generators	Insulating Steam Joints
Copper Cyanide	GE Rectifiers	Rheostats
Zinc Cyanide, etc.	Dipping Baskets	Test Sets
Sangamo Amperehour	Scratch Brushes	Plating Racks
Meters	Scrub Brushes	Stop-Off Lacquers
Cadalyte Cadmium Solu-	Sawdust	Rack Lacquers
tion		

Write today for complete information—or ask a Lasalco Engineer to call.  
LASALCO, INC., 2818-38 LaSalle St., St. Louis, Mo.

Chandler-Evans  
 Makes This Efficient  
**FUEL PUMP**  
 for Airplanes, Tanks  
 and P T Boats



Study these parts carefully. Note the variations in size and shape. Note the contours, holes, recesses and slots. To finish such parts properly and economically calls for the right technique and materials which were worked out with the help of Lea Finishing Engineers. The management reports "most satisfactory results."

Of the thousands of different articles being finished by Lea Methods and Materials, none illustrates better the versatility and

usefulness of Lea Service than do these pump parts. The burring and finishing problems were not simple but every one was effectively solved.

Lea offers a two-fold service to industry and service stations: (1) skilled engineering assistance in working out burring, finishing or re-finishing methods, and (2) a great variety of greaseless and "no free grease" compositions, wheels and bobs with which to carry out the necessary steps.

THE **LEA** MANUFACTURING CO.  
 WATERBURY 86, CONN.

Burring, Buffing and Polishing . . . Manufacturers and Specialists in the Development of Production Methods and Compositions

**(Controls) Continued**

Aeronautical Mfg. Corp.  
 Air Associates, Inc.  
 Aircraft Products Co.  
 Airesearch Manufacturing Co.  
 All American Aircraft Products, Inc.  
 American Chain & Cable Co., Inc.  
 The Apex Machine & Tool Co.  
 Aviquipo Manufacturing Corp.  
 Barber-Colman Co.  
 The Bristol Co.  
 Eclipse-Pioneer Div., Bendix Aviation Corp.  
 Fenwal, Inc.  
 Foote Bros. Gear & Machine Corp.  
 General Aircraft Supply Corp.  
 General Controls Co.  
 General Electric Co.  
 Goodyear Aircraft Corp.  
 Hockaday Aircraft Corp.  
 Harvey Machine Co., Inc.  
 The Imperial Brass Manufacturing Co.  
 Kenyon Instrument Co., Inc.  
 Langley Corp.  
 Link-Belt Co.  
 Moore-Eastwood & Co.  
 Otto Aviation Corp.  
 Robertshaw Thermostat Co.  
 Simmonds Aerocessories, Inc.  
 Trans-American Airports Corp.  
 United Aircraft Products, Inc.  
 Westinghouse Electric & Manufacturing Co.  
 The S. S. White Dental Mfg. Co.  
 White-Rodgers Electric Co.

**Cables & Assemblies**

Aero Trades Co.  
 Aeronautical Radio Mfg. Co.  
 American Chain & Cable Co., Inc.  
 American Steel & Wire Co.  
 Arens Controls, Inc.  
 The E. W. Carpenter Mfg. Co.  
 Columbia Steel Co.  
 General Aircraft Supply Corp.  
 Gilfillan Bros. Inc.  
 The Imperial Brass Manufacturing Co.  
 I. Jacoel Cable Splicing Equipment Co.  
 Kenyon Instrument Co., Inc.  
 Kulka Electric Mfg. Co., Inc.  
 Otto Aviation Corp.  
 Perry Metal Products Co. Inc.

Rochester Ropes, Inc.  
 John A. Roebbling's Sons Co.  
 Rohr Aircraft Corp.  
 Samson United Corp.  
 Trans-American Airports Corp.

**Chains, Sprockets & Assemblies**

Baldwin Duckworth Div. of Chain Belt Co.  
 Kenyon Instrument Co., Inc.  
 Link-Belt Co.  
 Otto Aviation Corp.  
 Perry Metal Products Co. Inc.

**Pulleys**

Aviquipo Manufacturing Corp.  
 The Formica Insulation Co.  
 General Aircraft Supply Corp.  
 Gilfillan Bros. Inc.  
 Otto Aviation Corp.  
 Perry Metal Products Co. Inc.  
 Plastic Manufacturers, Inc.  
 Trans-American Airports Corp.  
 Warner Manufacturing Co.  
 Westinghouse Electric & Manufacturing Co.

**Sticks & Wheels**

Aero Trades Co.  
 Aircraft & Marine Specialty Co.  
 Aircraft Specialties Co.  
 All American Aircraft Products, Inc.  
 American Hard Rubber Co.  
 Firestone Aircraft Co.  
 Guardian Electric Mfg. Co.  
 Trans-American Airports Corp.

**COVERS**

The Adams & Westlake Co.  
 Aero Parts Manufacturing Co.  
 Burlington Mills, Inc.  
 Cluff Fabric Products  
 C. R. Daniels, Inc.  
 Firestone Aircraft Co.  
 Perry Metal Products Co. Inc.  
 Rohr Aircraft Corp.  
 Trans-American Airports Corp.  
 United States Rubber Co.

**COWLINGS**

Aero Parts Manufacturing Co., Inc.  
 Aero Trades Co.



Foote Bros. Precision Gears are used in Pratt and Whitney Airplane Engines



Foote Bros. Gears Transmit Power to PT Boats and Coast Guard Auxiliaries



On Listening Devices, Foote Bros. Speed Reducers Turn the Detectors



Tractors for Industrial and Farm Use Also Rely on Foote Bros. Gears

## THE WORLD TODAY *Turns on Gears...*

It takes gears to turn the propellers of our mighty air force—gears to operate tanks and artillery—gears to transmit the power in our PT boats and Coast Guard Auxiliaries—gears by the millions for an almost unlimited number of duties everywhere.

And making these gears is Foote Bros.' job, for today in four large plants, machines are humming, turning out gears in quantities that not many months ago were inconceivable. And a large percentage of these gears are of such extreme precision that their production by mass methods literally meant a new advance in gear manufacture.

The experience gained by Foote Bros.' engineers and Foote Bros.' workmen in making the impossible possible, promises a new approach to gear design and manufacture after the war.

Peacetime machines will find new economies in operation, new efficiencies in performance—thanks to high precision gears that today are being produced by Foote Bros. to meet the needs of war.

FOOTE BROS. GEAR & MACHINE CORPORATION  
5225 South Western Boulevard • Chicago 9, Illinois



# FOOTE BROS.

*Better Power Transmission Through Better Gears*



**(Cowlings) Continued**

Aircraft Components, Inc.  
 All American Aircraft Products, Inc.  
 American Central Manufacturing Corp.  
 B. H. Aircraft Co.  
 Burlington Mills, Inc.  
 Chas. W. Carll Sons  
 Edo Aircraft Corp.  
 G & H Tool & Manufacturing Co.  
 Guiberson Diesel Engine Co.  
 Harvey Machine Co., Inc.  
 Hayes Manufacturing Corp.  
 King Plastics Corp.  
 The Murray Corp. of America  
 Perry Metal Products Co. Inc.  
 Pollak Manufacturing Co.  
 Reynolds Metals Co.  
 Roberts & Mander Stove Co.  
 Rohr Aircraft Corp.  
 Solar Aircraft Co.  
 Taylorcraft Aviation Corp.  
 Trans-American Airports Corp.

**CYLINDER  
 DEFLECTORS,  
 BAFFLES, BRACKETS**

Aero Parts Manufacturing Co.  
 Aero Trades Co.  
 American Aluminum Ware Co.  
 Baltic Metal Products Co.  
 Colgate Aircraft Corp.  
 Guiberson Diesel Engine Co.  
 Perry Metal Products Co., Inc.  
 Pollak Manufacturing Co.  
 Reynolds Metals Co.  
 Rohr Aircraft Corp.  
 Samson United Corp.  
 Taylorcraft Aviation Corp.  
 Trans-American Airports Corp.

**DEHYDRATED  
 PACKING**

The Davison Chemical Corp.  
 The Permutit Co.

**DE-ICER EQUIPMENT**

Adel Precision Products Corp.  
 Air Associates, Inc.  
 Aircraft Components, Inc.  
 Aircraft Specialties Co.  
 The Aro Equipment Corp.

Automatic Electrical Devices Co.  
 The Bell Co., Inc.  
 Chandler-Evans Corp.  
 Cook Electric Co.  
 Drayer & Hanson, Inc.  
 Eclipse-Pioneer Div., Bendix Aviation Corp.  
 Firestone Aircraft Co.  
 General Controls Co.  
 The B. F. Goodrich Co.  
 Hayes Manufacturing Corp.  
 The Imperial Brass Manufacturing Co.  
 Kenyon Instrument Co., Inc.  
 McQuay, Inc.  
 The Marquette Metal Products Co.  
 Mercury Aircraft, Inc.  
 Mobile Refrigeration Div., Bowser, Inc.  
 Otto Aviation Corp.  
 The Parker Appliance Co.  
 Perry Metal Products Co. Inc.  
 Pesco Products Co.  
 Solar Aircraft Co.  
 Special Machine Tool Engineering Works  
 The Trane Co.  
 Trans-American Airports Corp.  
 United States Rubber Co.  
 Warner Manufacturing Co.  
 White-Rodgers Electric Co.

**ELECTRICAL  
 EQUIPMENT**

Ace Manufacturing Corp.  
 Adel Precision Products Corp.  
 Aero Supply Mfg. Co. Inc.  
 Aeronautical Mfg. Corp.  
 Air Associates, Inc.  
 Air Communications, Inc.  
 Aircraft Instrument Service, Inc  
 Airdesign & Fabrication, Inc  
 Allis-Chalmers Mfg. Co.  
 American Phenolic Corp.  
 Appleton Electric Co.  
 The M. B. Austin Co.  
 Automatic Electric Co.  
 Automatic Electrical Devices Co.  
 The B G Corp.  
 Baldor Electric Co.  
 Bendix Aviation Corp., Pacific Div.  
 Bendix Aviation Corp., Philadelphia Div.  
 The Benwood Linze Co.  
 The W. W. Boes Co.

THIS BAG *Eliminates Time Loss*  
 BETWEEN PRODUCTION LINE AND FIRING LINE



Davison's Protek-Sorb Silica Gel has changed a lot of thinking about packaging because, in the urgency of war, it proved its ability to completely eliminate moisture damage to vital equipment during shipment or storage.

Method II dehydrated packing (in which Davison pioneered) with Davison's Protek-Sorb Silica Gel, prevents moisture damage by keeping relative humidity well below 30% INSIDE the package . . . rust and corrosion cannot take place. . . . Protek-Sorb removes the cause . . . moisture vapor. It saves time and cost of cleaning, deslushing . . . the packaged product is ready for immediate use.

The advantages of dehydrated packaging with Davison's Protek-Sorb Silica Gel can be applied to your present product . . . to your post-war products. Consult us on your packaging problems.

**DAVISON'S PROTEK-SORB  
 SILICA GEL IS USED TODAY  
 TO SUCCESSFULLY PACKAGE**

- Complete Engines
- Complete Airplanes
- Cylinders (run-in, with piston and ring)
- Crank and propeller shafts
- Carburetors, pumps, magnetos
- Engine superchargers
- Propeller parts
- Governors and Aircraft Instruments
- Bomb sights
- Machine guns

THE DAVISON CHEMICAL CORPORATION  
*Progress through Chemistry* **D** BALTIMORE 3, MD.

**(Electrical Equipment) Continued**

Breuer Electric Mfg. Co.  
 Burndy Engineering Co., Inc.  
 Cannon Electric Development Co.  
 Clifford Manufacturing Co.  
 Cole-Hersee Co.  
 Day-Ray Products, Inc.  
 Delco-Remy Div., General Motors Corp.  
 Diehl Manufacturing Co.  
 Dietz Mfg. Co.  
 Drake Manufacturing Co.  
 E. A. Laboratories, Inc.  
 Eastern Air Devices, Inc.  
 Eclipse-Pioneer Div., Bendix Aviation Corp.  
 Federal Telephone & Radio Corp.  
 The Fostoria Pressed Steel Corp.  
 General Aircraft Supply Corp.  
 General Electric Co.  
 Gould Storage Battery Corp.  
 Hope Webbing Co.  
 Irvington Varnish & Insulator Co.  
 Howard B. Jones  
 Kellogg Switchboard & Supply Co.  
 Kenyon Instrument Co., Inc.  
 King Plastics Corp.  
 Kulka Electric Mfg. Co., Inc.  
 Lasalco Inc.  
 Leach Relay Co., Inc.  
 The Leece-Neville Co.  
 Leland Electric Co., Inc.  
 Liberty Motors & Engineering Corp.  
 Littelfuse Inc.  
 P. R. Mallory & Co., Inc.  
 Micro Switch Corp.  
 Models, Inc.  
 Mu-Switch Corp.  
 North American Electric Lamp Co.  
 The Ohio Crankshaft Co.  
 Operadio Manufacturing Co.  
 Otto Aviation Corp.  
 Perry Metal Products Co. Inc.  
 Plastic Manufacturers, Inc.  
 Pollak Manufacturing Co.  
 Rohr Aircraft Corp.  
 Scintilla Magneto Div., Bendix Aviation Corp.  
 St. Louis Radio-Engineering Co.  
 Samson United Corp.  
 Selectar Mfg. Co.  
 F. A. Smith Manufacturing Co. Inc.  
 J. Earl Smith  
 Spencer Thermostat Co.  
 Standard Aircraft Products, Inc.  
 The States Co.

Thordarson Electric Mfg. Co.  
 Trans-American Airports Corp.  
 United-Carr Fastener Corp.  
 United Transformer Co.  
 Wabash Appliance Corp.  
 Ward Leonard Electric Co.  
 Westinghouse Electric & Manufacturing Co.  
 White-Rodgers Electric Co.

**Auxiliary Motors**

Air Associates, Inc.  
 Baldor Electric Co.  
 Barber-Colman Co.  
 Bendix Aviation Corp., Pacific Div.  
 Bendix Aviation Corp., Philadelphia Div.  
 Century Electric Co.  
 Diehl Manufacturing Co.  
 Eclipse-Pioneer Div., Bendix Aviation Corp.  
 L. M. Gear Co.  
 General Electric Co.  
 Gilfillan Bros. Inc.  
 Jack & Heintz, Inc.  
 Lawrance Aeronautical Corp.  
 The Leece-Neville Co.  
 Leland Electric Co., Inc.  
 Otto Aviation Corp.  
 F. A. Smith Manufacturing Co. Inc.  
 Westinghouse Electric & Manufacturing Co.  
 White-Rodgers Electric Co.

**Disconnect Plugs**

Air Associates, Inc.  
 Edward F. Aymond Co.  
 Bendix Aviation Corp., Philadelphia Div.  
 Breeze Corporations, Inc.  
 Cannon Electric Development Co.  
 Cole-Hersee Co.  
 The Harwood Co., Div. of Los Angeles Corp.  
 Howard B. Jones  
 Kellogg Switchboard & Supply Co.  
 Kenyon Instrument Co., Inc.  
 Kliegel Bros. Universal Electric Stage Lighting Co., Inc.  
 Kulka Electric Mfg. Co., Inc.  
 Operadio Manufacturing Co.  
 Otto Aviation Corp.  
 Pollak Manufacturing Co.  
 The Pyle-National Co.

**BATTLE  
TESTED**



**COMMUNICATION AND ELECTRICAL EQUIPMENT *by* KELLOGG**



**Military  
Switchboards**



**Multi-contact  
Plugs and Sockets**



**Head and Chest  
Sets**



**Capacitors — Wax  
and Oil Impregnated**



**Aircraft Radio  
Noise Filters**



**Volume Controls**



**Microphones —  
All Types**



**Retractable Electrical  
Coiled Kords**

• The greatest proving grounds in the world are the many fighting fronts on which equipment of every type meets the supreme test. Communication equipment, so vital to modern warfare, must measure up to highest standards of performance and dependability. Both are qualities which the Kellogg Company has been building into fine communication equipment for almost half a century—qualities which are being built into the products shown above. These and other Kellogg items—telephone and telegraph sets, cord assemblies, jacks and plugs, etc.—are manufactured in great quantities for the Armed Forces. If your present or anticipated requirements call for similar equipment or parts, call on Kellogg for sound, practical recommendations.

**KELLOGG SWITCHBOARD & SUPPLY CO.**  
6650 So. Cicero Avenue, Chicago 38, Illinois

**KELLOGG**

*For Communication  
Equipment*

WHERE ENGINEERING AND RESEARCH BUILD

FOR WAR AND PEACE

**Dynamotors**

Bendix Aviation Corp., Pacific Div.  
 Bendix Aviation Corp., Philadelphia Div.  
 Bendix Radio Div. of Bendix Aviation Corp.  
 Diehl Manufacturing Co.  
 Eclipse-Pioneer Div., Bendix Aviation Corp.  
 L. M. Gear Co.  
 General Armature Corp.  
 General Electric Co.  
 Westinghouse Electric & Manufacturing Co.

**Generators**

Aircraft Instrument Service, Inc.  
 Bendix Aviation Corp., Pacific Div.  
 Bendix Aviation Corp., Philadelphia Div.  
 Century Electric Co.  
 Diehl Manufacturing Co.  
 Eclipse-Pioneer Div., Bendix Aviation Corp.  
 The Electric Auto-Lite Co.  
 L. M. Gear Co.  
 General Aircraft Supply Corp.  
 General Armature Corp.  
 General Electric Co.  
 Jack & Heintz, Inc.  
 Lasalco Inc.  
 The Leece-Neville Co.  
 Leland Electric Co., Inc.  
 Moore-Eastwood & Co.  
 Westinghouse Electric & Manufacturing Co.

**Governors**

Woodward Governor Co.

**Magnetos**

Aircraft Instrument Service, Inc.  
 American Bosch Corp.  
 Bendix Aviation Corp.  
 Cook Electric Co.  
 Delco-Remy Div., General Motors Corp.  
 The Denison Engineering Co.  
 General Aircraft Supply Corp.  
 General Electric Co.  
 Scintilla Magneto Div., Bendix Aviation Corp.  
 Trans-American Airports Corp.  
 Eisemann Corp.

**Rectifiers**

The Benwood Linze Co.

**Relays**

Allied Control Co., Inc.  
 Automatic Electric Co.  
 C. P. Clare & Co.  
 Cook Electric Co.  
 Delco-Remy Div., General Motors Corp.  
 The Electric Auto-Lite Co.  
 Guardian Electric Mfg. Co.  
 H-B Electric Co., Inc.  
 Jack and Heintz, Inc.  
 Kellogg Switchboard & Supply Co.  
 Leach Relay Co., Inc.  
 The Leece-Neville Co.  
 J. Earl Smith  
 Ward Leonard Electric Co.

**Rheostats**

Perry Metal Products Co., Inc.  
 J. Earl Smith  
 Ward Leonard Electric Co.

**Switches**

Acro Electric Co.  
 Air Associates, Inc.  
 Allied Control Co., Inc.  
 Cole-Hersee Co.  
 Delco-Remy Div., General Motors Corp.  
 Eisemann Corp.  
 General Electric Co.  
 Kellogg Switchboard & Supply Co.  
 Kulka Electric Mfg. Co., Inc.  
 Littelfuse Inc.  
 Perry Metal Products Co. Inc.  
 J. Earl Smith  
 Trans-American Airports Corp.

**Terminals**

Air Associates, Inc.  
 The M. B. Austin Co.  
 Cole-Hersee Co.  
 Cook Electric Co.  
 Eisemann Corp.  
 General Aircraft Supply Corp.  
 Kellogg Switchboard & Supply Co.  
 Kulka Electric Mfg. Co., Inc.  
 Littelfuse Inc.

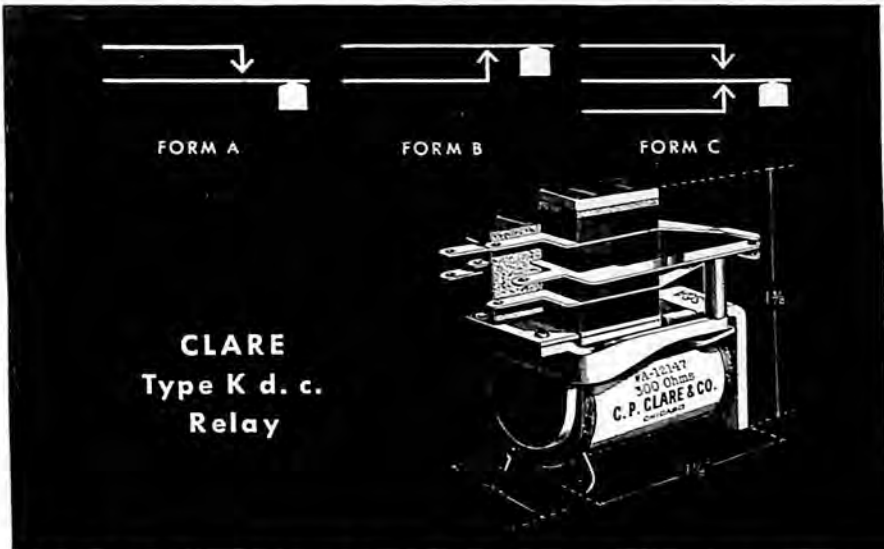

**CLARE**  
Type K d. c.  
Relay

## This Relay Laughs at Vibration

THE Clare Type K d. c. Midget Relay pictured above was "custom-built" for mobile applications, such as aircraft, where dwarf-size and feather-weight are imperative; where ability to operate on high frequency circuits is essential; where resistance to constant vibration and severe shock is a "must."

Its construction employs no anti-vibration springs, no loose bearings, no rivets, no gingerbread whatsoever . . . The screws which anchor spring pile-ups to the heelpiece are tightened under pressure and sealed by a coating of Glyptol.

It is extremely small, measuring only 1½" x 1¼" x 13/16" and weighs approximately 1⅓ ounces . . . It can be furnished in the contact forms shown above with any number of springs up to and including 12. Coil voltage range from 1.5 volts to 60 volts d.c. . . . Contacts of either 18 gauge silver, rated one ampere, 50 watts, or 18 gauge palladium, rated 2 amperes, 100 watts. All metal parts of this relay are specially plated to withstand a 200 hour salt spray test.

The size and weight of this relay is a very definite contribution to aircraft design problems. Write us regarding your problems. We will make suggestions. Send for the Clare catalog and data book. C. P. Clare & Company, 4719 West Sunnyside Ave., Chicago, Ill. Sales engineers in all principal cities. Cable address: CLARELAY.

### Special Features

1. Spring insulators of ⅛" Mycalex are provided for high frequency circuits.
2. Pile-up screws are enclosed in Polystyrene tubing insulation. Both screws and tubing are completely sealed at head and foot by Glyptol.
3. The armature assembly, heelpiece and coil core are made of magnetic metal, carefully annealed. The armature assembly is available with either single or double arm.
4. The small coil is equipped with a front spool head having a flat side. This locks the entire coil in place against the heelpiece, preventing it from turning or becoming loose.
5. Uniform armature movement is assured by a hinge of "fatigueless" beryllium copper, heat treated and designed to provide a wide margin of safety, insuring long life under vibration.
6. Contact springs are made of nickel silver to the user's specifications. The contacts are over-all welded to these springs by a special process.
7. Spring bushing insulators are made of Bakelite rod under a patented process.

# CLARE RELAYS

"Custom-built" Multiple Contact Relays for Electrical, Electronic and Industrial Use



**(Terminals) Continued**

Perry Metal Products Co. Inc.  
Trans-American Airports Corp.

**ENGINE EQUIPMENT**

Aero Supply Mfg. Co. Inc.  
Aircraft Screw Products Co., Inc.  
Allen Electric & Equipment Co.  
Aluminum Goods Mfg. Co.  
American Machine & Metals, Inc.  
Angelus Steel Treating Co.  
The Aro Equipment Corp.  
The Buda Co.  
Clifford Manufacturing Co.  
The Fulton Sylphon Co.  
Kenyon Instrument Co., Inc.  
The MB Manufacturing Co. Inc.  
Major Aircraft Foundry  
The Marquette Metal Products Co.  
Models, Inc.  
The Ohio Piston Co.  
Otto Aviation Corp.  
Perry Metal Products Co. Inc.  
Ritter Co., Inc.  
Simmonds Aeroaccessories, Inc.  
Standard Aircraft Products, Inc.  
Taylor Manufacturing Co.  
Trans-American Airports Corp.  
United Aircraft Products, Inc.  
The Vimalert Co., Ltd.  
The Weatherhead Co.

**ENGINE MOUNTS**

Aircraft Components, Inc.  
Aircraft Products, Inc.  
Aircraft Welders, Inc.  
Associated Rubber Products Co.  
B. H. Aircraft Co.  
The Bowling Green Rubber Co.  
Bushings, Inc.  
Colgate Aircraft Corp.  
Connecticut Hard Rubber Co.  
Firestone Aircraft Co.  
The B. F. Goodrich Co.  
Harris Products Co.  
Hayes Manufacturing Corp.  
Hockaday Aircraft Corp.  
Keystone Aircraft Products, Inc.  
The MB Manufacturing Co. Inc.  
Perry Metal Products Co. Inc.  
Pollak Manufacturing Co.  
Rohr Aircraft Corp.  
Taylorcraft Aviation Corp.

Trans-American Airports Corp.  
Tyler Fixture Corp.  
United States Rubber Co.

**ENGINE PARTS**

Ace Manufacturing Corp.  
Adel Precision Products Corp.  
Aero Trades Co.  
Aircraft Mechanics, Inc.  
The American Auto Parts Co.  
Angelus Steel Treating Co.  
The Buda Co.  
General Aircraft Supply Corp.  
The Govro-Nelson Co.  
Guiberson Diesel Engine Co.  
Hartford Machine Screw Co.  
Liberty Aircraft Products Corp.  
The Ohio Crankshaft Co.  
The Ohio Piston Co.  
Pacific Gear Plant, Western Gear  
Works  
Perry Metal Products Co. Inc.  
Ritter Co., Inc.  
Rohr Aircraft Corp.  
Special Machine Tool Engineering  
Works  
Thompson Products, Inc.  
Trans-American Airports Corp.  
Waldes Koh-I-Noor, Inc.  
N. A. Woodworth Co.

**Cams**

Guiberson Diesel Engine Co.  
Kropp Forge Aviation Co.  
Perry Metal Products Co. Inc.  
Spaulding Fibre Co., Inc.  
Special Machine Tool Engineering  
Works  
Trans-American Airports Corp.  
N. A. Woodworth Co.

**Camshafts**

Guiberson Diesel Engine Co.  
Kropp Forge Aviation Co.  
The Ohio Crankshaft Co.  
Special Machine Tool Engineering  
Works  
Trans-American Airports Corp.

**Crankshafts**

Guiberson Diesel Engine Co.  
Harvey Machine Co., Inc.

# CLIFFORD MANUFACTURING CO.

BOSTON 27, MASS.

Manufacturers of **HYDRON METALLIC BELLOWS** and  
**FEATHER-WEIGHT OIL COOLERS** and **COOLANT RADIATORS**



Feather-weight **ALL ALUMINUM ALLOY**  
**AIRCRAFT OIL COOLERS** AND **COOLANT**  
**RADIATORS . . .**

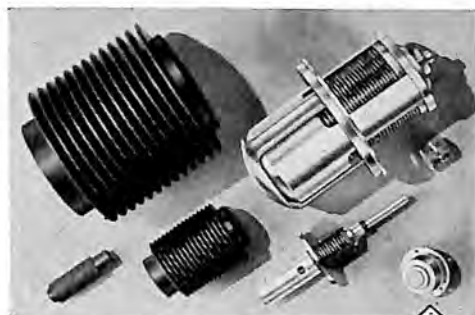

## HYDRON BELLOWS

Industry's first hydraulically  
formed bellows



*Let our engineering department demonstrate to you how Clifford has won the reputation of being the leader in bellows engineering.*

**44 PAGE ENGINEER'S DATA BOOK IS YOURS FOR THE ASKING.**

Address **CLIFFORD MANUFACTURING CO., Boston 27, Mass.**

- . . . Save 2/3 the Weight
- Now replacing copper oil coolers and coolant radiators—same size and shape—in two types of fighting plane of the USAAF.
- Saving approximately 120 lbs. in one plane. Total potential saving of approximately 320 lbs. in the other.
- Clifford's discovery of how to braze aluminum in thin sections made possible these victories over weight.
- Although entire production is now devoted to United States Army Air Forces, experimental work is in progress on various sizes and shapes of oil coolers and coolant radiators.
- Hydron tubing for aircraft oil coolers, coolant radiators, inter-coolers and after-coolers is extruded by methods invented by Clifford engineers.

- Clifford's engineering skill, which first brought hydraulically formed seamless metallic bellows out of the laboratory stage, is now being devoted to designing and producing:
- Hydron metallic bellows.
  - Bellows assemblies for remote and direct temperature control, for remote control of gasoline valves, for oxygen regulators, for oxygen flow indicators, for refrigerator controls, etc.
  - Thermostatic units for liquid cooled aircraft engines, for refrigerator switches.
  - Pressure and temperature indicating units for submarine and surface Diesels.
  - Bellows shaft seals for automotive fluid transmissions, fuel oil pumps and refrigerator compressors.
  - Patented steam trap bellows.

**(Crankshafts) Continued**

Kropp Forge Aviation Co.  
The Ohio Crankshaft Co.  
Trans-American Airports Corp.

**Pistons**

Guiberson Diesel Engine Co.  
McQuay-Norris Manufacturing Co.  
The Ohio Piston Co.  
Trans-American Airports Corp.  
Tube Turns, Inc.

**Rings**

General Aircraft Supply Corp.  
Koppers Co., American Hammered  
Piston Ring Div.  
Muskegon Piston Ring Co.  
Ramsey Accessories Mfg. Corp.  
Richmond Ring Co.  
Special Machine Tool Engineering  
Works  
Trans-American Airports Corp.  
Waldes Koh-I-Noor, Inc.

**Shims**

Perry Metal Products Co. Inc.  
Spaulding Fibre Co., Inc.  
Trans-American Airports Corp.

**Valves & Valve Parts**

Adel Precision Products Corp.  
Air Associates, Inc.  
Airesearch Manufacturing Co.  
Alco Valve Co.  
The American Auto Parts Co.  
The Apex Tool Co., Inc.  
Arnolt Motor Corp.  
The Brewer-Titchener Corp.  
Hartford Machine Screw Co.  
Koehler Aircraft Products Co.  
The Parker Appliance Co.  
Perry Metal Products Co. Inc.  
Special Machine Tool Engineering  
Works  
Thompson Products, Inc.  
Trans-American Airports Corp.  
The Weatherhead Co.  
N. A. Woodworth Co.

**EXHAUST  
MANIFOLDS**

Aero Trades Co.  
Air Craftsmen, Inc.

Aircraft Components Inc.  
Aircraft Products, Inc.  
American Central Manufacturing  
Corp.  
American Tube Bending Co., Inc.  
Angelus Steel Treating Co.  
B. H. Aircraft Co.  
The Brewer-Titchener Corp.  
Guiberson Diesel Engine Co.  
Hayes Manufacturing Corp.  
Hockaday Aircraft Corp.  
Keystone Aircraft Products, Inc.  
Major Aircraft Foundry  
Perry Metal Products Co. Inc.  
Pollak Manufacturing Co.  
Roberts & Mander Stove Co.  
Rohr Aircraft Corp.  
Scott Aviation Corp.  
Solar Aircraft Co.  
Taylorcraft Aviation Corp.  
Thompson Products, Inc.  
Trans-American Airports Corp.  
Tyler Fixture Corp.

**FABRICS, CLOTHS,  
TAPES**

Atlantic Rayon Corp., Industrial  
Fabrics Div.  
Backstay Welt Co.  
L. C. Chase & Co.  
Columbus Coated Fabrics Corp.  
C. R. Daniels, Inc.  
Firestone Aircraft Co.  
General Aircraft Supply Corp.  
Industrial Fabrics Div.  
John W. Gillette & Co.  
The B. F. Goodrich Co.  
Hope Webbing Co.  
Irvington Varnish & Insulator Co.  
Johns-Manville Sales Corp.  
Massachusetts Mohair Plush Co.  
Owens-Corning Fiberglas Corp.  
James H. Rhodes & Co.  
Thompson Products, Inc.  
Trans-American Airports Corp.

**FAIRINGS**

Aero Trades Co.  
Aircraft Containers Co.  
Capac Manufacturing Co.  
Colgate Aircraft Corp.  
Edo Aircraft Corp.  
G & H Tool and Manufacturing Co.  
Haskelite Manufacturing Corp.



ESTABLISHED  
1919

**SAFE**

DEPENDABLE LIGHT WEIGHT DIESEL

**POWER**

FOR PLANES, TANKS AND SHIPS

- ★ LOW FUEL CONSUMPTION
- ★ LOW FUEL COST
- ★ NO INJECTION SYSTEM
- ★ NO FIRE HAZARD
- ★ DEPENDABLE OPERATION

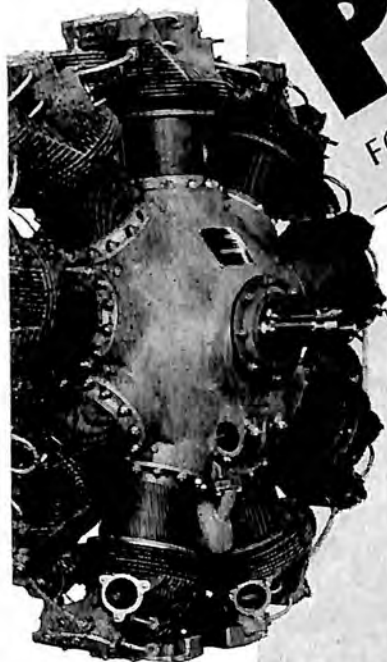

**THE  
GUIBERSON**

AMERICA'S ONLY  
RADIAL AIR-COOLED  
DIESEL ENGINE

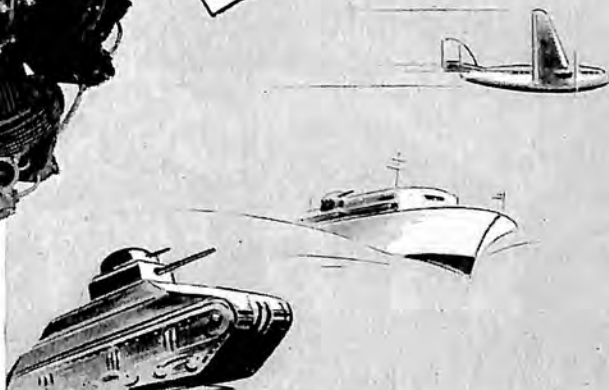

*Guiberson U.S.A.*

GUIBERSON DIESEL ENGINE COMPANY ★ THE GUIBERSON CORPORATION  
Dallas, Texas Aircraft and Heater Division

**Send for  
this book  
FREE!**

THE FIRST NAME IN TUBE BENDING  
**AMERICAN**



20 pages of  
pictures and  
Engineering  
Information.

34 years experience. Specialists in Thin Wall Ferrous and Non-Ferrous Metals. To exacting specifications.

**AMERICAN TUBE BENDING CO. INC.** 13 LAWRENCE ST.  
NEW HAVEN 11, CONN.

**WORLD'S PREMIER AIRPLANE FABRIC**

**LIGHTER**

**STRONGER**

**SMOOTHER**

**FLIGHTEX**

**ATLANTIC RAYON CORP.**

**INDUSTRIAL FABRICS DIVISION**  
350 Fifth Avenue New York 1, N. Y.

Leading Manufacturers of Fabric and Tapes for the Aircraft industry.



Export Representative—Aviqualpo, Inc.,  
25 Beaver St., N. Y.  
Cable Add: 'Aviqualpo'



*AVIQUIPO*

25 BEAVER STREET, NEW YORK 4, N. Y.



**(Fairings) Continued**

Kilgen Aircraft, Div. The Kilgen Organ Co.  
 King Plastics Corp.  
 Marine-Air Research Corp.  
 The Murray Corp. of America  
 Rohr Aircraft Corp.  
 Taylorcraft Aviation Corp.  
 Westinghouse Electric & Manufacturing Co.  
 E. W. Wiggins Airways, Inc.

**FASTENERS, NUTS,  
 BOLTS, SCREWS  
 & WASHERS**

Adel Precision Products Corp.  
 Aero Supply Mfg. Co. Inc.  
 Aeronautical Products, Inc.  
 Air Associates, Inc.  
 Aircraft Hardware Mfg. Co.  
 Aircraft Parts Development Corp.  
 Aircraft Screw Products Co., Inc.  
 Aluminum Company of America  
 American Screw Co.  
 Bardwell & McAlister, Inc.  
 Bethlehem Steel Co.  
 Boots Aircraft Nut Corp.  
 Camloc Fastener Corp.  
 Central Screw Co.  
 Chase Brass & Copper Co.  
 Cinch Manufacturing Corp.  
 Continental Screw Co.  
 The Corbin Screw Co.  
 Detroit Stamping Co.  
 Dzus Fastener Co., Inc.  
 General Aircraft Supply Corp.  
 Hartford Machine Screw Co.  
 Keystone Aircraft Products, Inc.  
 Manufacturers Screw Products  
 The National Screw & Mfg. Co.  
 Otto Aviation Corp.  
 Packless Metal Products Corp.  
 The Palnut Co.  
 Perry Metal Products Co. Inc.  
 Pollak Manufacturing Co.  
 James H. Rhodes & Co.  
 Rohr Aircraft Corp.  
 Shakeproof Inc.  
 Simmonds Aerocessories, Inc.  
 Special Machine Tool Engineering Works  
 The Spool Cotton Co.  
 Thompson Products, Inc.  
 Tinnerman Products, Inc.  
 Trans-American Airports Corp.

United-Carr Fastener Corp.  
 United States Rubber Co.  
 Waldes Koh-I-Noor, Inc.  
 N. A. Woodworth Co.

**FILTERS &  
 STRAINERS**

A C Spark Plug Div., General Motors Corp.  
 Adel Precision Products Corp.  
 Aero Supply Mfg. Co. Inc.  
 Aero Trades Co.  
 Air Associates, Inc.  
 Aircraft & Marine Specialty Co.  
 American Central Manufacturing Corp.  
 Eclipse-Pioneer Div., Bendix Aviation Corp.  
 The Felters Co.  
 Gilbert & Barker Mfg. Co.  
 Granberg Equipment Inc.  
 Hub Industries Inc.  
 The Imperial Brass Manufacturing Co.  
 Kenyon Instrument Co., Inc.  
 Koehler Aircraft Products Co.  
 Michigan Wire Cloth Co.  
 Newark Wire Cloth Co.  
 Owens-Corning Fiberglas Corp.  
 Perry Metal Products Co.  
 Purolator Products, Inc.  
 United Aircraft Products, Inc.

**Air**

A C Spark Plug Div., General Motors Corp.  
 Aero Trades Co.  
 Air-Maze Corp.  
 American Air Filter Co., Inc.  
 Eugene Cantin Co., Inc.  
 Eclipse-Pioneer Div., Bendix Aviation Corp.  
 The Felters Co.  
 The Heath Co.  
 Michigan Wire Cloth Co.  
 Newark Wire Cloth Co.  
 Owens-Corning Fiberglas Corp.  
 Perry Metal Products Co.  
 Purolator Products, Inc.

**Oil**

A C Spark Plug Div., General Motors Corp.  
 Adel Precision Products Corp.

# "American Evaluates Pound Saved on a Plane at \$600<sup>00</sup>"

SAYS CHARLES A. RHEINSTROM,  
V. P. TRAFFIC, AMERICAN AIRLINES



"The necessity for exercising the strictest control over a plane's empty weight is constantly being brought home to the manufacturer by the airlines. Pounds saved on military planes, of course, mean additional speed, range, armor, firepower—factors which cannot be evaluated in money. In commercial aviation, however, a lifetime price tag can be attached to reduced weight. It is estimated at American Airlines that the figure on that price tag amounts to \$600.00 during the first five years of the life of a plane for each pound saved."

**SEND FOR BOOTS  
WEIGHT-SAVING BOOKLET TODAY**

Comparative weights of various types of self-locking nuts comprehensively reviewed for the convenience of aircraft designers, engineers, operating and maintenance personnel. Copy will be sent you, free, upon request.

#### UP TO 60 LBS. PER PLANE SAVED BY BOOTS NUTS

- Standard fastenings for all types of military planes—fighters, bombers, cargo carriers.
- Will be standard on commercial planes also after victory.
- Far lighter, but tougher than similar fastenings.
- Approved by all government aviation agencies.
- Can be used over and over again.
- "Outlast the plane."



**ANCHOR NUT—WING STYLE**  
This is one type of the famous Boots All-Metal Self-Locking Nuts

## **BOOTS SELF-LOCKING NUTS** *"They Fly With Their Boots On—Lighter"*

Boots Aircraft Nut Corporation, General Offices,  
New Canaan, Conn., Dept. A-3

**(Oil) Continued**

Aircraft & Marine Specialty Co.  
 Aluminum Goods Mfg. Co.  
 American Bosch Corp.  
 Eugene Cantin Co., Inc.  
 Chase Brass & Copper Co.  
 The Felters Co.  
 The Fostoria Pressed Steel Corp.  
 The Hilliard Corp.  
 Hub Industries Inc.  
 Kenyon Instrument Co., Inc.  
 Michigan Wire Cloth Co.  
 Newark Wire Cloth Co.  
 Perry Metal Products Co. Inc.  
 Purolator Products, Inc.  
 Thompson Products, Inc.

**FINISHES, PAINTS,  
VARNISHES**

Acme White Lead & Color Works  
 Adhere, Inc.  
 Aluminum Industries, Inc.  
 Ault & Wiborg Corp.  
 Avondale Chemical Co.  
 The Barrett Div., Allied Chemical &  
 Dye Corp.  
 Berry Brothers, Inc.  
 Cook Paint & Varnish Co.  
 Dibble Color Co.  
 General Aircraft Supply Corp.  
 Irvington Varnish & Insulator Co.  
 The Lowe Brothers Co.  
 Paasche Airbush Co.  
 Pratt & Lambert Inc.  
 Randolph Finishing Products Co.  
 Roxalin Flexible Finishes Inc.  
 The Sherwin-Williams Co.  
 Titanine, Inc.  
 Trans-American Airports Corp.

**FIRE  
EXTINGUISHERS**

American-La France-Foamite Corp.  
 Buffalo Fire Appliance Corp.  
 C-O-Two Fire Equipment Co.  
 Campbell Hdwe. & Supply Co.  
 Cardox Corp.  
 The Fyr-Fyter Co.  
 General Aircraft Supply Corp.  
 General Scientific Equipment Co.  
 Walter Kidde & Co., Inc.  
 Pyrene Manufacturing Co.  
 Roberts & Mander Stove Co.  
 Trans-American Airports Corp.

**FIRST AID  
EQUIPMENT**

Air Associates, Inc.  
 Automatic Electrical Devices Co.  
 General Aircraft Supply Corp.  
 General Scientific Equipment Co.  
 Mine Safety Appliances Co.

**FITTINGS**

A & F Aluminum Products Co.  
 Adel Precision Products Corp.  
 Aero Supply Mfg. Co. Inc.  
 Aero Trades Co.  
 Aeronautical Mfg. Corp.  
 Air Associates, Inc.  
 Aircraft & Marine Specialty Co.  
 Aircraft Containers Co.  
 Aircraft Instrument Service, Inc.  
 Aircraft Mechanics, Inc.  
 Aircraft Parts Development Corp.  
 Aluminum Company of America  
 American Armament Corp.  
 American Screw Products  
 Associated Foundries & Manufac-  
 turers, Inc.  
 Campbell Hdwe. & Supply Co.  
 Chase Brass & Copper Co.  
 Colgate Aircraft Corp.  
 The Dole Valve Co.  
 General Aircraft Supply Corp.  
 Gilfillan Bros. Inc.  
 The Hardware Specialties Mfg. Co.  
 Hartford Machine Screw Co.  
 Hockaday Aircraft Corp.  
 Hyland Machine Co.  
 The Imperial Brass Manufacturing  
 Co.  
 Lincoln Engineering Co.  
 The M B Manufacturing Co. Inc.  
 Major Aircraft Foundry  
 Otto Aviation Corp.  
 Packless Metal Products Corp.  
 The Parker Appliance Co.  
 Perry Metal Products Co. Inc.  
 Special Machine Tool Engineering  
 Works  
 Taylorcraft Aviation Corp.  
 Trans-American Airports Corp.  
 Union Aircraft Products Corp.  
 Victor Metal Products Corp.  
 The Weatherhead Co.  
 Weber Showcase & Fixture Co., Inc.  
 E. W. Wiggins Airways, Inc.



# A *Specific Finish* FOR EVERY AIRCRAFT NEED

## FABRIC FINISHES:

Emycel speed system of fabric doping  
(C. A. A. approved)

Army-Navy specification clear and pigmented dopes — all types

## METAL FINISHES:

Army-Navy specification Zinc Chromate Primer

Non-specular (camouflage) lacquer enamels

Gloss lacquers

Non-specular (camouflage) synthetic enamels

Rincontrol textured enamels

Flight instrument and communications equipment finishes

Special types engineered for specific performance

## PLYWOOD FINISHES:

Fillers • Sealers • Surfacers

Non-specular lacquer and synthetic enamels

Gasoline resistant lacquers



**ROXALIN** *Flexible* **FINISHES**  
I N C O R P O R A T E D  
ELIZABETH • NEW JERSEY

**FLARES & SIGNALS**

Associated Foundries & Manufacturers, Inc.  
 L. M. Gear Co.  
 General Aircraft Supply Corp.  
 International Flare Signal Div., The Kilgore Manufacturing Co.  
 St. Louis Radio Engineering Co.  
 Trans-American Airports Corp.  
 Warner Manufacturing Co.

**FLOATS, SKIIS**

Aero Parts Manufacturing Co.  
 Aircraft Containers, Inc.  
 Allied Aviation Corp.  
 Associated Foundries & Manufacturers, Inc.  
 Colgate Aircraft Corp.  
 Edo Aircraft Corp.  
 Federal Aircraft Works  
 General Aircraft Supply Corp.  
 Hayes Manufacturing Corp.  
 The Heath Co.  
 Kilgen Aircraft, Div. The Kilgen Organ Co.  
 King Plastics Corp.  
 Marine-Air Research Corp.  
 Mercury Aircraft Inc.  
 Trans-American Airports Corp.

**FORGINGS**

Aero Supply Mfg. Co. Inc.  
 Airchox Co., Div. of Joyce Aviation Inc.  
 Airco Tool Co.  
 Aircraft Mechanics, Inc.  
 Aluminum Company of America  
 American Magnesium Corp.  
 Atlas Drop Forge Co.  
 Bethlehem Steel Co.  
 The Billings & Spencer Co.  
 The Brewer-Titchener Corp.  
 Chase Brass & Copper Co.  
 Columbia Steel Co.  
 Highbridge-International Co.  
 Kropp Forge Aviation Co.  
 Mechanical Products, Inc.  
 Ohlsson & Rice Manufacturing Co.  
 The Paulson Tools Inc.  
 Perry Metal Products Co. Inc.  
 Revere Copper and Brass Inc.  
 Reynolds Metals Co.  
 Ritter Co., Inc.

Transue & Williams Steel Forging Corp.  
 Tube Turns, Inc.  
 Wyman-Gordon Co.

**FUEL PUMPS & SYSTEMS (AIRCRAFT)**

A C Spark Plug Div., General Motors Corp.  
 Adel Precision Products Corp.  
 Aero Supply Mfg. Co. Inc.  
 Aircraft Instrument Service, Inc.  
 American Bosch Corp.  
 The Aro Equipment Corp.  
 Bendix Aviation Corp., Philadelphia Div.  
 Chicago Metal Hose Corp.  
 Clifford Manufacturing Co.  
 Fuel Injection Corp.  
 L. M. Gear Co.  
 Hoof Products Co.  
 Jack & Heintz, Inc.  
 Kenyon Instrument Co., Inc.  
 Lane Wells Co.  
 Mobile Refrigeration Div., Bowser, Inc.  
 Nash Engineering Co.  
 Perry Metal Products Co.  
 Pesco Products Co., Div. of Borg-Warner  
 Rohm Manufacturing Co., Inc.  
 Standard Aircraft Products, Inc.  
 Thompson Products, Inc.  
 Trans-American Airports Corp.  
 United Aircraft Products, Inc.

**FUEL SYSTEMS (AIRPORT)**

Gilbert & Barker Mfg. Co.  
 Mobile Refrigeration Div., Bowser, Inc.  
 Photoswitch Inc.  
 Geo. D. Roper Corp.

**FUELS**

The Atlantic Refining Co.  
 Socony-Vacuum Oil Co., Inc.  
 Standard Oil Co. of California  
 The Texas Co.  
 Tide Water Associated Oil Co.

**GASKETS**

Alpha Metals, Inc.  
 Armstrong Cork Co.

# ***EDO FLOAT GEAR***

*All-metal seaplane floats for every type of aircraft*

★ **MILITARY — SINGLE-FLOAT GEAR**



★ **AMPHIBIOUS — TWIN-FLOAT GEAR**  
with retractable wheels

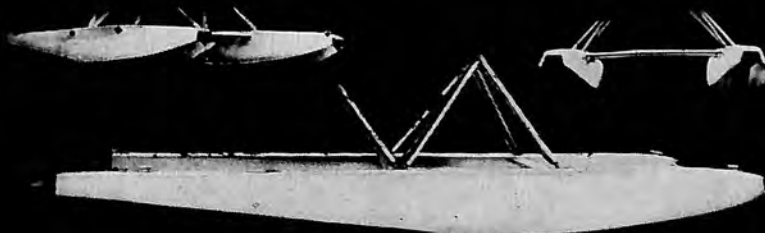

★ **COMMERCIAL — TWIN-FLOAT GEAR**

## ***Edo Aircraft Corporation***

Contractors to the U.S. Navy and U.S. Army Air Forces and Allied Governments

418 SECOND STREET, COLLEGE POINT, N.Y., U.S.A.



**(Gaskets) Continued**

Associated Rubber Products Co.  
 Atlantic India Rubber Works, Inc.  
 Automatic Electrical Devices Co.  
 The B G Corp.  
 Babbitt Industrial Specialties Co.  
 Backstay Welt Co.  
 The Bowling Green Rubber Co.  
 Burlington Mills, Inc.  
 Chase Brass & Copper Co.  
 Connecticut Hard Rubber Co.  
 The Felters Co.  
 Firestone Aircraft Co.  
 The Garlock Packing Co.  
 General Aircraft Supply Corp.  
 The B. F. Goodrich Co.  
 Hoof Products Co.  
 Johns-Manville Sales Corp.  
 Linear Packing & Rubber Co., Inc.  
 Otto Aviation Corp.  
 Radiator Specialty Co.  
 James H. Rhodes & Co.  
 Spaulding Fibre Co., Inc.  
 Trans-American Airports Corp.  
 United States Rubber Co.

**GEARS**

The Adams Co.  
 Campbell Hdwe. & Supply Co.  
 Farrel-Birmingham Co., Inc.  
 Foote Bros. Gear & Machine Corp.  
 L. M. Gear Co.  
 Gleason Works  
 Link-Belt Co.  
 Pacific Gear Plant, Western Gear  
 Works  
 Perry Metal Products Co., Inc.  
 Trans-American Airports Corp.  
 Vard Inc.  
 Vinco Corp.

**GLASS**

Semon Bache & Co.  
 Owens-Corning Fiberglas Corp.  
 Trans-American Airports Corp.  
 The Univis Lens Co.

**GLUES & ADHESIVES**

Allied Aviation Corp.  
 Avondale Chemical Co.  
 Casein Company of America  
 General Aircraft Supply Corp.  
 The B. F. Goodrich Co.

King Plastics Corp.  
 Lauxite Corp.  
 Mono Waterproof Glue Co.  
 Mono Service Co.  
 Plaskon Div., Libbey-Owens-Ford  
 Glass Co.  
 United States Plywood Corp.  
 United States Rubber Co.

**GROMMETS**

Arens Controls, Inc.  
 Atlantic India Rubber Works, Inc.  
 The Bowling Green Rubber Co.  
 Burlington Mills, Inc.  
 Camloc Fastener Corp.  
 Cinch Manufacturing Corp.  
 The Felters Co.  
 Firestone Aircraft Co.  
 General Aircraft Supply Corp.  
 The B. F. Goodrich Co.  
 The Heath Co.  
 Otto Aviation Corp.  
 Pierce Plastics, Inc.  
 Spaulding Fibre Co., Inc.  
 Edwin B. Stimpson Co., Inc.  
 Trans-American Airports Corp.

**HARDWARE  
(MISCELLANEOUS)**

The Adams & Westlake Co.  
 Aero Supply Mfg. Co. Inc.  
 Aero Trades Co.  
 Air Associates, Inc.  
 Airchox Co., Div. of Joyce Aviation  
 Inc.  
 Aircraft & Marine Specialty Co.  
 Airsealand Aircraft, Inc.  
 American Foundry & Furnace Co.  
 American Screw Products  
 Arnolt Motor Co.  
 Edward F. Aymond Co.  
 Campbell Hdwe. & Supply Co.  
 Chase Brass & Copper Co.  
 Cinch Manufacturing Corp.  
 Cook Electric Co.  
 Fox Co.  
 General Aircraft Supply Corp.  
 Hartford Machine Screw Co.  
 Highbridge-International Co.  
 Hyland Machine Co.  
 King Plastics Corp.  
 Major Aircraft Foundry  
 Otto Aviation Corp.

# THE VITAL TENTH

One ten-thousandth of an inch is a minute unit of measurement;—so small that it seems insignificant to the average layman. And it isn't essential in the fitting of a drive of a locomotive.

But it is most important to the boys who service or fly the high-powered airplanes of today—the fighters and bombers that are doing such a tremendous job of breaking the back of the Axis—these boys know how vital that last ten-thousandth of an inch can be. For example, it permits an almost invisible sloppiness or play in the fitting of a propeller to the splines of the drive shaft and this play, with the great power of the engine behind it, can cause serious vibrations which shorten the life of the entire plane by hours.

In the midst of a dog-fight or a bombing mission over Berlin or Rabaul, vibrations of this type, however small, can cost the lives of our fliers and the loss of our planes.

Vinco is one of the few precision gage makers who can produce checking gages and balancing arbors which are satisfactory to the aviation industry. The "vital tenth" is carefully controlled through every operation in the making of these gages.

Vinco's reputation in the making of precision gages has been honestly won during the past quarter century and today, top quality precision gages and Vinco are synonymous. Write for literature.

**VINCO CORPORATION, 8855 SCHAEFER HIGH'Y, DETROIT 27, MICH.**  
SALES OFFICES: . . . . . NEW YORK AND CHICAGO

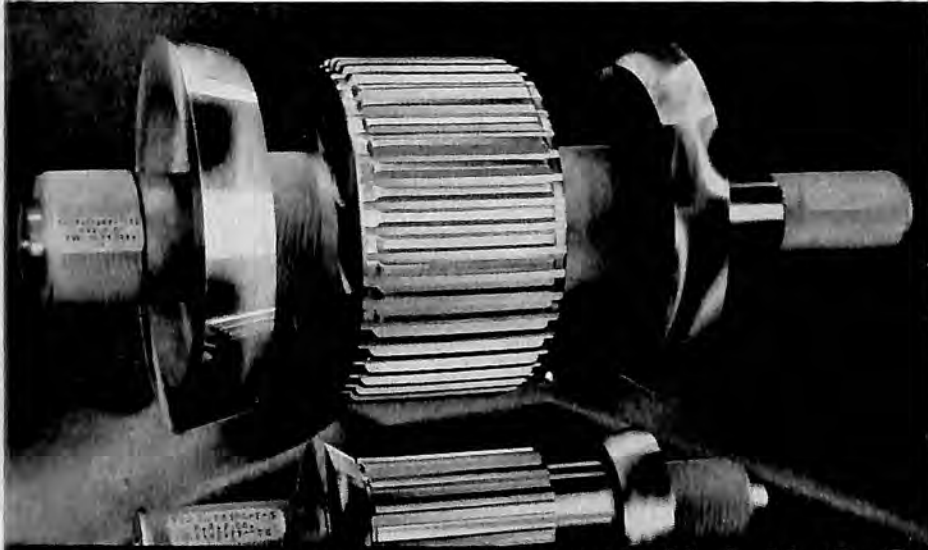
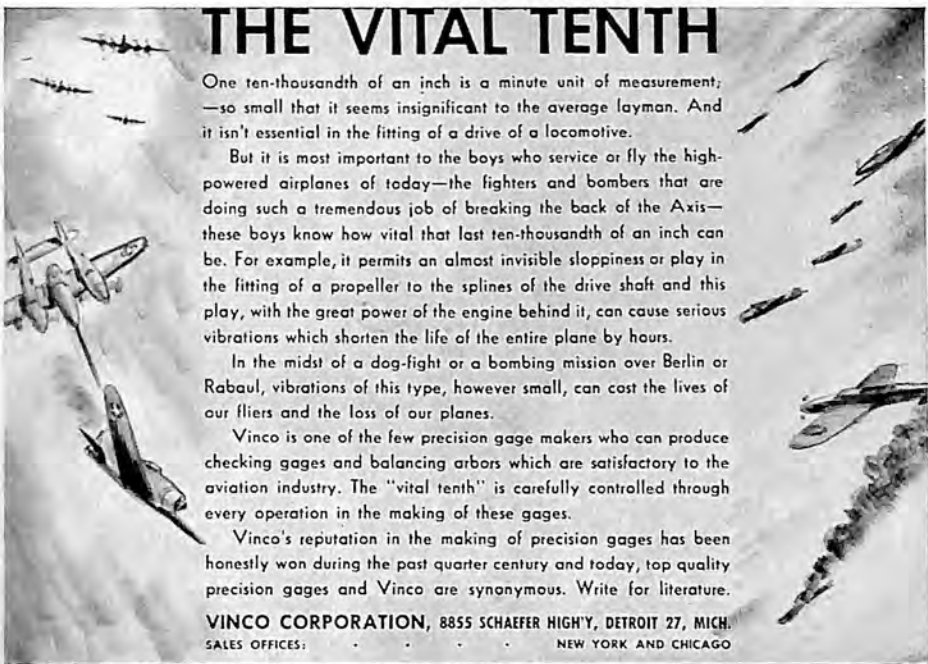

**MILLIONTHS OF AN INCH FOR SALE BY V I N C O**

Semi-Automatic Hydraulic Spline and Gear Grinder • Optical Master Inspection Dividing Head • Involute Checker • Angle Tangent to Radius Dresser  
• Index Plates • Precision Vises • Sine Bars • Straight-side Spline, Serration Spline, Involute Spline and Helical Spline Plug and Ring Gages • Thread  
Plugs, Rings and Setting Plug Gages • Spur and Helical Master Gears • Munition Gages • Propeller Hub Gages • Built-up and Special Gages • Gear  
Rolling Fixtures • Spline and Index Fixtures • Hydraulic Power, Control, Utilization and Distribution Units • Engineering, Design and Development.

**(Hardware Miscellaneous)***Continued*

Perry Metal Products Co. Inc.  
 Rohr Aircraft Corp.  
 Trans-American Airports Corp.  
 Veeder-Root Inc.  
 Weber Showcase & Fixture Co., Inc.

**HEATERS**

Acme Electric Heating Co.  
 Air-Craft Equip. Div. of Anchor Post Fence Co.  
 Ajax Electrothermic Corp.  
 American Chain & Cable Co., Inc.  
 American Instrument Co.  
 Anchor Post Fence Co.  
 Carrier Corp.  
 Clifford Manufacturing Co.  
 Drayer and Hanson, Inc.  
 E. A. Laboratories, Inc.  
 The Folmer Graflex Corp.  
 The Fostoria Pressed Steel Corp.  
 Harvey Machine Co., Inc.  
 McQuay Inc.  
 St. Louis Radio Engineering Co.  
 The States Co.  
 Surface Combustion Corp.  
 Taylorcraft Aviation Corp.  
 Tenney Engineering, Inc.  
 The Trane Co.  
 Harold E. Trent Co.  
 Warner Manufacturing Co.

**HOISTS, CRANES,  
LIFTS, ETC.**

Aircraft Welders, Inc.  
 Automatic Transportation Co., Div. of Yale & Towne Mfg. Co.  
 Baker Industrial Truck Div. The Baker-Raulang Co.  
 Baker-Spiegel Co.  
 Barrett-Cravens Co.  
 Campbell Hdwe. & Supply Co.  
 Chisholm-Moore Hoist Corp.  
 Clark Trutractor Co.  
 Curtis Pneumatic Mchy. Div. of Curtiss Manufacturing Co.  
 Eclipse-Pioneer Div., Bendix Aviation Corp.  
 Federal Aircraft Works  
 Globe Hoist Co.  
 Independent Pneumatic Tool Co.

Lyon-Raymond Corp.  
 Malabar Machine Co.  
 Pacific Gear Plant, Western Gear Works  
 Revolver Co.  
 Tyler Fixture Corp.

**HOSE (RUBBER &  
SYNTHETIC)**

Atlantic India Rubber Works  
 The Bowling Green Rubber Co.  
 Campbell Hdwe. & Supply Co.  
 The De Vilbiss Co.  
 The Flex-O-Tube Co.  
 General Aircraft Supply Corp.  
 The B. F. Goodrich Co.  
 Hewitt Rubber Corp.  
 Independent Pneumatic Tool Co.  
 Irvington Varnish & Insulator Co.  
 Otto Aviation Corp.  
 Packless Metal Products Corp.  
 Pierce Plastics, Inc.  
 Resistoflex Corp.  
 Trans-American Airports Corp.  
 United States Rubber Co.  
 The Weatherhead Co.

**HOSE CLAMPS &  
HOSE FITTINGS**

Actus Products Corp.  
 Adel Precision Products Corp.  
 Aero-Coupling Corp.  
 Aero Screw Co.  
 Aero Supply Mfg. Co. Inc.  
 Aeroquip Corp.  
 Air Associates, Inc.  
 Aircraft Components, Inc.  
 Automotive Rubber Co.  
 The Brewer-Titchener Corp.  
 Chicago Metal Hose Corp.  
 The De Vilbiss Co.  
 Firestone Aircraft Co.  
 The Flex-O-Tube Co.  
 General Aircraft Supply Corp.  
 Heyman Mfg. Co.  
 Independent Pneumatic Tool Co.  
 Otto Aviation Corp.  
 Resistoflex Corp.  
 Screw Machine Products Co., Inc.  
 Trans-American Airports Corp.  
 United-Carr Fastener Corp.  
 United States Rubber Co.



**MOVING THE MATERIALS  
THAT**  
*Move the World*



**P**LANNED materials handling go hand in hand with planned production —

— Costs go down, manpower is saved, time conserved and more floor space is available when Clark Fork Trucks and Tractors are on the job.

"Unskilled labor adds nothing to a product except cost."

Postwar engineering help is available NOW. Write, as we are ready to serve you.

A Product of CLARK EQUIPMENT COMPANY

**CLARK TRUCTRATOR**  
DIVISION OF CLARK EQUIPMENT COMPANY  
BATTLE CREEK, MICHIGAN, U.S.A.

**(Hose Clamps & Hose Fittings)***Continued*

The Weatherhead Co.  
Wittek Manufacturing Co.

**HYDRAULIC  
CONTROLS &  
ASSEMBLIES**

A & F Aluminum Products Co.  
Adel Precision Products Corp.  
Aero-Coupling Corp.  
Aero Trades Co.  
Aeronautical Mfg. Corp.  
Aeroquip Corp.  
Air Associates, Inc.  
Aircraft Accessories Corp.  
Aircraft Containers Co.  
Aircraft Engineering Products, Inc.  
Aircraft Products Co.  
Aircraft Specialties Co.  
Alco Valve Co.  
All American Aircraft Products, Inc.  
American Screw Products  
The Aro Equipment Corp.  
Associated Foundries & Manufacturers Inc.  
Atlantic Diesel Corp.  
Aviquito Manufacturing Corp.  
Bendix Aviation Corp., Pacific Div.  
Bendix Products Div. of Bendix Aviation Corp.  
Chicago Pneumatic Tool Co.  
Clifford Manufacturing Co.  
The Denison Engineering Co.  
Electrol Inc.  
The Flex-O-Tube Co.  
General Controls Co.  
Hoof Products Co.  
Hub Industries Inc.  
Kenyon Instrument Co., Inc.  
Liberty Motors & Engineering Corp.  
Mechanical Products, Inc.  
Menasco Manufacturing Co.  
Models, Inc.  
The Oilgear Co.  
Otto Aviation Corp.  
Pacific Aviation, Inc.  
The Parker Appliance Co.  
Pesco Products Co., Div. of Borg-Warner  
Scott Aviation Corp.  
Simmonds Aerocessories, Inc.  
The Simmons Manufacturing Co.  
Special Machine Tool Engineering Works

Sperry Gyroscope Co., Inc.  
Sperry Products, Inc.  
Standard Aircraft Products, Inc.  
Trans-American Airports Corp.  
United Aircraft Products, Inc.  
Vard Inc.  
Vincor Corp.  
Paul G. Wagner Co.  
The Weatherhead Co.

**I N S T R U M E N T S**

Abrams Instrument Co.  
Adel Precision Products Corp.  
Aircraft Indicators Co.  
Aircraft Instrument Service, Inc.  
Airsealand Aircraft, Inc.  
American Paulin System  
The Aro Equipment Co.  
The Bristol Co.  
The Boston Auto Gage Co.  
Cambridge Instrument Co., Inc.  
Clifford Manufacturing Co.  
Cox & Stevens Aircraft Corp.  
The R. W. Cramer Co., Inc.  
The Davison Chemical Corp.  
De Jur-Amsco Corp.  
Eastern Air Devices, Inc.  
Eclipse-Pioneer Div., Bendix Aviation Corp.  
The Electric Auto-Lite Co.  
Federal Telephone & Radio Corp.  
General Aircraft Supply Corp.  
General Electric Co.  
Granberg Equipment Inc.  
Jack & Heintz, Inc.  
Kellogg Switchboard & Supply Co.  
Kenyon Instrument Co., Inc.  
Kollsman Instrument Div. of Square D Co.  
Lane Wells Co.  
The Lufkin Rule Co.  
Models, Inc.  
Perry Metal Products Co.  
Robertshaw Thermostat Co.  
St. Louis Radio Engineering Co.  
The Sheffield Corp.  
Special Machine Tool Engineering Works  
Sperry Gyroscope Co., Inc.  
Standard Aircraft Products, Inc.  
Herman H. Sticht Co., Inc.  
Tel Autograph Corp.  
Trans-American Airports Corp.  
The Triplett Electrical Instrument Co.

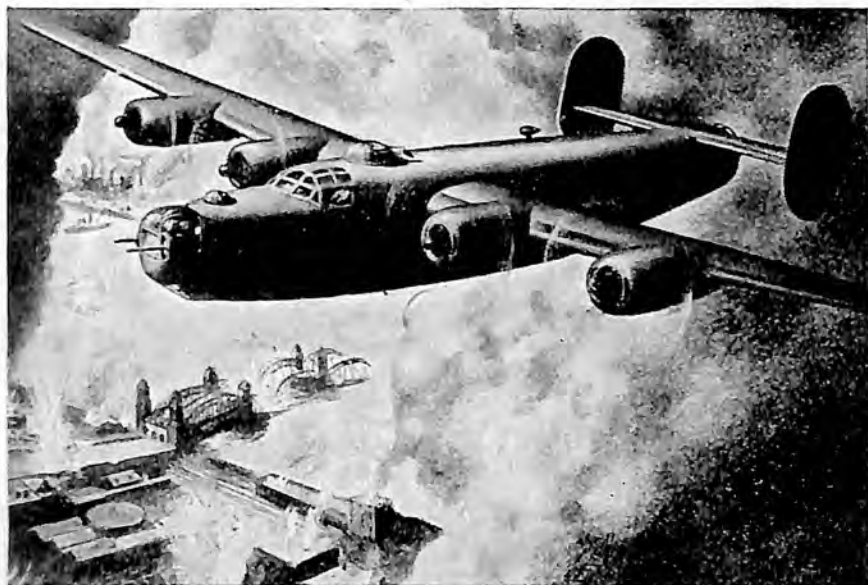

**For the next 20 seconds, the pilot's name is Elmer!**

**A**BOUT 20 seconds elapse between the time a bomber goes into its final run and the time it heads for home.

During these vital 20 seconds, the pilot is the Sperry Gyropilot.\* He's "Elmer" to the U. S. bomber crews—"George" to the R.A.F.

Why is the plane turned over to Elmer? Because Elmer provides the precision control necessary to maneuver the airplane correctly during the bombing run. Elmer holds the ship steadier—truer—than any man can do. His errorless control is one of the reasons for the accuracy of precision bombing.

Sperry developed the first automatic pilot before the last war. It

was designed to increase safety in flight. In 1933, Wiley Post flew around the world alone with the aid of a Sperry Gyropilot.

Sperry Gyropilots were soon standard equipment on transport planes the world over.

When peace comes, Elmer, along with many other Sperry devices, will return to the work for which he was originally designed.

American bombers are now being equipped with the new Sperry Gyrotronic\* Pilot, a precision, electronic version of the Gyropilot.\*

\*Trademarks Registered

**SPERRY GYROSCOPE COMPANY, Inc.**  
BROOKLYN, N. Y.

DIVISION OF THE  SPERRY CORPORATION



(Instruments) *Continued*  
 United States Gauge Co.  
 Westinghouse Electric & Manufacturing Co.

### Electrical

Adel Precision Products Corp.  
 Aircraft Instrument Service, Inc.  
 Bendix Aviation Corp., Philadelphia Div.  
 The W. W. Boes Co.  
 The Brush Development Co.  
 Clifford Manufacturing Co.  
 De Jur-Amsco Corp.  
 Eclipse-Pioneer Div., Bendix Aviation Corp.  
 Federal Telephone & Radio Corp.  
 Jack & Heintz, Inc.  
 Kellogg Switchboard & Supply Co.  
 Kenyon Instrument Co., Inc.  
 Lane Wells Co.  
 Leeds & Northrup Co.  
 The Liquidometer Corp.  
 Models, Inc.  
 Operadio Manufacturing Co.  
 Perry Metal Products Co.  
 Robertshaw Thermostat Co.  
 St. Louis Radio Engineering Co.  
 J. Earl Smith  
 Special Machine Tool Engineering Works  
 Sperry Gyroscope Co., Inc.  
 Standard Aircraft Products, Inc.  
 Herman H. Sticht Co., Inc.  
 Tel Autograph Corp.  
 The Triplett Electrical Instrument Co.  
 Westinghouse Electric & Manufacturing Co.

### Engine

A C Spark Plug Div., General Motors Corp.  
 Aircraft Instrument Service, Inc.  
 Bendix Aviation Corp., Philadelphia Div.  
 Clifford Manufacturing Co.  
 De Jur-Amsco Corp.  
 Eclipse-Pioneer Div., Bendix Aviation Corp.  
 The Electric Auto-Lite Co.  
 L. M. Gear Co.  
 Lane Wells Co.  
 The Liquidometer Corp.  
 Major Aircraft Foundry

Perry Metal Products Co., Inc.  
 Rochester Mfg. Co., Inc.  
 Standard Aircraft Products, Inc.

### Flight

Aircraft Indicators Co.  
 Aircraft Instrument Service, Inc.  
 Bendix Aviation Corp., Philadelphia Div.  
 Cambridge Instrument Co., Inc.  
 Clifford Manufacturing Co.  
 Cox & Stevens Aircraft Corp.  
 Eclipse-Pioneer Div., Bendix Aviation Corp.  
 The Electric Auto-Lite Co.  
 Friez Instrument Div., Bendix Aviation Corp.  
 L. M. Gear Co.  
 General Aircraft Supply Corp.  
 Jack & Heintz, Inc.  
 Kenyon Instrument Co., Inc.  
 Lane Wells Co.  
 Models, Inc.  
 Perry Metal Products Co.  
 Rochester Mfg. Co., Inc.  
 J. Earl Smith  
 Sperry Gyroscope Co., Inc.  
 Trans-American Airports Corp.  
 V. & E. Manufacturing Co.

### INSULATING MATERIALS

American Hair & Felt Co.  
 American Phenolic Corp.  
 Armstrong Cork Co.  
 Atlantic India Rubber Works  
 Edward F. Aymond Co.  
 Backstay Welt Co.  
 Burlington Mills, Inc.  
 Continental-Diamond Fibre Co.  
 The Felters Co.  
 Firestone Aircraft Co.  
 The Formica Insulation Co.  
 The B. F. Goodrich Co.  
 Hope Webbing Co.  
 Irvington Varnish & Insulator Co.  
 Johns-Manville Sales Corp.  
 Manufacturers Chemical Corp.  
 Owens-Corning Fiberglas Corp.  
 Pierce Plastics, Inc.  
 Seaman Paper Co.  
 Spaulding Fibre Co., Inc.  
 Technical Ply-Woods  
 United States Rubber Co.

# ENGINE CONTROLS LIGHTING EQUIPMENT

*for Aircraft*



### COCKPIT LAMP ASSEMBLY

TYPE C-4  
A.A.F. Specification  
94-32294-A  
Standard Aircraft No.  
SA-1007-D  
Used as auxiliary light  
source on all types of aircraft.  
Weight—11 oz.  
Overall size—  
length 5-1/16";  
diameter 1 3/4".



### INTER-CALL SIGNAL BOX

A.A.F. Drawing No.  
43A12392  
Standard Aircraft No.  
SA-2920-B  
Intercommunication call  
light system used when  
interchangeability of crew  
is not possible.  
Weight—5 oz.  
Overall size—length 3";  
width 1 5/8"; depth 2 3/4".



### CABIN LAMP ASSEMBLY

TYPE A-7 VAPOR-PROOF  
Specification  
AN-3039-1 13 VOLT LAMP  
AN-3039-2 28 VOLT LAMP  
Standard Aircraft No.  
SA-2672-B  
Moisture proof. Clear light  
regardless of varying  
atmospheric conditions.  
Wt.—1 1/2 lbs. Overall—  
length 6 7/8"; diameter 5 7/8".



### OIL TANK VENT VALVE

A double action valve which  
maintains a predetermined  
pressure on oil tank thereby  
preventing cavitation in sys-  
tem. Incorporated safety  
feature prevents vacuum  
developing in tank. Weight  
6 oz. Overall size—length  
5 7/8"; width 3"; height 2".



### FUEL TANK PRESSURE CONTROL VALVE

An aneroid valve which pre-  
vents cavitation and vapor-  
lock in fuel system by main-  
taining a predetermined  
pressure in fuel tank under  
all flight conditions. Wt.—  
1 lb., 2 oz. Overall—4 1/4" x 5".



### ALTITUDE COMPENSATING VALVE

A pressure maintaining  
valve which maintains a  
predetermined pressure on  
the system at all times re-  
gardless of altitude. Weight  
—7 oz. Overall size—  
2-9/16" x 1 7/8".

These are only a few of the Standair line of precision controls for aircraft power plants; lighting equipment; accessories; metal stampings. Specified in many leading makes of American, British, Canadian aircraft. Write for data, prices.

STANDAIR



**Standard** AIRCRAFT PRODUCTS, INC., Dayton 2, Ohio

SALES OFFICES:

- {

 Sterling Aircraft Products, Inc., 1831 Graybar Bldg., New York City  
 L. M. Payne Company, Inc., 417 Curtis Building, Detroit, Michigan  
 Hartwell Aviation Supply Co., General Motors Bldg., Detroit, Mich.  
 Hartwell Aviation Supply Co., 3417 Crenshaw Blvd., Los Angeles, Calif.  
 Hartwell Aviation Supply Co., Huron Building, Kansas City, Kansas  
 Hartwell Aviation Supply Co., 608 North St. Paul St., Dallas, Texas

(Insulating Materials) *Continued*  
Westinghouse Electrical & Manufacturing Co.

### LANDING & NAVIGATION LIGHTS

The Adams & Westlake Co.  
Automatic Electrical Devices Co.  
Bardwell & McAlister, Inc.  
Dietz Mfg. Co.  
The Fostoria Pressed Steel Corp.  
General Aircraft Supply Corp.  
Grimes Manufacturing Co.  
Kenyon Instrument Co., Inc.  
Kulka Electric Mfg. Co., Inc.  
Pollak Manufacturing Co.  
St. Louis Radio Engineering Co.  
J. Earl Smith  
Standard Aircraft Products, Inc.  
Trans-American Airports Corp.

### LANDING GEARS

Aerco Corp.  
Aero Trades Co.  
Aeronautical Products, Inc.  
Aircraft & Marine Specialty Co.  
Aircraft Mechanics, Inc.  
Aircraft Products Co.  
Aircraft Welders, Inc.  
Angelus Steel Treating Co.  
Atlantic Diesel Corp.  
Axelson Manufacturing Co.  
Bendix Aviation Corp., Philadelphia Div.  
The Cleveland Pneumatic Tool Co.  
Colgate Aircraft Corp.  
The Denison Engineering Co.  
Firestone Aircraft Co.  
General Aircraft Supply Corp.  
The B. F. Goodrich Co.  
Hockaday Aircraft Corp.  
Hub Industries Inc.  
Jack & Heintz, Inc.  
Keystone Aircraft Products  
Menasco Manufacturing Co.  
Pacific Aviation, Inc.  
Pacific Gear Plant, Weston Gear Works  
Perry Metal Products Co. Inc.  
Geo. D. Roper Corp.  
Special Machine Tool Engineering Works  
Taylorcraft Aviation Corp.

Trans-American Airports Corp.  
United Aircraft Products, Inc.  
E. W. Wiggins Airways, Inc.

### Nose Wheel Assemblies

Aero Trades Co.  
Aircraft Welders, Inc.  
Bendix Products Div. of Bendix Aviation Corp.  
Colgate Aircraft Corp.  
Firestone Aircraft Co.  
Hockaday Aircraft Corp.  
Hub Industries Inc.  
Jack & Heintz, Inc.  
Menasco Manufacturing Co.  
Pacific Aviation, Inc.  
Pacific Gear Plant, Western Gear Works  
Perry Metal Products Co. Inc.  
Geo. D. Roper Corp.  
Trans-American Airports Corp.  
United Aircraft Products, Inc.  
United States Rubber Co.  
E. W. Wiggins Airways, Inc.

### Shock Struts (Hydraulic)

Aero Trades Co.  
Aircraft Products Co.  
Aircraft Welders, Inc.  
Bendix Aviation Corp., Pacific Div.  
Bendix Products Div. of Bendix Aviation Corp.  
The Cleveland Pneumatic Tool Co.  
Firestone Aircraft Co.  
The B. F. Goodrich Co.  
Hockaday Aircraft Corp.  
Hub Industries Inc.  
Menasco Manufacturing Co.  
Ohlsson & Rice Manufacturing Co.  
Pacific Aviation, Inc.  
Perry Metal Products Co. Inc.  
Geo. D. Roper Corp.  
Scott Aviation Corp.  
Special Machine Tool Engineering Works  
Trans-American Airports Corp.  
United Aircraft Products, Inc.

### Tail Wheel Assemblies

Aero Trades Co.  
Aircraft & Marine Specialty Co.  
Aircraft Welders, Inc.

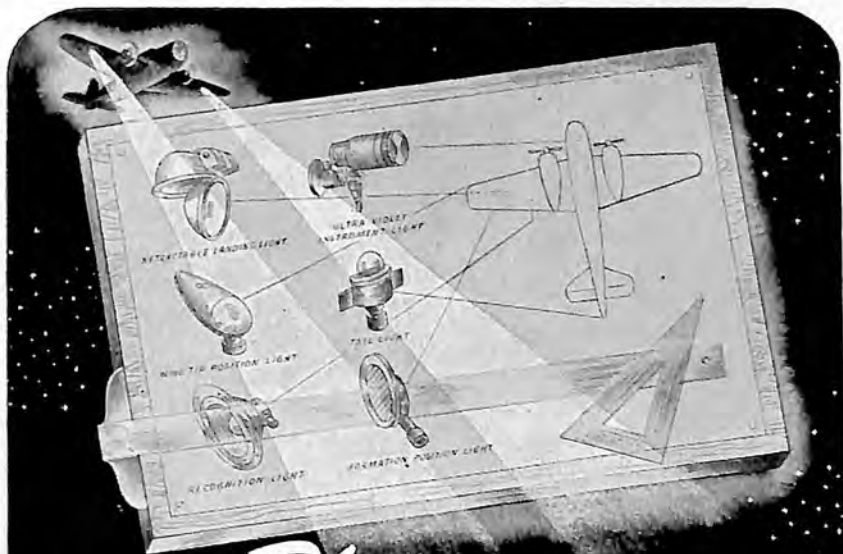

**GRIMES** *Plans* TO LIGHT THE WAY

Many aircraft lights designed and manufactured by Grimes for today's fighters and bombers will be flying the commercial air lanes of tomorrow. Even while concentrating 100% of our production on war items to make the present secure, we are developing lights that presage a brighter future.

"Proved under fire," Grimes lights can be depended upon to carry out every task assigned to them. As the designer and producer of more than 100 different types of aircraft lights now used on all fighting aircraft, Grimes looks with confidence to aviation's limitless peacetime tomorrow.

**Grimes Manufacturing Company, Urbana, Ohio**

*If it's Aircraft Lighting...*

**GRIMES**

*Designs and Makes it!*



**(Tail Wheel Assemblies) Continued**

Bendix Aviation Corp., Pacific Div.  
 Bendix Products Div. of Bendix Aviation Corp.  
 Colgate Aircraft Corp.  
 Firestone Aircraft Co.  
 General Aircraft Supply Corp.  
 The Heath Co.  
 Hockaday Aircraft Corp.  
 Hub Industries Inc.  
 Jack & Heintz, Inc.  
 Menasco Manufacturing Co.  
 Pacific Aviation, Inc.  
 Perry Metal Products Co.  
 Scott Aviation Corp.  
 Trans-American Airports Corp.  
 United States Rubber Co.  
 E. W. Wiggins Airways, Inc.

**LIFE SAVING EQUIPMENT**

Bendix Aviation Corp., Pacific Div.  
 Cluff Fabric Products  
 Firestone Aircraft Co.  
 The B. F. Goodrich Co.  
 Walter Kidde & Co., Inc.  
 Perry Metal Products Co. Inc.  
 Trans-American Airports Corp.  
 United States Rubber Co.

**LUBRICANTS**

The Atlantic Refining Co.  
 Babbitt Industrial Specialties Co.  
 Black Bear Co., Inc.  
 General Aircraft Supply Corp.  
 E. F. Houghton & Co.  
 Kendall Refining Co.  
 The Parker Appliance Co.  
 The Phoenix Oil Co.  
 Socony-Vacuum Oil Co., Inc.  
 Standard Oil Co. of California  
 D. A. Stuart Oil Co. Ltd.  
 The Texas Co.  
 Tide Water Associated Oil Co.  
 Valvoline Oil Co.  
 Wayne Chemical Products Co.

**MACHINE TOOLS**

Abrasive Machine Tool Co.  
 The Adams Co.  
 Aeronautical Mfg. Corp.  
 Aircraft Production Engineers

American Chain & Cable Co., Inc.  
 American Foundry Equipment Co.  
 American Stamping & Mfg. Co.  
 The American Tool Works Co.  
 Anderson Bros. Mfg. Co.  
 The Aro Equipment Corp.  
 Arter Grinding Machine Co.  
 Atlas Press Co.  
 The Avey Drilling Machine Co.  
 Axelson Manufacturing Co.  
 The Baird Machine Co.  
 Baker-Spiegel Co.  
 Bakewell Manufacturing Co.  
 Barber-Colman Co.  
 W. F. & John Barnes Co.  
 Barnes Drill Co.  
 Blacker Engineering Corp.  
 Boice-Crane Co.  
 Bryant Chucking Grinder Co.  
 Campbell Hdwe. & Supply Co.  
 The Cincinnati Lathe & Tool Co.  
 Cincinnati Milling & Grinding Machines, Inc.  
 The Cincinnati Shaper Co.  
 The Cleveland Punch & Shear Works Co.  
 Continental Machines Inc.  
 Couse Laboratories  
 Criterion Machine Works  
 The Denison Engineering Co.  
 Dix Manufacturing Co.  
 F & H Manufacturing Co.  
 The Fellows Gear Shaper Co.  
 Fitchburg Grinding Machine Corp.  
 Freedom Electric Co.  
 Gardner Machine Co.  
 General Aircraft Supply Corp.  
 General Manufacturing Co.  
 Giddings & Lewis Machine Tool Co.  
 Gisholt Machine Co.  
 Gleason Works  
 The Govro-Nelson Co.  
 The Hall Planetary Co.  
 Harris Seybold Potter Co., Seybold Div.  
 Ideal Commutator Dresser Co.  
 Jones & Lamson Machine Co.  
 Kent-Owens Machine Co.  
 Keystone Aircraft Products, Inc.  
 W. B. Knight Machinery Co.  
 L & J Press Corp.  
 Lane Wells Co.  
 Langelier Manufacturing Co.  
 Lincoln Engineering Co.  
 Like-Rollway Corp.  
 Lombard Governor Corp.

# MORRISON

## WIRE STITCHING

*Approved for secondary structures  
and non-structural assembly  
by U. S. Government*

### FOR THE FACTS

*This fabrication method has been thoroughly tested by one of America's leading aircraft laboratories and an official report prepared. For information, write for Bulletin No. 5.*

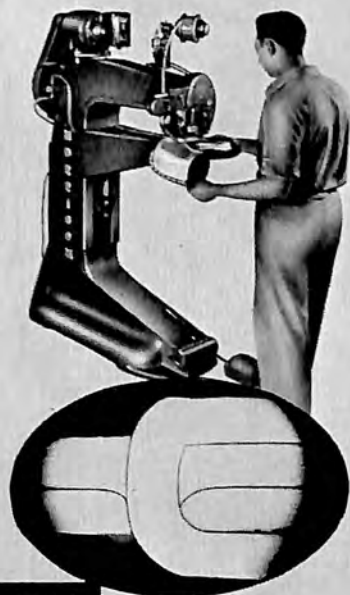

# MORRISON

PRODUCTS OF THE SEYBOLD DIVISION  
HARRIS-SEYBOLD-POTTER COMPANY  
DAYTON F7, OHIO

# STITCHERS

Photograph, magnified, of cross section of stitch driven thru two sheets of 24ST .040 aluminum by Model SJR Morrison Aircraft Stitcher.



**(Machine Tools) Continued**

Micromatic Hone Corp.  
 Modern Engineering Co., Inc.  
 National Automatic Tool Co., Inc.  
 Norton Co.  
 The Oilgear Co.  
 Onsrud Machine Works, Inc.  
 The Parker Appliance Co.  
 Perry Metal Products Co.  
 Pioneer Engineering & Manufacturing Co.  
 Pneumatic Drop Hammer Co.  
 Porter-Cable Machine Co.  
 Potter & Johnston Machine Co.  
 Pratt & Whitney, Div. Niles-Bement-Pond Co.  
 Proconier Safety Chuck Co.  
 W. A. Schuyler  
 The Sheffield Corp.  
 Special Machine Tool Engineering Works  
 Standard Machinery Co.  
 Stokerunit Corp.  
 The Taft Peirce Mfg. Co.  
 Taylor Manufacturing Co.  
 The Thompson Grinder Co.  
 The Tomkins Johnson Co.  
 Tubular Rivet and Stud Co.  
 U. S. Tool Co., Inc.  
 The United States Electrical Tool Co.  
 Van Norman Co.  
 Vinco Corp.  
 Wales-Strippit Corp.  
 Wickes Brothers

### MACHINERY & MACHINE PARTS

Ace Manufacturing Corp.  
 Acme Pattern & Tool Co., Inc.  
 The Acromark Co.  
 Aeronautical Products, Inc.  
 Aircraft Products Co.  
 Anderson Bros. Mfg. Co.  
 Baker-Spiegel Co.  
 W. F. & John Barnes Co.  
 The Carlyle Johnson Machine Co.  
 The E. W. Carpenter Mfg. Co.  
 The Cincinnati Lathe & Tool Co.  
 The Cincinnati Shaper Co.  
 The Cleveland Punch & Shear Works Co.  
 Colgate Aircraft Corp.  
 Criterion Machine Works  
 The Fellows Gear Shaper Co.  
 Garrison Machine Works, Inc.

Hardinge Brothers, Inc.  
 Harvey Machine Co., Inc.  
 The Hilliard Corp.  
 Kellogg Switchboard & Supply Co.  
 Kent-Owens Machine Co.  
 Keystone Aircraft Products, Inc.  
 Liberty Aircraft Products Corp.  
 Link-Belt Co.  
 Lombard Governor Corp.  
 Onsrud Machine Works, Inc.  
 Otto Aviation Corp.  
 Pannier Bros. Stamp Co.  
 Perry Metal Products Co. Inc.  
 Pioneer Engineering & Manufacturing Co.  
 Potter & Johnston Machine Co.  
 H. P. Preis Engraving Machine Co.  
 Reeves Pulley Co.  
 The Sheffield Corp.  
 Special Machine Tool Engineering Works  
 Standard Machinery Co.  
 Sutorbilt Corp.  
 The Tannewitz Works  
 Taylor Manufacturing Co.  
 U. S. Tool Co., Inc.  
 Verson Allsteel Press Co.  
 Wickes Brothers  
 Wittek Manufacturing Co.  
 N. A. Woodworth Co.

### MANIFOLDS

Aircraft Components, Inc.  
 Aircraft Products, Inc.  
 All American Aircraft Products, Inc.  
 American Tube Bending Co., Inc.  
 Angelus Steel Treating Co.  
 B. H. Aircraft Co.  
 The Brewer-Titchener Corp.  
 Chase Brass & Copper Co.  
 Guiberson Diesel Engine Co.  
 Keystone Aircraft Products, Inc.  
 New Brunswick Die Molding Div. of Universal Plastics Co.  
 Perry Metal Products Co. Inc.  
 Pollak Manufacturing Co.  
 Roberts & Mander Stove Co.  
 Taylorcraft Aviation Corp.  
 Trans-American Airports Corp.  
 Tyler Fixture Corp.

### OIL SEALS

American Hammered Piston Ring Div. Koppers Co.



# Extra Production

## WITHOUT ADDITIONAL MANPOWER

Illustrated here are various phases of aircraft production which no longer need be highly vulnerable to manpower shortages. On jobs like these, Onsrud machines and techniques have revolutionized old ideas of production per man hour.

The high cutter speeds and fast feeds featured in these tools not only get more work done in less time, but also improve the quality of that work. Tremendous savings of time and material have been possible on such operations as routing and drilling of stacked flat sheets; grinding; profile, groove and straddle milling as well as tapering and twist cutting of spar beams and similar long parts; bevel milling of flat sheets; and portable routing of formed parts.

New applications are constantly being found for Onsrud methods and machines. Production men can get invaluable help on difficult problems from our engineers. They place at your disposal data and information secured through Onsrud's pioneering in the field of high speed, high cycle, and air turbine machining. Make a point of learning all about Onsrud products soon.

### ONSRUD MACHINE WORKS, Inc.

3900-3932 Palmer Street, Chicago 47, Illinois  
Sales Offices in all Principal Cities



HIGH CYCLE AND AIR TURBINE TOOLS AND MACHINES  
FOR AIRCRAFT NONFERROUS METALWORKING

**(Oil Seals) Continued**

Armstrong Cork Co.  
 Arrowhead Rubber Co.  
 Associated Rubber Products Co.  
 Babbitt Industrial Specialties Co.  
 The Bowling Green Rubber Co.  
 Burlington Mills, Inc.  
 Clifford Manufacturing Co.  
 The Felters Co.  
 Firestone Aircraft Co.  
 The Garlock  
 The B. F. Goodrich Co.  
 E. F. Houghton & Co.  
 Johns-Manville Sales Corp.  
 Linear Packing & Rubber Co., Inc.  
 Perry Metal Products Co. Inc.  
 Radiator Specialty Co.  
 James H. Rhodes & Co.  
 Special Machine Tool Engineering  
 Works  
 Trans-American Airports Corp.

**PANELS**

The Acromark Co.  
 Aero Parts Manufacturing Co.  
 Allied Aviation Corp.  
 American Central Manufacturing  
 Corp.  
 Colgate Aircraft Corp.  
 Detroit Sheet Metal Works  
 Duramold Div. of Fairchild Engine &  
 Airplane Corp.  
 Firestone Aircraft Co.  
 The Formica Insulation Co.  
 The B. F. Goodrich Co.  
 King Plastics Corp.  
 Models, Inc.  
 The Murray Corp. of America  
 Roberts & Mander Stove Co.  
 Rohr Aircraft Corp.  
 Special Machine Tool Engineering  
 Works  
 Taylorcraft Aviation Corp.  
 Technical Ply-Woods  
 Trans-American Airports Corp.  
 United States Plywood Corp.  
 Weber Showcase & Fixture Co., Inc.

**PARACHUTES &  
PARTS**

Airchox Co., Div. of Joyce Aviation  
 Inc.  
 Bokelman Co., Inc.  
 The Brewer-Titchener Corp.

Chicago Metal Hose Corp.  
 Eagle Parachute Corp.  
 Firestone Aircraft Co.  
 Fox Co.  
 Hayes Manufacturing Corp.  
 Hope Webbing Co.  
 Pioneer Parachute Co., Inc.  
 Switlik Parachute Co.  
 Trans-American Airports Corp.  
 United-Carr Fastener Corp.  
 The Washburn Co.

**PARTS (AIRCRAFT)**

Ace Manufacturing Corp.  
 The Acromark Co.  
 Adel Precision Products Corp.  
 Aerco Corp.  
 Aero Supply Mfg. Co., Inc.  
 Aero Trades Co.  
 Aeronautical Products, Inc.  
 Agawam Aircraft Products, Inc.  
 Aircraft & Marine Specialty Co.  
 Aircraft Containers Co.  
 Allied Aviation Corp.  
 Aluminum Industries, Inc.  
 American Screw Products  
 Ampco Metal, Inc.  
 Celanese Celluloid Corp.  
 The Centerless Grinding Co., Inc.  
 Chase Brass & Copper Co.  
 Clifford Manufacturing Co.  
 Colgate Aircraft Corp.  
 Continental-Diamond Fibre Co.  
 Criterion Machine Works  
 Firestone Aircraft Co.  
 General Aircraft Supply Corp.  
 Grand Rapids Industries, Inc.  
 The Hardware Specialties Mfg. Co.  
 Harvey Machine Co., Inc.  
 The Heath Co.  
 Hoof Products Co.  
 Hope Webbing Co.  
 Hyland Machine Co.  
 Johns-Manville Sales Corp.  
 Liberty Aircraft Products Corp.  
 McQuay Inc.  
 Major Aircraft Foundry  
 The Marquette Metal Products Co.  
 National Machine Products  
 Neu-Bart Stamping & Mfg. Co.  
 Otto Aviation Corp.  
 The Permold Co.  
 Perry Metal Products Co. Inc.  
 Pollak Manufacturing Co.  
 Remington Rand Inc.

## 'Chutin for keeps!

Making parachutes is our business, as it was yesterday, and will be tomorrow. Switlik engineers are not just 'duration' trained — they're qualified through years of experience!\* As America's largest pre-Pearl Harbor manufacturer of parachutes, Switlik's wartime efforts have won a Star for our prized Army-Navy "E" Award. ☆ ☆ ☆ Tomorrow points the way to continued Switlik leadership in the parachute field... making 'chutes for keeps!

*\*For your post-war parachute problems, whether to 'chute one pound or one ton, see Switlik for safety.*



**SWITLIK PARACHUTE COMPANY**

Trenton, New Jersey



## AIRCRAFT RADIO CORPORATION



Designers and Manufacturers of Radio Equipment for Army and Navy Airplanes



BOONTON, N. J.  
U. S. A.



## TRUSTWORTHY

Since 1916 we've built the best props we know how to build. And that we do know how is expressed in a recent letter from a flier: "... I could get quicker delivery, but I'd rather wait for a Hartzell."

**HARTZELL**  
**PROPELLER CO.**  
PIQUA, OHIO, U. S. A.

**(Parts—Aircraft) Continued**

James H. Rhodes & Co.  
 Roberts & Mander Stove Co.  
 Rohlm Manufacturing Co., Inc.  
 Rohr Aircraft Corp.  
 Special Machine Tool Engineering Works  
 The Taft Peirce Mfg. Co.  
 Taylorcraft Aviation Corp.  
 Thompson Products, Inc.  
 Timm Aircraft Corp.  
 Trans-American Airports Corp.  
 Tyler Fixture Corp.  
 Waldes Koh-I-Noor, Inc.  
 Warner Manufacturing Co.  
 Westinghouse Electric & Manufacturing Co.  
 E. W. Wiggins Airways, Inc.

**Aluminum Parts**

A & F Aluminum Products Co.  
 Ace Manufacturing Corp.  
 The Acromark Co.  
 Adel Precision Products Corp.  
 Aero Parts Manufacturing Co.  
 Aero Supply Mfg. Co. Inc.  
 Aero Trades Co.  
 Aeronautical Mfg. Corp.  
 Aeronautical Products, Inc.  
 Aeroproducts Manufacturing Co.  
 Aeroquip Corp.  
 Agawam Aircraft Products, Inc.  
 Air Associates, Inc.  
 Aircraft & Marine Specialty Co.  
 Aircraft Containers Co.  
 Aircraft Engineering Products, Inc.  
 Aircraft Parts Development Corp.  
 Aircraft Products Co.  
 Aircraft Specialties Co.  
 Airsealand Aircraft Corp.  
 All American Aircraft Products, Inc.  
 Alloys Foundry Inc.  
 Aluminum Company of America  
 Aluminum Industries, Inc.  
 Aluminum Ladder Co.  
 American Armament Corp.  
 American Screw Products  
 American Stamping & Mfg. Co.  
 American Tube Bending Co., Inc.  
 Angelus Steel Treating Co.  
 The Apex Tool Co., Inc.  
 Armstrong Cork Co.  
 Arnolt Motor Co.  
 Associated Foundries & Manufacturers, Inc.

Atlantic Diesel Corp.  
 Automotive Rubber Co.  
 Aviquipo Manufacturing Corp.  
 Bardwell & McAlister, Inc.  
 Bellanca Aircraft Corp.  
 Breeze Corporations, Inc.  
 Chase Brass & Copper Co.  
 Colgate Aircraft Corp.  
 Continental Can Co., Inc.  
 Criterion Machine Works  
 Dahlstrom Metallic Door Co.  
 Edo Aircraft Corp.  
 Firestone Aircraft Co.  
 G & H Tool & Manufacturing Co.  
 General Bronze Corp.  
 Gilfillan Bros. Inc.  
 The Hardware Specialties Mfg. Co.  
 Hartford Machine Screw Co.  
 Harvey Machine Co., Inc.  
 Hockaday Aircraft Corp.  
 Hoof Products Co.  
 Hyland Machine Co.  
 The Imperial Brass Manufacturing Co.  
 Kent-Owens Machine Co.  
 Keystone Aircraft Products, Inc.  
 Liberty Aircraft Products Corp.  
 H. K. Lorentzen, Inc.  
 The M B Manufacturing Co. Inc.  
 Major Aircraft Foundry  
 Mercury Aircraft Inc.  
 Moore-Eastwood & Co.  
 The Murray Corp. of America  
 National Machine Products  
 New Brunswick Die Molding Div. of  
 Universal Plastics Corp.  
 The Newton-New Haven Co.  
 Otto Aviation Corp.  
 The Permold Co.  
 Perry Metal Products Co. Inc.  
 Pollak Manufacturing Co.  
 Revere Copper and Brass Inc.  
 Reynolds Metals Co.  
 Ritter Company, Inc.  
 Roberts & Mander Stove Co.  
 Rohlm Manufacturing Co., Inc.  
 Southern California Airparts, Div. of  
 Jarvis Manufacturing Co.  
 Special Machine Tool Engineering Works  
 The Taft Peirce Mfg. Co.  
 Taylorcraft Aviation Corp.  
 Teicher Manufacturing Corp.  
 Timm Aircraft Corp.  
 Trans-American Airports Corp.  
 Tube Turns, Inc.

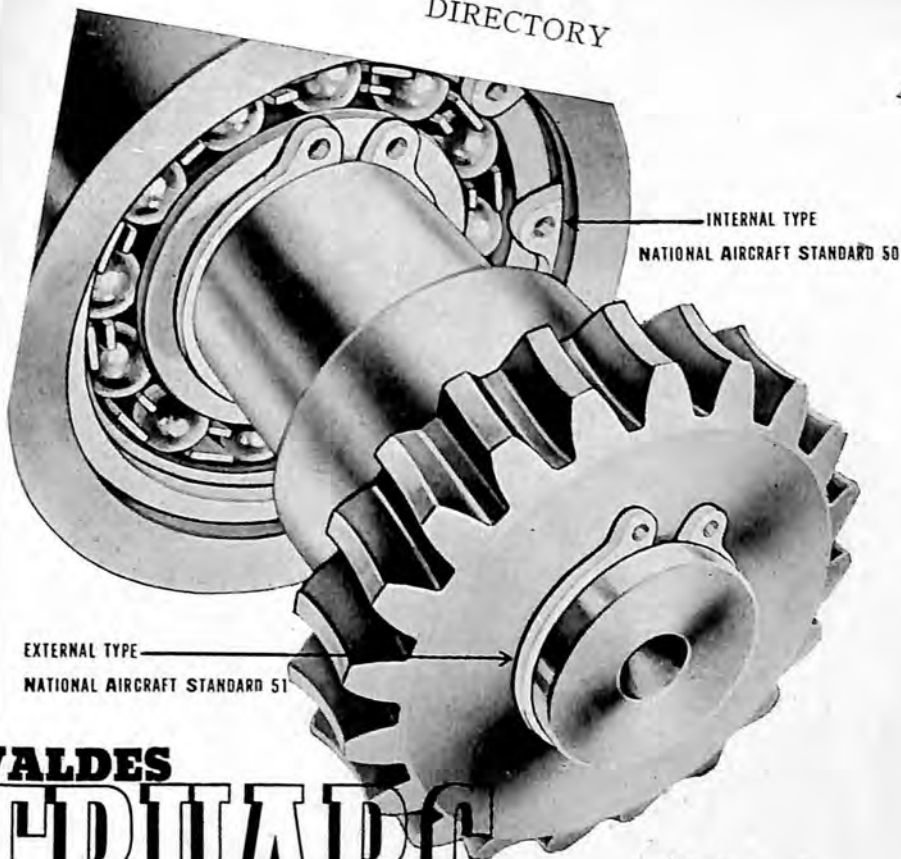

# WALDES TRUARC RETAINING RING

U. S. PATENT  
RE 18144

● Waldes Truarc presents a significant advance in retaining rings.

It spreads or contracts without distortion; retaining its perfectly fitting circular contour.

For thrust-load fixing, shaft and housing applications, Waldes Truarc provides dis-

tinct advantages over nuts and bolts or wedges and washers. It reduces dimension and weight, saves material, cuts manufacturing time...simplifies assembly, and dis-assembly.

On request, we will gladly furnish samples and full data for your tests.

SOLE MANUFACTURERS AND LICENSEES IN U. S. A.

**WALDES KOH-I-NOOR-INC · LONG ISLAND CITY, N. Y.**

CANADIAN REPRESENTATIVES: PRENCO  
PROGRESSIVE AND ENGINEERING CORPORATION, LTD.  
72-74 STAFFORD ST., TORONTO





**(Aluminum Parts) Continued**

Union Aircraft Products Corp.  
 Vide Products  
 Warner Manufacturing Co.  
 The Wellman Bronze & Aluminum Co.  
 Westinghouse Electric & Manufacturing Co.  
 E. W. Wiggins Airways, Inc.

**Cork Parts**

Aero Supply Mfg. Co., Inc.  
 Armstrong Cork Co.  
 Automatic Electrical Devices Co.

**Felt Parts**

Armstrong Cork Co.  
 Automatic Electrical Devices Co.  
 Automotive Rubber Co.  
 Burlington Mills, Inc.  
 The Felters Co.  
 James H. Rhodes & Co.  
 Seaman Paper Co.

**Fibre Parts**

Allied Aviation Corp.  
 Armstrong Cork Co.  
 Automatic Electrical Devices Co.  
 Automotive Rubber Co.  
 Edward F. Aymond Co.  
 Continental-Diamond Fibre Co.  
 Owens-Corning Fiberglas Corp.  
 Spaulding Fibre Co., Inc.  
 Trans-American Airports Corp.

**Leather Parts**

Cleveland Tanning Co.  
 Graton & Knight Co.  
 Hamilton Wade Co.  
 E. F. Houghton & Co.  
 The Lackawanna Leather Co.  
 Radel Leather Mfg. Co.  
 United States Rubber Co.

**Magnesium Parts**

Aeroproducts Manufacturing Co.  
 Agawam Aircraft Products, Inc.  
 Aircraft Engineering Products, Inc.  
 Aircraft Products Co.  
 Airsealand Aircraft, Inc.  
 Alloys Foundry Inc.

Aluminum Company of America  
 Aluminum Ladder Co.  
 American Magnesium Corp.  
 The Apex Tool Co., Inc.  
 Arnolt Motor Co.  
 Associated Foundries & Manufacturers, Inc.  
 Atlantic Diesel Corp.  
 Aviquipo Manufacturing Corp.  
 The Dow Chemical Co.  
 The Hardware Specialties Mfg. Co.  
 The M B Manufacturing Co. Inc.  
 Mercury Aircraft Inc.  
 National Machine Products  
 The Newton-New Haven Co.  
 The Ohio Piston Co.  
 Ohlsson & Rice Manufacturing Co.  
 Revere Copper and Brass Inc.  
 Special Machine Tool Engineering Works  
 Warner Manufacturing Co.

**Plastic Parts**

Aero Supply Mfg. Co. Inc.  
 Aeroproducts Manufacturing Co.  
 Aircraft Parts Development Corp.  
 Allied Aviation Corp.  
 American Phenolic Corp.  
 Associated Foundries & Manufacturers, Inc.  
 Aviquipo Manufacturing Corp.  
 Edward F. Aymond Co.  
 Bellanca Aircraft Corp.  
 Capac Manufacturing Co.  
 Celanese Celluloid Corp.  
 Columbus Plastic Products, Inc.  
 Commercial Plastics Co.  
 Continental Can Co., Inc.  
 Continental-Diamond Fibre Co.  
 Duramold Div. of Fairchild Engine & Airplane Corp.  
 Firestone Aircraft Co.  
 The Electric Auto-Lite Co.  
 The Formica Insulation Co.  
 General Aircraft Supply Corp.  
 General Electric Co.  
 The B. F. Goodrich Co.  
 Haskelite Manufacturing Corp.  
 The Heath Co.  
 Kilgen Aircraft, Div. of Kilgen Organ Co.  
 King Plastics Corp.  
 Pierce Plastics, Inc.  
 Plastic Manufacturers, Inc.  
 Printloid Inc.

## *Specializing in*

Aluminum and Magnesium castings, Alloys Foundry, Inc., offers superior quality and service to aircraft manufacturers. Facilities include physical, metallurgical and X-ray inspection; sand-casting; molding; heat treatment to specifications, and engineering service if required.



Typical Magnesium and Aluminum Castings produced for various aircraft manufacturers by Alloys Foundry, Inc.

*Inquiries invited by wire or mail*

**ALLOYS FOUNDRY, INCORPORATED**

530 EAST 2ND STREET

**WICHITA, KANSAS**

**(Plastic Parts) Continued**

Rohm & Haas Co.  
 Snapvent Co.  
 Spaulding Fibre Co., Inc.  
 Success Plastics Recovery Works  
 Taylor Manufacturing Co.  
 Trans-American Airports Corp.  
 United States Plywood Corp.  
 Victor Metal Products Corp.  
 Weber Showcase & Fixture Co., Inc.  
 Westinghouse Electric & Manufacturing Co.

**Plywood Parts**

All American Aircraft Products, Inc.  
 Allied Aviation Corp.  
 American Plywood Corp.  
 Aviquipo Manufacturing Corp.  
 Bellanca Aircraft Corp.  
 Duramold Div. of Fairchild Engine & Airplane Corp.  
 General Aircraft Supply Corp.  
 General Electric Co.  
 Grand Rapids Industries, Inc.  
 Haskelite Manufacturing Corp.  
 The Heath Co.  
 Indiana Veneer & Panel Co.  
 Keystone Aircraft Products, Inc.  
 Kilgen Aircraft, Div. of Kilgen Organ Co.  
 McQuay Inc.  
 Marine-Air Research Corp.  
 Skydyne, Inc.  
 Taylor Manufacturing Co.  
 Taylorcraft Aviation Corp.  
 Technical Ply-Woods  
 Trans-American Airports Corp.  
 United States Plywood Corp.  
 Weber Showcase & Fixture Co., Inc.

**Rubber Parts**

Adel Precision Products Corp.  
 Armstrong Cork Co.  
 Arrowhead Rubber Co.  
 Associated Rubber Products Co.  
 Atlantic India Rubber Works, Inc.  
 Automotive Rubber Co.  
 The Bowling Green Rubber Co.  
 Connecticut Hard Rubber Co.  
 Firestone Aircraft Co.  
 The Garlock Packing Co.  
 General Aircraft Supply Corp.  
 The B. F. Goodrich Co.  
 Linear Packing & Rubber Co. Inc.

Taylor Manufacturing Co.  
 Trans-American Airports Corp.  
 United States Rubber Co.

**Steel Parts**

Ace Manufacturing Corp.  
 Aero Parts Manufacturing Co.  
 Aero Supply Mfg. Co. Inc.  
 Aeronautical Mfg. Corp.  
 Aeronautical Products, Inc.  
 Aeroproducs Manufacturing Co.  
 Aeroquip Corp.  
 Agawam Aircraft Products, Inc.  
 Air Associates, Inc.  
 Airco Tool Co.  
 Aircraft & Marine Specialty Co.  
 Aircraft Containers Co.  
 Aircraft Engineering Products, Inc.  
 Aircraft Hardware Mfg. Co.  
 Aircraft Parts Development Corp.  
 Aircraft Products Co.  
 Aircraft Products, Inc.  
 Aircraft Specialties Co.  
 Airsealand Aircraft, Inc.  
 American Armament Corp.  
 American Screw Products  
 American Stamping & Mfg. Co.  
 American Tube Bending Co., Inc.  
 Angelus Steel Treating Co.  
 The Apex Tool Co., Inc.  
 Arnolt Motor Co.  
 Associated Foundries & Manufacturers, Inc.  
 Atlantic Diesel Corp.  
 Automatic Electrical Devices Co.  
 Aviquipo Manufacturing Corp.  
 Baltic Metal Products Co.  
 Chas. W. Carll Sons  
 Carnegie-Illinois Steel Corp.  
 The E. W. Carpenter Mfg. Co.  
 Colgate Aircraft Corp.  
 Criterion Machine Works  
 Crucible Steel Company of America  
 Dahlstrom Metallic Door Co.  
 Gilfillan Bros. Inc.  
 Hartford Machine Screw Co.  
 Harvey Machine Co., Inc.  
 Heyman Mfg. Co.  
 Highbridge-International Co.  
 Hockaday Aircraft Corp.  
 Hoof Products Co.  
 Hyland Machine Co.  
 Keystone Aircraft Products, Inc.  
 Kropp Forge Aviation Co.  
 Liberty Aircraft Products Corp.

**WEBER'S manufacturing facilities solve aircraft production problems!**



**W**EBER'S production short cut based on original research . . . sound engineering and quality standards of workmanship meet aircraft industries' varied production requirements. We are completely equipped to solve your special manufacturing problems in metal, wood or glass. Write or wire today for the specific information that interests you.

**WEBER** FACILITIES & EXPERIENCE  
 "WORKING FOR VICTORY"

WEBER SHOWCASE & FIXTURE CO. INC., 5700 AVALON BLVD., LOS ANGELES, CALIF. • EST. 1898

**(Steel Parts) Continued**

McQuay Inc.  
 The M B Manufacturing Co. Inc.  
 Moore-Eastwood & Co.  
 The Murray Corp. of America  
 National Machine Products  
 Ohlsson & Rice Manufacturing Co.  
 Perry Metal Products Co. Inc.  
 Pittsburgh Steel Co.  
 Pollak Manufacturing Co.  
 Ritter Company, Inc.  
 Roberts & Mander Stove Co.  
 SAE Steels  
 Sharon Steel Corp.  
 Special Machine Tool Engineering  
 Works  
 Summerill Tubing Co.  
 The Taft Peirce Mfg. Co.  
 Taylorcraft Aviation Corp.  
 Thompson Products, Inc.  
 Trans-American Airports Corp.  
 Tube Turns, Inc.  
 Tyler Fixture Corp.  
 Vide Products  
 Waldes Koh-I-Noor, Inc.  
 Warner Manufacturing Co.  
 E. W. Wiggins Airways, Inc.

**Synthetic Parts**

Adel Precision Products Corp.  
 Aeroquip Corp.  
 American Phenolic Corp.  
 Armstrong Cork Co.  
 Associated Rubber Products Co.  
 Automotive Rubber Co.  
 Aviquipo Manufacturing Corp.  
 Edward F. Aymond Co.  
 The Bowling Green Rubber Co.  
 Burlington Mills, Inc.  
 Connecticut Hard Rubber Co.  
 General Electric Co.  
 The B. F. Goodrich Co.  
 The Hardware Specialties Mfg. Co.  
 Linear Packing & Rubber Co., Inc.  
 The Parker Appliance Co.  
 Perry Metal Products Co. Inc.  
 Resistoflex Corp.  
 Taylor Manufacturing Co.  
 Trans-American Airports Corp.

**Wood Parts**

Aero Trades Co.  
 Aircraft Lumber Co.  
 Allied Aviation Corp.

American Plywood Corp.  
 Grand Rapids Industries, Inc.  
 The Heath Co.  
 Indigena Veneer & Panel Co.  
 Kilgen Aircraft, Div. of Kilgen Organ  
 Co.  
 Marine-Air Research Corp.  
 J. V. G. Posey & Co.  
 Taylorcraft Aviation Corp.  
 Technical Ply-Woods  
 Trans-American Airports Corp.  
 E. W. Wiggins Airways, Inc.

**PLASTICS**

Aviquipo Manufacturing Corp.  
 Avondale Chemical Co.  
 Burlington Mills, Inc.  
 Capac Manufacturing Co.  
 Catalin Corp.  
 Celanese Celluloid Corp.  
 Cinch Manufacturing Corp.  
 Columbus Plastic Products, Inc.  
 Commercial Plastics Co.  
 Continental Can Co., Inc.  
 Continental-Diamond Fibre Co.  
 The Formica Insulation Co.  
 General Aircraft Supply Corp.  
 The B. F. Goodrich Co.  
 Irvington Varnish & Insulator Co.  
 Kellogg Switchboard & Supply Co.  
 Keyes Fibre Co.  
 King Plastics Corp.  
 Manufacturers Chemical Corp.  
 Ohlsson & Rice Manufacturing Co.  
 Pierce Plastics, Inc.  
 Plaskon Div., Libbey-Owens-Ford  
 Glass Co.  
 Plastic Manufacturers, Inc.  
 Ritter Company, Inc.  
 Spaulding Fibre Co., Inc.  
 Success Plastics Recovery Works  
 Taylor Manufacturing Co.  
 Tennessee Eastman Corp.  
 United States Plywood Corp.  
 Veeder-Root Inc.  
 Victor Metal Products Corp.

**PRIMERS (ENGINE)**

Acme White Lead & Color Works  
 Aircraft Instrument Service, Inc.  
 Associated Foundries & Manufac-  
 turers, Inc.  
 Avondale Chemical Co.  
 The Dole Valve Co.



**STRONG AS A FEATHER . . .**

One of nature's masterpieces, the feather, has a weight-strength ratio that remains a challenge to designers. And, of course, the feather's spine is a tube.

Here at Summerill we produce seamless steel tubing, much of which is used in the construction of our birds of war. Not only do we make standard aircraft rounds, streamlines, ovals and squares, but also tapered, swaged and upset sections for special applications. We are always ready to cooperate with aircraft engineers and designers in the solution of problems involving new or special tubing applications.



**SUMMERILL TUBING COMPANY**

Affiliated with EDGAR T. WARD'S SONS CO.

and COLUMBIA STEEL & SHAFTING CO.



**BRIDGEPORT . MONTGOMERY COUNTY . PENNSYLVANIA**



**(Primers) (Engine) Continued**

General Aircraft Supply Corp.  
 General Controls Co.  
 The Imperial Brass Manufacturing Co.  
 Kohler Aircraft Products Co.  
 The Parker Appliance Co.  
 Perry Metal Products Co. Inc.  
 Standard Oil Company of California  
 Trans-American Airports Corp.

### PROPELLERS & PROPELLER PARTS

Adel Precision Products Corp.  
 Aero Engineering Corp.  
 Aero Supply Mfg. Co. Inc.  
 Aeronautical Products, Inc.  
 Aeroproducs Div., General Motors Corp.  
 Air Craftsmen, Inc.  
 Aircraft Engineering Products, Inc.  
 American Propeller Corp.  
 American Tube Bending Co., Inc.  
 The Aro Equipment Corp.  
 Atlantic Diesel Corp.  
 Bartlett Hayward Div. Koppers Co.  
 Curtiss-Wright Corp., Propeller Div.  
 The Denison Engineering Co.  
 The Formica Insulation Co.  
 General Aircraft Supply Corp.  
 Hamilton Standard Propellers  
 Hartford Machine Screw Co.  
 Hartzell Propeller Co.  
 The Marquette Metal Products Co.  
 Models, Inc.  
 The Ohio Piston Co.  
 Perry Metal Products Co. Inc.  
 Remington Rand Inc.  
 Ritter Company, Inc.  
 Sensenich Brothers  
 Special Machine Tool Engineering Works  
 The Taft Peirce Mfg. Co.  
 Thompson Products, Inc.  
 Trans-American Airports Corp.  
 Vinco Corp.  
 Warner Manufacturing Co.

### PULLEYS AND FANLEADS

Continental-Diamond Fibre Co.  
 The Formica Insulation Co.  
 General Aircraft Supply Corp.  
 King Plastics Corp.

Perry Metal Products Co. Inc.  
 Plastic Manufacturers, Inc.  
 Trans-American Airports Corp.

### PUMPS

Adel Precision Products Corp.  
 Aero Supply Mfg. Co. Inc.  
 Air Associates, Inc.  
 Aircraft Engineering Products, Inc.  
 Aircraft Products Co.  
 Allis-Chalmers Mfg. Co.  
 The Aro Equipment Corp.  
 B. H. Aircraft Co.  
 Blackmer Pump Co.  
 Chandler-Evans Corp.  
 Clifford Manufacturing Co.  
 Ralph C. Coxhead Corp.  
 The Denison Engineering Co.  
 Eclipse-Pioneer Div., Bendix Aviation Corp.  
 Gilfillan Bros. Inc.  
 Granberg Equipment Inc.  
 Hub Industries Inc.  
 Jack & Heintz, Inc.  
 Lincoln Engineering Co.  
 The Marquette Metal Products Co.  
 Nash Engineering Co.  
 The Ohio Piston Co.  
 Pacific Aviation, Inc.  
 Perry Metal Products Co. Inc.  
 Pesco Products Co.  
 Pioneer Engineering & Manufacturing Co.  
 Geo. D. Roper Corp.  
 Sutorbilt Corp.  
 Trans-American Airports Corp.  
 United Aircraft Products, Inc.

### RADIATORS

Airesearch Manufacturing Co.  
 Clifford Manufacturing Co.  
 Drayer and Hanson, Inc.  
 The G & O Manufacturing Co.  
 St. Louis Radio Engineering Co.  
 Trans-American Airports Corp.  
 United Aircraft Products, Inc.

### RADIO ACCESSORIES & EQUIPMENT

Ace Manufacturing Corp.  
 Aeronautical Radio Mfg. Co.  
 Aircraft Accessories Corp.  
 Aircraft Instrument Service, Inc.

# *Right* ON THE NOSE OF THE FAIRCHILD PT-19

Sensenich propellers are *right* on the nose of the Fairchild PT-19...and other famous Army and Navy planes. They're designed *right*...built *right*...by the world's largest manufacturers of wood propellers.



**RIGHT ON THE NOSE OF THESE  
FAMOUS ARMY AND NAVY PLANES**

- Taylorcraft L-2A • Aerona L-3B
- Stinson L-5 • Piper L-4A, HE-1
- Fairchild PT-19, PT-23, PT-26,  
C-61 • Ryan PT-22, PT-25 •
- Boeing-Stearman N2S-3, N2S-5
- Cessna AT-17

**SENENICH BROTHERS  
AIRCRAFT PROPELLERS**



Adjacent to Lancaster Municipal Airport, Lilitz, Pa. • West Coast Branch, Glendale, Calif.

**(Radio Accessories & Equipment)***Continued*

Airdesign & Fabrication, Inc.  
 Aladdin Radio Industries, Inc.  
 Belmont Radio Corp.  
 Bendix Aviation Corp., Pacific Div.  
 Bendix Radio Div. of Bendix Aviation Corp.  
 Chicago Metal Hose Corp.  
 Clifford Manufacturing Co.  
 Consolidated Radio Products Co.  
 The R. W. Cramer Co., Inc.  
 Dahlstrom Metallic Door Co.  
 Drake Manufacturing Co.  
 Federal Telephone & Radio Corp.  
 Friez Instrument, Div. of Bendix Aviation Corp.  
 L. M. Gear Co.  
 General Armature Corp.  
 General Electric Co.  
 The Hallicrafters Co.  
 Harvey Machine Co., Inc.  
 Harvey Radiolaboratories, Inc.  
 Harvey-Wells Communications Inc.  
 The Heath Co.  
 Kellogg Switchboard & Supply Co.  
 Kulka Electric Mfg. Co., Inc.  
 H. K. Lorentzen, Inc.  
 P. R. Mallory & Co., Inc.  
 Mu-Switch Corp.  
 Operadio Manufacturing Co.  
 Otto Aviation Corp.  
 Owens-Corning Fiberglas Corp.  
 Permoflux Corp.  
 Perry Metal Products Co., Inc.  
 Philco Corp.  
 Plastic Manufacturers, Inc.  
 Radio Receptor Co. Inc.  
 Remington Rand Inc.  
 St. Louis Radio Engineering Co.  
 Shure Brothers  
 J. Earl Smith  
 Sperry Gyroscope Co., Inc.  
 Stoddart Aircraft Radio Co.  
 Thordarson Electric Mfg. Co.  
 Trans-American Airports Corp.  
 United-Carr Fastener Corp.  
 United Transformer Co.  
 Ward Leonard Electric Co.

**RADIO COMPASSES**

Aeronautical Radio Mfg. Co.  
 Aeroproducts Manufacturing Co.  
 Aircraft Instrument Service, Inc.  
 Belmont Radio Corp.

Bendix Radio Div. of Bendix Aviation Corp.  
 The W. W. Boes Co.  
 L. M. Gear Co.  
 General Aircraft Supply Corp.  
 Harvey Machine Co., Inc.  
 Harvey-Wells Communications Inc.  
 Philco Corp.  
 St. Louis Radio Engineering Co.  
 J. Earl Smith  
 Sperry-Gyroscope Co., Inc.  
 Trans-American Airports Corp.

**RADIOS**

Aeronautical Radio Mfg. Co.  
 Air Associates, Inc.  
 Air Communications, Inc.  
 Aircraft Instrument Service, Inc.  
 Aircraft Radio Corp.  
 Rex Bassett, Inc.  
 Belmont Radio Corp.  
 Bendix Aviation Corp., Pacific Div.  
 Bendix Radio Div. of Bendix Aviation Corp.  
 The W. W. Boes Co.  
 Clifford Manufacturing Co.  
 Communications Co., Inc.  
 L. M. Gear Co.  
 General Aircraft Supply Corp.  
 Gilfillan Bros., Inc.  
 Harvey Machine Co., Inc.  
 Harvey Radiolaboratories, Inc.  
 Harvey-Wells Communications Inc.  
 The Heath Co.  
 Islip Radio Manufacturing Corp.  
 Philco Corp.  
 Radio Receptor Co. Inc.  
 St. Louis Radio Engineering Co.  
 J. Earl Smith  
 Stoddart Aircraft Radio Co.  
 Trans-American Airports Corp.  
 Westinghouse Electric & Manufacturing Co.

**RIVETS**

Aluminum Company of America  
 Bethlehem Steel Co.  
 Chase Brass & Copper Co.  
 General Aircraft Supply Corp.  
 The B. F. Goodrich Co.  
 The National Screw & Mfg. Co.  
 Otto Aviation Corp.  
 Perry Metal Products Co., Inc.  
 Republic Steel Corp.

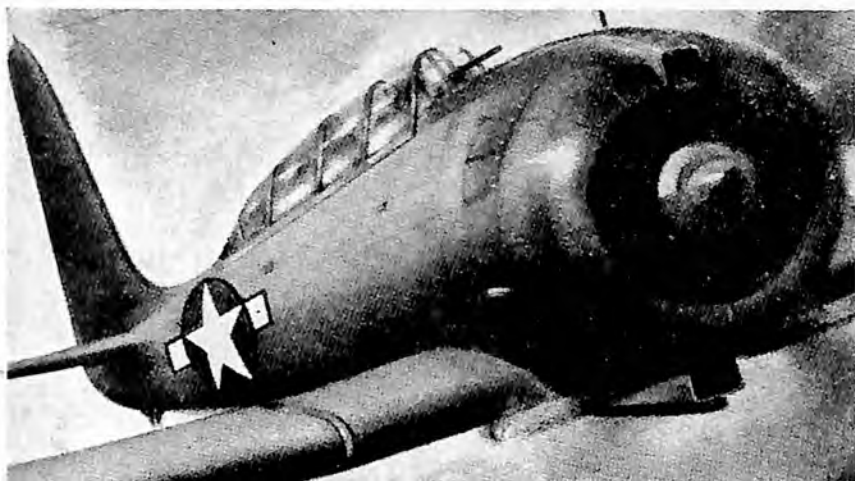

## TOUGH CUSTOMERS!

As the enemy often has discovered to his cost, planes marked with the star of Uncle Sam are pretty tough customers to argue with up there in the sky. That's partly because the old gentleman with the beard and the star-spangled hat knows how to be tough in buying the equipment that goes into these planes.

In engineering, materials and workmanship, he insists on the best. And in the electronic equipment produced here at Belmont, we see that he gets it.

This experience in pleasing the world's most critical customer will, one day, be turned full force to the production of radio and allied equipment that will be equally sure to please millions of customers all over the world Belmont Radio Corp., 5927 W. Dickens Ave., Chicago 39, Ill.

 **Belmont Radio**  
TELEVISION ★ FM ★ ELECTRONICS

**(Rivets) Continued**

Russell, Burdsall & Ward Bolt & Nut Co.  
 Edwin B. Stimpson Co., Inc.  
 Trans-American Airports Corp.  
 Tubular Rivet & Stud Co.

**SAFETY BELTS**

Airchox Co., Div. of Joyce Aviation Inc.  
 Bokelman Co., Inc.  
 General Aircraft Supply Corp.  
 Hope Webbing Co.  
 Mine Safety Appliances Co.  
 Perry Metal Products Co., Inc.  
 Trans-American Airports Corp.  
 United States Rubber Co.

**SCALES**

The Acromark Co.  
 The Black & Decker Mfg. Co.  
 Bonded Scale Co.  
 John Chatillon & Sons  
 The Exact Weight Scale Co.  
 The Howe Scale Co.

**SEATS**

Aero Trades Co.  
 Aircraft Products, Inc.  
 All American Aircraft Products, Inc.  
 Allied Aviation Corp.  
 Art Chrome Co. of America  
 Burlington Mills, Inc.  
 Capac Manufacturing Co.  
 Cluff Fabric Products  
 Firestone Aircraft Co.  
 Hayes Manufacturing Corp.  
 Kilgen Aircraft, Div. of Kilgen Organ Co.  
 King Plastics Corp.  
 Warren McArthur Corp.  
 Marine-Air Research Corp.  
 Perry Metal Products Co., Inc.  
 Taylorcraft Aviation Corp.  
 Technical Ply-Woods  
 Trans-American Airports Corp.  
 United States Plywood Corp.  
 United States Rubber Co.  
 Weber Showcase & Fixture Co., Inc.

**SHIELDING (RADIO & IGNITION)**

Aeronautical Radio Mfg. Co.  
 Air Associates, Inc.  
 Air-Shields, Inc.  
 Aircraft Instrument Service, Inc.  
 Aluminum Company of America  
 American Aluminum Ware Co.  
 American Phenolic Corp.  
 Bendix Aviation Corp.  
 Bolton Manufacturing Corp.  
 Chicago Metal Hose Corp.  
 General Aircraft Supply Corp.  
 Harvey Machine Co., Inc.  
 Kellogg Switchboard & Supply Co.  
 Menaugh-Dutterer Co.  
 Otto Aviation Corp.  
 Packard Electric Div., General Motors Corp.  
 Perry Metal Products Co. Inc.  
 Scintilla Magneto Div., Bendix Aviation Corp.  
 St. Louis Radio Engineering Co.  
 Titeflex, Inc.  
 Union Aircraft Products Corp.

**SHOP EQUIPMENT**

Airplane Manufacturing & Supply Corp.  
 Allis-Chalmers Mfg. Co.  
 R. B. Annis Co.  
 Anderson Bros. Mfg. Co.  
 The Armstrong Manufacturing Co.  
 The Aro Equipment Corp.  
 Berger Manufacturing Div., Republic Steel Corp.  
 The Black & Decker Mfg. Co.  
 The Buda Co.  
 The Carlyle Johnson Machine Co.  
 Geo. P. Clark Co.  
 Couse Laboratories  
 Detroit Sheet Metal Works  
 General Scientific Equipment Co.  
 The Imperial Brass Manufacturing Co.  
 Independent Pneumatic Tool Co.  
 I. Jacoel Cable Splicing Equipment Co.  
 Keystone Aircraft Products, Inc.  
 Lasalco Inc.  
 Logan Co.  
 Lyon-Raymond Corp.  
 Mall Tool Co.  
 Manbee Equipment Co.  
 Modern Engineering Co., Inc.

# ORDERS... without interference!

Orders coming through! Clearly. Distinctly. Thanks to the magic of modern aircraft radio reception, the vital lines of communication are maintained without interference . . . maintained between flight commander, plane crews, and ground bases.

• How has the chief source of such interference—high tension currents in ignition systems—been eliminated? The answer is simple. *By shielding the ignition cables with TITEFLEX RADIO SHIELDED IGNITION HARNESSES.*

• The Titeflex ignition harness has proved the efficiency and dependability of Titeflex metal tubing by actual per-

formance. Today it is standard equipment on the majority of Uncle Sam's war birds.

• But Titeflex will not be content with this leadership. Our research staff is constantly working to improve Titeflex products. Titeflex will be ready to meet the demand for flexible tubing of even wider application in the post-war planes of tomorrow. You are invited to consult our engineering staff on any problems you may now have or anticipate in post-war planning.



TITEFLEX, INC.

520 Frelinghuysen Ave., Newark 5, N. J.





**(Shop Equipment) Continued**

North American Electric Lamp Co.  
 Perry Metal Products Co. Inc.  
 Skilaw, Inc.  
 Standard Conveyor Co.  
 The Taft Peirce Mfg. Co.  
 The United States Electrical Tool Co.  
 Van Norman Co.

**SPARK PLUGS**

A C Spark Plug Div., General Motors Corp.  
 Actus Products Corp.  
 Aero Spark Plug Co., Inc.  
 Air Shields, Inc.  
 Aircraft Instrument Service, Inc.  
 Auburn Spark Plug Co. Inc.  
 Bendix Aviation Corp.  
 The B G Corp.  
 Champion Spark Plug Co.  
 The Denison Engineering Co.  
 The Electric Auto-Lite Co.  
 Firestone Aircraft Co.  
 General Aircraft Supply Corp.  
 Harvey Machine Co., Inc.  
 Scintilla Magneto Div., Bendix Aviation Corp.  
 Simmonds Aeroaccessories, Inc.  
 Trans-American Airports Corp.

**SPRINGS**

Advance Spring Corp.  
 Aircraft & Marine Specialty Co.  
 All Weather Springs  
 Barnes-Gibson-Raymond Div. of Associated Spring Corp.  
 Firestone Aircraft Co.  
 The Murray Corp. of America  
 Perry Metal Products Co. Inc.  
 Trans-American Airports Corp.  
 Tuthill Spring Co.

**STAMPINGS**

Ace Manufacturing Corp.  
 Acme Stamping & Mfg. Co.  
 The Acromark Co.  
 Advance Spring Corp.  
 Aero Supply Mfg. Co. Inc.  
 Aero Trades Co.  
 Aircraft & Marine Specialty Co.  
 Aircraft Containers Co.  
 Aircraft Specialties Co.  
 Airsealand Aircraft, Inc.  
 All Weather Springs

Alofs Manufacturing Co.  
 Aluminum Company of America  
 American Aluminum Ware Co.  
 American Central Manufacturing Corp.  
 American Magnesium Corp.  
 American Stamping & Mfg. Co.  
 Andrews & Perillo, Inc.  
 Arnolt Motor Co.  
 Associated Foundries & Manufacturers, Inc.  
 Automotive Rubber Co.  
 Edward F. Aymond Co.  
 Baltic Metal Products Co.  
 Barnes-Gibson-Raymond Div. of Associated Spring Corp.  
 Berger Brothers Co.  
 The Brewer-Titchener Corp.  
 Chas. W. Carll Sons  
 Chase Brass & Copper Co.  
 Cinch Manufacturing Corp.  
 Colgate Aircraft Corp.  
 Dahlstrom Metallic Door Co.  
 The Electric Auto-Lite Co.  
 The Folmer Graflex Corp.  
 Fox Co.  
 G & H Tool & Manufacturing Co.  
 The Hardware Specialties Mfg. Co.  
 Harvey Machine Co., Inc.  
 Hayes Manufacturing Corp.  
 Heyman Mfg. Co.  
 Highbridge-International Co.  
 Kenyon Instrument Co., Inc.  
 Keystone Aircraft Products, Inc.  
 Kulka Electric Mfg. Co., Inc.  
 Lansing Stamping Co.  
 H. K. Lorentzen, Inc.  
 The Murray Corp. of America  
 National Machine Products  
 Neu-Bart Stamping & Mfg. Co.  
 Numberall Stamp & Tube Co.  
 Operadio Manufacturing Co.  
 Perry Metal Products Co. Inc.  
 Pollak Manufacturing Co.  
 Reynolds Metals Co.  
 Roberts & Mander Stove Co.  
 Rohr Aircraft Corp.  
 Samson United Corp.  
 Spriesch Tool & Mfg. Co., Inc.  
 Edwin B. Stimpson Co., Inc.  
 Taylorcraft Aviation Corp.  
 Transue & Williams Steel Forging Corp.  
 Trippe Manufacturing Co.  
 Union Aircraft Products Corp.  
 United-Carr Fastener Corp.



*There is a*



# SPARK PLUG

*for every type of aviation engine*

**THE B & G CORPORATION**

*Contractors to the United States Army and Navy and Aircraft Engine Builders*  
136 WEST 52nd STREET, NEW YORK . . . Cable Address: Golsteco, New York

**(Stampings) Continued**

Veeder-Root Inc.  
Victor Metal Products Corp.  
Warner Manufacturing Co.  
E. W. Wiggins Airways, Inc.

**STARTERS**

Aircraft Instrument Service, Inc.  
American Bosch Corp.  
Delco-Remy Div., General Motors Corp.  
Detroit Stamping Co.  
Eclipse-Pioneer Div., Bendix Aviation Corp.  
Edo Aircraft Corp.  
L. M. Gear Co.  
General Aircraft Supply Corp.  
General Armature Corp.  
Jack & Heintz, Inc.  
Mechanical Products, Inc.  
Trans-American Airports Corp.

**SUBASSEMBLIES**

A & F Aluminum Products Co.  
Abrams Instrument Co.  
Adel Precision Products Corp.  
Aerco Corp.  
Aero Parts Manufacturing Co., Inc.  
Aero Supply Mfg. Co. Inc.  
Aero Trades Co.  
Aeronautical Mfg. Corp.  
Aeronautical Products, Inc.  
Aircraft Containers Co.  
Aircraft Products, Inc.  
Aircraft Specialties Co.  
Aircraft Welders, Inc.  
The Albano Co., Inc.  
All American Aircraft Products, Inc.  
American Aluminum Ware Co.  
American Central Manufacturing Corp.  
American Magnesium Corp.  
American Plywood Corp.  
American Stamping & Mfg. Co.  
The Apex Tool Co., Inc.  
Arnolt Motor Co.  
The Aro Equipment Corp.  
Associated Foundries & Manufacturers, Inc.  
Atlantic Diesel Corp.  
Auburn Spark Plug Co. Inc.  
Automatic Electrical Devices Co.  
Aviquipo Manufacturing Corp.  
Baker & Co., Inc.

Chicago Metal Hose Corp.  
Clifford Manufacturing Co.  
Colgate Aircraft Corp.  
Firestone Aircraft Co.  
G & H Tool & Manufacturing Co.  
General Bronze Corp.  
Goodyear Aircraft Corp.  
Harvey Machine Co., Inc.  
Hayes Manufacturing Corp.  
Keystone Aircraft Products, Inc.  
Kilgen Aircraft, Div. of Kilgen Organ Co.  
King Plastics Corp.  
Kulka Electric Mfg. Co., Inc.  
The Murray Corp. of America  
National Machine Products  
Neu-Bart Stamping & Mfg. Co.  
New Brunswick Die Molding Div. of Universal Plastics Corp.  
Operadio Manufacturing Co.  
Otto Aviation Corp.  
Perry Metal Products Co. Inc.  
Roberts & Mander Stove Co.  
Rohr Aircraft Corp.  
The Simmons Manufacturing Co.  
Southern California Airparts, Div. of Jarvis Manufacturing Co.  
Special Machine Tool Engineering Works  
Warner Manufacturing Co.  
Weber Showcase & Fixture Co., Inc.  
Westinghouse Electric & Manufacturing Co.  
E. W. Wiggins Airways, Inc.

**SUPERCHARGERS**

Aircraft Mechanics, Inc.  
Airesearch Manufacturing Co.  
Allis-Chalmers Mfg. Co.  
Clifford Manufacturing Co.  
Eclipse-Pioneer Div., Bendix Aviation Corp.  
Mobile Refrigeration Div., Bowser, Inc.  
Pacific Gear Plant, Western Gear Works  
Rohr Aircraft Corp.  
Sutorbilt Corp.

**Engine**

Airesearch Manufacturing Co.  
Clifford Manufacturing Co.  
Eclipse-Pioneer Div., Bendix Aviation Corp.



### **New Designs — New Products New Developments**

**O**UR war production missions at Firestone are our most important work. Chemists, physicists, metallurgists, and engineers all are devoting their production efforts to the development of new and better products for our fighting forces.

From Firestone laboratories have come such developments as the Channel Tread Tire, the Shatterproof High Altitude Oxygen Cylinder, the world's largest airplane tire and many other achievements.

A Firestone engineering representative is available on request—whether your problem is development, design or volume production of rubber, metal or plastic.

*Listen to the Voice of Firestone with Richard Crooks and the Firestone Symphony Orchestra, under the direction of Howard Barlow, Monday evenings, over N. B. C.*



# **Firestone**

## **AIRCRAFT COMPANY**

(Superchargers, Engine) *Continued*  
 General Electric Co.  
 L. M. Gear Co.  
 Jack & Heintz, Inc.  
 Pacific Gear Plant, Western Gear Works  
 Perry Metal Products Co. Inc.  
 Rohr Aircraft Corp.  
 Sutorbilt Corp.

### Cabin

Airesearch Manufacturing Co.  
 Clifford Manufacturing Co.  
 Eclipse-Pioneer Div., Bendix Aviation Corp.  
 General Electric Co.  
 Perry Metal Products Co. Inc.  
 Sutorbilt Corp.

### TAIL WHEEL ASSEMBLIES

Aerco Corp.  
 Aero Trades Co.  
 Air Associates, Inc.  
 Aircraft & Marine Specialty Co.  
 Bendix Aviation Corp., Pacific Div.  
 Colgate Aircraft Corp.  
 Firestone Aircraft Co.  
 General Aircraft Supply Corp.  
 The B. F. Goodrich Co.  
 Hayes Industries, Inc.  
 The Heath Co.  
 Menasco Manufacturing Co.  
 Perry Metal Products Co. Inc.  
 Scott Aviation Corp.  
 Trans-American Airports Corp.  
 Tyler Fixture Corp.  
 United States Rubber Co.

### TANKS

Aero Trades Co.  
 Aircraft & Marine Specialty Co.  
 Aircraft Components, Inc.  
 Aircraft Containers Co.  
 Aluminum Company of America  
 Aluminum Goods Mfg. Co.  
 American Magnesium Corp.  
 Associated Foundries & Manufacturers, Inc.  
 B. H. Aircraft Co.  
 Bellanca Aircraft Corp.  
 Chas. W. Carll Sons

Duramold Div. of Fairchild Engine & Airplane Corp.  
 Firestone Aircraft Co.  
 The B. F. Goodrich Co.  
 Harvey Machine Co., Inc.  
 Hewitt Rubber Corp.  
 Independent Iron Works, Ltd.  
 King Plastics Corp.  
 Lasalco Inc.  
 The Marquette Metal Products Co.  
 Perry Metal Products Co. Inc.  
 Pollak Manufacturing Co.  
 Samson United Corp.  
 Southern California Airparts, Div. of Jarvis Manufacturing Co.  
 Taylorcraft Aviation Corp.  
 Trans-American Airports Corp.  
 Tyler Fixture Corp.  
 United States Rubber Co.  
 Weber Showcase & Fixture Co., Inc.

### TESTING & INSPECTION EQUIPMENT

Airplane Manufacturing & Supply Corp.  
 Allen Electric & Equipment Co.  
 American Machine & Metals, Inc.  
 American Stamping & Mfg. Co.  
 Anderson Bros. Mfg. Co.  
 The B G Corp.  
 The W. W. Boes Co.  
 The Brush Development Co.  
 John Chatillon & Sons  
 Clifford Manufacturing Co.  
 The Denison Engineering Co.  
 W. C. Dillon & Co., Inc.  
 General Electric X-Ray Corp.  
 General Radio Co.  
 Industrial Sound Control  
 Jack & Heintz, Inc.  
 I. Jacoel Cable Splicing Equipment Co.  
 The Kelley-Koett Mfg. Co.  
 Kenyon Instrument Co., Inc.  
 Lane Wells Co.  
 Leeds & Northrup Co.  
 Liberty Motors & Engineering Corp.  
 Link-Belt Co.  
 Manbee Equipment Co.  
 Mobile Refrigeration Div., Browser, Inc.  
 Models, Inc.  
 Perry Metal Products Co. Inc.  
 Pollak Manufacturing Co.

**PRECISION PARTS  
and ASSEMBLIES**

... that are helping  
American planes achieve  
victory all over the world.

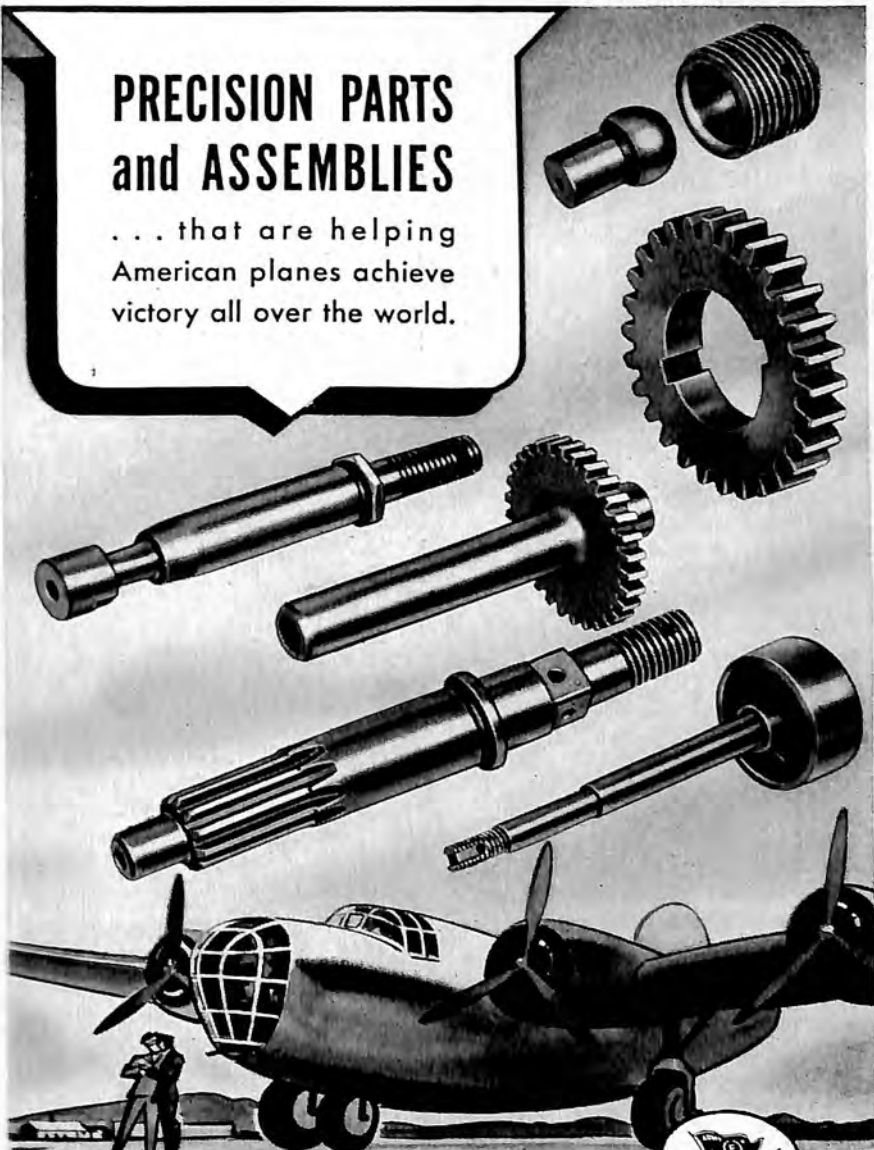

*The* **Marquette** METAL PRODUCTS CO.  
CLEVELAND 10, OHIO

*Manufacturers of:* HYDRAULIC AND ELECTRIC WINDSHIELD WIPERS FOR AIRCRAFT  
HYDRAULIC GOVERNORS FOR DIESEL ENGINES • ROLLER BEARING TEXTILE SPINDLES • FUEL OIL PUMPS  
AIR COMPRESSORS • PRECISION PARTS AND ASSEMBLIES



**(Testing & Inspection Equipment)***Continued*

Rocky Mountain Steel Products, Inc.  
 Rohr Aircraft Corp.  
 St. Louis Radio Engineering Co.  
 J. Earl Smith  
 Smith Tool-Engineering Co.  
 Special Machine Tool Engineering Works  
 C. J. Tagliabue Mfg. Co.  
 Taylor Manufacturing Co.  
 Tenney Engineering, Inc.  
 The Triplett Electrical Instrument Co.

**T I R E S & T U B E S**

Bacon Vulcanizer Mfg. Co.  
 Firestone Aircraft Co.  
 General Aircraft Supply Corp.  
 The B. F. Goodrich Co.  
 Trans-American Airports Corp.  
 United States Rubber Co.

**T O O L S**

Acme Pattern & Tool Co., Inc.  
 The Acromark Co.  
 Adjustable Clamp Co.  
 Aero Tool Co.  
 Aeronautical Mfg. Corp.  
 Airco Tool Co.  
 Aircraft Production Engineers  
 Aircraft Screw Products Co., Inc.  
 Aircraft Tools, Inc.  
 Airsealand Aircraft, Inc.  
 American Stamping & Mfg. Co.  
 Andrews & Perillo, Inc.  
 The Apex Tool Co., Inc.  
 Armstrong Bros. Tool Co.  
 The Armstrong Manufacturing Co.  
 The Aro Equipment Corp.  
 Astra Engineering Co.  
 E. C. Atkins & Co.  
 Automatic Electrical Devices Co.  
 The Automatic Vise Sales Co.  
 Baker-Spiegel Co.  
 Bendix Aviation Corp., Philadelphia Div.  
 The Black & Decker Mfg. Co.  
 Campbell Hdwe. & Supply Co.  
 Chicago Pneumatic Tool Co.  
 The Cincinnati Lathe & Tool Co.  
 The Cincinnati Shaper Co.  
 The Cleveland Pneumatic Tool Co.  
 The Columbian Vise & Mfg. Co.  
 Criterion Machine Works

General Aircraft Supply Corp.  
 The Geometric Tool Co.  
 Graham Rotary File & Tool Co.  
 Guiberson Diesel Engine Co.  
 The Hall Mfg. Co.  
 Haynes Stellite Co.  
 Hy-Pro Tool Co.  
 The Imperial Brass Manufacturing Co.  
 Independent Pneumatic Tool Co.  
 I. Jacoel Cable Splicing Equipment Co.  
 Kennanmetal Inc.  
 Keystone Aircraft Products, Inc.  
 Liberty Motors & Engineering Corp.  
 The Lufkin Rule Co.  
 McGrath St. Paul Co.  
 Manbee Equipment Co.  
 Metal & Tool Reconditioning Service  
 Metal Carbides Corp.  
 Millers Falls Co.  
 Morse Tool Co.  
 Pannier Bros. Stamp Co.  
 The Parker Appliance Co.  
 The Paulson Tools Inc.  
 Perry Metal Products Co. Inc.  
 Pioneer Engineering & Manufacturing Co.  
 H. K. Porter, Inc.  
 Pratt & Whitney, Div. Niles-Bement Pond Co.  
 Proconier Safety Chuck Co.  
 The Sheffield Corp.  
 Skilaw, Inc.  
 Snap-on Tools Corp.  
 Special Machine Tool Engineering Works  
 Standard Machinery Co.  
 Stanley Electric Tool Div.  
 The Taft Peirce Mfg. Co.  
 Taylorcraft Aviation Corp.  
 George A. Terry Co.  
 The Henry G. Thompson & Son Co.  
 The United States Electrical Tool Co.  
 Utica Drop Forge & Tool Corp.  
 Vard Inc.  
 Vascoloy-Ramet Corp.  
 Wales-Strippit Corp.  
 N. A. Woodworth Co.

**T U B I N G**

Aircraft Products, Inc.  
 Aircraft Specialties Co.  
 Aluminum Company of America  
 American Magnesium Corp.

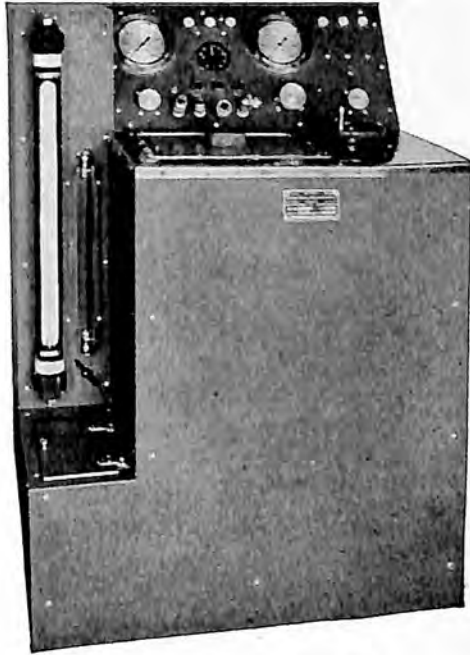

*Special Skills and Equipment for*  
**High-Precision Machine Work**  
**Electrical Assembly Work**

As a manufacturer, Liberty makes highly accurate testing equipment and service tools for aircraft, of which the Propeller Governor Test Unit at the left is just one example. These Liberty products are used by armed forces and governments of the United Nations, as well as by

airlines and aircraft plants. In addition, as a sub-contractor, Liberty produces quantities of high-precision machined parts and electrical assemblies for other manufacturers. Maybe Liberty's special skills and equipment can help you. We'll gladly tell you more about them.

**LIBERTY MOTORS**  
**& ENGINEERING CORPORATION**  
 BALTIMORE-1, MARYLAND

MANUFACTURERS OF AIRCRAFT SERVICE TOOLS AND TEST EQUIPMENT

**(Tubing) Continued**

American Tube Bending Co., Inc.  
 Arnolt Motor Co.  
 Atlantic India Rubber Works, Inc.  
 Edward F. Aymond Co.  
 Baker Steel & Tube Co.  
 The Bowling Green Rubber Co.  
 Breeze Corporations, Inc.  
 Bundy Tubing Co.  
 The Carpenter Steel Co.  
 Chase Brass & Copper Co.  
 Chicago Metal Hose Corp.  
 Clifford Manufacturing Co.  
 Columbia Steel Co.  
 Federal Metal Hose Corp.  
 The Formica Insulation Co.  
 General Aircraft Supply Corp.  
 Globe Steel Tubes Co.  
 The B. F. Goodrich Co.  
 Hope Webbing Co.  
 Irvington Varnish & Insulator Co.  
 Johns-Manville Sales Corp.  
 National Tube Co.  
 The Ohio Seamless Tube Co.  
 Otto Aviation Corp.  
 Perry Metal Products Co. Inc.  
 Pierce Plastics, Inc.  
 Pittsburgh Steel Co.  
 Precision Tube Co.  
 Republic Steel Corp.  
 Resistoflex Corp.  
 Revere Copper and Brass Inc.  
 Reynolds Metals Co.  
 Seamlex Co., Inc.  
 Spaulding Fibre Co., Inc.  
 Steel & Tube Div., Republic Steel Corp.  
 Summerill Tubing Co.  
 Superior Tube Co.  
 Titeflex, Inc.  
 Trans-American Airports Corp.  
 Tubular Service Corp.  
 United States Rubber Co.

**TURRETS & PARTS**

Aero Supply Mfg. Co. Inc.  
 Allied Aviation Corp.  
 Bellanca Aircraft Corp.  
 Bendix Products Div. of Bendix Aviation Corp.  
 Firestone Aircraft Co.  
 General Electric Co.  
 Marine-Air Research Corp.  
 The Murray Corp. of America  
 Perry Metal Products Co. Inc.

Plastic Manufacturers, Inc.  
 Samson United Corp.  
 Sperry Gyroscope Co., Inc.

**UNIFORMS**

S. Appel and Company, Inc.

**VALVES**

Electrol Inc.  
 Moore-Eastwood & Co.  
 A. Schrader's Son, Div. of Scovill Manufacturing Co.

**VALVES (CONTROL)**

Adel Precision Products Corp.  
 Aero Supply Mfg. Co. Inc.  
 Aeronautical Mfg. Corp.  
 Aircraft Products Co.  
 Alco Valve Co.  
 American Screw Products  
 Associated Foundries & Manufacturers, Inc.  
 Barber-Colman Co.  
 Bendix Aviation Corp., Pacific Div.  
 Bendix Aviation Corp., Philadelphia Div.  
 Chase Brass & Copper Co.  
 Clifford Manufacturing Co.  
 Ralph C. Coxhead Corp.  
 The Denison Engineering Co.  
 The Dole Valve Co.  
 The Fulton Sylphon Co.  
 General Controls Co.  
 Hoof Products Co.  
 The Imperial Brass Manufacturing Co.  
 Kenyon Instrument Co., Inc.  
 The Oilgear Co.  
 Otto Aviation Corp.  
 The Parker Appliance Co.  
 Perry Metal Products Co. Inc.  
 Pesco Products Co.  
 Rohlm Manufacturing Co., Inc.  
 C. J. Tagliabue Mfg. Co.  
 Trans-American Airports Corp.  
 United Aircraft Products, Inc.  
 The Weatherhead Co.

**VENEERS**

Allied Aviation Corp.  
 American Plywood Corp.  
 National Veneer & Lumber Co.



## How Much Is a Valve Worth ... to YOU?

HERE'S A TIRE SAVER

SEALING WASHER

This Schrader cap, costing a few cents, protects a \$20 to \$50 tire and tube assembly. It and its millions of brothers are protecting billions of pounds of rubber. Use them, don't lose them!



# Schrader

CONTROLS THE AIR



The valve on this life vest is a little thing, yet *life* itself is entrusted to it. This signifies the dependability of Schrader Valves.

The same dependability built into Schrader life vest valves, also goes into the development of a complete line of Schrader industrial compressed air controls and pneumatic valves that you can depend on in *your* application.

Whatever phase of the aircraft business you are engaged in, look into the facts about Schrader Valves and Air Controls. Write for information on Schrader Controls or Valves to meet *your* needs today.

**SCHRADER AIRCRAFT & AUTOMOTIVE PRODUCTS**

Oxygen Check Valves • Shock Strut Valves • Gauging Devices • Replaceable Tire Valves • Cores • Caps and Gauges

**(Veneers) Continued**

J. V. G. Posey & Co.  
 Technical Ply-Woods  
 Trans-American Airports Corp.  
 United States Plywood Corp.

**VENTILATING & AIR  
 CONDITIONING  
 EQUIPMENT**

Airesearch Manufacturing Co.  
 American Foundry & Furnace Co.  
 American Foundry Equipment Co.  
 American Machine & Metals, Inc.  
 Anemostat Corp. of America  
 Automatic Electrical Devices Co.  
 Barber-Colman Co.  
 Chas. W. Carll Sons  
 Champion Blower & Forge Co.  
 Chicago Metal Hose Corp.  
 Clifford Manufacturing Co.  
 Detroit Sheet Metal Works  
 Diehl Manufacturing Co.  
 Drayer and Hanson, Inc.  
 Friez Instrument, Div. of Bendix  
   Aviation Corp.  
 The Fulton Sylphon Co.  
 General Controls Co.  
 Harvey Machine Co., Inc.  
 Ilg Electric Ventilating Co.  
 McQuay Inc.  
 Paasche Airbrush Co.  
 Pangborn Corp.  
 Perry Metal Products Co. Inc.  
 Samson United Corp.  
 Sensenich Brothers  
 Snapvent Co.  
 Surface Combustion Corp.  
 Sutorbilt Corp.  
 The Trane Co.  
 Trans-American Airports Corp.  
 Waukesha Motor Co.  
 Westinghouse Electric & Manufactur-  
   ing Co.

**VIBRATION DAMPERS**

Arrowhead Rubber Co.  
 Associated Rubber Products Co.  
 Atlantic India Rubber Works, Inc.  
 Bushings, Inc.  
 Chicago Metal Hose Corp.  
 Connecticut Hard Rubber Co.  
 Firestone Aircraft Co.  
 The B. F. Goodrich Co.  
 Harris Products Co.

Lord Manufacturing Co.  
 The M B Manufacturing Co., Inc.  
 Packless Metal Products Corp.  
 Perry Metal Products Co. Inc.  
 Samson United Corp.  
 Seamlex Co., Inc.  
 The Sheffield Corp.  
 United States Rubber Co.

**WELDING  
 EQUIPMENT**

Allis-Chalmers Mfg. Co.  
 Ampco Metal, Inc.  
 Chase Brass & Copper Co.  
 Colgate Aircraft Corp.  
 Continental Machines, Inc.  
 Couse Laboratories  
 C. R. Daniels, Inc.  
 Dockson Corp.  
 Federal Aircraft Works  
 General Aircraft Supply Corp.  
 General Electric Co.  
 General Scientific Equipment Co.  
 Haynes Stellite Co.  
 Hobart Brothers Co.  
 Lyon-Raymond Corp.  
 The Alexander Milburn Co.  
 Modern Engineering Co., Inc.  
 Pier Equipment Mfg. Co.  
 Smith Welding Equipment Corp.  
 Solar Aircraft Co.  
 The Taylor-Winfield Corp.  
 Thomson-Gibb Electric Welding Co.  
 Victor Equipment Co.  
 Westinghouse Electric & Manufactur-  
   ing Co.

**WHEELS**

Air Associates, Inc.  
 Bendix Products Div. of Bendix  
   Aviation Corp.  
 Firestone Aircraft Co.  
 General Aircraft Supply Corp.  
 Goodyear Aircraft Corp.  
 Hayes Industries, Inc.  
 Norton Co.  
 Pacific Aviation, Inc.  
 Scott Aviation Corp.  
 Trans-American Airports Corp.  
 United States Rubber Co.

**WINDSHIELD  
 WIPERS**

Alco Valve Co.  
 E. A. Laboratories, Inc.

*Efficient Vibration Control*  
**IN AIRCRAFT**

<p><b>TUBE FORM MOUNTINGS FOR</b></p> <p>SEATS COWLS RADIO TABLES RADIATOR ENGINES IN-LINE ENGINES NAVIGATOR'S TABLES CONTROL ROD JOINTS TAIL WHEEL ASSEMBLIES</p>	<p><b>LANDING WHEEL ASSEMBLIES</b></p> <p>OIL TANKS RADIATORS ELEVATOR CONTROL RODS MOTOR BRUSH MOUNTINGS CABIN INTERCOOLERS CABIN SUPERCHARGERS</p>	<p><b>PLATE FORM MOUNTINGS FOR</b></p> <p>AUTOMATIC PILOTS PROPELLER SPINNERS INSTRUMENT PANELS CARTRIDGE STARTERS BOMB SIGHTS COMPASSES MICROPHONES CARBURETORS RADIOS CAMERAS</p>	<p><b>ANTENNAS</b> RADIATORS OIL TANKS BATTERY BOXES AUTOSTAY DEVICES AUXILIARY POWER EQUIPMENT FLIGHT ANALYZERS EXHAUST GAS ANALYZERS VOLTAGE CONTROL BOXES</p>
--	--	---	--

DYNAFOCAL SUSPENSION FOR ALL RADIAL AIRCRAFT ENGINES

~~~~~

**LORD**  
BONDED RUBBER

*Shear Type*  
**MOUNTINGS**

**L**ORD produces, in standard sizes, an infinite variety of bonded rubber shear type mountings for vibration control, ranging from mountings for radial engines to those used for very delicate, light-weight instruments. In addition, Lord produces thousands of special parts designed for particular conditions. While designed functionally to isolate vibration, Lord products have the additional characteristics of being compact, light in weight, and easy to install.

If you have a vibration problem call in a Lord Vibration Engineer or write for Bulletins 103 and 104 which contain engineering information on vibration control and illustrations of all types of Lord Mountings.

**LORD MANUFACTURING COMPANY, ERIE, PA.**  
*Specialists in Bonded Rubber Products*

**AIRCRAFT USERS OF LORD MOUNTINGS**

BEECH - BELL - BELLANCA - BOEING  
BREWSTER - CESSNA - CONSOLIDATED  
CURTISS-WRIGHT - DOUGLAS - EASTERN  
AIRCRAFT - FAIRCHILD - FLEETWING  
GLEN L. MARTIN - GLOBE - GRUMMAN  
HARLOW - HIGGINS - HOWARD - HUGHES  
INTERSTATE - KELLETT - LOCKHEED  
LUSCOMBE - MCDONNELL - NORTH  
AMERICAN - NORTHROP - PIPER  
REPUBLIC - RYAN - TIMM - VEGA  
VOUGHT-SIKORSKY - VULTEE - WACO

***Back the Attack with War Bonds***

**IT TAKES RUBBER IN SHEAR TO ABSORB VIBRATION**



**(Windshield Wipers) Continued**

L. M. Gear Co.  
The Marquette Metal Products Co.  
Trans-American Airports Corp.  
United States Rubber Co.

**WIRE & CABLE  
(ELECTRICAL)**

The Accurate Insulated Wire Corp.  
Aeronautical Radio Mfg. Co.  
Aluminum Company of America  
American Steel & Wire Co.  
Boston Insulated Wire & Cable Co.  
Chase Brass & Copper Co.  
Columbia Steel Co.  
The Crescent Co., Inc.  
Crescent Insulated Wire & Cable Co.  
The Electric Auto-Lite Co.  
Federal Telephone & Radio Corp.  
General Aircraft Supply Corp.  
Kellogg Switchboard & Supply Co.  
Keyon Instrument Co., Inc.  
The Oakonite Co.  
Operadio Manufacturing Co.  
Otto Aviation Corp.  
Packard Electric Div., General Motors Corp.  
Precision Tube Co.  
John A. Roebling's Sons Co.  
Simplex Wire & Cable Co.  
J. Earl Smith  
Trans-American Airports Corp.  
United States Rubber Co.

**WIRE & CABLE  
(MECHANICAL &  
FLEXIBLE SHAFTS)**

Aeronautical Radio Mfg. Co.  
Aircraft Instrument Service, Inc.  
Aluminum Company of America  
American Chain & Cable Co., Inc.  
American Steel & Wire Co.  
Arens Controls, Inc.  
Bendix Aviation Corp., Pacific Div.  
Bethlehem Steel Co.  
General Aircraft Supply Corp.  
Mall Tool Co.  
Otto Aviation Corp.  
John A. Roebling's Sons Co.  
Trans-American Airports Corp.  
United States Rubber Co.  
The S. S. White Dental Mfg. Co.

**MISCELLANEOUS**

A T C Co., Inc.

Acme Steel Co.  
The Acromark Co.  
Adhere, Inc.  
Aero Supply Mfg. Co. Inc.  
Aero Trades Co.  
Aerojet Engineering Corp.  
Aeronautical Mfg. Corp.  
Aircraft & Marine Specialty Co.  
Aircraft Lumber Co.  
Aircraft Products, Inc.  
Aircraft Screw Products Co., Inc.  
Allied Aviation Corp.  
Alpha Metals, Inc.  
Aluminum Ladder Co.  
American Armament Corp.  
American Photocopy Equipment Co.  
American Roof Truss Co.  
American Screw Co.  
American Stamping & Mfg. Co.  
Angier Sales Corp.  
The Areo Co.  
Atlantic India Rubber Works, Inc.  
Auburn Spark Plug Co. Inc.  
Automatic Electrical Devices Co.  
Babbitt Industrial Specialties Co.  
Barrett Equipment Co.  
The Bell Co., Inc.  
Bellanca Aircraft Corp.  
Black Bear Co., Inc.  
Bokelman Co., Inc.  
Buckeye Iron & Brass Works  
Burlington Mills, Inc.  
Eugene Cantin Co., Inc.  
The Centerless Grinding Co., Inc.  
Chicago Metal Hose Corp.  
Clifford Manufacturing Co.  
Cook Electric Co.  
Dahlstrom Metallic Door Co.  
C. R. Daniels, Inc.  
Duramold Div. of Fairchild Engine & Airplane Corp.  
The Folmer Graflex Corp.  
The Fostoria Pressed Steel Corp.  
The Fulton Sylphon Co.  
General Aircraft Supply Corp.  
The Hardware Specialties Mfg. Co.  
Harvey Machine Co., Inc.  
Haskelite Manufacturing Corp.  
Haynes Stellite Co.  
The Howe Scale Co.  
Hyland Machine Co.  
Ideal Commutator Dresser Co.  
The Imperial Brass Manufacturing Co.  
Intercontinental Engineers, Inc.  
J. V. W. & Co.

PROVING GROUND

FOR  
*Tomorrow*

FROM the war will come a better world... with technical developments years before their time. An aircraft windshield wiper which was one of our fledglings just a few years back, has become an accepted safety device—now flying with the major U. S. Airlines, with the Army and the Navy.

Units of new design will be applicable in many fields, available for the private airplane as well as the transport. We have made practical use of the Proving Ground for Tomorrow.

*The* Marquette

METAL PRODUCTS COMPANY  
Cleveland 10, Ohio



*Manufacturers of:* HYDRAULIC AND ELECTRIC WINDSHIELD WIPERS FOR AIRCRAFT  
HYDRAULIC GOVERNORS FOR DIESEL ENGINES • ROLLER BEARING TEXTILE SPINDLES • FUEL OIL PUMPS  
AIR COMPRESSORS • PRECISION PARTS AND ASSEMBLIES

*(Miscellaneous) Continued*

Johns-Manville Sales Corp.  
 Keystone Carbon Co., Inc.  
 Kilgen Aircraft, Div. of Kilgen Organ  
 Co.  
 King Plastics Corp.  
 Lincoln-Schlueter Floor Machinery  
 Co.  
 David Linzer & Sons, Inc.  
 H. K. Lorentzen, Inc.  
 Major Aircraft Foundry  
 Marine-Air Research Corp.  
 National Machine Products  
 Newark Wire Cloth Co.  
 Ohlsson & Rice Manufacturing Co.  
 Oil-Rite Corp.  
 Otto Aviation Corp.  
 Owens-Corning Fiberglas Corp.  
 Pacific Engineering Corp.  
 The C. F. Pease Co.  
 Pollak Manufacturing Co.

Puritan Compressed Gas Corp.  
 Radiator Specialty Co.  
 Rocky Mountain Steel Products, Inc.  
 Rohr Aircraft Corp.  
 St. John X-Ray Service, Inc.  
 St. Louis Radio Engineering Co.  
 Samson United Corp.  
 Special Machine Tool Engineering  
 Works  
 Technical Ply-Woods  
 Tel-Autograph Corp.  
 Thompson Products, Inc.  
 Trans-American Airports Corp.  
 United Aircraft Products, Inc.  
 Uniform Hood Lace Co.  
 Veeder-Root Inc.  
 Warner Manufacturing Co.  
 Wassell Organization  
 Wayne Chemical Products Co.  
 E. W. Wiggins Airways, Inc.

## AIRCRAFT ASSEMBLIES

EXPERTS IN  
 PLYWOOD WORK  
 FOR 25 YEARS



**Kilgen**  
**Aircraft**

4443 COOK AVE.  
 ST. LOUIS, MO.

### AVAILABLE FACILITIES

for

the Manufacture of

AIRCRAFT ASSEMBLIES



Modern Tool Room—Latest Equip-  
 ment for Magnafluxing, Sandblast-  
 ing, Spray Painting—AAF-Certified  
 Welders—Closely Controlled In-  
 spection.



We Invite Your Inquiries

E. W. WIGGINS AIRWAYS, INC.

Est. 1928

Manufacturers of Welded Assem-  
 blies, Stressed Skin Assemblies,  
 Fabric Covered Parts

NORWOOD, MASSACHUSETTS



*Precision Craftsmanship  
in Aircraft Accessories*

RESEARCH      MANUFACTURE  
DEVELOPMENT

|                                |                     |
|--------------------------------|---------------------|
| Oil Temperature Regulators     | Pumps               |
| Hydraulic Operating Valves     | Fuel Cocks          |
| Oil Dilution Controllers       | Fuel Pumps          |
| Oil Dilution Valves            | Fuel Strainers      |
| Thermostatic Valves            | Control Assemblies  |
| Glycol Radiators               | Pressure Regulators |
| Y Drain Valves                 | Actuating Cylinders |
| Accumulators                   | Landing Gear Struts |
| Nose and Tail Wheel Assemblies |                     |

**UNITED AIRCRAFT PRODUCTS, Inc.**  
Main Office: **DAYTON, OHIO**

*Plants: Dayton, Ohio . . . Los Angeles, Calif.  
Belleville, New Jersey*

# ALPHABETICAL DIRECTORY OF EQUIPMENT MANUFACTURERS AND SUPPLIERS OF BASIC MATERIALS AND FABRICATIONS

---

## A

---

- AC SPARK PLUG DIV., GENERAL MOTORS CORP.,** Flint 2, Mich.  
PERSONNEL: G. Mann, Jr., Gen. Mgr.; L. W. Tobin, Prod. Mgr.; W. S. Isherwood, Sales Mgr.; H. R. Wells, Pur. Dir.; W. E. Milner, Pers. Dir.; M. W. Gotthelf, Pub. Dir.; E. McGinnis, Adv. Mgr.; C. W. McKinley, Chief Engr.
- A & F ALUMINUM PRODUCTS CO.,** 3421 E. 22nd St., Los Angeles, Calif.  
PERSONNEL: R. M. Allan, Pres., Treas. & Gen. Mgr.; C. R. Fleishman, V. Pres. & Secy.; B. R. Sweany, Pur. Agt.
- A T C CO., INC.,** 34 E. Logan St., Philadelphia, Pa.  
PERSONNEL: G. H. Johanson, Pres.; J. D. Andrews, V. Pres. & Sales Mgr.; H. E. Kenyon, Secy. & Pur. Agt.; H. Huber, Gen. Mgr.; W. W. Winters, Pub. Dir.; I. G. Johanson, Chief Engr.
- ABRAMS INSTRUMENT CO.,** 606 E. Shiawassee St., Lansing, Mich.  
PERSONNEL: T. Abrams, Owner, W. S. Karr, Gen. Mgr.
- ABRASIVE MACHINE TOOL CO.,** Dexter Rd., E. Providence, R. I.  
PERSONNEL: N. D. MacLeod, Pres. & Gen. Mgr.; E. S. Brackett, Jr., V. Pres.; M. E. Young, Secy.; C. G. MacLeod, Treas.; W. Sceeles, Sales Mgr.; H. Hulme, Pur. Agt.; H. A. Patenaude, Pers. Dir.; L. E. Marsh, Chief Engr.
- THE ACCURATE INSULATED WIRE CORP.,** 85 Willow St., New Haven, Conn.  
PERSONNEL: J. T. Whalen, Pres.; J. T. Whalen, Jr., V. Pres.; I. Whalen, Secy. & Treas.; L. W. Feldman, Gen. Mgr.
- ACE MANUFACTURING CORP.,** 1205 E. Erie Ave., Philadelphia 24, Pa.  
PERSONNEL: G. M. Jones, Pres., Treas., & Gen. Mgr.; F. G. Schutz, V. Pres.; A. W. Engel, Secy. & Pur. Dir.; H. G. Zieher, Prod. Mgr.; H. V. Coulston, Chief Engr.
- ACME ELECTRIC HEATING CO.,** 1217 Washington St., Boston, Mass.  
PERSONNEL: H. E. Price, Pres., Treas. & Sales Mgr.; G. A. Rice, V. Pres.
- ACME PATTERN & TOOL CO., INC.,** Dayton 3, O.  
PERSONNEL: K. A. Stein, Pres. & Gen. Mgr.; G. H. Stein, V. Pres. & Asst. Gen. Mgr.; J. A. Heitzmann, V. Pres.-Finance; W. C. Lewis, Secy. & Treas.; R. J. Stein, Asst. Secy. & Treas.; A. F. Leis, Chief Engr.; R. Coblenze, Prod. Supt.; H. G. Hodges, Ind. Rel.; C. J. Lachey, Gen. Mgr., Pattern Div.; C. Laughter, Gen. Mgr., Tool Div.; A. J. Fischer, A. J. Tate, Co-Supts., Foundry Div.; S. E. Yendes, Pers. Dir.; A. F. Maish, Pur. Agt.
- ACME STAMPING & MFG. CO.,** 205 Corliss St., Pittsburgh, Pa.  
PERSONNEL: C. A. Kays, Pres. & Gen. Mgr.; T. H. Hunter, V. Pres.; H. J. Wilhelm, Secy., Treas. & Pur. Agt.
- ACME STEEL CO.,** 2840 Archer Ave., Chicago, Ill.  
PERSONNEL: C. S. Traer, Pres.; C. J. Sharp, V. Pres.; C. M. MacChesney, V. Pres. & Secy.; T. A. Rand, Treas.; W. S. Huss, Sales Mgr.; H. L. Brueggemann, Pur. Agt.; H. L. Bills, Pers. Dir.; V. C. Hogren, Pub. Dir.; R. E. Orton, S. Rasul, Chief Engrs.
- ACME WHITE LEAD & COLOR WORKS,** 8250 St. Aubin Ave., Detroit, Mich.  
PERSONNEL: A. W. Stuedel, Pres.; C. A. Campbell, V. Pres. & Gen. Mgr.; F. L. Knapp, Secy.; R. S. Stephens, Treas.; A. J. Reiss, Sales Mgr.; W. T. Glidden, Pur. Agt.; J. E. Mitchel, Pers. Dir.; F. J. Schulte, Pub. Dir.; C. Kelley, Chief Engr.
- ACORN BEARING CO.,** 68 Stanley St., New Britain, Conn.  
PERSONNEL: J. Neubauer, Pres.; M. Neubauer, V. Pres.
- ACRO ELECTRIC CO.,** 3167 Fulton Rd., Cleveland, O.  
PERSONNEL: B. Winston, Pres.; H. H. Marshman, V. Pres.; C. A. Robinson, Gen. Mgr.; J. S. McCombe, Sales Mgr.; L. A. Wald, Pur. Agt.; E. F. Kohl, Chief Engr.
- THE ACROMARK CO.,** 9-13 Morrell St., Elizabeth 4, N. J.  
PERSONNEL: H. O. Bates, Owner, Gen. Mgr. & Pub. Dir.; S. R. Rosenberg, Secy., Compt., Pur. Dir. & Pers. Dir.; W. A. Heine, Sr., Prod. Mgr.; A. W. Murdoch, Sales Mgr.; G. H. Martin, Adv. Mgr.; W. A. Heine, Jr., Chief Engr.
- ACTUS PRODUCTS CORP.,** 10-14 N. Bleeker St., Mt. Vernon, N. Y.  
PERSONNEL: C. W. Prochaska, Pres., Gen. Mgr. & Sales Mgr.; H. McCahan, V. Pres. & Pur. Agt.; J. M. Regan, Secy.; H. McCarthy, Treas.

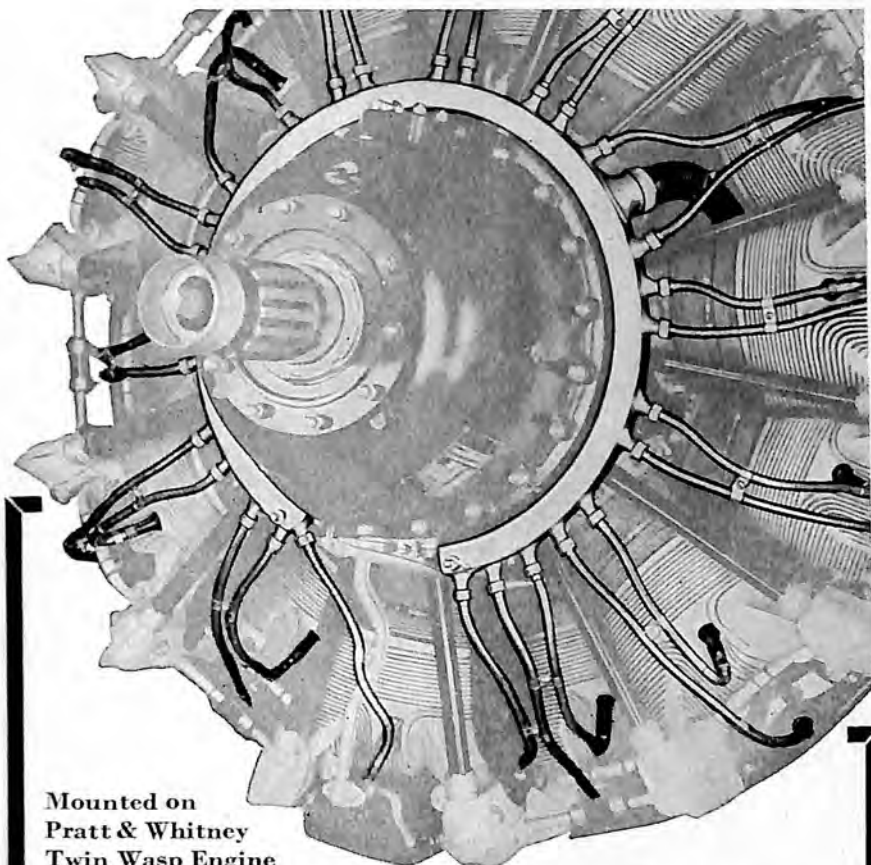

Mounted on  
Pratt & Whitney  
Twin Wasp Engine

## Built for the Engines of Combat

BOLTON Assemblies are used on war plane, tank and boat engines to drain off spark interference.

*Electrically*, they are designed to accomplish this with maximum effectiveness. *Physically*, they have the good fit and extreme ruggedness to insure dependable service under the severe grind of modern combat!

**BOLTON  
SHIELDED  
IGNITION  
ASSEMBLIES**

BOLTON MANUFACTURING  
CORPORATION  
WEST HAVEN, CONN.



MAKING HISTORY...  and SAFE LANDINGS



**PIONEER PARACHUTE COMPANY, INC.**  
 MANCHESTER, CONNECTICUT, U. S. A.

CABLE ADDRESS PPAR TEL Manchester, 4157

## LEACH RELAYS

In the early days of commercial aviation, the Leach Relay Company pioneered in the design and production of *relays* suitable for aircraft applications, and *Leach relays* have since been universally used by all the leading airlines.

Today we are working 100% on War Production supplying *relays* suitable for military aircraft and for all branches of the service. In this field we again pioneered, designing and producing many *relays* for these applications. We are constantly developing new and special items.

You are invited to consult with us on your *relay* problems.

**LEACH RELAY CO., INC.**  
**5915 Avalon Blvd., Los Angeles, Calif.**

*Relays Exclusively*



For  
VICTORY  
buy  
WAR BONDS  
and STAMPS

*Acme for Action*



WHEN our daring paratroopers leap upon the enemy from the air, action is sudden, fast, decisive.

Fast action, decisive action is just as vital on the home front. Here at Acme, we keep stepping on the gas for all-out production in the shortest possible time. Whether it's patterns, dies, heat-treated aluminum castings, or specialized tools needed by war plants, our watchword remains, "Do It Right—And Do It Fast."

We have an experienced engineering staff that will be glad to talk over your problems, with no obligation to you.

**ACME PATTERN & TOOL COMPANY, INC.**

**DAYTON, OHIO**

Heat-Treated Aluminum Castings—Patterns—Tools—Tool Designing—  
Production Processing

**THE ADAMS CO.,** Dubuque, Ia.,  
PERSONNEL: E. Adams, Pres.; H. Adams, Secy. & Treas.

**THE ADAMS & WESTLAKE CO.,**  
Elkhart, Ind.

PERSONNEL: W. A. Smith, Pres.; W. T. Brassil, V. Pres. & Gen. Mgr.; R. W. Hansen, Secy. & Treas.; S. C. Stafford, Sales Mgr.; W. A. Williams, Pur. Dir.

**ADEL PRECISION PRODUCTS CORP.,**

10777 Van Owen St., Burbank, Calif.  
PERSONNEL: H. R. Ellinwood, Pres. & Adv. Mgr.; R. D. Cavanaugh, V. Pres.; S. D. Amdisen, Treas.; M. L. Jones, Prod. Mgr.; J. S. Garraway, Sales Mgr., Hydraulics Div.; R. L. Freeman, Pur. Dir.; F. O. Field, Pers. Dir.; J. W. Kelly, Chief Engr.

**ADHERE, INC.,**

1220 Maple Ave., Los Angeles, Calif.  
PERSONNEL: D. F. Dreher, Pres.; I. A. Anderson, V. Pres.-Sales; W. W. Clark, Secy. & Treas.; W. H. Hanson, Compt.; P. B. Crum, Pur. Agt.; J. F. Hefferon, Pers. Dir.; W. G. Marsh, D. Michaels, Engrs.

**ADJUSTABLE CLAMP CO.,**

417 N. Ashland Ave., Chicago, Ill.  
PERSONNEL: H. V. Holman, Pres.; D. V. Holman, Secy.

**ADVANCE ALUMINUM CASTINGS CORP.,**

2742 W. 36th Pl., Chicago, Ill.  
PERSONNEL: R. W. Wilson, Pres.; N. Shoon, Treas.; A. J. Peterson, Sales Mgr.; G. J. Ries, Pur. Agt.

**ADVANCE SPRING CORP.,**

1749 Carroll Ave., Chicago, Ill.  
PERSONNEL: F. C. Mueller, Pres.; D. E. Mielke, V. Pres., Treas & Gen. Mgr.; A. L. Mueller, Secy.; S. Banas, Chief Engr.

**AERCO CORP.,**

12024 Center, Hollydale, Calif.  
PERSONNEL: C. A. Herberts, Pres.; W. J. Merrigan, V. Pres. & Chief Engr.; E. T. Melone, V. Pres. & Sales Mgr.; L. A. Cole, Secy. & Treas.; C. B. Melone, Pur. Agt.; H. Hauffaire, Pers. Dir.

**AERO-COUPLING CORP.,**

1051 N. Hollywood Way, Burbank, Calif.  
PERSONNEL: A. A. Eisenman, Pres.; H. M. Davis, V. Pres., Treas. & Sales Mgr.; A. A. Burckle, Secy.; G. E. Farmer, Gen. Mgr. & Pers. Dir.; G. G. Bell, Prod. Mgr. & Pur. Dir.; R. C. Davis, Chief Engr.

**AERO ENGINEERING CORP.,**

525 N. Arlington Ave., E. Orange, N. J.  
PERSONNEL: E. A. Briner, Pres.; A. V. Bunnell, V. Pres.; J. Vulling, Secy. & Treas.

**AERO INDUSTRIES TECHNICAL INSTITUTE,** 5245 W. San Fernando Rd., Los Angeles 26, Calif.

PERSONNEL: R. Hemphill, Pres. & Gen. Mgr.; H. B. Harms, V. Pres., Sales Mgr. & Adv. Mgr.; P. W. Ivey, Secy. & Treas.; E. H. Peterman, Prod. Mgr.; A. Weisenborn, Pur. Dir.; H. R. Filson, Pers. Dir.; T. M. Shelton, Chief Engr.

**AERO PARTS MANUFACTURING CO.,**

INC., 411 E. English, Wichita, Kans.  
PERSONNEL: J. A. MacCullough, Pres. & Gen. Mgr.; D. W. Dawson, V. Pres.; J. E. Boyer, Secy.; R. E. Calvin, Treas.; L. H. Gunn, Pur. Agt.; N. Ingraham, Pers. Dir.

**AERO RESEARCH WIND TUNNEL CO.,**

126 Williams St., Farmingdale, N. Y.  
PERSONNEL: D. E. Olshevney, Pres. & Gen. Mgr.

**AERO SCREW CO.,**

19th Ave. & 12th St., Rockford, Ill.  
PERSONNEL: F. L. Hill, Pres.; L. L. Barr, Gen. Mgr.; S. H. Goranson, Sales Mgr.; K. J. Kollberg, Pur. Dir.; H. J. Rosenthal, Pers. Dir.

**AERO SPARK PLUG CO., INC.,**

161 Sixth Ave., New York 13, N. Y.  
PERSONNEL: W. E. Blood, Pres.; A. A. Kasarian, V. Pres. & Chief Engr.; S. Gundersen, Prod. Mgr.; H. A. Turnure, Sales Mgr. & Pers. Dir.; H. S. Van Cleve, Pur. Dir.

**AERO SUPPLY MFG. CO., INC.,**

Corry, Pa.  
PERSONNEL: F. N. Ames, Pres.; S. J. Irvine, V. Pres. & Gen. Mgr.; L. E. Graham, V. Pres. & Treas.; L. M. Kowalski, Supervisor of Sales; H. W. Jewell, Pur. Dir.; G. T. Downey, Chief Engr.

**AERO TOOL CO.,**

231 W. Olive Ave., Burbank, Calif.  
PERSONNEL: L. Deutsch, Pres.; P. Holzman, Gen. Mgr.; W. Rick, Sales Mgr.; A. Vienna, Pur. Agt.; C. Frankel, Pers. Dir.; K. Keesler, Chief Engr.

**AERO TRADES CO.,**

Roosevelt Field, Mineola, N. Y.  
PERSONNEL: J. G. McIntosh, E. Scheifele, Partners.

**AEROJET ENGINEERING CORP.,**

285 W. Colorado St., Pasadena 1, Calif.  
PERSONNEL: A. G. Haley, Pres.; F. Malina, Secy. & Treas.; T. E. Beehan, Gen. Mgr.; A. Acker, Prod. Mgr.; H. W. Johnston, Pur. Dir.; R. W. Cowden, Pers. Dir.; A. M. O. Smith, Chief Engr.

**AERONAUTICAL MFG. CORP.,**

377 Fourth St., Niagara Falls, N. Y.  
PERSONNEL: A. M. Patterson, Pres.; C. J. Lane, V. Pres., Gen. Mgr. & Chief Engr.; G. Jensvold, Secy.; J. J. Falbey, Pur. Agt.

**AERONAUTICAL PRODUCTS, INC.,**

18100 Ryan Rd., Detroit 12, Mich.  
PERSONNEL: A. Jackson, Pres. & Gen. Mgr.; C. C. Layman, V. Pres., Pub. Dir. & Adv. Mgr.; M. J. Whitfield, Secy.; B. M. Layman, Treas.; B. Stephenson, Prod. Mgr.; J. Domine, Factory Mgr.; E. C. Jonke, Sales Mgr.; C. S. Sharpstein, Pur. Dir.; E. M. Cahill, Pers. Dir.; W. Kazmier, Chief Engr.

**AERONAUTICAL RADIO MFG. CO.,**

155 First St., Mineola, N. Y.  
PERSONNEL: G. W. McCauley, Owner; L. A. Johnson, Secy.; E. Berliant, Gen. Mgr.; D. E. Whitten, Prod. Mgr.; L. D. Whitten, Pers. Dir.

# SERVING NOW ON SKYWAYS ALL OVER THE WORLD



**B. F. GOODRICH SILVERTOWNS**—"the safest airplane tires ever built"—High Pressure—Low Pressure—Smooth Contour—for landing, nose and tail wheels.



**B. F. GOODRICH DE-ICERS**—one of the greatest contributions to flying safety—now standard equipment on airliners and on many types of military aircraft.



**EXPANDER TUBE BRAKES**—Developed by B. F. Goodrich for greatly improved ground control—for take-offs and landings that are safer and smoother.

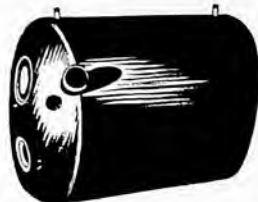

**BULLET SEALING FUEL CELLS**—Bullet Sealing Hose—Crash Pads, Grommets, Rivnuts, Gaskets, Oil-and-Gasoline-Resistant Synthetics.

**FIRST LINE OF FLIGHT**—These are just a few of the 80 different B. F. Goodrich products serving now in military, commercial, and private aircraft. Write for general catalog to The B. F. Goodrich Company, Aeronautical Div., Akron, O.

*Skyway or Highway*

**B.F. Goodrich**

**FIRST IN RUBBER**

**AEROPRODUCTS DIV., GENERAL MOTORS CORP.,** Municipal Airport, Dayton 1, O.

PERSONNEL: F. G. Wilson, Compt.; W. J. Blanchard, Gen. Mgr.; E. J. Parker, Prod. Mgr.; F. E. Lehman, Sales Mgr.; W. E. Kreitzer, Pur. Dir.; R. Daly, Pers. Dir.; J. Proud, Adv. Mgr.; C. S. MacNeil, Chief Engr.

**AEROPRODUCTS MANUFACTURING CO.,** 1625 Grand Ave., Kansas City, Mo.

PERSONNEL: C. W. Beck, Pres.; M. L. Beck, Secy.; L. Hay, Treas.; H. S. Sharpe, Gen. Mgr.; D. Baublits, Pur. Agt.; H. Wilder, Chief Engr.

**AEROQUIP CORP.,**

300 S. East Ave., Jackson, Mich.

PERSONNEL: D. T. McKone, Pres.; C. Hollerith, V. Pres.; F. W. Corwin, Secy. & Treas. & Pub. Dir.; M. W. Brandau, Gen. Mgr. & Chief Engr.; W. G. Howe, Pur. Agt.

**AGAWAM AIRCRAFT PRODUCTS, INC.,** Sag Harbor, N. Y.

PERSONNEL: A. P. Loening, Pres.; G. A. Dippel, Gen. Mgr.; A. M. Butts, Pur. Dir.

**AIR ASSOCIATES, INC.,** Bendix, N. J., Los Angeles, Calif., Chicago, Ill., Dallas, Tex.

PERSONNEL: H. I. Crow, Pres. & Sales Mgr.; R. E. Acre, V. Pres.; G. S. Klevestrom, Secy. & Treas.; C. E. Reid, Gen. Mgr.; P. Smith, Pur. Agt.; G. Evans, Pers. Dir.; E. A. Volk, Chief Engr.

**AIR COMMUNICATIONS, INC.,**

2233 Grand Ave., Kansas City 6, Mo.

PERSONNEL: H. S. Cole, Pres.; D. D. Darnell, V. Pres. & Gen. Mgr.; W. E. Payne, Secy. & Treas.; E. D. Smith, Chief Engr.

**AIR-CRAFT EQUIP. DIV. OF ANCHOR POST FENCE CO.,** 6500 Eastern Ave., Baltimore, Md.

PERSONNEL: W. F. Brannan, Pres.; R. D. Logee, V. Pres.; L. H. Johnson, Secy.; C. W. Burton, Jr., Treas.; T. H. Smoot, Gen. Mgr.; F. P. Harbin, Sales Mgr.; C. A. Bishop, Pur. Agt.; C. J. Gross, Pers. Dir.; M. J. Donahue, Pub. Dir.

**AIRCRAFTSMEN, INC.,**

223 Hindry Ave., Inglewood, Calif.

PERSONNEL: A. C. Chester, Pres.; A. P. Clausen, V. Pres.; Mrs. A. C. Chester, Secy. & Treas.

**AIR-MAZE CORP.,**

5200 Harvard Ave., Cleveland, O.

PERSONNEL: A. E. Schaaf, Pres.; O. H. Schaaf, V. Pres. & Gen. Mgr.; G. M. Walton, V. Pres.; L. M. Henton, Secy.; H. H. Schaaf, Treas.; F. M. Paul, Sales Mgr.; C. B. Moorhead, Pur. Agt.; W. B. Watterson, Pub. Dir.; P. C. Hungerford, Chief Engr.

**AIR-SHIELDS, INC.,**

County Line Rd., Hatboro, Pa.

PERSONNEL: S. Y. Gibbon, Pres.; T. T. Ludlum, V. Pres.; J. B. McPherson, IV, Secy.; B. C. Grieb, Treas. & Gen. Mgr.

**AIRCHOX CO. DIV. OF JOYCE AVIATION INC.,** 8 S. Michigan Ave., Chicago, Ill.

PERSONNEL: L. M. Lewis, Acting Pres. & Secy.; G. L. Chapman, V. Pres.; E. A. Joyce, Treas. & Gen. Mgr.; E. C. Joyce, Pur. Dir.; F. B. Wagner, Prod. Mgr.; F. C. Manson, Chief Engr.

**AIRCO TOOL CO.,**

1620 Euclid St., Santa Monica, Calif.

PERSONNEL: J. W. Sheehan, Pres.; H. W. Meister, Secy. & Treas.; D. R. Finnegan, Sales Mgr.; C. P. Edwards, Pur. Agt. & Pers. Dir.; H. W. Steel, Chief Engr.

**AIRCRAFT ACCESSORIES CORP., POWER CONTROLS DIV.,** 166 W. Olive Ave., Burbank, Calif.

PERSONNEL: R. C. Walker, Pres.; T. E. Colvin, Exec. V. Pres.; I. S. Wilson, V. Pres.-Finance; W. A. Cooke, V. Pres.-Ind. Rel.; O. R. Jones, Secy.; G. A. Rix, Serv. Mgr. & Control Engr.; R. E. Middleton, Chief Engr.; J. E. Nauman, Dir. of Pub. Rel.; J. Higbee, Dir. of Pur.

**AIRCRAFT ACCESSORIES CORP., ELECTRONICS DIV.,** Fairfax & Funston Rd., Kansas City, Kans.

PERSONNEL: R. C. Walker, Pres.; T. E. Colvin, Exec. V. Pres.; I. S. Wilson, V. Pres.-Finance; C. N. Kimball, V. Pres. & Exec. Engr.; O. R. Jones, Secy.; J. E. Nauman, Dir. of Pub. Rel.; H. Zimmerman, Dir. of Pur.

**AIRCRAFT COMPONENTS, INC.,**

8000 Woodley Ave., Van Nuys, Calif.

PERSONNEL: G. G. Budwig, Pres.; J. N. Combs, Exec. V. Pres. & Treas.; L. Comegas, V. Pres.; L. Zuhlke, Secy.; J. R. Bennet, Gen. Mgr.; K. J. Wilson, Sales Mgr. & Pub. Dir.; G. R. Wiseburg, Pur. Agt.; F. Schuck, Pers. Dir.; R. R. Rotzler, Chief Engr.

**AIRCRAFT CONTAINERS CO.,**

9001 S. Rayo Ave., South Gate, Calif.

PERSONNEL: J. A. Smith, Compt.; V. S. Breglio, Asst. Gen. Mgr., Sales Mgr., Pub. Dir. & Adv. Mgr.; T. J. Brock, Gen. Mgr.; F. H. Zehrbaugh, Prod. Mgr. & Chief Engr.; J. H. Wetterstrom, Pur. Dir.; L. O. Holter, Pers. Dir.

**AIRCRAFT ENGINEERING PRODUCTS, INC.,** 2 Ackerman Ave., Clifton, N. J.

PERSONNEL: A. G. Roth, Pres., Secy. & Chief Engr.; G. Roth, V. Pres., Pers. Dir. & Pub. Dir.; L. E. Amann, Treas.; J. H. Reiter, Gen. Mgr.; E. T. Den Bleyker, Pur. Agt.

**AIRCRAFT HARDWARE MFG. CO.,**

1381-91 Lafayette Ave., New York 59, N. Y.

PERSONNEL: E. Gordin, Secy.; O. Mazzei, Gen. Mgr.; S. Mazzei, Prod. Mgr.; F. di Biase, Sales Mgr.; E. Kinsky, Pur. Dir.; R. Kovats, Pers. Dir.

**AIRCRAFT INDICATORS CO.,**

742 S. Cooper St., Memphis 4, Tenn.

PERSONNEL: H. L. McPherson, Pres. & Chief Engr.

**AIRCRAFT INSTRUMENT SERVICE, INC.,**

11201 Conner, Detroit 5, Mich.

PERSONNEL: C. H. Rennwald, Pres.; B. Johnson, V. Pres.; A. V. Binard, Secy., Treas., Gen. Mgr., Pers. Dir. & Adv. Mgr.; F. M. Morten, Prod. Mgr.; G. J. Wendrick, Sales Mgr. & Pur. Dir.; C. F. West, Pub. Dir.; G. A. Silveira, Chief Engr.

**AIRCRAFT LUMBER CO.,**

250 E. Fifth St., St. Paul, Minn.

PERSONNEL: J. B. McGrath, Pres.

**AIRCRAFT & MARINE SPECIALTY CO.,**

302 S. Central Ave., Baltimore 2, Md.

PERSONNEL: J. R. Speer, Jr., Pres.; H. M. Short, V. Pres. & Chief Engr.; R. I. Welsh, V. Pres. & Prod. Mgr.; H. Hammond, Secy.; W. H. Meyer, Treas.; J. L. Bowdre, Jr., Pur. Dir.

**AIRCRAFT MECHANICS, INC.,**

3200 N. Nevada, Colorado Springs, Colo.

PERSONNEL: P. W. Nichols, Pres., Sales Mgr. & Chief Engr.; E. E. Nichols, V. Pres.; H. H. Holt, Secy.; M. A. Ohlander, Treas.; H. E. Jones, Prod. Mgr.; C. C. Woodard, Pur. Dir.; H. R. Elliott, Pers. Dir., Pub. Dir. & Adv. Mgr.



## *140,000 Persons Stopped, Looked and Listened!*

Tremendous crowds attending the Kansas City War Industries Show at the Municipal Auditorium last January, stood amazed at the demonstrations of Air Communications, Inc. Yet they saw only a small part of what this company is doing in the development of radio communications equipment for the United States Army and Navy.

At present, Air Communications, Inc. is 100% busy on War Work . . . furnishing secret, vital communication needs for men on the battle fronts and on ships at sea.

Tomorrow, when peaceful days return, this and other scientifically developed communications equipment will be ready for the aircraft manufacturers and air transportation lines of the nation . . . to bring greater safety, added comfort and to save time.

Watch Air Communications, Inc. when Victory comes!

**AIR COMMUNICATIONS, INCORPORATED**

2233 Grand Ave.

Kansas City, Mo.



**AIRCRAFT PARTS DEVELOPMENT CORP.,**  
409 Broad St., Summit, N. J.

PERSONNEL: D. C. Hungerford, Pres. & Treas.; L. M. Hungerford, V. Pres.; H. T. Hungerford, Secy.; M. Christensen, Pur. Agt.

**AIRCRAFT PRODUCTION ENGINEERS,**  
1834-42 W. 59th St., Chicago, Ill.

PERSONNEL: R. G. Hilger, Pres., Gen. Mgr. & Sales Mgr.; L. Bremer, Treas.; D. King, Pers. Dir.; J. Polan, Chief Engr.

**AIRCRAFT PRODUCTS CO.,**  
Franklin & Lacey Sts., W. Chester, Pa.

PERSONNEL: E. K. Gray, J. H. Stephens, Owner-Manager; F. K. McFyier, Compt.; G. B. Smith, Factory Mgr.; C. J. Fuller, Dev. Engr.

**AIRCRAFT PRODUCTS, INC.,**

660 Union Ave., Memphis 3, Tenn.

PERSONNEL: E. M. Knoff, Pres.; J. E. Johnson, V. Pres.; J. W. S. Boone, Secy.; W. Barros, Treas.

**AIRCRAFT RADIO CORP.,** Boonton, N. J.

PERSONNEL: L. M. Hull, Pres. & Gen. Mgr.; F. H. Drake, V. Pres. & Chief Engr.; B. E. Holley, Secy., Treas. & Adv. Mgr.; J. E. Johanson, V. Pres. & Prod. Mgr.; M. M. Eells, Sales Mgr.; H. M. Kingsland, Pur. Dir.; J. A. Pierce, Pers. Dir.; E. M. Hezlitt, Pub. Dir.

**AIRCRAFT SCREW PRODUCTS CO., INC.,**  
47-23 35th St., Long Island City 1, N. Y.

PERSONNEL: B. Sack, Pres. & Gen. Mgr.; H. W. Cram, V. Pres. & Sales Mgr.; J. J. Sack, Asst. V. Pres.; A. L. Salkin, Secy.; C. L. Huisking, Jr., Treas.; H. J. Wrigley, Pur. Dir.; E. M. Lang, Pers. Dir.; C. G. Thoma, Pub. Dir.; O. Haas, Chief Engr.

**AIRCRAFT SPECIALTIES CO.,**

601 S. Anderson St., Los Angeles, Calif.

PERSONNEL: J. L. Hastings, Pres. & Gen. Mgr.; B. A. Berthelsen, V. Pres. & Pers. Dir.; C. LaTourrette, Secy.; F. Pulfer, Treas.; T. K. Temple, Sales Mgr. & Pub. Dir.; G. McGhie, Pur. Agt.; P. E. Shafer, Chief Engr.

**AIRCRAFT STANDARD PARTS CO.,**

1711 19th Ave., Rockford, Ill.

PERSONNEL: H. V. Snyder, Pres.; F. L. Hill, Gen. Mgr.; T. R. St. Claire, Pur. Agt.

**AIRCRAFT TOOLS, INC.,**

750 E. Gage Ave., Los Angeles, Calif.

PERSONNEL: W. Miller, Pres.; E. Miller, V. Pres.; G. LaFollette, Secy.; J. Glassman, Sales Mgr.; B. Stevens, Pur. Agt.; D. Watson, Chief Engr.

**AIRCRAFT WELDERS, INC.,**

403 Beacon Bldg., Wichita, Kans.

PERSONNEL: O. A. Sutton, Pres.; H. T. Fleeson, W. P. Innes, Jr., V. Pres.; W. J. Lyons, Treas.; W. H. Krupp, Prod. Mgr.; E. M. Evans, Pur. Dir.; O. B. Chandler, Pers. Dir.

**AIRDESIGN & FABRICATION, INC.,**

241 Fairfield Ave., Upper Darby, Pa.

PERSONNEL: L. E. Pamphilon, Pres. & Chief Engr.; W. C. Faust, V. Pres. & Treas.; L. D. Pamphilon, Secy.; W. R. Keenly, Prod. Mgr.; L. R. Dieterich, Sales Mgr. & Pur. Dir.

**AIRESEARCH MANUFACTURING CO.,**

9851 Sepulveda Blvd., Los Angeles 43, Calif.

PERSONNEL: J. C. Garrett, Pres.; W. Brownlee, V. Pres. & Gen. Mgr.; M. Gelber, Secy.; W. D. Morgan, Treas.; J. Rosales, Prod. Mgr.; R. J. Hostetter, Sales Mgr.; J. B. Meyer, Pur. Dir.; J. Tutthill, Pers. Dir.; C. W. Reynolds, Pub. Dir. & Adv. Mgr.; W. R. Ramsaur, Chief Engr.

**AIRPLANE MANUFACTURING & SUPPLY CORP.,** 409 N. Brand Blvd., Glendale 3, Calif.

PERSONNEL: E. Herring, Pres. & Gen. Mgr.; R. D. Laco, Jr., V. Pres.; E. O. Locher, Secy., Treas. & Asst. Gen. Mgr.; K. R. Jameson, V. Pres.-Sales; R. J. Patterson, Pur. Agt.; F. V. Shuck, Pers. Dir.; E. F. Dixon, Adv. Mgr.

Manufacturing Div.,  
6853 Lankershim Blvd.,  
N. Hollywood, Calif.

PERSONNEL: E. B. Anderson, Mgr.; R. A. Gageby, Prod. Mgr.

**AIRSEALAND AIRCRAFT, INC.,**

25-17 43rd Ave., Long Island City, N. Y.

PERSONNEL: R. Decat, Pres. & Chief Engr.; L. Levez, Secy.; G. Decat, Treas.; G. Becker, Pers. Dir.

**AJAX ELECTROTHERMIC CORP.,**

Trenton, N. J.

PERSONNEL: G. H. Clamer, Pres.; R. N. Blakelee, V. Pres.; F. T. Chesnut, Secy.; A. D. Meyer, Treas.

**ALADDIN RADIO INDUSTRIES, INC.,**

501 W. 35th St. Chicago, Ill.

PERSONNEL: V. S. Johnson, Pres.; J. C. McGinley, V. Pres. & Gen. Mgr.; F. N. Jacob, Chief Engr.

**THE ALBANO CO., INC.,**

306 E. 47th St., New York, N. Y.

PERSONNEL: P. Albano, Pres. & Treas.; E. Albano, V. Pres. & Secy.

**ALCO VALVE CO.,** St. Louis, Mo.

PERSONNEL: A. B. Schellenberg, Pres.; B. Deutsch, Prod. Mgr.; R. S. Dawson, Sales Mgr.; J. E. Dube, Chief Engr.

**THE ALEXANDER MILBURN CO.,**

1416 W. Baltimore St., Baltimore 23, Md.

PERSONNEL: A. F. Jenkins, Pres.; W. L. Lawrence, V. Pres. & Sales Mgr.; M. D. Maguire, Secy.; E. R. Kaneley, Pur. Dir.; L. E. Jones, Jr., Adv. Mgr.

**ALL AMERICAN AIRCRAFT PRODUCTS, INC.,** 1350 E. Anaheim St., Long Beach, Calif.

PERSONNEL: E. Adler, Pres. & Gen. Mgr.; G. R. Adler, V. Pres.; H. D. Lawrence, Secy.; C. F. Lindquist, Treas.; W. R. Bennet, Sales Mgr.; C. F. Bittel, Pur. Agt.; R. C. Adler, Chief Engr.

**ALL AMERICAN TOOL & MFG. CO.,**

1014 Fullerton Ave., Chicago 14, Ill.

PERSONNEL: R. O. Hein, Chief Engr.; S. K. Hein, Pur. Agt.

**ALL WEATHER SPRINGS,**

140 Cedar St., New York 6, N. Y.

PERSONNEL: J. W. Rockefeller, Jr., Gen. Mgr.

**ALLEGHENY LUDLUM STEEL CORP.,**

Brackenridge, Pa.

PERSONNEL: H. G. Batcheller, Pres.; W. A. Givens, V. Pres.; E. J. Hanley, Secy. & Treas.; R. M. Allen, Sales Mgr.; L. H. Bittner, Pur. Dir.; R. C. Edgar, Pers. Dir.; C. B. Templeton, Adv. Mgr.; E. L. Huff, Chief Engr.

**ALLEN ELECTRIC AND EQUIPMENT CO.,**

2101-29 N. Pitcher St., Kalamazoo, Mich.

PERSONNEL: G. H. Allen, Pres., Gen. Mgr. & Chief Engr.; L. F. Woolman, V. Pres. & Sales Mgr.; M. E. McMartin, Secy.; A. J. Higdon, Treas.; R. H. Aldrich, Pur. Agt.; L. Feltes, Pers. Dir.; K. Fullerton, Pub. Dir.

**Used on America's Leading Aircraft!**



NO. 732-A

**MACWHYTE COMPANY**

*KENOSHA, WISCONSIN*

*Manufacturers of "Hi-Fatigue" Aircraft Cable,  
"Safe-Lock" Cable Terminals, Aircraft*

*Tie-Rods, Braided Wire Rope Slings, Monel Metal and  
Stainless Steel Wire Rope, and wire rope for all requirements*

**THE ALLEN MANUFACTURING CO.,**  
133 Sheldon St., Hartford, Conn.

PERSONNEL: H. R. Grant, Pres.; E. Dimock, V. Pres.; F. J. Whitney, Secy.; S. K. Dimock, Treas.; J. C. Osmond, Gen. Mgr.; W. C. Waldo, Sales Mgr.; M. C. Uricchio, Pur. Agt.; E. S. Grant, Pers. Dir.; R. W. Bidwell, Pub. Dir.; C. S. Gates, Chief Engr.

**ALLIED AVIATION CORP.,**  
Baltimore, Md.

PERSONNEL: R. E. Breed, III, Pres.; C. J. MacGarvey, V. Pres. & Treas.; E. V. Chart-rand, Secy.; J. C. Richardson, Prod. Mgr.; J. C. Gaffin, Sales Mgr.; A. Arendt, Pur. Dir.; R. R. Scott, Pers. Dir.; L. L. Collins, Chief Engr.

**ALLIED CONTROL CO., INC.,**  
2 East End Ave., New York 21, N. Y.

PERSONNEL: E. H. Gillette, Ch.; J. E. Ebert, Pres.; J. M. Coffeen, V. Pres.; D. A. Calder, Sales Mgr.; S. J. Gallay, Adv. Mgr.

**ALLIED ENGINEERING CORP.,**  
1315 Chapel St., New Haven, Conn.

PERSONNEL: A. L. Patterson, Pres.; R. T. Crane, Jr., Secy. & Treas.; R. K. T. Steele, Exec. Engr.

**ALLIS-CHALMERS MFG. CO.,**  
Milwaukee 1, Wisc.

PERSONNEL: W. Geist, Pres.; H. W. Story, J. A. Keogh, V. Pres.; L. H. Hill, V. Pres. & Pers. Dir.; E. H. Brown, V. Pres. & Chief Engr.; W. E. Hawkinson, Secy. & Treas.; J. M. White, Gen. Mgr.; W. C. Johnson, Sales Mgr.; F. E. Haker, Pur. Dir.; G. J. Callos, Pub. Dir. & Adv. Mgr.

**ALLOYS FOUNDRY INC.,**  
301 N. St. Francis St., Wichita, Kans.

PERSONNEL: O. A. Sutton, Pres.; W. P. Innes, V. Pres.; W. J. Lyons, Secy. & Treas.; L. E. Thomure, Gen. Mgr. & Pur. Dir.; G. E. Doyle, Prod. Mgr. & Pers. Dir.

**ALOFS MANUFACTURING CO.,**  
1615 Madison Ave., S. E., Grand Rapids 7, Mich.

PERSONNEL: H. G. Alofs, Gen. Mgr.; L. A. Alkema, Pur. Dir.

**ALPHA METALS, INC.,**  
363 Hudson Ave., Brooklyn 2, N. Y.

PERSONNEL: H. Shonberg, Pres.; P. Tort, Prod. Mgr.; B. Morris, Adv. Mgr.

**ALUMINUM COMPANY OF AMERICA,**  
Gulf Bldg., Pittsburgh 19, Pa.**ALUMINUM GOODS MFG. CO.,**  
Manitowoc, Wisc.

PERSONNEL: A. J. Vits, Pres. & Gen. Mgr.; H. L. Vits, V. Pres.; E. O. Vits, V. Pres. & Prod. Mgr.; W. F. B. Bugenhagen, V. Pres. & Gen. Sales Mgr.; R. H. Fulton, Secy. & Treas.; R. X. Stiefvater, Aviation Sales Mgr.; H. W. Vits, Pur. Dir.; R. L. Pritchard, Adv. Mgr.; C. O. Schmidt, Chief Engr.

**ALUMINUM INDUSTRIES, INC.,**  
2438 Beekman St., Cincinnati 25, O.

PERSONNEL: J. Eckerle, Pres.; H. J. Hater, V. Pres., Treas. & Gen. Mgr.; R. T. Mesker, Secy.; M. A. Beckmann, Asst. Gen. Mgr.; E. F. Eckerle, Pur. Dir.; E. E. Heinze, Pers. Dir.; B. V. Keller, Pub. Dir. & Adv. Mgr.; W. J. Brinkman, Chief Engr.

**ALUMINUM LADDER CO., Worthington, Pa.**

PERSONNEL: S. H. Carbis, Pres. & Gen. Mgr.; E. A. McCarthy, Secy.; J. G. Campbell, Treas.; D. D. Cramer, Pur. Agt.

**AMERICAN AIR FILTER CO., INC.,**  
215 Central Ave., Louisville, Ky.

PERSONNEL: W. M. Reed, Pres.; H. C. Murphy, V. Pres.; B. J. Shayer, Treas.; J. Hellstrom, Gen. Mgr.; G. W. Sonntag, Sales Mgr.; L. Greenebaum, Pur. Agt.; B. A. Taylor, Pers. Dir.; J. R. McConnell, Pub. Dir.; C. P. Hegan, Chief Engr.

**AMERICAN AIRPORT EQUIPMENT CO.,**  
5958-60 Washington Blvd., Chicago, Ill.

PERSONNEL: G. F. Kelly, Owner.

**AMERICAN ALUMINUM WARE CO.,**  
368 Jelliff Ave., Newark, N. J.

PERSONNEL: H. Brucker, Pres.; J. B. Klausmann, V. Pres., Treas. & Sales Mgr.; F. T. Blackely, Secy. & Pur. Agt.; M. H. Klausmann, H. J. Brucker, Engineers.

**AMERICAN ARMAMENT CORP.,**  
6 E. 45th St., New York, N. Y.

PERSONNEL: A. J. Miranda, Jr., Pres.; W. A. Smith, V. Pres.; I. J. Miranda, V. Pres. & Treas.; F. W. Zelcer, V. Pres. & Sales Mgr.; D. H. Deppen, Secy.; J. Z. Kaplan, Pur. Agt.; J. J. McGann, Pers. Dir.; J. L. Mott, Pub. Dir.; W. S. Haines, Chief Engr.

**THE AMERICAN AUTO PARTS CO.,**  
919 Bonham Ave., Columbus 3, O.

PERSONNEL: L. Lewis, Pres. & Pers. Dir.; L. B. Keyser, V. Pres.; W. T. Lewis, Secy., Gen. Mgr. & Sales Mgr.; O. L. Gibson, Treas.; F. G. Gibson, Prod. Mgr.; P. D. Conley, Pur. Dir.

**AMERICAN BOSCH CORP.,**  
3664 Main St., Springfield, Mass.

PERSONNEL: D. P. Hess, Pres.; F. N. Perry, E. H. Moll, W. K. Dow, M. Berlyn, V. Pres.; R. A. Wickes, Secy. & Treas.; W. T. Barton, Pur. Agt.; C. L. Shedd, Mgr., Ser. Sales Div.; R. J. Alden, Adv. Mgr.; B. Loeffler, Chief Engr.

**AMERICAN CHEMICAL PAINT CO.,**  
Ambler, Pa.

PERSONNEL: L. Cherksey, Pres. & Gen. Mgr.; F. P. Spruance, V. Pres. & Sales Mgr.; H. D. Steinbright, Secy., Prod. Mgr. & Pur. Dir.; E. H. Rishel, Treas.; W. B. Boyer, Adv. Mgr.

**AMERICAN CENTRAL MANUFACTURING CORP.,** Connersville, Ind.

PERSONNEL: S. P. Jones, Pres.; E. O. Johnson, N. C. Ferreri, V. Pres.; E. G. Meldrum, Secy.; E. C. Wilkinson, Sales Mgr.; E. G. Husselman, Pur. Agt.; J. Hendrickson, Pub. Dir.; W. L. Foskett, Chief Engr.

**AMERICAN CHAIN & CABLE CO., INC.,**  
929 Connecticut Ave., Bridgeport 2, Conn.

PERSONNEL: W. T. Morris, Pres.; W. F. Wheeler, Exec. V. Pres. & Treas.; G. C. Moon, V. Pres.-Sales; C. N. Johns, V. Pres.-Operations; W. D. Kirkpatrick, V. Pres.; W. M. Wheeler, Secy.; D. Fleming, Pur. Dir.; J. O. Lashar, Adv. Mgr.; E. V. Creagh, Sales Promotion Mgr.

**AMERICAN CORD & WEBBING CO., INC.,**  
374 Broadway, New York, N. Y.

PERSONNEL: M. Krauss, Pres.; J. Krauss, V. Pres.; E. Krauss, Secy.; M. Krauss, Treas.; J. L. Bamberger, Sales Mgr.

**AMERICAN FOUNDRY & FURNACE CO.,**  
Bloomington, Ill.

PERSONNEL: H. A. Soper, Pres., Gen. Mgr. & Sales Mgr.; L. G. Whitmer, V. Pres. & Treas.; R. P. Whitmer, Secy.; E. L. Fox, Pur. Dir.; W. J. Klingberg, Chief Engr.



**"SO THAT'S THE NORTH POLE!"**

Soon the North Pole will need a marker — adequate identification for the postwar passengers on polar routes who'll want to tell their friends they've really seen it. Meanwhile American Bosch sticks to its war jobs — starting vibrators for positive ignition at all temperatures from equator to the arctic circle — aviation magnetos that have helped modern aircraft engines maintain service ceilings of seven miles and more — gasoline injection equipment that saves fuel, steps up pay load, increases engine performance and round trip military range. Whether the future will demand more and more production for military needs or a rapid changeover to transports for polar and other global routes, in research, design and production, American Bosch will continue to serve all branches of the internal combustion industry.

*American Bosch Corporation • Springfield, Mass.*



**AMERICAN BOSCH**

AVIATION AND AUTOMOTIVE ELECTRICAL PRODUCTS . . .  
FUEL INJECTION EQUIPMENT

**AMERICAN FOUNDRY EQUIPMENT CO.,**  
301 S. Byrkit St., Mishawaka, Ind.

PERSONNEL: O. A. Pfaff, Pres. & Gen. Mgr.; L. L. Andrus, V. Pres. & Sales Mgr.; H. M. Miller, Secy. & Treas.; H. O. Books, Pur. Agt.; A. E. Lenhard, Pub. Dir.; D. C. Turnbull, Chief Engr.

**AMERICAN GAS ACCUMULATOR CO.,**  
1029 Newark Ave., Elizabeth, N. J.

PERSONNEL: L. M. Merrill, Pres.; J. B. Rhodes, V. Pres.; W. F. Burk, Secy. & Treas.; I. J. Mack, Gen. Mgr.; R. E. Joubert, Pur. Agt.; V. L. Oestnaes, Chief Engr.

**AMERICAN HAIR & FELT CO.,**

Merchandise Mart, Chicago, Ill.

PERSONNEL: N. S. McKay, Pres. & Treas.; L. C. Scott, V. Pres.; M. A. Kemper, Secy.; C. H. Rayner, Gen. Mgr.; W. J. Berry, Sales Mgr.; W. A. Busch, Pur. Agt.; R. A. Phelps, Pub. Dir.; R. S. Phillips, Chief Engr.

**AMERICAN HAMMERED PISTON RING DIV. KOPPERS CO.,** Baltimore, Md.

PERSONNEL: P. Williams, Pres.; A. W. Morton, V. Pres. & Gen. Mgr.; J. A. Worthington, Sales Mgr.; L. Palmer, Pur. Agt.; E. B. Whitman, Pers. Dir.; T. L. Ford, Pub. Dir.; E. Stead, Chief Engr.

**AMERICAN HARD RUBBER CO.,**

11 Mercer St., New York 13, N. Y.

PERSONNEL: F. D. Hendrickson, Pres.; A. V. Bristol, V. Pres. & Treas.; R. Harry, Secy.; G. B. Glaenger, Sales Mgr.; A. P. House, Pur. Dir.; O. B. Carson, Adv. Mgr.  
Plants: Akron, O.; Butler, N. J.

**AMERICAN INSTRUMENT CO., 8030-8040**  
Georgia Ave., Silver Spring, Md.

PERSONNEL: L. Freeman, Pur. Agt.; W. H. Reynolds, Chief Engr.; C. L. Schuettler, Sales Mgr. & Pub. Dir.

**AMERICAN-LAFRANCE-FOAMITE CORP.,**  
Elmira, N. Y.

PERSONNEL: E. E. O'Neill, Pres.; C. F. Smith, V. Pres.; C. A. Pettyjohn, Secy. & Treas.; J. O. Binford, Sales Mgr.; F. R. Baker, Pur. Agt.; L. C. Hogg, Pers. Dir.; C. H. Lindsay, Chief Engr.

**AMERICAN MACHINE AND METALS, INC.,**  
East Moline, Ill.

PERSONNEL: P. G. Mumford, Pres.; J. C. Vander Pyl, V. Pres. & Gen. Mgr.; C. A. Force, Secy.; H. T. McMeekin, Treas.; J. Kotez, Prod. Mgr.; W. Mendell, Sales Mgr.; S. H. Dekker, Pur. Dir.; J. Swennumson, Pers. Dir.; R. W. Denman, Pub. Dir. & Adv. Mgr.; C. W. Anderson, Chief Engr.

**AMERICAN MAGNESIUM CORP.,**

2210 Harvard Ave., Cleveland, O.

PERSONNEL: W. Brown, V. Pres. & Gen. Mgr. W. G. Harvey, Sales Mgr.

**AMERICAN NICKELOID CO., Peru, Ill.**

PERSONNEL: F. M. Maze, Pres.; C. C. Struever, V. Pres. & Gen. Mgr.; J. Maze, Secy.; H. Maze, Treas.; C. B. Meng, Pur. Agt.

**AMERICAN OIL & SUPPLY CO.,**

238 Wilson Ave., Newark, N. J.

PERSONNEL: W. Ulrich, Pres.; H. A. Dwyer, V. Pres. & Secy.; E. F. Hoffmann, V. Pres. & Treas.; L. W. Schreihofner, Sales Mgr.; W. M. Hoffmann, Pur. Agt.

**AMERICAN PAULIN SYSTEM,**

1847 S. Flower St., Los Angeles, Calif.

PERSONNEL: A. F. Munter, Pres. & Gen. Mgr.; H. A. Munter, V. Pres.; C. J. Petrovich, Secy. & Treas.; E. G. Larson, Chief Engr.

**AMERICAN PHENOLIC CORP.,**

1830 S. 54th Ave., Chicago, Ill.

PERSONNEL: A. J. Schmitt, Pres. & Gen. Mgr.; D. Alexander, V. Pres.; C. V. Wisner, Secy.; A. Dushek, Treas.; W. Rous, Sales Mgr.; E. G. Johnson, Pur. Agt.; M. A. Donlon, Pers. Dir.; C. Quackenbush, Chief Engr.

**AMERICAN PHOTOCOPIY EQUIPMENT**  
CO., 2849 N. Clark St., Chicago 14, Ill.

PERSONNEL: J. S. Lederer, A. L. Creange, Partners; E. Floun, Pur. Dir.; H. J. Weinberg, Adv. Mgr.

**AMERICAN PLYWOOD CORP.,**

New London, Wisc.

PERSONNEL: F. L. Zaug, Pres.; D. F. Zaug, V. Pres. & Prod. Mgr.; H. M. Zaug, Treas., Sales Mgr. & Adv. Mgr.; W. S. Park, Chief Engr.

**AMERICAN PROPELLER CORP., Toledo, O.**

PERSONNEL: W. F. Wise, Pres.; E. R. Isbell, Asst. to Pres.; I. J. Snader, V. Pres.-Mfg.; W. A. Mogensen, V. Pres. & Treas.; W. N. Wood, Plant Mgr.; R. J. Cowden, Contract & Service Engr.; D. T. Waltz, Pur. Agt.; W. R. Hanna, Pers. Mgr.; D. R. Woolf, Chief Engr.

**AMERICAN ROOF TRUSS CO.,**

6850 Stony Island Ave., Chicago 49, Ill.

PERSONNEL: W. H. Waddington, Pres. & Treas.; T. Bensen, V. Pres.; E. F. Waddington, Secy.; W. H. Waddington, Jr., Sales Mgr.; M. R. Brosius, Pur. Dir.; R. J. Waddington, Adv. Mgr.; W. A. Reinert, Chief Engr.

**AMERICAN SCREW CO.,**

21 Stevens St., Providence 1, R. I.

PERSONNEL: P. C. Nicholson, Pres.; J. F. Doherty, Secy.; E. W. Lane, Treas.; C. O. Drayton, Gen. Mgr.; A. McTague, Prod. Mgr.; W. A. Smedley, Pur. Dir.; J. A. Beaugard, Pers. Dir.; H. Mayoh, Adv. Mgr.; F. E. Brown, Chief Engr.

**AMERICAN SCREW PRODUCTS,**

7000 Avalon Blvd., Los Angeles, Calif.

PERSONNEL: A. Deutsch, Gen. Mgr.; R. H. Cumins, Prod. Mgr.; D. Herington, Sales Mgr.; J. Manderbach, Pur. Dir.; H. Matlaf, Pers. Dir.; C. Jones, Adv. Mgr.; A. Bowlzer, Chief Engr.

**AMERICAN STAMPING & MFG. CO.,**

320 Sunset Ave., Venice, Calif.

PERSONNEL: R. C. King, Pres.; A. F. Deahl, Exec. V. Pres.; J. H. Kramer, V. Pres. & Gen. Mgr.; C. B. Kramer, Secy. & Treas.; J. R. Mohr, Pur. Dir.; S. F. Alexander, Pers. Dir.; K. H. Karlsson, Chief Engr.

**AMERICAN STEEL & WIRE CO.,**

614 Superior Ave., N. W., Cleveland 13, O.

PERSONNEL: C. F. Hood, Pres.; F. Carr, V. Pres.-Finance; H. B. Jordan, V. Pres.-Production; J. May, V. Pres. & Gen. Sales Mgr.; J. G. Nelson, Secy.; R. E. Lewis, Treas.; F. E. Chesney, Pur. Dir.; F. J. Burt, Ind. Rel. Dir.; W. I. Ong, Pub. Dir.; W. H. Cordes, Adv. Mgr.; G. Rose, Chief Engr.

**THE AMERICAN TOOL WORKS CO.,**

Pearl & Eggleston Aves., Cincinnati, O.

PERSONNEL: L. W. S. Alter, Pres.

**AMERICAN TUBE BENDING COMPANY, INC.,** 5 Lawrence St., New Haven, Conn.

PERSONNEL: H. W. Jones, Jr., Pres., Treas. & Gen. Mgr.; B. Smith, V. Pres.; F. B. Kingsbury, V. Pres., Sales Mgr. & Adv. Mgr.; E. W. Stolz, Secy.; D. F. Bradley, Prod. Mgr.; A. F. Cewe, Pur. Dir.; R. H. Hanabury, Pers. Supt.; E. Helwig, Chief Engr.

MAKE THEM MORE AND MORE AUTOMATIC

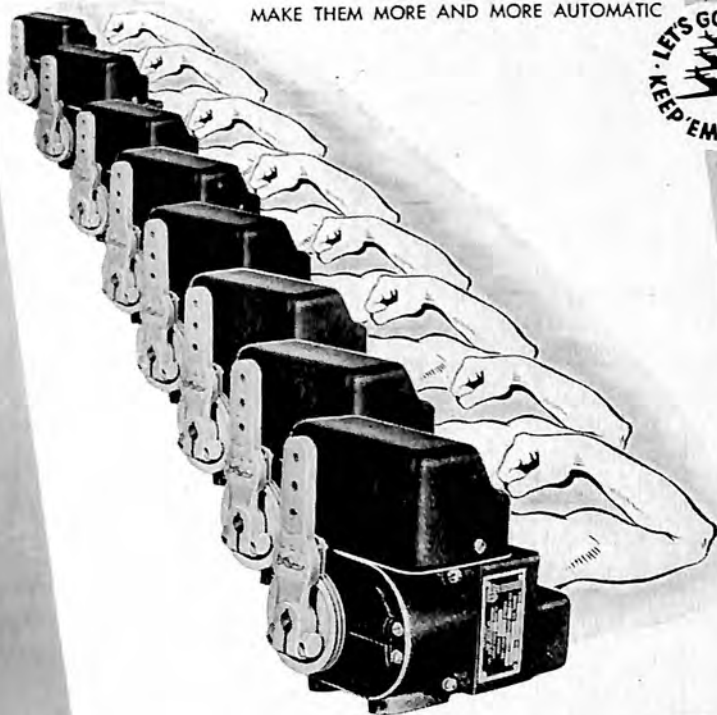

**EXTRA ARMS FOR THE PILOT**

Wishing for "extra arms" won't help a pilot in a tough spot. Since modern military planes are so complex, the compact high energy of White-Rodgers motorized temperature controls automatically takes care of conditions otherwise requiring attention of the airplane's crew.

Such assemblies can be adapted specifically to your design requirements for every application involving automatic temperature regulation, by local or remote control.

Engineering data will be furnished to manufacturers on request.

**WHITE-RODGERS ELECTRIC CO.**



SAINT LOUIS, MO.



# HUB

## INDUSTRIES, INC.

*formerly* DOWTY EQUIPMENT CORPORATION

*Specialists in*

LANDING GEAR & HYDRAULIC EQUIPMENT FOR AIRCRAFT

LONG ISLAND CITY · NEW YORK

# APEX

## *TOOLS for* *Aircraft Production*

- *Universal Joint Socket Wrenches*
- *Power Bits and Hand Drivers for Phillips screws*
- *Power Bits for Slotted Head screws*
- *Specialized tools for drilling, tapping, reaming, boring, stud and nut setting.*
- *Aircraft Universal Joints to A N Drawing 270 and 271*

*Write for Catalogs*

**THE APEX MACHINE  
and TOOL COMPANY**

**Dayton, Ohio.**

# AIRCRAFT METAL PARTS

*and*

## SUB-CONTRACT PRODUCTION

*Please forward blueprints  
for estimates*

# JOWEIN, INC.

## METAL PRODUCTS

JAMAICA, NEW YORK

# Speedy, Tight Fastenings made by AMERICAN PHILLIPS SCREWS

*meet all Battle-Tests  
on Today's Planes*



*Phillips Driver-point fits snugly in tapered recess—WON'T SLIP OUT—permits high-speed driving.*



With American Phillips Screws, unskilled men and women are making aircraft assemblies faster and stronger than skilled labor can make them with slotted screws.

**American Phillips Screw Driving is quick and effortless:**

1. Place the point of the Phillips Screw Driver Bit in the Phillips Recess (bit centers automatically).
2. Aim the driver with one hand. Other hand holds the work.
3. Press the power driver trigger . . . another American Phillips Screw driven straight and tight, with its head unburred and the work-surface unmarred. The Phillips driver can't slip out of the Phillips Recessed Head . . . can't sit any way but straight in the tapered recess. So women and inexperienced men hit top output at

once, without undue fatigue or lost time accidents. Production records and battle records prove American Phillips Screws to be among the powerful weapons of this war . . . *for they make time fight on our side.*

**AMERICAN SCREW COMPANY**  
*Providence 1, Rhode Island*

---

CHICAGO 11                      DETROIT 2  
 589 E. Illinois Street          502 Stephenson Bldg.

**BUY WAR BONDS!**

**AMPCO METAL, INC.,**

1745 S. 38th St., Milwaukee 4, Wisc.  
 PERSONNEL: C. J. Zaiser, Pres. & Gen. Mgr.; R. Kunz, V. Pres.; R. W. Uecker, Secy. & Treas.; G. K. Dreher, Prod. Mgr.; B. J. Bickel, Sales Mgr.; C. Dawley, Pur. Dir.; J. E. Johnson, Pers. Dir.; G. S. Hamilton, Adv. Mgr.; H. Brink, Chief Engr.

**ANCHOR POST FENCE CO.,**

6500 Eastern Ave., Baltimore 24, Md.  
 PERSONNEL: W. F. Brannan, Pres.; T. H. Smoot, V. Pres. & Chief Engr.; G. B. Ferris, Secy.; C. W. Burton, Jr., Treas.; J. S. Case, Prod. Mgr.; C. W. Bishop, Pur. Dir.; C. J. Gross, Pers. Dir.; M. J. Donahue, Pub. Dir. & Adv. Mgr.

**ANDERSON BROS. MANUFACTURING CO.,**

1907 Kishwaukee St., Rockford, Ill.  
 PERSONNEL: S. F. Anderson, Pres.; V. L. Spencer, V. Pres.; R. F. Anderson, Secy., Treas. & Adv. Mgr.; B. C. Olson, Prod. Mgr.; W. E. Gunnerson, Sales Mgr.

**ANDOVER MOTORS CORP.,**

999 S. Main St., Elmira, N. Y.  
 PERSONNEL: J. J. Brooks, Pres.; C. H. Wadsworth, V. Pres. & Treas.; W. M. Huber, Secy.; V. P. Mathews, Factory Mgr.; A. E. Hill, Prod. Mgr.; R. G. Valentine, Pur. Dir.; R. S. Phillips, Pers. Dir.; M. D. Hanes, Chief Engr.

**ANDREWS & PERILLO, INC., 39-30 Crescent St., Long Island City, N. Y.**

PERSONNEL: F. J. Perillo, Pres., Treas. & Chief Engr.; L. Peirez, Secy.; B. Peirez, Gen. Mgr. & Pur. Agt.; M. Wagner, Pub. Dir.

**ANEMOSTAT CORP. OF AMERICA,**

10 E. 39th St., New York, N. Y.  
 PERSONNEL: A. Rust-Oppenheim, Pres.; F. J. Kurth, V. Pres.; J. C. Anderer, Treas.; J. B. Hewett, Sales Mgr.; F. Honerkamp, Chief Engr.

**ANGELUS STEEL TREATING CO.,**

2229 E. 38th St., Los Angeles 11, Calif.  
 PERSONNEL: C. O. Thrasher, S. R. Earl, Partners; J. R. Cerato, Gen. Mgr. & Prod. Mgr.

**ANGIER SALES CORP., Framingham, Mass.**

PERSONNEL: O. Angier, Pres.; A. J. Thiel, V. Pres. & Sales Mgr.; J. M. Angier, Treas.; F. Bowker, Pur. Agt.; N. W. Forrest, Pub. Dir.; E. R. Dearborn, Chief Engr.

**R. B. ANNIS CO.,**

1101 N. Delaware St., Indianapolis 2 Ind.  
 PERSONNEL: R. B. Annis, Gen. Mgr.; R. K. Caskey, Pur. Dir.

**ANTI-CORROSIVE METAL PRODUCTS CO., INC., Castleton-on-Hudson, N. Y.**

PERSONNEL: E. F. Bainbridge, Pres., Treas. & Gen. Mgr.; J. Kapner, Secy.; E. Cameron, Pur. Dir.; F. Saunders, Chief Engr.

**THE APEX MACHINE & TOOL CO.,**

1025 S. Patterson Blvd., Dayton, O.  
 PERSONNEL: C. A. Lange, Pres. & Gen. Mgr.; W. Frank, V. Pres.; E. S. Newlin, Secy. & Treas.; P. R. Baker, Sales Mgr.; H. Fischer, Pur. Agt.; J. Lange, Pers. Dir.; R. V. Huffman, Chief Engr.

**THE APEX TOOL CO., INC.,**

325 Cherry St., Bridgeport, Conn.  
 PERSONNEL: S. W. Swanson, Pres. & Treas.; S. Swanson, V. Pres.; D. Swanson, Secy.; A. W. Anderson, Pur. Agt.; J. Coppola, Chief Engr.

**S. APPEL & COMPANY, INC.,**

18 Fulton St., New York, N. Y.  
 PERSONNEL: G. I. Appel, Pres.; E. M. Bernstein, Secy.; H. Honeystein, Treas.

**APPLETON ELECTRIC CO.,**

1701-41 Wellington Ave., Chicago 13, Ill.  
 PERSONNEL: A. I. Appleton, Pres. & Treas.; Arthur I. Appleton, V. Pres.; M. J. Whitfield, V. Pres. & Sales Mgr.; J. V. Painter, Secy.; W. A. Robertson, Pur. Dir.; C. A. Bloom, Adv. Mgr.; W. A. Tornblom, Chief Engr.

**AQUA SYSTEMS INC.,**

385 Gerard Ave., New York, N. Y.  
 PERSONNEL: E. L. Greene, Pres.; W. J. Peter, V. Pres.-Engrg.; A. C. Kaestner, V. Pres.-Sales & Secy.; H. W. Ballantine, Treas.; H. B. Stewart, Pur. Agt.

**ARENS CONTROLS, INC.,**

2253 S. Halsted St., Chicago 8, Ill.  
 PERSONNEL: C. A. Arens, Pres. & Treas.; C. Norton, V. Pres. & Gen. Mgr.; W. Chase, Prod. Mgr.; P. Hooker, Sales Mgr. & Adv. Mgr.; E. J. Martineck, Pur. Dir.; H. A. Salmon, Pers. Dir.; G. Thorp, Chief Engr.

**THE ARO CO.,**

7301 Bessemer Ave., Cleveland 4, O.  
 PERSONNEL: H. E. Wise, Pres.; P. T. Hexter, V. Pres.; E. Sperry, Jr., Secy.; T. J. Esther, Pur. Dir.; S. P. Cramer, Adv. Mgr.

**ARMSTRONG BROS. TOOL CO.,**

317-357 N. Francisco Ave., Chicago, Ill.

**ARMSTRONG CORK CO., Lancaster, Pa.**

PERSONNEL: H. W. Prentiss, Jr., Pres.; F. L. Suter, V. Pres.; C. D. Armstrong, Secy.; K. Powlson, Treas.; J. J. Fitzpatrick, Gen. Mgr., Munitions Div.; F. E. Stevens, Gen. Mgr., Industrial Div.; W. B. Tucker, Sales Mgr., Industrial Div.; V. R. Despard, Jr., Mgr., Aircraft Dept.; R. A. Barton, Pur. Agt.; J. J. Evans, Jr., Pers. Dir.; W. D. Shilling, Pub. Dir.; C. F. Hawker, Chief Engr.

**THE ARMSTRONG MANUFACTURING CO., 303 Knowlton St., Bridgeport 8, Conn.**

PERSONNEL: B. I. Ashmun, Pres. & Gen. Mgr.; H. S. Ashmun, V. Pres., Sales Mgr. & Adv. Mgr.; F. S. Ashmun, Secy. & Treas.; H. E. Nelson, Prod. Mgr.; J. O'Shako, Pur. Dir. & Pers. Dir.; W. E. Allenby, Chief Engr.

**ARNOLT MOTOR CO.,**

Warsaw, Ind.  
 PERSONNEL: S. H. Arnolt, Pres., Treas. & Gen. Mgr.; E. T. White, V. Pres.; E. Razor, Secy.; C. L. McClellan, Prod. Mgr.; M. Myers, Sales Mgr. & Adv. Mgr.; H. O. Gerard, Pur. Dir.; F. H. Lightfoot, Pers. Dir.

**THE ARO EQUIPMENT CORP.,**

Bryan, O.  
 PERSONNEL: J. C. Markey, Pres.; J. P. Johnson, V. Pres.; J. E. Allen, Asst. to Pres.; E. G. Davies, Secy.; L. L. Hawk, Treas.; C. W. Ginter, Works Mgr.; C. H. Rice, Pur. Dir.; C. E. Ihrie, Adv. Mgr.

**ARROW BRASS FOUNDRY,**

733 New High St., Los Angeles, Calif.  
 PERSONNEL: D. E. Gilbert, Owner; E. F. Snowden, Supt. & Pur. Agt.

**ARROWHEAD RUBBER CO.,**

2244 E. 37th St., Vernon, Calif.  
 PERSONNEL: H. Franklin, Pres. & Gen. Mgr.; L. W. Winship, V. Pres.; D. Proud, Secy. & Treas.; A. Barth, Sales Mgr.; E. See, Pur. Agt.; H. Davis, Pers. Dir.; V. Nechke, Chief Engr.



# AIRCRAFT PRODUCTS

- Vacuum Pumps
- Propeller Hubs
- Oxygen Regulators
- Fuel Selector Valves
- Fuel Segregators
- Fuel Pumps
- Hydraulic Pumps
- Air-Vapor Eliminators

**The Aro Equipment Corp.**  
BRYAN, OHIO, U. S. A.

\*  
**Manufacturers of  
 PARACHUTES**

—  
**METAL STAMPINGS**

—  
**AIRCRAFT  
 SUB-ASSEMBLIES**

—  
**ORDNANCE**

—  
**HAYES MANUFACTURING  
 CORPORATION**

GRAND RAPIDS, MICHIGAN

*"Victory through Versatility"*

\*  
 —

---

## THE FLEX O TUBE COMPANY

DETROIT (16), MICHIGAN

—

Originators and manufacturers of all types of government specified aircraft flexible hose assemblies for oil, fuel, instrument, oxygen, super-charger and hydraulic actuation.

—

*Branch offices in Los Angeles, Fort Worth, Chicago,  
 New York and Toronto.*

---

**ART CHROME CO. OF AMERICA,**

141 Malden St., Boston, Mass.

PERSONNEL: E. Reiss, Pres. &amp; Gen. Mgr.; A. Reiss, V. Pres. &amp; Sales Mgr.

**ARTER GRINDING MACHINE CO.,**

15 Sagamore Rd., Worcester, Mass.

PERSONNEL: W. A. Arter, Pres.; H. Arter, V. Pres. &amp; Treas.; H. Tattersall, Secy. &amp; Pur. Agt.; A. B. O'Donnell, Sales Mgr.; W. F. Fraser, Chief Engr.

**ASSOCIATED FOUNDRIES & MANUFACTURERS, INC.,**

503-507 W. 56th St., New York, N. Y.

PERSONNEL: J. L. Hutchinson, Pres.; A. I. Berger, V. Pres. &amp; Chief Engr.

**ASSOCIATED RUBBER PRODUCTS CO.,**

1219 Springfield Ave., Irvington, N. J.

PERSONNEL: A. N. Shea, Pres. &amp; Sales Mgr.; J. A. Guthrie, Secy. &amp; Pur. Agt.; A. R. Berman, Gen. Mgr. &amp; Chief Engr.

**E. C. ATKINS & CO.,**

402 S. Illinois St., Indianapolis, Ind.

PERSONNEL: H. C. Atkins, Pres. &amp; Gen. Mgr.; E. C. Atkins, W. A. Atkins, V. Pres.; K. W. Atkins, V. Pres.-Sales; D. H. Potter, Secy. &amp; Treas.; G. W. Dunnington, R. F. Ellis, Sales Mgrs.; F. McCormick, Chief Engr.

**ATLANTIC INDIA RUBBER WORKS, INC.,**

1453 W. Van Buren St., Chicago, Ill.

PERSONNEL: C. O. Moore, Pres., Treas. &amp; Gen. Mgr.; R. V. Kline, V. Pres.; M. Moore, Secy.; W. Kauffman, Prod. Mgr.; S. R. Flett, Sales Mgr.; W. G. Linard, Pur. Dir. &amp; Adv. Mgr.

**ATLANTIC RAYON CORP.,** Industrial Fabrics Div., 350 Fifth Ave., New York 1, N. Y.**THE ATLANTIC REFINING CO.,**

260 S. Broad St., Philadelphia, Pa.

PERSONNEL: R. H. Colley, Pres.; W. D. Anderson, E. J. Henry, A. A. Garrabrant, V. Pres.; W. M. O'Connor, V. Pres. &amp; Secy.; W. C. Yeager, V. Pres. &amp; Sales Mgr.; P. Shuman, Treas.; J. S. Parks, Pur. Agt.; H. W. Jones, Pers. Dir.; R. Rollins, Pub. Dir.; L. M. Goldsmith, Chief Engr.

**ATLAS DROP FORGE CO.,**

209 W. Mt. Hope Ave., Lansing 2, Mich.

PERSONNEL: R. H. Scott, Pres. &amp; Gen. Mgr.; J. W. Hubbard, V. Pres.; L. G. Reutter, Secy.; E. L. Cooley, Treas.; E. H. Comstock, Prod. Mgr.; N. R. Buckingham, Sales Mgr., Adv. Mgr. &amp; Chief Engr.; A. O. Peterson, Pur. Dir.; F. H. Rowden, Pers. Dir.

**ATLAS PRESS CO.,** Kalamazoo, Mich.

PERSONNEL: J. H. Penniman, Pres. &amp; Gen. Mgr.; G. C. Nancarrow, V. Pres. &amp; Sales Mgr.; A. R. Eichelberg, Secy. &amp; Treas.; J. G. Collins, Pers. Dir.; H. J. Steele, Pur. Agt.; H. G. Dykhouse, Pub. Dir.; H. M. Musselman, Chief Engr.

**AUBURN SPARK PLUG CO., INC.,**

89 York St., Auburn, N. Y.

PERSONNEL: C. J. Nolin, Pres.; D. J. Mackenzie, Secy.; J. V. Moffet, Prod. Mgr.; C. I. Hinkle, Pur. Dir.; C. H. Rinehart, Chief Engr.

**AULT & WIBORG CORP.,**

75 Varick St., New York, N. Y.

PERSONNEL: J. R. Esposito, Pres.; J. G. Morris, Exec. V. Pres.; M. W. Frishkorn, V. Pres.; W. W. Wright, Secy.; H. A. Dunne, Treas.; W. H. Dornell, Sales Mgr., Aeronautical Div.; G. Welp, Pub. Dir.

**THE M. B. AUSTIN CO.,**

108-116 S. Desplaines St., Chicago, Ill.

PERSONNEL: M. B. Austin, Jr., Pres.; W. W. Kingsbury, V. Pres.; L. J. Peckham, Secy.; A. H. Friend, Treas. &amp; Sales Mgr.; R. E. Van Natta, Pur. Agt.; T. Heether, Chief Engr.

**AUTOMATIC ELECTRIC CO.,**

1033 W. Van Buren St., Chicago 7, Ill.

PERSONNEL: P. W. Conrad, Pres.; W. J. Caverly, V. Pres.; T. S. Gary, Sales Mgr.; W. E. A. Nottorf, Pur. Dir.; H. E. Clapham, Adv. Mgr.; K. W. Graybill, Chief Engr.

**AUTOMATIC ELECTRICAL DEVICES CO.,**

324 E. Third St., Cincinnati, O.

PERSONNEL: C. E. Ogden, Pres., Treas., Gen. Mgr., Sales Mgr. &amp; Pub. Dir.; H. F. Smith, V. Pres. &amp; Chief Engr.; A. H. Ewald, Secy.; W. H. Hirschire, Pur. Agt.

**AUTOMATIC TRANSPORTATION CO.,**

DIV. OF YALE &amp; TOWNE MFG. CO.,

101 W. 87th St., Chicago 20, Ill.

PERSONNEL: W. G. Carey, Jr., Pres.; C. Carey, V. Pres.; F. Dunning, Secy. &amp; Treas.; E. F. Twyman, Gen. Mgr.; P. K. Tremewen, Prod. Mgr.; R. L. Wolter, Sales Mgr.; R. H. Chapman, Pur. Dir.; R. M. Whitney, Pub. Dir. &amp; Adv. Mgr.; A. C. Elley, Chief Engr.

**THE AUTOMATIC VISE SALES CO.,**

2845 Sunset Pl., Los Angeles, Calif.

PERSONNEL: R. C. Andrus, Pres. &amp; Gen. Mgr.

**AUTOMOTIVE RUBBER CO.,**

8601 Epworth Blvd., Detroit, Mich.

PERSONNEL: R. L. Redmond, Pres.; T. G. Meulenberg, Gen. Mgr.; F. Kurt, Sales Mgr.; F. D. Wressell, Pur. Agt.

**AVERY ADHESIVES,**

451-453 E. Third St., Los Angeles, Calif.

PERSONNEL: R. S. Avery, Gen. Mgr.; M. McDougal, Sales Mgr.; R. W. Morris, Pur. Agt.; C. Stentz, Chief Engr.

**THE AVEY DRILLING MACHINE CO.,**

25 E. Third St., Covington, Ky.

PERSONNEL: L. B. Patterson, Pres.; D. A. Patterson, Secy.; G. K. McKee, Gen. Mgr.; J. E. Shriver, Sales Mgr.

**AVIQUIPO MANUFACTURING CORP.,**

25 Beaver St., New York 4, N. Y.

PERSONNEL: S. Niedelman, Pres.; M. B. Lambert, V. Pres.; M. M. Ranges, Secy.; F. J. Lazard, Treas.; E. Glasser, Asst. Secy.; J. Fisherman, Asst. Treas.

**AVONDALE CHEMICAL CO.,**

1030 N. Cleveland Ave., Chicago 10, Ill.

PERSONNEL: H. N. Limback, Pres. &amp; Chief Engr.; P. Kania, Prod. Mgr.

**AXELSON MANUFACTURING CO.,**

P. O. Box 98, Vernon Station, Los Angeles, Calif.

PERSONNEL: J. C. Axelson, Pres. &amp; Gen. Mgr.; D. F. Axelson, V. Pres. &amp; Pub. Dir.; L. E. Hogsett, Secy.; E. E. Kerfoot, Treas.; A. T. Jenkins, Pur. Agt.; C. D. Sills, Pers. Dir.; E. W. Ostrom, Chief Engr.

**EDWARD F. AYMOND CO.,**

3750 Urban Ave., Dallas, Tex.

PERSONNEL: E. F. Aymond, Owner.

**B****THE B G CORP.,**

136 W. 52nd St., New York 19, N. Y.

PERSONNEL: R. Goldsmith, Pres.



## A New Relay by AUTOMATIC ELECTRIC

This relay weighs less than two ounces, fills less than two cubic inches. Yet it operates up to twelve springs—regardless of vibration, humidity and extreme changes in temperature. Thousands like it are now in active service.

For data on this and other Automatic Electric relays, stepping switches, keys, microphones and other aircraft accessories, please write for our Catalog 4071-D. Address: Automatic Electric Sales Corporation, 1033 W. Van Buren St., Chicago 7, Ill.



Telephone, Communication and Signaling Products

## The Best Tools are made by Hand



**GRAHAM Hand Cut ROTARY FILES** are cut by craftsmen whose individual skill has been obtained from years of experience. This skill plus the best quality of high speed steel make **GRAHAM ROTARY FILES** tops in the field.

*Made in Rough, Coarse,  
Fine or Smooth Finish*

to solve your individual problem, and suitable for the most delicate or heaviest work.

Write Dept. A. Y. for  
Catalog & Price List  
**GRAHAM ROTARY FILE  
& TOOL CO.**

387 Fourth Avenue  
New York 16, N. Y.



**S. S. WHITE  
FLEXIBLE  
SHAFTS  
FOR Aircraft**

Combinations of Flexible Shafts, Flexible Casings and Fittings for all Aircraft uses including the following:

**REMOTE CONTROL—**  
for Radio Transmitters, Receivers, Loops, Reels, Tabs, Cowl Flaps, Bank Indicators, Bomb Sights, Heating Registers, Air Conditioning and all other equipment requiring remote control.

**POWER DRIVES—**  
for Tachometers, Fuel Pumps, Variable Pitch Propeller Governors, Ammunition Rounds Counters, Windshield Wipers and all other driven apparatus.

**FULL ENGINEERING COOPERATION**

**PIONEER  
& LEADING  
MAKER OF  
FLEXIBLE  
SHAFTS...**

## S. S. WHITE

The S. S. White Dental Mfg. Co.

### INDUSTRIAL DIVISION

Department Y, 10 East 40th St., New York 16, N. Y.



- B. H. AIRCRAFT CO.**, 27-01 Bridge Plaza  
North, Long Island City, N. Y.
- BABBITT INDUSTRIAL SPECIALTIES CO.**,  
630 Fifth Ave., New York 20, N. Y.  
PERSONNEL: T. T. Toole, Pres.; M. C. Brock,  
Prod. Mgr.; L. G. McHugh, Sales Mgr.
- SEMON BACHE & CO.**,  
636 Greenwich St., New York, N. Y.  
PERSONNEL: J. Dreyfuss, Pres.; D. Hirsch,  
V. Pres.; R. M. Dreyfuss, Secy.; E. O. Salman,  
Treas.; M. Mariani, Gen. Mgr.; B. Newton,  
Sales Mgr. & Pub. Dir.; M. S. Goodman, Pur.  
Agt.; H. DeiTosto, Pers. Dir.; E. Avalone,  
Chief Engr.
- BACKSTAY WELT CO.**,  
Union City, Ind.  
PERSONNEL: R. C. Schemmel, Pres.; G. G.  
Barr, V. Pres., Gen. Mgr. & Pur. Dir.; P. J.  
Keck, Secy. & Treas.; H. P. Welch, Prod. Mgr.;  
A. C. Pogue, Sales Mgr.; G. H. Huffer, Chief  
Engr.
- BACON VULCANIZER MFG. CO.**,  
1267-67th St., Oakland, Calif.  
PERSONNEL: T. P. Bacon, Sr., Pres. & Gen.  
Mgr.; T. P. Bacon, Jr., V. Pres. & Chief Engr.;  
P. P. Marion, Secy., Treas. & Sales Mgr., A.  
Passero, Pur. Agt.
- THE BAIRD MACHINE CO.**,  
Stratford 9, Conn.  
PERSONNEL: L. A. Warner, Pres., Treas. & Gen.  
Mgr.; B. C. Warner, V. Pres. & Prod. Mgr.;  
A. J. Lewis, Sr., Secy. & Chief Engr.; A. Pott,  
Sales Mgr., Pub. Dir., & Adv. Mgr.; J. E.  
Reynolds, Pers. Dir. & Pur. Dir.
- BAKER & CO., INC.**,  
113 Astor St., Newark 5, N. J.  
PERSONNEL: C. Engelhard, Pres., Treas. & Gen.  
Mgr.; A. M. Williams, V. Pres.
- BAKER INDUSTRIAL TRUCK DIV. THE  
BAKER-RAULANG CO.**, 2149 West  
25th St., Cleveland, O.  
PERSONNEL: E. J. Bartlett, Pres. & Gen. Mgr.;  
E. J. Stahl, V. Pres.; J. W. Moran, Secy. &  
Treas.; D. L. Darnell, Sales Mgr.; E. W.  
Sankey, Pur. Agt.; W. F. Parsons, Pers. Dir.;  
M. W. McMillan, Pub. Dir.; B. F. Stoner,  
Chief Engr.
- BAKER-SPIEGEL CO.**,  
405 Boulevard Bldg., Detroit 2, Mich.  
PERSONNEL: H. W. Spiegel, Gen. Mgr.; H. K.  
Baker, Chief Engr.
- BAKER STEEL & TUBE CO.**,  
955 S. Alameda St., Los Angeles, Calif.  
PERSONNEL: R. Mulholland, Pres.; M. J.  
Baker, V. Pres.; W. F. Fahs, Secy. & Treas.; J.  
P. Boore, Gen. Mgr. & Sales Mgr.
- BAKEWELL MANUFACTURING CO.**,  
2023 Santa Fe Ave., Los Angeles, Calif.  
PERSONNEL: H. F. Bakewell, Owner & Gen.  
Mgr.; N. C. Nourse, Sales Mgr.; J. Kuhn, Pur.  
Agt.; L. McKenzie, Pers. Dir.; R. S. Arnold,  
Pub. Dir.; J. Goodwin, Chief Engr.
- BALDOR ELECTRIC CO.**,  
4351-69 Duncan Ave., St. Louis, Mo.  
PERSONNEL: E. Ballman, Pres., Gen. Mgr. &  
Chief Engr.; F. B. Rogers, V. Pres.; O. A.  
Baumann, Secy.; E. Doerr, Treas.; E. W.  
Bruce, Sales Mgr.; E. Reinagel, Pur. Agt.;  
O. A. Life, Pub. Dir.
- BALDWIN DUCKWORTH DIV. OF CHAIN  
BELT CO.**, 333 Plainfield St., Spring-  
field 2, Mass.  
PERSONNEL: G. D. Gilbert, Secy. & Gen. Mgr.;  
B. H. MacLeod, Sales Mgr.; E. J. Greene, Pur.  
Dir.; S. W. Johns, Adv. Mgr.
- BALTIC METAL PRODUCTS CO.**,  
366 Butler St., Brooklyn, N. Y.  
PERSONNEL: S. L. Schlanger, Pres. & Chief  
Engr.; L. Levine, Secy.
- BANTAM BEARINGS CORP.**,  
South Bend, Ind.  
PERSONNEL: F. W. Deming, Pres.; R. B.  
Nichols, V. Pres. & Gen. Mgr.; W. T. Bell,  
Secy. & Treas.; J. F. Oehlhoffen, Sales Mgr.;  
E. A. Olson, Pur. Agt.; J. Barber, Pers. Dir.;  
S. R. Thomas, Chief Engr.
- BARBER-COLMAN CO.**, Rockford, Ill.  
PERSONNEL: H. A. Severson, Pres.; J. G. Jones,  
Secy.; O. O. Smith, Treas.; E. D. Parker, Gen.  
Mgr.; C. J. Braatz, Sales Mgr.; H. W. Bails,  
Pur. Agt.; A. M. Monks, Pers. Dir.; H. E.  
Shuggars, Pub. Dir.; T. K. Greenlee, Chief  
Engr.
- BARBOUR STOCKWELL CO.**,  
205 Broadway, Cambridge, Mass.  
PERSONNEL: E. F. Stockwell, Pres.
- BARDCO MANUFACTURING & SALES CO.**,  
2450 E. 23rd St., Los Angeles, Calif.  
PERSONNEL: F. Jervis, Pres.; L. Jervis, V.  
Pres.; E. F. Brown, Gen. Mgr.; W. J. Ashton,  
Pur. Agt.; E. C. Ball, Pers. Dir.; J. Netherly,  
Production Mgr.
- BARDWELL & McALISTER, INC.**,  
P. O. Box 1310, Hollywood, Calif.  
PERSONNEL: J. G. McAlister, Pres.; C. Bard-  
well, V. Pres. & Secy.; K. D. Clardy, Treas.;  
L. W. Olson, Prod. Mgr.; P. Waas, Pur. Dir.;  
H. B. Chipman, Pers. Dir.; I. Brennan, Adv.  
Mgr.; J. A. Romoli, Chief Engr.
- W. F. & JOHN BARNES CO.**,  
301-311 S. Water St., Rockford, Ill.  
PERSONNEL: E. V. Eastman, Pub. Dir. & Adv.  
Mgr.
- BARNES DRILL CO.**,  
814 Chestnut St., Rockford, Ill.  
PERSONNEL: J. E. Andrews, Ch.; A. M. John-  
son, Pres.; W. M. Fairbairn, V. Pres. & Works  
Mgr.; R. M. Andrews, V. Pres. & Foreign Mgr.;  
A. G. Block, Secy. & Treas.; F. A. Swanson,  
Domestic Sales Mgr.; G. E. Andrews, Pur. Dir.;  
H. J. Caldwell, Chief Engr.
- BARNES-GIBSON-RAYMOND DIV. OF AS-  
SOCIATED SPRING CORP.**, 6400  
Miller Ave., Detroit, Mich.  
PERSONNEL: L. D. Adams, V. Pres. & Gen.  
Mgr.; W. J. Black, Sales Mgr.; C. W. Naas,  
Factory Mgr.; L. E. Hilts, Pur. Agt.; F. P.  
Zimmerli, Chief Engr.
- BARRETT-CRAVENS CO.**,  
3255 W. 30th St., Chicago 23, Ill.  
PERSONNEL: A. M. Barrett, Pres. & Treas.;  
E. J. Heimer, V. Pres., Gen. Mgr. & Sales Mgr.;  
O. M. Lund, Secy. & Chief Engr.; H. T. Mun-  
ton, Prod. Mgr.; G. J. Collinet, Pur. Dir.;  
H. W. Carr, Pers. Dir.; W. J. Kennedy, Pub.  
Dir. & Adv. Mgr.
- BARRETT EQUIPMENT CO.**,  
Cass Ave. at 21st St., St. Louis, Mo.  
PERSONNEL: H. B. Barrett, Pres.; J. W. Craw-  
ford, V. Pres., Gen. Mgr., Sales Mgr., Pub.  
Dir. & Adv. Mgr.; F. W. Heppe, V. Pres. &  
Treas.; G. S. Garstang, Secy.; S. E. Obert,  
Prod. Mgr.; J. R. Vallentine, Pur. Dir.; J.  
Chura, Pers. Dir.; A. E. Terpening, Chief Engr.
- THE BARRETT DIV., ALLIED CHEMICAL  
& DYE CORP.**, 40 Rector St., New  
York, N. Y.

**B-H**

**MANUFACTURERS  
OF SHEET METAL AND  
TUBULAR ACCESSORIES**



- Cowls
- Oars & Pumps
- Collector Rings
- Tubular Parts
- Sheet Metal Stampings
- Manifolds
- Engine Mounts
- Aluminum Tanks
- Sheet Metal Fabrication

**CONTRACTORS TO ALL LEADING  
ENGINE AND PROPELLER MANUFACTURERS**

**B. H. AIRCRAFT CO., Inc.**  
LONG ISLAND CITY 1, NEW YORK

**BARTLETT HAYWARD DIV. KOPPERS CO.,**  
200 Scott St., Baltimore, Md.  
PERSONNEL: W. F. Perkins, V. Pres.; J. E. Tellman, Secy. & Treas.; E. R. Hall, Gen. Mgr.; S. H. Pedan, Sales Mgr.; J. E. Aldridge, Pur. Agt.; W. Ortman, Pers. Dir.; P. F. Hackethal, Chief Engr.

**REX BASSETT, INC.,**  
500 S. E. Second St., Ft. Lauderdale, Fla.  
PERSONNEL: R. E. Bassett, Jr., Pres. & Treas.; M. E. Bassett, V. Pres.; W. B. Giles, Secy.; R. E. Bassett, Sr., Gen. Mgr., Sales Mgr. & Pur. Agt.; J. Street, Pers. Dir.; E. Jones, Chief Engr.

**THE BASSICK CO.,**  
Bridgeport 2, Conn.  
PERSONNEL: W. A. Rose, Pres.; W. F. Herold, V. Pres.; W. G. Reycroft, V. Pres. & Sales Mgr.; J. T. Foerth, Treas.; W. Seward, Pur. Dir.; R. Rice, Pers. Dir.; R. D. Mount, Adv. Mgr.

**BASTIAN BROS. CO.,**  
1600 Clinton Ave., N. Rochester, N. Y.  
PERSONNEL: W. J. Wolf, Pres. & Gen. Mgr.; F. J. Brown, V. Pres.; J. H. Mahoney, Secy.; F. J. Temmerman, Treas.; L. W. Shanley, Pur. Agt.

**BAUER & BLACK, DIV. OF THE KENDALL CO.,** 2500 S. Dearborn St., Chicago, Ill.

**BAUSCH & LOMB OPTICAL CO.,**  
St. Paul St., Rochester, N. Y.  
PERSONNEL: H. Eisenhart, Pres. & Gen. Mgr.; C. S. Hallauer, V. Pres. & Sales Mgr.; W. W. McQuilkin, Secy.; J. F. Taylor, Treas.; J. E. Hansen, Pur. Agt.; R. B. Welch, Pers. Dir.; M. C. Williamson, Pub. Dir.; C. L. Bausch, Chief Engr.

**BAY MFG. DIV., THE ELECTRIC AUTO-LITE CO.,** Bay City, Mich.  
PERSONNEL: C. M. Adams, V. Pres. & Gen. Mgr.; J. P. Kelso, Sales Mgr.; B. D. Kimerer, Pur. Agt.; L. M. Reynolds, Pers. Dir.

**BEARIUM METALS CORP.,**  
268 State St., Rochester 4, N. Y.  
PERSONNEL: E. P. Langworthy, Pres.; G. P. Palma, V. Pres.

**THE BEATON & CORBIN MFG. CO.,**  
Southington, Conn.  
PERSONNEL: A. R. Wells, Pres.; C. W. Rush, V. Pres. & Pur. Agt.; A. E. Ralston, Secy.; H. B. Armstrong, Treas. & Gen. Mgr.

**BECKETT ELECTRIC CO., INC.,**  
1101-7 McKinney Ave., Dallas, Tex.  
PERSONNEL: T. G. Beckett, Pres.; T. G. Beckett, Jr., V. Pres.; E. T. Summers, Treas. & Sales Mgr.

**BELDEN MANUFACTURING CO.,**  
4647 W. Van Buren St., Chicago, Ill.  
PERSONNEL: W. Jacobs, Pres.; C. S. Craigmile, Exec. V. Pres.; H. W. Clough, V. Pres.; A. Beutler, Secy.; A. L. Wanner, Treas.; H. A. Neil, Sales Mgr.; W. A. Sandy, Pur. Agt.; S. F. Kiss, Pers. Dir.; B. Rogers, Pub. Dir.; H. H. Wermine, Chief Engr.

**BELDING HEMINWAY CO.,**  
119 W. 40th St., New York, N. Y.  
PERSONNEL: J. P. T. Armstrong, Pres.; F. D. Levi, V. Pres.; F. L. Johnson, V. Pres. & Sales Mgr.; H. A. Johnson, V. Pres. & Chief Engr.; C. G. Heinrich, Secy. & Treas.

**THE BELL CO., INC.,**  
411 N. Wolcott Ave., Chicago 22, Ill.  
PERSONNEL: J. M. Bell, Pres.; C. E. Alderdice, Jr., V. Pres., Gen. Mgr., Sales Mgr. & Chief Engr.; C. J. Bell, Secy. & Treas.; R. L. Hicks, Prod. Mgr. & Chief Engr.; G. E. Kugelmann, Pur. Dir.

**BELL & HOWELL CO.,**  
1801 Larchmont Ave., Chicago 13, Ill.  
PERSONNEL: J. H. McNabb, Pres. & Treas.; A. S. Howell, H. W. Remerscheid, F. M. Hall, V. Pres.; J. H. Booth, V. Pres., Sales Mgr. & Adv. Mgr.; C. V. Clark, Secy.; E. G. Mayer, Prod. Mgr.; C. Schreyer, Pur. Dir.; E. R. Ellington, Pers. Dir.; M. H. Ostrom, Pub. Dir.; C. E. Phillimore, Chief Engr.

**BELLANCA AIRCRAFT CORP.,**  
New Castle, Del.  
PERSONNEL: N. F. Vanderlipp, Pres.; L. C. Milburn, V. Pres. & Gen. Mgr.; A. F. Haiduck, V. Pres.; H. L. Thompson, Secy., Sales Mgr. & Adv. Mgr.; S. S. Arsht, Treas.; R. F. Wright, Pur. Dir.; I. H. Brinton, Pers. Dir.; W. P. Searfoss, Pub. Dir.

**BELLOIL PAINT PRODUCTS CO.,**  
547 W. Lake St., Chicago, Ill.  
PERSONNEL: A. M. Craig, Secy.; J. O. Clark, Sales Mgr.; P. N. Belleisle, Chief Engr.

**BELMONT RADIO CORP.,**  
5921 W. Dickens Ave., Chicago 39, Ill.  
PERSONNEL: P. S. Billings, Pres.; H. C. Mattes, V. Pres., Treas. & Gen. Mgr.; J. Robertson, Secy.; L. Boji, Prod. Mgr.; C. M. Hofman, Sales Mgr.; G. E. Neuhauser, Pur. Dir.; R. Schwertfeger, Pers. Dir.; S. Freshman, Pub. Dir. & Adv. Mgr.; W. L. Dunn, Chief Engr.

**BENDIX AVIATION CORP.,**  
1104 Fisher Bldg., Detroit, Mich.  
PERSONNEL: E. R. Breech, Pres.

**BENDIX AVIATION CORP., PACIFIC DIV.,**  
11600 Sherman Way, N. Hollywood, Calif.

PERSONNEL: P. Nicholls, Gen. Mgr.; M. M. Burns, Asst. Gen. Mgr.; R. C. Fuller, Sales Mgr.; J. M. Hannum, Pur. Dir.; A. F. Malmquist, Pers. Dir.; J. B. Shaw, Adv. Mgr.

**BENDIX AVIATION CORP., PHILADELPHIA DIV.,** 4700 Wissahickon Ave., Philadelphia 44, Pa.

PERSONNEL: T. W. Tinkam, Gen. Mgr.; C. H. DeGraw, Prod. Mgr.; H. F. McEnness, Sales Mgr.; L. Leib, Pur. Dir.; R. G. Kremer, Pers. Dir.; H. C. Pierce, Pub. Dir. & Adv. Mgr.; H. Loen, Chief Engr.

**BENDIX PRODUCTS DIV. OF BENDIX AVIATION CORP.,** South Bend, Ind.

PERSONNEL: M. P. Ferguson, Div. Vice Pres.; G. E. Stoll, Asst. Gen. Mgr.; G. Lyman, Prod. Mgr.; F. B. Willis, Sales Mgr.; C. E. Budd, Pur. Dir.; M. E. Stone, Pers. Dir.; S. V. Harding, Adv. Mgr.; K. M. Wise, Chief Engr.; Carl Byoir & Assoc., Pub. Dir.

**BENDIX RADIO DIV., BENDIX AVIATION CORP.,** Towson 4, Md.

PERSONNEL: H. Benet, Gen. Mgr.; E. K. Poster, Prod. Mgr.; J. W. Hammond, Sales Mgr.; G. M. Hafner, Pur. Dir.; J. H. Kahlert, Pers. Dir.; W. P. Hilliard, Dir. Sales & Engrg.; W. L. Webb, Chief Engr.

**THE BENNETT METAL TREATING CO.,**  
1045 New Britain Ave., Elmwood, Conn.  
PERSONNEL: A. J. German, Pres.; J. P. German, Secy.; A. L. Davis, Treas.

**BENRUS WATCH CO.,**  
200 Hudson St., New York, N. Y.  
PERSONNEL: B. Lazrus, O. M. Lazrus, S. R. Lazrus, Partners.

# FLIGHT INTO THE FUTURE



with  
**THE BENDIX "INVISIBLE CREW"**

**F**ROM starting, ignition and carburetion to the ultimate in automatic pilots, the Bendix "Invisible Crew" encompasses the whole range of aircraft instrumentation, accessories and controls. The goal of this far-reaching engineering is to eliminate every possible factor of human effort and human error. And in the steady approach toward that goal, Bendix research is truly soaring years ahead of these times . . . into a wondrous air-borne future.



SOME FAMOUS MEMBERS OF "THE INVISIBLE CREW"—**PIONEER\*** Flight Instruments. **BENDIX\*** Radio, Avigation, Detection, Communication Systems. **STROMBERG\*** Aircraft Injection Carburetors. **ECLIPSE\*** AVIATION Starters, Auxiliaries. **ECLIPSE MACHINE** Starter Drives. **SCINTILLA\*** Aircraft Ignition. **BENDIX PRODUCTS** Stromberg Automotive Carburetors, Brakes, Landing Gear. **FRIEZ\*** Weather Instruments. **ZENITH\*** Carburetors. **BENDIX\*** Marine Controls.

\*TRADE MARKS OF BENDIX AVIATION CORPORATION OR SUBSIDIARIES

**THE BENSON MANUFACTURING CO.,**  
3001-15 E. 18th St., Kansas City, Mo.  
PERSONNEL: A. J. Benson, Pres.; E. H. Benson,  
V. Pres.; E. L. Benson, Secy.; E. A. Benson,  
Treas.; R. F. Bullock, Pur. Agt.; L. C. Camp-  
bell, Chief Engr.

**THE BENWOOD LINZE CO.,**  
1815 Locust St., St. Louis, Mo.  
PERSONNEL: H. J. Wrape, Pres.; C. E. Peters,  
V. Pres.; I. W. Veigel, Treas.; F. A. Waelter-  
man, Rectifier Engr.; W. A. Butler, Special  
Sales Rep.; A. R. Kieffer, Jr., Pur. Agt.

**BERGER BROTHERS CO.,**  
229-237 Arch St., Philadelphia 6, Pa.  
PERSONNEL: H. E. Usinger, Pres.; H. B. Felt-  
man, Secy.; R. H. Hoffman, Treas.; R. S.  
Brown, Sales Mgr.; C. C. Beez, Pur. Dir.

**BERGER MANUFACTURING DIV., RE-  
PUBLIC STEEL CORP.,** 1038 Beiden  
Ave., N. E., Canton 5, O.  
PERSONNEL: R. W. Helms, Sales Mgr.; K. R.  
Foltz, Pur. Dir.; N. W. Sutmaier, Adv. Mgr.;  
E. T. Causer, Works Mgr.

**BERRY BROTHERS, INC.,**  
211 Leib St., Detroit 7, Mich.  
PERSONNEL: A. Kiernan, Pres.; E. H. Dunn,  
Treas.; C. E. Spooner, Aviation Sales Mgr.;  
H. Dedenback, Pur. Dir.; J. D. Greene, Adv.  
Mgr.; G. C. Smith, Chief Chemist.

**BERTEA PRODUCTS,**  
1450 N. Lake Ave., Pasadena, Calif.  
PERSONNEL: Alex Bertea, Gen. Mgr. & Chief  
Engr.; C. Sorenson, Sales Mgr.; Ann Bertea,  
Pur. Agt.; H. G. Williams, Pers. Dir.

**JACK BEST MFG., CO.,**  
2128 S. Los Angeles St., Los Angeles,  
Calif.  
PERSONNEL: G. J. Anderson, Gen. Mgr.

**BETHEHEM STEEL CO.,** Bethlehem, Pa.

**THE BILLINGS & SPENCER CO.,**  
One Laurel St., Hartford 6, Conn.  
PERSONNEL: W. A. Purtell, Pres. & Gen. Mgr.;  
R. J. Ahern, Exec. V. Pres. & Prod. Mgr.;  
H. E. Oberg, V. Pres.; W. D. Endres, V. Pres.  
& Sales Mgr.; E. F. Cummings, Secy. & Treas.;  
W. Blackburn, Pur. Dir.; R. H. Young, Adv.  
Mgr.; M. Kincaid, Chief Engr.

**BLACK BEAR CO., INC.,**  
620 Fifth Ave., New York 20, N. Y.  
PERSONNEL: R. A. Schleicher, Pres.; F. G.  
Kaemer, V. Pres.; M. E. Bingham, Secy.; F. G.  
Schleicher, Treas.; W. M. Grampp, Gen. Mgr.;  
S. S. Jamieson, Prod. Mgr.; A. de Goll, Sales  
Mgr.; R. H. Ellis, Pur. Dir.; W. Richardson,  
Pers. Dir.; J. R. Boyd, Pub. Dir.; T. Towles,  
Chief Engr.

**THE BLACK & DECKER MFG. CO.,**  
Towson 4, Md.  
PERSONNEL: S. D. Black, Pres.; A. G. Decker,  
V. Pres. & Gen. Mgr.; C. A. Sacra, Secy.; F. J.  
Nagell, Treas.; A. G. Decker, Jr., Prod. Mgr.;  
R. D. Black, Sales Mgr.; C. B. Mann, Pur. Dir.;  
H. T. Douglas, Pers. Dir.; J. F. Apsey, Jr., Adv.  
Mgr.; G. C. Wilhide, Chief Engr.

**BLACKER ENGINEERING CORP.,**  
136 Liberty St., New York, N. Y.  
PERSONNEL: E. B. Cooke, Pres. & Gen. Mgr.;  
L. B. Dexter, V. Pres.; W. F. Shorter, Secy.;  
C. D. Cooke, Treas.

**BLACKHAWK MFG. CO.,**  
5325 W. Rogers, Milwaukee, Wisc.  
PERSONNEL: H. P. Brumder, Pres.; J. C.  
Merker, V. Pres. & Gen. Mgr.; G. H. Goehrig,  
V. Pres. & Sales Mgr.; E. M. Pfauter, V. Pres.  
& Chief Engr.; L. E. Bertane, Treas.; G.  
Cremer, Pur. Agt.; P. J. Spielmann, Pers. Dir.;  
B. E. Hotvedt, Pub. Dir.

**BLACKMER PUMP CO.,**  
Grand Rapids 9, Mich.  
PERSONNEL: N. J. Harkness, Exec. V. Pres. &  
Gen. Mgr.; G. Norcross, Secy.; J. Vande Bunte,  
Treas.; L. N. Pangborn, Prod. Mgr.; J. B.  
Trotman, Sales Mgr. & Adv. Mgr.; V. Rhodes,  
Pur. Dir.; E. W. Chapman, Chief Engr.

**BLANCHARD BROS. & LANE,**  
408 Frelinghuysen Ave., Newark, N. J.  
PERSONNEL: J. H. Gay, Pres.; W. G. Ressler,  
V. Pres. & Sales Mgr.; H. G. Crawford, Secy.;  
S. B. Gay, Treas.; K. W. Koeinger, Pur. Agt.

**BLILEY ELECTRIC CO.,**  
Union Station, Erie, Pa.  
PERSONNEL: F. D. Bliley, Pres. & Gen. Mgr.;  
C. C. Collman, V. Pres.; Q. Horsman, Treas.;  
G. E. Wright, Sales Mgr.; J. Reigelman, Pur.  
Agt.; A. Pero, Pers. Dir.; J. M. Wolfskill, Chief  
Engr.

**E. W. BLISS CO.,**  
53rd St. & Second Ave., Brooklyn, N. Y.  
PERSONNEL: H. H. Pinney, Pres.; H. U.  
Herrick, V. Pres.; E. S. McClary, Secy. &  
Treas.; R. Biggane, Sales Mgr.; F. B. Smith,  
Pur. Agt.; H. F. Smith, Pers. Dir.; M. Stumm,  
Adv. Mgr.; I. Patrick, Chief Engr.

**SIDNEY BLUMENTHAL & CO., INC.,**  
1 Park Ave., New York, N. Y.  
PERSONNEL: H. H. Schell, Pres.; J. J. Hoyne,  
V. Pres.; J. Fenske, Secy.; G. Beisheim, Treas.;  
W. P. Mimmagh, Sales Mgr.; E. S. Cobb, Pur.  
Agt.; E. S. Evans, Pers. Dir.

**BODINE ELECTRIC CO.,**  
2254 W. Ohio St., Chicago, Ill.  
PERSONNEL: C. D. Bodine, Pres.; E. W. Larson,  
V. Pres. & Pur. Agt.; P. J. Bodine, Secy. &  
Treas.; W. M. Yogerst, Sales Mgr.; J. W.  
Towle, Pers. Dir.; C. A. Rall, Chief Engr.

**THE W. W. BOES CO.,**  
3001 Salem Ave., Dayton 1, O.  
PERSONNEL: W. W. Boes, Pres.; H. E. Ruble,  
Prod. Mgr.; W. E. Harbottle, Jr., Sales Dept.;  
C. G. Harvey, Pur. Dir.; R. D. Ebert, Pers.  
Dir.; B. M. Shipley, Chief Engr.; J. R. Wall,  
Asst. Engr.

**BOICE-CRANE CO.,**  
930 W. Central Ave., Toledo 6, O.  
PERSONNEL: W. B. Boice, Gen. Mgr.; J. R.  
Rettie, Prod. Mgr.; M. H. Bucher, Sales Mgr.  
& Adv. Mgr.; J. H. Luken, Pur. Dir.

**BOKELMAN CO., INC.,**  
45 E. 53rd St., New York, N. Y.  
PERSONNEL: L. F. Timmerman, Pres.; H. T.  
Holland, V. Pres. & Pur. Dir.; F. Keehn, Secy.;  
H. E. Dunn, Treas.; R. Boetticher, Gen. Mgr.

**BOLTON MANUFACTURING CORP.,**  
692 Campbell Ave., West Haven, Conn.  
PERSONNEL: W. H. Carney, Pres.; K. A. Kins-  
man, V. Pres. & Sales Mgr.; H. S. Elder, Secy.  
& Treas.; C. A. Brown, Factory Mgr.; W. Riehl,  
Pur. Dir.; A. Hutton, Chief Engr.; R. J.  
Clifford, Chief Inspector.

**BONDED SCALE CO.,**  
2176 S. Third St., Columbus 7, O.  
PERSONNEL: A. Gluck, Pres., Treas. & Gen.  
Mgr.; M. Roth, V. Pres.; F. Gluck, Secy.



**Dependability Proven in Flight**

*Eclipse* AVIATION ACCESSORIES

- ★ ENGINE STARTING SYSTEMS
- ★ POWER SUPPLY SYSTEMS
- ★ SUCTION & AIR PRESSURE SYSTEMS
- ★ ENGINE & PROPELLER CONTROL SYSTEMS
- ★ ICE ELIMINATION SYSTEMS
- ★ SERVO CONTROL SYSTEMS
- ★ HYDRAULIC EQUIPMENT
- ★ MISCELLANEOUS ELECTRICAL & MECHANICAL COMPONENTS



**ECLIPSE-PIONEER DIVISION**

**BENDIX AVIATION CORPORATION, Teterboro, N. J.**



**BONNEY FORGE & TOOLWORKS,**

Allentown, Pa.

PERSONNEL: F. S. Durham, Pres. & Gen. Mgr.; J. E. Durham, Jr., V. Pres.; A. J. Male, Secy., Treas. & Sales Mgr.; W. F. Herbst, Jr., Pur. Agt.; S. R. Robinson, Pub. Dir.

**THE BOOTH FELT CO.,**

463 19th St., Brooklyn, N. Y.

PERSONNEL: E. W. Booth, Owner, Treas., Gen. Mgr. & Pur. Agt.; L. D. Croninger, V. Pres.; J. H. Murray, Secy.; R. S. Stevens, Sales Mgr.

**BOOTS AIRCRAFT NUT CORP.,**

New Canaan, Conn.

PERSONNEL: N. J. Boots, Pres.; R. W. Luce, V. Pres.-Engrg.; O. H. Schell, Secy.; C. A. Milton, Treas. & Pur. Dir.; R. W. Johnson, V. Pres. & Gen. Mgr.; R. F. Hibbert, Sales Mgr.; D. H. McComas, Pers. Dir.; W. C. Wootton, Chief Engr.

**BOSTITCH, INC., E. Greenwich, R. I.**

PERSONNEL: J. D. A. Whalen, Pres., Treas. & Gen. Mgr.; F. I. Brown, V. Pres. & Sales Mgr.; E. C. Mowry, Secy.; J. E. Scully, Pur. Agt.; S. L. Smith, Pub. Dir.

**THE BOSTON AUTO GAGE CO.,**

Pittsfield, Mass.

PERSONNEL: T. C. Nelson, Pres. & Sales Mgr.; H. MacKelvic, V. Pres. & Chief Engr.; M. M. Best, Secy.; H. J. Martin, Treas.; L. W. Foote, Prod. Mgr.; C. H. Hines, Pur. Dir.

**BOSTON INSULATED WIRE & CABLE CO.,**

75 Bay St., Dorchester, Mass.

PERSONNEL: H. B. Burley, Pres. & Treas.; J. C. Burley, V. Pres., Sales Mgr. & Chief Engr.; M. G. Fitzgerald, Secy.; H. B. Burley, Jr., Prod. Mgr.

**BOUND BROOK OIL-LESS BEARING CO.,**

Bound Brook, N. J.

PERSONNEL: W. F. Jennings, Pres. & Treas.; H. O. Johnson, V. Pres., Secy. & Sales Mgr.; D. H. Carhart, Pur. Agt.; C. Claus, Chief Engr.

**BOWER ROLLER BEARING CO.,**

3040 Hart Ave., Detroit, Mich.

PERSONNEL: S. A. Strickland, Pres.; W. S. Bennett, V. Pres. & Sales Mgr.; T. C. Dye, Secy. & Treas.; G. F. Johnson, Gen. Mgr.; E. M. Pratt, Pur. Agt.; M. J. Olson, Pers. Dir.; E. Wooler, Chief Engr.

**THE BOWLING GREEN RUBBER CO.,**

1209 Prospect St. at N. Y. Central, Toledo 6, O.

PERSONNEL: S. Roberts, Pres.; R. Roberts, V. Pres., Secy. & Gen. Mgr.; I. F. Zarobsky, Chief Engr.

**S. F. BOWSER & CO., INC.,**

1302 E. Creighton Ave., Ft. Wayne, Ind.

PERSONNEL: R. H. Damon, Pres.; E. D. Eggimann, V. Pres.; J. F. Bartels, Secy. & Treas.; E. C. Marsh, Sales Mgr.; E. A. Steinhauer, Pur. Agt.; H. J. Slack, Pub. Dir.; C. P. Griffith, Chief Engr.

**BRASCO MANUFACTURING CO.,**

Harvey, Ill.

PERSONNEL: L. Barton, Pres.; M. J. Rosenfeld, V. Pres., Treas. & Gen. Mgr.; C. B. Hess, Secy.; A. W. Sorenson, Pur. Agt.; E. Roach, Pers. Dir.; J. J. Arnsfield, Pub. Dir.; J. J. Bosshard, Chief Engr.

**BREEZE CORPORATIONS, INC.,**

24 S. Sixth St., Newark 7, N. J.

PERSONNEL: J. T. Mascuch, Pres.; J. F. Lucas, V. Pres.; F. G. Shupp, Treas.; G. Braumueller, Pur. Dir.; J. F. Keating, Pers. Dir.; K. G. Strunk, Chief Engr.

**BREUER ELECTRIC MFG. CO.,**

5100 N. Ravenswood Ave., Chicago 40, Ill.

PERSONNEL: B. R. Breuer, Pres.; R. G. Breuer, Secy.; J. P. Jason, Prod. Mgr.; C. A. Bremmer, Sales Mgr. & Pub. Dir.; L. C. Miles, Pur. Dir.; J. M. Haggard, Adv. Mgr.

**THE BREWER-TITCHENER CORP.,**

111 Port Watson St., Cortland, N. Y.

PERSONNEL: E. A. Brewer, Pres. & Treas.; D. A. Brewer, V. Pres.; J. Greene, Secy.; M. E. Maxon, Sales Mgr.; A. W. Hoffman, Pur. Dir.; W. A. Bruce, Pub. Dir. & Adv. Mgr.

**BREWSTER AERONAUTICAL CORP.,**

35th &amp; Northern Blvd., Long Island City, N. Y.

PERSONNEL: H. J. Kaiser, Sr., Pres.; Z. Soucek, V. Pres.; P. Lockwood, Secy. & Asst. Gen. Counsel; A. B. Cipriani, Controller; J. A. Mitchell, Gen. Mgr.-Prod.; G. W. Hardman, Chief Engr.; F. Lord, Dir. of Sub-Contracting & Procurement; G. A. Luburg, Plant Mgr.; Johnsville, Pa., Div.; C. Santore, Plant Mgr.; E. J. O'Donnell, Dir. of Service; H. O. Fallon, Ind. Rel. Dir.; R. Conc, Labor Rel. Dir.; G. Glehan, Pers. Dir.

**BRIDGEPORT FABRICS, INC.,**

Bridgeport, Conn.

PERSONNEL: H. B. Naramore, Pres.; R. W. Naramore, V. Pres.; E. J. Morrell, Secy.; T. N. Wakeman, Treas.; H. A. Hubbell, Pur. Agt.; L. Spraragen, Chief Engr.

**THE BRIDGEPORT HARDWARE MFG.**

CORP., 461 Iranistan Ave., Bridgeport Conn.

PERSONNEL: H. B. Curtis, Pres.; A. G. Ryan, Secy.; J. F. Windsor, Treas.

**THE BRIDGEPORT SAFETY EMERY**

WHEEL CO., INC., 1299 W. Broad St., Stratford, Conn.

PERSONNEL: L. Wallace, Jr., Pres.; deB. K. Seeley, V. Pres.; A. H. Keen, Treas.

**BRIGGS & STRATTON CORP.,**

2711 N. 13th St., Milwaukee, Wisc.

PERSONNEL: C. L. Coughlin, Pres.; E. V. Oehler, R. W. Griffith, V. Pres.; L. G. Regner, Secy.; E. M. Bodendoerfer, Treas.; R. W. Randall, O. L. Sicker, Sales Mgrs.; J. F. Bode, Pur. Agt.; H. S. Brown, Chief Engr.

**BRIGGS MANUFACTURING CO.,**

11631 Mack Ave., Detroit, Mich.

PERSONNEL: W. P. Brown, Pres. & Gen. Mgr.; W. D. Robinson, V. Pres.; A. D. Blackwood, Secy.; W. O. Briggs, Jr., Treas.; A. J. Wettlaufer, Sales Mgr.; W. J. Cleary, Pur. Agt.; F. H. Taylor, Pers. Dir.; J. Lee, II, Pub. Dir.; E. E. Lundberg, Chief Engr.

**BRIGGS-WEAVER MACHINERY CO.,**

Dallas, Tex.

PERSONNEL: J. B. Dale, Pres., Gen. Mgr. & Sales Mgr.; R. B. Young, V. Pres.; D. C. Dale, Secy. & Treas.; W. C. Jaschob, Pur. Agt.

**THE BRISTOL CO., Waterbury 91, Conn.**

PERSONNEL: H. H. Bristol, Pres.; R. Hazard, Exec. V. Pres.; L. G. Bean, V. Pres.; H. E. Beane, Sales Mgr.; J. W. Peckham, Mgr., Dev. Engrg.; E. Nuber, Western Mgr.; G. P. Lonergan, Sales Promotion Mgr.; A. I. Thompson, Aircraft Instr. Engr.

**BROOKLYN VARNISH MFG. CO., INC.,**

35 Nostrand Ave., Brooklyn, N. Y.

PERSONNEL: W. J. Anderson, Pres.; D. C. Anderson, V. Pres.; R. B. Anderson, Secy.; C. Engelhardt, Gen. Mgr.; J. W. Wilson, Sales Mgr.

# PIONEER\* INSTRUMENTS



NERVE CENTERS OF THE  
MODERN AIRCRAFT

\*TRADE MARK OF BENDIX AVIATION CORPORATION

**ECLIPSE - PIONEER  
DIVISION**  
Teterboro, New Jersey



**ANDREW BROWN CO., 5431 S. Riverside Dr., Los Angeles, Calif.**

PERSONNEL: A. Brown, Pres. & Gen. Mgr.; W. E. Moore, V. Pres. & Chief Engr.; A. M. Roberts, Secy. & Treas.; O. C. Pumphrey, Sales Mgr.; N. Bergeron, Pur. Agt.; J. Franks, Pers. Dir.

**THE BROWN INSTRUMENT CO., Wayne & Roberts Ave., Philadelphia, Pa.**

PERSONNEL: C. B. Sweatt, Pres.; E. B. Evleth, V. Pres. & Gen. Mgr.; J. P. Goheen, Secy.; W. Huff, Treas.; L. M. Morley, Sales Mgr.; J. W. Weingartner, Pur. Agt.; P. L. Goldstrom, Pers. Dir.; J. F. Sullivan, Pub. Dir.; G. M. Muschamp, Chief Engr.

**BROWN & SHARPE MFG. CO.,**

235 Promenade St., Providence, R. I.

PERSONNEL: H. D. Sharpe, Pres. & Treas.; P. C. DeWolf, J. S. Chafee, R. Viall, A. K. Brown, V. Pres.; J. A. Newton, Secy.; A. H. Bainton, Works Mgr.; C. W. Machon, Sales Mgr.; R. W. Dixon, Pur. Agt.; J. J. Hall, Pers. Dir.; J. P. Burdick, Pub. Dir.; B. P. Graves, Chief Engr.

**BRUNNER MANUFACTURING CO.,**

1821 Broad St., Utica, N. Y.

PERSONNEL: G. L. Brunner, Pres.; G. L. Brunner, Jr., V. Pres. & Secy.; A. G. Zumbun, Treas.; P. A. Lovegren, Prod. Mgr.; B. J. Scholl, Sales Mgr.; E. H. Schiller, Pur. Dir.; O. R. McDonald, Adv. Mgr.; S. R. Hirsch, Chief Engr.

**THE BRUSH DEVELOPMENT CO.,**

3311 Perkins Ave., Cleveland 14, O.

PERSONNEL: A. L. Williams, Pres. & Chief Engr.; V. B. Phillips, Exec. V. Pres.; S. J. Begun, V. Pres.; C. B. Sawyer, V. Pres. & Treas.; W. Flory, Secy.; F. Avery, Works Mgr.; L. G. Watson, Prod. Mgr.; B. Foulds, Sales Mgr.; E. R. Parker, Pur. Dir.; W. H. Shelton, Pers. Dir. & Adv. Mgr.

**BRYANT CHUCKING GRINDER CO.,**

Springfield, Vt.

PERSONNEL: R. E. Flanders, Pres.; W. J. Bryant, V. Pres. & Treas.; J. B. Johnson, Gen. Mgr. & Sales Mgr.; J. L. Hronek, Factory Mgr.; E. R. Olney, Pur. Agt.; M. H. Arms, Chief Engr.

**THE BRYANT ELECTRIC CO.,**

1421 State St., Bridgeport, Conn.

PERSONNEL: H. E. Seim, V. Pres. & Gen. Mgr.; S. Booth, Treas.; H. Hey, Sales Mgr.; F. C. Esser, Pur. Agt.; C. L. Sundine, Pers. Dir.; F. F. Herold, Pub. Dir.; C. H. Hodgkins, Chief Engr.

**BUCKEYE IRON & BRASS WORKS,**

324 E. Third St., Dayton 2, O.

PERSONNEL: W. P. Huffman, Pres., Treas. & Gen. Mgr.; R. C. Anderson, V. Pres.; H. W. Webb, Secy. & Sales Mgr.; I. U. Scholl, Prod. Mgr.; E. A. Wenz, Pur. Dir.; B. B. Bains, Adv. Mgr.; F. F. Rike, Chief Engr.

**BUCKEYE TOOLS CORP.,**

29 W. Apple St., Dayton, O.

PERSONNEL: M. J. McCombs, Pres. & Gen. Mgr.; H. O. Gummere, Secy., Sales Mgr. & Pub. Dir.; A. G. Lauzon, Treas.; E. E. Reeves, Pur. Agt.; E. B. Hamilton, Chief Engr.

**THE BUDA CO., Harvey, Ill.**

PERSONNEL: J. S. Dempsey, Pres. & Treas.; R. K. Mangan, Exec. V. Pres. & Sales Mgr.; K. E. Fitzpatrick, Secy.; G. E. Hinkle, Prod. Mgr.; R. C. Wietersen, Pur. Dir.; G. Moecker, Pers. Dir.; H. H. Cohenour, Adv. Mgr.; H. G. Smith, Chief Engr.

**EDWARD G. BUDD MANUFACTURING CO., 25th & Hunting Park Ave., Philadelphia, Pa.**

PERSONNEL: E. G. Budd, Sr., Pres.; E. W. Budd, Jr., D. Alexander, V. Pres.; H. A. Coward, Secy.; P. Zens, Treas.; S. A. Mahan, Works Mgr.; H. P. Curtis, Sales Mgr.; F. S. White, Pur. Agt.; E. H. McIlvain, Pers. Dir.; H. D. Leopold, Pub. Dir.; M. Watter, Aircraft Engr.

**BUFFALO FIRE APPLIANCE CORP.,**

290 Main St., Buffalo 2, N. Y.

PERSONNEL: C. H. Stephens, Pres. & Gen. Mgr.; G. R. Stephens, Works Mgr.; A. G. Sullivan, Sales Mgr.; H. D. Willse, Pur. Dir.; M. F. Hall, Adv. Mgr.; H. C. Smith, Chief Engr.

**BUHL STAMPING CO.,**

2730 Scotten Ave., Detroit, Mich.

PERSONNEL: L. D. Buhl, Pres.; H. S. Finkenstaedt, V. Pres. & Gen. Mgr.; H. E. Ryan, Treas.; E. F. Rickelman, Aviation Sales Mgr.; A. W. Gies, Pur. Agt.; D. Warner, Pers. Dir.; C. D. LaFond, Chief Engr.

**BUHR MACHINE TOOL CO.,**

839 Green St., Ann Arbor, Mich.

PERSONNEL: J. F. Buhr, Pres. & Gen. Mgr.; T. H. L. Backus, V. Pres.; J. F. Haarer, Secy. & Treas.; C. P. Roth, Sales Mgr.; J. H. Buhr, Jr., Pur. Agt.; M. A. Morice, Pers. Dir.; W. J. Mattson, Pub. Dir.; G. D. Evans, Chief Engr.

**BUICK MOTOR DIV., Flint, Mich.**

PERSONNEL: H. H. Curtice, Pres.; I. L. Wiles, Treas.; W. F. Hufstader, Sales Mgr.; L. A. Stewart, Pur. Agt.; R. F. Thalner, Pers. Dir.; F. Webb, Pub. Dir.; C. A. Chayne, Chief Engr.

**THE BULLARD CO.,**

286 Canfield Ave., Bridgeport, Conn.

PERSONNEL: E. P. Bullard, Pres.; E. C. Bullard, V. Pres. & Gen. Mgr.; A. E. North, Secy. & Treas.; E. P. Blanchard, Sales Mgr.; R. T. Phipps, Pur. Agt.; F. H. Somers, Pers. Dir.; R. C. Bullard, Pub. Dir.; V. J. Elsenboss, Chief Engr.

**E. D. BULLARD CO.,**

275 Eighth St., San Francisco, Calif.

PERSONNEL: E. W. Bullard, Pres. & Gen. Mgr.; A. Bull, V. Pres. & Sales Mgr.; R. C. Mills, Pur. Agt.; M. E. Wank, Pub. Dir.

**BUNDY TUBING CO.,**

10951 Hern Ave., Detroit 13, Mich.

PERSONNEL: W. W. Anderson, Pres. & Treas.; A. Gardner, V. Pres.; C. Wright, Secy.; W. C. Ireland, Gen. Mgr.; J. Shanahan, Prod. Mgr.; P. O'Connell, Sales Mgr.; T. Schneider, Pur. Dir.; C. L. Palms, Jr., Pers. Dir.; D. Knox, Chief Engr.

**THE BUNTING BRASS & BRONZE CO.,**

715 Spencer St., Toledo, O.

PERSONNEL: C. E. Bunting, Pres. & Treas.; G. H. Adams, Exec. V. Pres. & Sales Mgr.; D. McKercher, V. Pres. & Gen. Mgr.; W. F. Volk, Secy.; J. Frautschi, Pur. Agt.; G. Yager, Chief Engr.

**BURDETT MFG. CO.,**

19 N. Loomis St., Chicago, Ill.

PERSONNEL: J. B. Burdett, Pres.; J. H. Burdett, V. Pres.; J. E. Veihl, Secy., Treas. & Gen. Mgr.

**BURGESS BATTERY CO.,**

Freeport, Ill.

PERSONNEL: D. W. Hirtle, Pres.; A. M. Dobbs, V. Pres.; O. W. Storey, Secy.; D. J. Teare, Treas.; L. J. Lockwood, Gen. Supt.; J. A. McIlvay, Sales Mgr.; C. A. Butcher, Pur. Dir.; W. C. Morse, Pers. Dir.; C. E. Balz, Adv. Mgr.; J. J. Coleman, Chief Engr.



*Just to be Sure...*

**that Bendix\* Struts  
perform as  
planned**

When Bendix designs a strut for a plane, engineers' estimates of performance are checked by the most modern laboratory equipment. The giant drop-testing machine shown at the right accurately pre-determines the performance of the strut. Dynamometers pre-determine the stopping power of Bendix Airplane Brakes under actual operating conditions. Bending tests measure the resilience and strength of struts, assuring the extra margin of safety upon which lives depend. Bendix inspection facilities are as essential as Bendix engineering leadership in designing and building the right landing gear for every plane.

\* Trademark of Bendix Aviation Corporation



**Bendix\* Landing Gear**—Bendix Pseudraulic Shock Struts, Bendix\* Airplane Wheels, Airplane Brakes, Hydraulic Master Cylinders, and Power Brake Valves are important members of "The Invisible Crew" of precision equipment which more than 30 Bendix plants are speeding to world battle fronts.



**BENDIX PRODUCTS DIVISION, SOUTH BEND, INDIANA**

**BURGESS-NORTON MFG. CO.,**  
756 Peyton St., Geneva, Ill.

**BURKLYN COMPANY,**  
3429 Glendale Blvd., Los Angeles, Calif.  
PERSONNEL: E. Burke. T. Lynn, Partners.

**BURLINGTON MILLS, INC.,**  
Burlington, Wisc.  
PERSONNEL: W. A. McMillan, Pres. & Gen. Mgr.; G. C. Salisbury, V. Pres. & Sales Mgr.; W. G. Rash, Secy. & Treas.; J. C. Wilson, Jr., Prod. Mgr. & Pers. Dir.; H. D. Wakefield, Pur. Dir.; W. C. Fraley, Adv. Mgr.; W. Wagner, Chief Engr.

**BURNDY ENGINEERING CO., INC.,**  
107 Eastern Blvd., New York 54, N. Y.  
PERSONNEL: P. Fried, Pres.; F. E. L. Whitesell, Sales Mgr.; E. C. Tompson, Adv. Mgr.; M. Lee, Chief Engr.

**BURNSIDE VENEER CO., INC.,**  
Burnside, Ky.  
PERSONNEL: R. Kramer, Pres. & Sales Mgr.; M. C. Wilkinson, V. Pres. & Secy.; F. Smith, Treas.

**BURROUGHS WELLCOME & CO., INC.,**  
9 East 41st St., New York, N. Y.  
PERSONNEL: T. Nevin, Pres.; G. S. Dunbar, V. Pres.; W. F. Weber, Secy.; R. C. Ralphs, Treas.; M. S. Smith, Pur. Agt.

**BURTON-ROGERS CO., SALES DIV.,**  
**HOYT ELECTRICAL INSTRUMENT**  
**WORKS, 857 Boylston St., Boston, Mass.**  
PERSONNEL: C. W. Burton, Pres. & Treas.; E. L. Chase, V. Pres.; V. S. Church, Secy. & Chief Engr.

**BUSSMANN MANUFACTURING CO.,**  
University at Jefferson, St. Louis, Mo.  
PERSONNEL: A. B. Bussmann, Pres. & Gen. Mgr.; H. T. Bussmann, V. Pres. & Sales Mgr.; J. A. Bussmann, Secy., Treas. & Pers. Dir.; L. J. Bussmann, Pur. Agt.; H. Thomas, Pub. Dir.; J. Lebens, Chief Engr.

**BUSHINGS, INC.,**  
8-155 General Motors Bldg., Detroit 2, Mich.  
PERSONNEL: B. C. Doying, Pres.; F. E. Wickham, Chief Engr.

**BYRNE DOORS, INC.,**  
1150 Griswold St., Detroit, Mich.  
PERSONNEL: J. I. Byrne, Pres.; G. M. Bolton, V. Pres. & Gen. Mgr.; B. C. Walsh, Secy.; R. Ballantyne, Treas.; E. F. Dunkle, Sales Mgr.; W. B. Lyons, Pur. Agt.; N. E. Colburn, Sr., Chief Engr.

## C

**C-O-TWO FIRE EQUIPMENT CO.,**  
U. S. Highway No. 1, Newark 1, N. J.  
PERSONNEL: S. E. Allen, Pres. & Gen. Mgr.; M. A. Laswell, V. Pres. & Sales Mgr.; E. A. Clapp, Secy. & Treas.; C. W. Michelsen, Prod. Mgr. & Plant Supt.; E. D. Wolf, Pur. Dir.; R. F. Batch, Pers. Dir.; T. O. Young, Pub. Dir. & Adv. Mgr.; F. B. Allen, Chief Engr.

**C & W TOOL CO.,**  
19 Chestnut St., Cambridge, Mass.  
PERSONNEL: A. H. Avery, Pres. & Treas.; J. A. Long, V. Pres., Sales Mgr. & Pers. Dir.; J. B. Harrington, Pur. Agt. & Chief Engr.; R. C. Crichton, Pub. Dir.

**CALIFORNIA PANEL & VENEER CO.,**  
955 S. Alameda St., Los Angeles, Calif.  
PERSONNEL: M. J. Baker, Pres.; G. R. Stratemeyer, V. Pres.; W. F. Fahs, Secy., Treas., Pur. Agt., Pers. Dir. & Pub. Dir.; R. Mulholland, Gen. Mgr. & Sales Mgr.; B. Ostlind, Chief Engr.

**CALIFORNIA SPRING CO., INC.,**  
1746 S. Los Angeles St., Los Angeles, Calif.  
PERSONNEL: J. H. Neuhart, Gen. Mgr.

**THE CALIFORNIA WIRE CLOTH CORP.,**  
1001-22nd Ave., Oakland, Calif.  
PERSONNEL: S. C. Pohlman, V. Pres. & Gen. Mgr.; G. T. Stockfleth, Secy. & Treas.; H. R. Merriam, Sales Mgr.; F. Kelleway, Pur. Agt.; W. de Poy, Chief Engr.

**CAMBRIDGE INSTRUMENT CO., INC.,**  
3732 Grand Central Terminal, New York 17, N. Y.  
PERSONNEL: R. H. Kruse, Pres. & Gen. Mgr.; H. N. Packard, V. Pres. & Treas.; W. H. Jefferson, Secy.; A. A. Clokey, Prod. Mgr.; B. O. Watkins, Aviation Sales Mgr.; L. Birdsall, Pur. Dir.; R. Rick, Adv. Mgr.; U. O. Hutton, Chief Engr.

**CAMLOC FASTENER CORP.,**  
420 Lexington Ave., New York 17, N. Y.  
PERSONNEL: D. S. Kane, Pres. & Gen. Mgr.; D. Kane, V. Pres.; A. W. Faber, Secy. & Treas.; H. J. McCarthy, Sales Mgr.; A. F. Korman, Pur. Dir.; R. W. Allen, Adv. Mgr.; S. W. Hennessey, Jr., Chief Engr.

**CAMPBELL HARDWARE & SUPPLY CO.,**  
108 First, S., Seattle, Wash.  
PERSONNEL: W. Campbell, Pres.; J. Campbell, V. Pres., Treas. & Sales Mgr.; M. Schultz, Secy.; W. Campbell, Gen. Mgr.; J. Leptish, Pur. Dir.

**CANDLER-HILL CORP.,**  
405 Midland Ave., Detroit, Mich.  
PERSONNEL: J. B. Candler, Pres.; E. J. Hill, V. Pres.; G. E. Runyeon, Secy.; B. Ferris, Pur. Agt.; A. G. Schlosser, Chief Engr.

**CANNON ELECTRIC DEVELOPMENT CO.,**  
3209 Humboldt St., Los Angeles 31, Calif.  
PERSONNEL: J. H. Cannon, Pres.; R. J. Cannon, V. Pres.; G. Taylor, Secy.; H. F. Brady, Prod. Mgr.; V. W. Brainard, Sales Mgr.; R. Rowen, Pur. Dir.; A. Wilcox, Pers. Dir.; E. Neifing, Chief Engr.

**EUGENE CANTIN CO., INC.,**  
101 Park Ave., New York 17, N. Y.  
PERSONNEL: E. J. Cantin, Pres. & Gen. Mgr.; V. C. Shadgen, V. Pres. & Treas.; O. Vischi, Secy.

**THE CANTON DROP FORGING & MFG. CO.,**  
Canton, O.  
PERSONNEL: C. A. Brauchler, Pres., Gen. Mgr. & Sales Mgr.; C. H. Brauchler, V. Pres. & Chief Engr.; K. S. Goodin, Secy. & Treas.

**CAPAC MANUFACTURING CO.,**  
Capac, Mich.  
PERSONNEL: T. J. Arbron, Pres.; R. W. Sinclair, V. Pres. & Treas.; J. K. Worley, Secy.; B. Jackson, Prod. Mgr.; F. A. Hooper, Pur. Dir.

**CARBOLOY CO., INC.,**  
1177 E. 8 Mile Rd., Detroit, Mich.  
PERSONNEL: W. G. Robbins, Pres.; A. MacKenzie, V. Pres.; K. R. Oberle, Treas.; J. R. Longwell, Gen. Mgr.; K. R. Beardslee, Sales Mgr.; A. DeCarlo, Pur. Agt.; F. C. Ritner, Pers. Dir.; E. C. Howell, Pub. Dir.; P. Miller, Chief Engr.



## FIGHT TO THE FINISH

Those who work on the Bendix-Scintilla\* Aircraft Magnets that spark our warplanes know that this is a fight to the finish . . . even to the "finish" of a single steel cam. Creative engineering must go hand in hand with unsurpassed precision in manufacture. Bendix-Scintilla has accomplished many major developments in Aircraft Ignition, but the firing line is still the final test . . . of magnets as of men. And Bendix-Scintilla will carry on, unrelentingly, its own special "fight to the finish."

**SCINTILLA MAGNETO DIVISION**  
 SIDNEY, N. Y.



\*TRADE MARK OF BENDIX AVIATION CORPORATION





**CARDOX CORP.,**

307 N. Michigan Ave., Chicago 1, Ill.  
**PERSONNEL:** A. Harris, Pres.; J. H. Bell, Exec. V. Pres.; E. Geerts, C. A. Getz, V. Pres.; J. J. Fitzgerald, Secy.; H. R. Baldwin, Treas.; H. W. Lange, Sales Mgr.; M. H. Hemman, Pur. Dir.; G. W. Adrianson, Pers. Dir.; J. N. Krohne, Pub. Dir.; H. R. Harper, Chief Engr.

**CHAS. W. CARLL SONS,**

Cole St. & Reading R. R., Trenton 8, N. J.  
**PERSONNEL:** C. M. Carll, Pres., Gen. Mgr. & Chief Engr.; M. G. Newell, Secy., Treas. & Pers. Dir.; W. Schurter, Prod. Mgr.; J. W. Carll, Sales Mgr., Pur. Dir., Pub. Dir. & Adv. Mgr.

**THE CARLYLE JOHNSON MACHINE CO.,**

52 Main St., Manchester, Conn.  
**PERSONNEL:** S. H. Simon, Pres. & Sales Mgr.; A. R. Coc, V. Pres., Pur. Dir. & Chief Engr.; A. B. Clough, Secy.; J. M. Miller, Treas.; W. McBride, Prod. Mgr.

**CARNEGIE-ILLINOIS STEEL CORP.,**

Carnegie Bldg., 434 Fifth Ave., Pittsburgh 30, Pa.  
**PERSONNEL:** J. L. Perry, Pres.; D. F. Austin, V. Pres.-Sales; J. W. Hamilton, Secy.; L. F. Payne, Treas.; T. J. Hilliard, Gen. Mgr. of Sales; F. J. Rief, Pur. Dir.; R. J. Greenly, Chief, Personnel Div.; G. R. Schreiner, Adv. Mgr.; M. W. Reed, Chief Engr.

**THE E. W. CARPENTER MFG. CO.,**

1565 Railroad Ave., Bridgeport, Conn.  
**PERSONNEL:** H. C. Wheeler, Pres.; M. B. Butler, V. Pres. & Gen. Mgr.; D. W. Clark, Secy. & Treas.; J. J. Morrison, Prod. Mgr.; I. Noonan, Sales Mgr.; K. Trefry, Pur. Dir.; E. Dalton, Pers. Dir.; W. H. Fry, Chief Engr.

**THE CARPENTER STEEL CO.,**

Reading, Pa.  
**PERSONNEL:** J. H. Parker, Pres.; F. R. Palmer, V. Pres.-Sales; E. J. Poole, Jr., V. Pres.-Mgr.; J. S. Pendleton, Secy. & Treas.; R. V. Mann, Sales Mgr.; R. P. Freehafer, Pur. Dir.; C. F. Weaver, Pers. Dir.; A. E. Keller, Adv. Mgr.; B. H. DeLong, Chief Met.

**CARRIER CORP.,**

S. Geddes St., Syracuse 1, N. Y.  
**PERSONNEL:** E. C. Wampler, Pres. & Gen. Mgr.; E. T. Murphy, Sr., V. Pres. & Sales Mgr.; J. H. Holton, V. Pres. & Prod. Mgr.; H. L. Laube, V. Pres. & Chief Engr.; W. H. Driscoll, V. Pres. & Pur. Dir.; M. E. Snyder, Secy. & Treas.; R. Ebberts, Pers. Dir.; W. A. Bowe, Pub. Dir. & Adv. Mgr.

**CARTER MOTOR COMPANY,**

1608 Milwaukee Ave., Chicago, Ill.  
**PERSONNEL:** A. J. Carter, Pres.; R. W. Carter, V. Pres. & Chief Engr.; E. J. Detsch, Secy.; B. R. Carter, Treas.; J. M. Mattheis, Pur. Agt.

**A. T. CASE CO.,**

6100 Avalon Blvd., Los Angeles, Calif.  
**PERSONNEL:** A. T. Case, Pres.; J. G. Campazzie, Secy. & Gen. Mgr.; J. K. Doan, Treas.; E. A. Evans, Sales Mgr.; L. Inman, Pur. Agt.; H. Derner, Pers. Dir.; H. Childers, Chief Engr.

**CASEIN CO. OF AMERICA,**

350 Madison Ave., New York 17, N. Y.  
**PERSONNEL:** W. Callan, Pres.; W. F. Leicester, V. Pres.; B. B. Wadsworth, Sales Mgr.; A. M. Freeman, Adv. Mgr.

**CASTALLOY CO., INC.,**

220 Sixth St., Cambridge, Mass.  
**PERSONNEL:** F. Hengesch, Pres.; F. McConville, Treas.

**CATALIN CORP.,**

One Park Ave., New York 10, N. Y.  
**PERSONNEL:** W. Thiele, Pres.; H. Krehbiel, V. Pres.; E. S. Horstman, Adv. Mgr.; L. Beck, Chief Engr.

**CEE BEE CHEMICAL CO., INC.,**

655 E. Gage Ave., Los Angeles, Calif.  
**PERSONNEL:** S. C. Black, Pres.; C. D. Black, Secy. & Treas.; D. Wright, Asst. Gen. Mgr.

**CELANESE CELLULOID CORP.,**

180 Madison Ave., New York 10, N. Y.  
**PERSONNEL:** C. Dreyfus, Pres.; E. W. Ward, Gen. Sale. Mgr.; F. W. Paffen, Pur. Dir.; H. E. Raymond, Adv. Mgr.

**THE CENTERLESS GRINDING CO. INC.,**

19 Staples St., Bridgeport 1, Conn.  
**PERSONNEL:** W. Hobera, Pres. & Treas.

**CENTRAL SCREW CO.,**

3501 Shields Ave., Chicago 9, Ill.  
**PERSONNEL:** H. F. Kellogg, Pres. & Treas.; D. S. Jennings, V. Pres. & Secy.; E. Payne, Sales Mgr.; A. Hahn, Dev. Engr.; W. Roche, Chief Engr.

**CENTURY AIRCRAFT COMPANY,**

5601 Century Blvd., Los Angeles, Calif.  
**PERSONNEL:** J. M. Henry, Gen. Mgr.

**CENTURY ELECTRIC CO.,**

1806 Pine St., St. Louis 3, Mo.  
**PERSONNEL:** E. S. Pillsbury, Pres.; R. J. Russell, V. Pres. & Secy.; G. Smith, V. Pres. & Gen. Mgr.; J. L. Woodress, Dir. of Sales; J. F. Culver, Treas.; R. N. Hill, Works Mgr.; E. S. Moore, Sales Mgr.; G. Prosser, Pur. Dir.; T. Ganley, Pers. Dir.; O. S. Imes, Adv. Mgr.; S. S. Wolff, Chief Elec. Engr.

**CENTURY METALCRAFT CORP., MFG. DIV.,**

6000 Avalon Blvd., Los Angeles, Calif.  
**PERSONNEL:** H. P. Dwyer, Pres.; C. J. Amick, V. Pres., Gen. Mgr. & Sales Mgr.; G. V. Groh, Secy.; E. P. Carson, Treas. & Pur. Agt.; A. Alberts, Pers. Dir.; P. Kliment, Chief Engr.

**CHAMPION AVIATION PRODUCTS CO.,**

1702 S. Flower St., Los Angeles, Calif.  
**PERSONNEL:** H. P. Lester, Pres., Gen. Mgr. & Sales Mgr.; T. B. Smallwood, V. Pres. & Chief Engr.; V. C. Hodges, Secy. & Treas.

**CHAMPION BLOWER & FORGE CO.,**

Lancaster, Pa.  
**PERSONNEL:** C. B. Long, Pres.; O. H. Hertzler, V. Pres.; C. R. Appel, Secy.; H. K. Long, Treas.

**CHAMPION PNEUMATIC MACHINERY CO.,**

8162 S. Chicago Ave., Chicago 17, Ill.  
**PERSONNEL:** G. T. Rayfield, Pres., Gen. Mgr. & Pur. Dir.; F. J. Rayfield, V. Pres., Treas. & Chief Engr.; C. H. Lee, Secy., Sales Mgr. & Adv. Mgr.

**CHAMPION SPARK PLUG CO.,**

Upton Ave., Toledo 1, O.  
**PERSONNEL:** R. A. Stranahan, Pres.; D. Stranahan, V. Pres.; R. H. Rowland, V. Pres.-Sales; M. C. Dewitt, V. Pres. & Adv. Mgr.; H. B. Speyer, Secy. & Asst. Treas.; F. D. Stranahan, Treas.; B. H. Sibley, Factory Mgr.; B. O. Black, Prod. Mgr.; C. L. Corwin, Sales Mgr.; J. F. Lewis, Jr., Pur. Dir.; J. H. Beatty, Supervisor of Employee Rel.; J. Nolan, Prod. Engr.



**TO CARRY FIGHTER PROTECTION**

*Farther!*



**STROMBERG\*  
Injection Carburetor**

The Stromberg Aircraft Carburetor is an important member of "The Invisible Crew"... precision instruments, and controls, which Bendix plants from coast to coast are speeding to our fighting crews on world battle fronts.

• On the new North American P-51 Mustang fighter planes that escort American heavy bombers to the innermost war centers of Germany, Stromberg<sup>®</sup> Injection Carburetors help assure the *fuel economy* that makes such long-range missions possible. By compensating quickly and automatically for all changes in speed, altitude, attitude and temperature, Stromberg Carburetors also help to make the Mustang the highest climbing and fastest flying fighter in existence.

\* Trademark of Bendix Aviation Corporation



**BENDIX PRODUCTS DIVISION OF BENDIX AVIATION CORPORATION • SOUTH BEND, INDIANA**

**CHANDLER-EVANS CORP.,**

S. Meriden, Conn.

PERSONNEL: C. W. Deeds, Pres.; B. H. Gilpin, V. Pres., Treas. & Gen. Mgr.; M. E. Chandler, V. Pres.-Engrg.; H. L. Hartman, Asst. Gen. Mgr.; G. H. Day, Secy.; H. T. Rich, Pur. Agt.; W. F. Skillin, Chief Engr.

**T. M. CHAPMAN'S SONS CO.,**

60 Center St., Old Town, Me.

PERSONNEL: H. W. Chapman, Pres.; F. K. Chapman, Treas. & Pur. Agt.

**L. C. CHASE & CO.,**

295 Fifth Ave., New York, N. Y.

PERSONNEL: W. H. Marland, Pres.; W. A. Spicer, V. Pres.; T. M. Goodall, Treas.; G. B. Ogan, Gen. Mgr.

**CHASE BRASS & COPPER CO.,**

263 Grand St., Waterbury 91, Conn.

PERSONNEL: C. E. Hart, Pres.; R. L. Coe, V. Pres. & Sales Mgr.; R. D. Ely, V. Pres.; S. S. Jackson, Secy.; J. H. Gilbert, Treas.; A. G. Evans, Pur. Dir.; R. Chase, Pub. Dir. & Adv. Mgr.; R. W. Shoemaker, Chief Engr.

**JOHN CHATILLON & SONS,**

85 Cliff St., New York 7, N. Y.

PERSONNEL: G. E. Chatillon, Pres.; A. J. Chatillon, V. Pres.; E. M. Haines, Sales Mgr.; W. K. Slatford, Pur. Dir.

**CHERRY RIVET CO.,**

1819 Barranca St., Los Angeles, Calif.

PERSONNEL: W. B. Hubbard, Pres. & Gen. Mgr.; W. Kinney, V. Pres.; R. Kinney, Secy.; H. D. Crookston, Treas.; M. C. Ketchum, Sales Mgr.; E. C. Conard, Pur. Agt.; D. T. Prince, Pers. Dir.; A. S. Mullgardt, Chief Engr.

**CHICAGO AERIAL SURVEY CO.,**

332 S. Michigan Ave., Chicago 4, Ill.

PERSONNEL: E. W. Fuller, Pres.; F. T. Sonne, V. Pres.; J. L. Patzold, Pur. Dir.

**CHICAGO METAL HOSE CORP.,**

1315 S. Third Ave., Maywood, Ill.

PERSONNEL: J. F. P. Farrar, Pres.; A. S. Keller, V. Pres.-Sales & Adv. Mgr.; A. E. F. Johnson, V. Pres.-Prod.; D. W. Fentress, V. Pres.-Engrg.; T. M. Sinclair, Pur. Dir.; T. H. Ryan, Pers. Dir.

**CHICAGO PNEUMATIC TOOL CO.,**

6 E. 44th St., New York 17, N. Y.

PERSONNEL: H. A. Jackson, Pres.; W. L. Lewis, V. Pres.; L. S. Gillette, Sales Dev. Mgr., Pers. Dir. & Pub. Dir.; M. Powers, Pur. Dir.; J. A. Sullivan, Adv. Mgr.

**CHICAGO RAWHIDE MANUFACTURING**

CO., 1301 Elston Ave., Chicago, Ill.

PERSONNEL: E. W. Emery, Pres.; S. E. Ullmann, V. Pres.; M. A. Schiltz, Secy. & Treas.; E. E. Frodin, Pur. Agt.; R. O. Isenbarger, Chief Engr.

**CHICAGO RIVET & MACHINE CO.,**

9600 W. Jackson Blvd., Bellwood, Ill.

PERSONNEL: J. A. Morrissey, Pres., Gen. Mgr. & Pers. Dir.; H. J. Tonn, V. Pres. & Chief Engr.; M. F. McManus, V. Pres.; E. J. Morrissey, Secy. & Sales Mgr.; E. P. O'Malley, Jr., W. Bautz, Pur. Agt.; R. C. Hudson, Pub. Dir.

**CHISHOLM-MOORE HOIST CORP.,**

Tonawanda, N. Y.

PERSONNEL: F. T. Stone, Pres.; A. L. McKinnon, V. Pres.; J. H. Goodwin, Secy. & Treas.; L. B. Gilbert, Prod. Mgr.; D. S. Brisbin, Sales Mgr.; W. J. Wolf, Pur. Dir.; R. E. Gerspacher, Adv. Mgr.; H. F. Parker, Chief Engr.

**CHRYSLER CORP.—AMPLEX DIV.,**

6501 Harper Ave., Detroit, Mich.

PERSONNEL: A. J. Langhammer, Pres.; R. H. Khuen, Sales Mgr.; A. H. Merschel, Pur. Agt.; M. L. Cobb, Pers. Dir.

**CINCH MANUFACTURING CORP.,**

2335 W. Van Buren St., Chicago, Ill.

PERSONNEL: W. G. Roby, Pres.; J. J. Steffen, V. Pres. & Gen. Mgr.; C. C. Wilson, V. Pres. & Sales Mgr.; J. R. Nicholson, Secy.; A. W. Kimbell, Treas.; C. J. Flanagan, Prod. Mgr.; T. A. Hopkins, Pur. Dir.; R. G. Kimbell, Sr., Pers. Dir.; D. T. Campbell, Adv. Mgr.; C. L. Knutson, Chief Engr.

**THE CINCINNATI LATHE & TOOL CO.,**

3207-11 Disney St., Oakley, Cincinnati,

O.

PERSONNEL: W. C. Heindel, Pres.; M. E. Rogers, Secy.

**CINCINNATI MILLING AND GRINDING**

MACHINES, INC., Marburg Ave.,

Oakley, Cincinnati 9, O.

PERSONNEL: F. V. Geier, Pres.; W. W. Tange-man, V. Pres. & Gen. Mgr.; F. M. Angevin, Secy. & Pur. Dir.; P. O. Geier, Treas.; C. Somogyi, Prod. Mgr.; S. E. Bergstrom, Sales Mgr.; O. P. Geier, Pers. Dir.; C. M. Reese, Pub. Dir. & Adv. Mgr.; L. F. Nenninger, Chief Engr.

**THE CINCINNATI PLANER CO.,**

3120 Forrer St., Cincinnati, O.

PERSONNEL: B. B. Quillen, Pres.; G. Langen, V. Pres.; R. J. Steiner, Secy.; G. D. Walker, Treas.; V. F. Schooffield, Gen. Mgr.; R. D. Allison, Sales Mgr.; J. W. Knipping, Pur. Agt.; L. D. Klayer, Pers. Dir.; J. D. Daugherty, Chief Engr.

**THE CINCINNATI SHAPER CO.,**

Hopple, Garrard &amp; Elam, Cincinnati 25,

O.

PERSONNEL: P. G. March, III, Pres.; H. S. Robinson, Secy., Treas. & Gen. Mgr.; R. D. Wade, Prod. Mgr.; F. H. Pfefferle, Sales Mgr.; H. Fenner, Pur. Dir.; F. W. Pfaff, Pers. Dir.; A. G. Baumgartner, Pub. Dir. & Adv. Mgr.; R. S. Diserens, Chief Draftsman.

**CIRCO PRODUCTS CO.,**

2835 Chester Ave., Cleveland 14, O.

PERSONNEL: J. F. Black, Pres., Treas. & Gen. Mgr.; J. J. Skelly, V. Pres.; P. E. Leas, Secy.; S. J. Polcar, Prod. Mgr.

**C. P. CLARE & CO.,**

4719 Sunnyside Ave., Chicago, Ill.

PERSONNEL: C. P. Clare, Pres.; J. E. Mossman, V. Pres.; J. I. McTaggart, Secy.

**GEO. P. CLARK CO.,**

Windsor Locks, Conn.

PERSONNEL: G. E. Clark, Pres. & Treas.; L. C. Hunter, Secy.; C. W. Russell, Prod. Mgr.; A. W. Bevin, Sales Mgr.; E. M. Williams, Pur. Dir.

**CLARK TRUCTRACTOR DIV. OF CLARK**

EQUIPMENT CO., Battle Creek, Mich.

**CLAROSTAT MFG. CO., INC.,**

285 N. Sixth St., Brooklyn, N. Y.

PERSONNEL: J. J. Mucher, Pres.; S. J. Mucher, Secy.; J. Mucher, Treas.; V. Mucher, Gen. Mgr., Sales Mgr. & Pur. Agt.; C. Burnell, Pers. Dir.; G. J. Mucher, Chief Engr.

**CLAYTON MANUFACTURING CO.,**

501 S. Marengo Ave., Alhambra, Calif.

PERSONNEL: W. Clayton, Pres.; L. F. Working, V. Pres.; J. A. Cortright, Sales Mgr.; J. E. St. Clair, Gen. Mgr.

*Dependable*

# CHAMPION SPARK PLUGS

AVAILABLE FOR ALL ENGINES  
IN BOTH RADIO SHIELDED AND UNSHIELDED TYPES

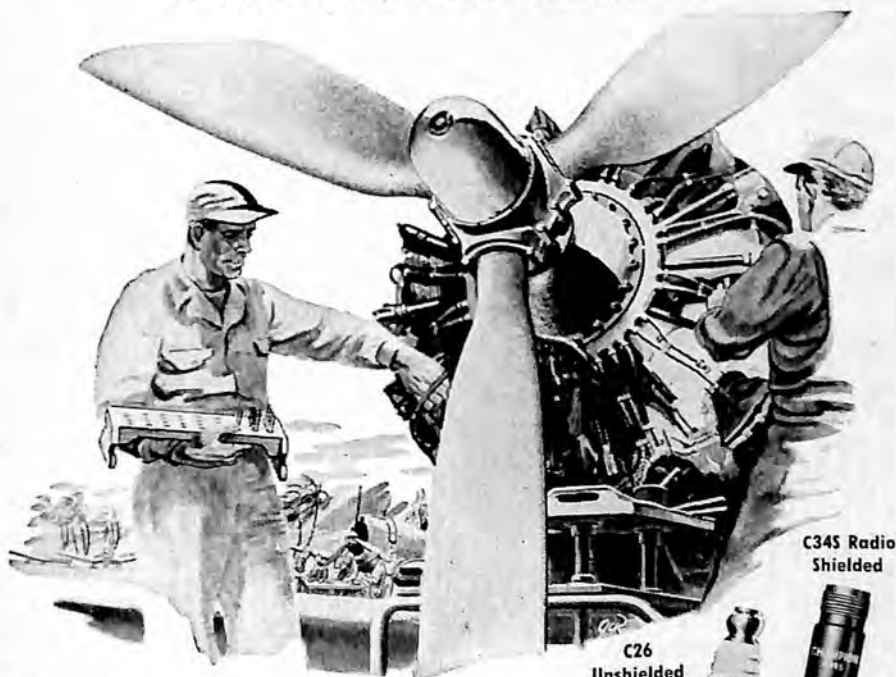

C34S Radio  
Shielded

C26  
Unshielded



Champion Ceramic Aircraft Spark Plugs, like all Champions for over thirty years, have earned a reputation for making every engine a better performing, more dependable engine.

This is directly due to certain inherent characteristics that stem basically from the specially developed ceramic insulation and other exclusive and patented features around which all Champion Aircraft

Spark Plugs are designed.

Proof of the outstanding performance and dependability of

Champions in engines of every size and type is the fact that the demand for them has continued to accelerate, unabated ever since their introduction.

Champion Spark Plug Company • Toledo, (1), Ohio  
Windsor, Canada • Feltham, England



**INSTALL CHAMPIONS AND FLY WITH CONFIDENCE**

**THE CLEVELAND AUTOMATIC MACHINE CO.,** 2269 Ashland Rd., Cleveland, O.

PERSONNEL: A. L. Patrick, Pres. & Gen. Mgr.; G. V. Patrick, V. Pres.; D. L. Johnson, Secy.; J. Hammond, Treas.; G. A. Collier, Sales Mgr.; H. E. Lemmerman, Pur. Agt.; E. Bottle, Pers. Dir.; L. C. Cole, Chief Engr.

**THE CLEVELAND GRAPHITE BRONZE CO.,** 1700 St. Clair Ave., Cleveland 10, O.

PERSONNEL: B. F. Hopkins, Pres.; J. J. McIntyre, J. L. Myers, C. W. Johnson, J. V. O. Palm, V. Pres.; D. R. Schoales, Treas.; J. L. Sullivan, Prod. Mgr.; L. W. Christenson, Sales Mgr.; A. G. Mould, Pur. Dir.; H. E. Fuller, Pers. Dir.; E. Howard, Pub. Dir. & Adv. Mgr.

**THE CLEVELAND METAL STAMPING CO.,** 3110 Payne Ave., Cleveland, O.

PERSONNEL: H. G. Thompson, Pres.; E. J. Thompson, V. Pres.; C. R. Thompson, Secy., Sales Mgr. & Pur. Agt.; G. H. Thompson, Treas., Gen. Mgr., Pur. Agt. & Chief Engr.; C. Habart, Pers. Dir.

**THE CLEVELAND PNEUMATIC TOOL CO.,** 3781 E. 77th St., Cleveland 5, O.

PERSONNEL: D. C. Green, Pres. & Gen. Mgr.; H. W. Foster, F. B. Greve, V. Pres.; R. L. Welborn, V. Pres.-Mfg. & Prod. Mgr.; H. B. Collins, Secy.; J. S. Clark, Treas.; W. C. Wehnes, Pur. Dir.; M. O. Halliwill, Pers. Dir.; J. E. Dillon, Pub. Dir.; E. L. Oldham, Adv. Mgr.

**Aircraft Div.**

PERSONNEL: E. W. Cleveland, Sales Rep.; J. F. Wallace, Chief Engr.

**Rock Drill Div.**

PERSONNEL: R. R. Morgan, Sales Mgr.; R. R. Richardson, Chief Engr.

**Pneumatic Tool Div.**

PERSONNEL: E. J. Steger, Sales Mgr.; P. Van-sittert, Chief Engr.

**THE CLEVELAND PUNCH & SHEAR WORKS CO.,** 3917 St. Clair Ave., Cleveland 14, O.

PERSONNEL: W. C. Sayle, Pres. & Gen. Mgr.; H. J. Corrin, V. Pres. & Treas.; P. J. Hopkins, Prod. Mgr.; A. J. Fitzgerald, Sales Mgr.; J. M. Berry, Pur. Dir.; W. J. Stewart, Pers. Dir. & Adv. Mgr.; W. F. Longfield, Chief Engr.

**CLEVELAND TANNING CO.,**

Denison Ave. at Jennings Rd., Cleveland 9, O.

PERSONNEL: F. R. Wilhelmy, Pres. & Gen. Mgr.; J. McKay, V. Pres.; E. D. Kane, Secy. & Pur. Dir.; M. C. Howe, Treas.; J. Honacker, Prod. Mgr.

**THE CLEVELAND TOOL ENGINEERING CO.,** 9206 Detroit Ave., Cleveland, O.

PERSONNEL: C. E. Walling, Owner; C. M. Simpson, V. Pres.; V. H. Walling, Sales Mgr.

**CLEVELAND TUNGSTEN, INC.,**

10200 Meech Ave., Cleveland, O.

PERSONNEL: E. O. Oberdick, Pres.; W. E. Mansfield, V. Pres. & Gen. Mgr.; J. B. Oviatt, Secy.; R. M. Cira, Treas.

**CLIFFORD MANUFACTURING CO.,**

564 E. First St., Boston, Mass.

PERSONNEL: W. B. Clifford, Pres.; J. E. Woods, V. Pres.; F. J. Howe, Treas.; J. C. Vitosky, Prod. Mgr.; E. F. Wilcox, Pur. Dir.; J. H. Howard, Chief Engr.

**CLUFF FABRIC PRODUCTS,**

457-467 E. 147th St., Bronx, N. Y.

PERSONNEL: J. Grohs, Gen. Mgr. & Pur. Dir.; B. Sheer, Prod. Mgr.; W. R. Harris, Sales Mgr.; W. Heimowitz, Pers. Dir., Pub. Dir. & Adv. Mgr.

**COLE-HERSEE CO.,**

54 Old Colony Ave., S. Boston 27, Mass.

PERSONNEL: L. Mayer, Pres., Treas., Gen. Mgr. & Sales Mgr.; B. Levin, V. Pres.; F. S. Carpenter, Prod. Mgr. & Pers. Dir.; M. Shulman, Pur. Dir.; S. L. Kamsler, Pub. Dir. & Adv. Mgr.; T. Unsworth, Chief Engr.

**COLGATE AIRCRAFT CORP.,**

S. Bayview Ave., Amityville, N. Y.

PERSONNEL: G. Colgate, Pres.; N. K. Colgate, Secy. & Treas.; H. U. Zimmer, Prod. Mgr.; W. J. Starr, Procurement Mgr.; A. R. Miller, Pers. Mgr.; H. F. Inskip, Chief Engr.

**COLLINS & AIKMAN CORP.,**

200 Madison Ave., New York, N. Y.

PERSONNEL: W. G. McCullough, Pres.; C. M. Willon, Secy.; C. B. Rockwell, Treas.; P. B. Baldwin, Sales Mgr.; S. C. Lukens, Pur. Agt.; W. Gill, Pers. Dir.; M. F. Schmitt, Pub. Dir.

**COLLINS-POWELL CO.,**

9247 Alden Dr., Beverly Hills, Calif.

**COLLYER INSULATED WIRE CO.,**

Pawtucket, R. I.

PERSONNEL: V. C. B. Wetmore, Pres.; F. Crook, V. Pres.; R. C. Moeller, Secy., Treas. & Gen. Mgr.; J. H. Brennan, Sales Mgr. & Pub. Dir.; R. D. Moeller, Pur. Agt.; E. S. Brinker, Pers. Dir.; E. S. Day, Chief Engr.

**COLT'S PATENT FIRE ARMS MANUFACTURING CO.,** 17 Van Dyke Ave., Hartford, Conn.

PERSONNEL: S. M. Stone, Pres.; H. D. Fairweather, Exec. Vice Pres.; D. G. Phelps, B. F. Conner, G. R. Porter, V. Pres.; E. Sather, Secy.; L. T. Goodrich, Treas.; J. E. Hewes, Pur. Agt.; C. F. Lindberg, Pers. Dir.; L. B. Wilson, Adv. Mgr.

**COLUMBIA STAMPING & MFG. CORP.,**

217 E. 17th St., Los Angeles, Calif.

PERSONNEL: C. W. Bohman, Pres. & Gen. Mgr.; T. E. Franklin, V. Pres.; A. J. Bohman, Secy., Treas. & Chief Engr.; G. Rogers, Pur. Agt.; C. Bohman, Pers. Dir.

**COLUMBIA STEEL CO.,**

Russ Bldg., San Francisco 6, Calif.

PERSONNEL: W. A. Ross, Pres.; O. L. Pringle, V. Pres.-Operations; F. B. DeLong, V. Pres. & Gen. Mgr. of Sales; E. H. Daniels, Treas.; H. W. Christensen, Pur. Dir.; H. T. Lintott, Pers. Dir.; R. E. Williams, Adv. Mgr.; P. F. Kohlhaas, Chief Engr.

**THE COLUMBIAN VISE & MFG. CO.,**

9021 Bessemer Avenue, Cleveland, O.

PERSONNEL: D. C. Swander, Pres. & Gen. Mgr.; H. F. Seymour, V. Pres., Sales Mgr. & Pub. Dir.; D. C. Swander, Jr., Secy. & Prod. Mgr.; A. F. Munnhall, Treas. & Adv. Mgr.; A. S. Trivison, Pur. Dir.

**COLUMBUS COATED FABRICS CORP.,**

Seventh & Grant Aves., Columbus 16, O.

PERSONNEL: O. C. Altmaier, Pres. & Gen. Mgr.; H. E. Nesbitt, V. Pres. & Gen. Sales Mgr.; C. S. Hyatt, V. Pres. & Prod. Mgr.; J. W. Willcox, Secy. & Treas.; S. N. McCloud, Pur. Dir.; A. Shutt, Adv. Mgr.; H. H. Brooks, Chief Engr.

**COLUMBUS PLASTIC PRODUCTS, INC.,**

519 Dublin Ave., Columbus, O.

PERSONNEL: G. W. Keny, Pres., Gen. Mgr. & Pers. Dir.; W. C. Keny, V. Pres.; W. J. Braley, Secy., Treas. & Pur. Dir.; L. M. Durrett, Prod. Mgr.; B. W. Hively, Sales Mgr., Pub. Dir. & Adv. Mgr.; N. W. Roop, Chief Engr.



**BOTTLENECKS**  
**DAMN THE TORPEDOES**  
**FULL SPEED AHEAD!**

Making only Mounted Wheels and small Grinding Wheels—maintaining highest quality in spite of large quantities and rush orders—shipping them promptly. **This is our job, our battlefield.**

With full WPB approval, we stopped making all large size grinding wheels and fixed our sights on wheels 3" in diameter and under.

We worked all around the clock, 24 hours a day, and in a short time were able to fill orders on time—And, our central location cuts time in transit. Today, there is no waiting. With the Army-Navy E at our masthead, we are going full speed ahead.



**TEST WHEEL FREE**

To get acquainted with Chicago Wheels, let us send one postpaid. Tell us size wheel and material you wish to grind.

**WRITE FOR ILLUSTRATED CATALOG**

**CHICAGO WHEEL & MFG. CO.**

1101 W. MONROE ST., DEPT. AB, CHICAGO 7, ILL.

\* Half a century of specialization has established our reputation as the Small Wheel People of the Abrasive Industry. You can bank on us



**COMMERCIAL CHEMICAL CO., INC.,**

Charlestown, Mass.  
PERSONNEL: G. Virtue, Pres.

**COMMERCIAL PLASTICS CO.,**

201 N. Wells St., Chicago 6, Ill.  
PERSONNEL: C. R. Overholser, Pres.; R. J. Mott, V. Pres.; G. Bushing, Secy.; M. J. McCrory, Treas.

**COMMONWEALTH INDUSTRIES, INC.,**

5922 Commonwealth, Detroit, Mich.  
PERSONNEL: C. G. Heilman, Pres. & Gen. Mgr.; H. W. Stark, V. Pres.; M. Hulett, Secy. & Treas.; D. M. Fleming, Sales Mgr.; C. Oldenburg, Pur. Agt.; R. M. Neff, Chief Engr.

**COMMUNICATIONS CO., INC.,**

300 Greco Ave., Coral Gables, Fla.  
PERSONNEL: G. E. Smith, Pres. & Gen. Mgr.; F. B. Smith, Asst. Secy. & Asst. Treas.; F. M. Nordman, Prod. Mgr.; B. J. Wayne, Pur. Dir.; G. A. Leap, Dev. Engr.

**COMPTON METALS CO.,**

Box 383, Compton, Calif.

**CONNECTICUT HARD RUBBER CO.,**

407 East St., New Haven, Conn.  
PERSONNEL: J. A. Moffitt, Pres.; C. M. Doede, V. Pres.; E. Clohessy, Prod. Mgr.; J. W. Pulleya, Sales Mgr.; B. J. Humphrey, Chief Engr.

**THE CONNEANT LEATHER CO.,**

Conneant, O.  
PERSONNEL: C. L. Whitney, Pres. & Gen. Mgr.; W. C. Whitney, V. Pres.; E. C. Whitney, Secy.; M. Bennett, Treas.

**CONNECTICUT TELEPHONE & ELECTRIC CORP.,**

70 Britannia St., Meriden, Conn.  
PERSONNEL: H. W. Harwell, Pres.; A. B. Chace, F. W. Watts, V. Pres.; C. A. Cunneen, Secy. & Treas.; G. E. Lundquist, Sales Mgr.; A. Ferguson, Pur. Agt.; W. S. Barlow, Pers. Dir.; W. R. Curtiss, Chief Engr.

**CONSOLIDATED ENGINEERING CORP.,**

1255 E. Green St., Pasadena, Calif.  
PERSONNEL: H. Hoover, Jr., Pres.; P. S. Fogg, Exec. V. Pres.; E. A. Pielemeier, Secy.; E. W. Cairns, Treas.; W. E. Spicer, Prod. Mgr.; E. E. Hoskins, Chief Engr.

**CONSOLIDATED MACHINE TOOL CORP.,**

565 Blossom Rd., Rochester, N. Y.  
PERSONNEL: A. H. Ingle, Pres.; A. Trosch, V. Pres., Gen. Mgr., Sales Mgr. & Chief Engr.; A. H. Burnett, Secy.; W. O. Ingle, Treas.; H. E. Hubbard, Pur. Agt.; C. Kalbfuss, Pers. Dir.; H. M. Bowman, Pub. Dir.

**CONSOLIDATED RADIO PRODUCTS CO.,**

350 W. Erie, Chicago, Ill.  
PERSONNEL: R. B. Smith, Pres.; E. A. Heppner, V. Pres.; H. Moskow, Gen. Mgr.; J. Major, Prod. Mgr.; J. Keim, Sales Mgr.; E. Sladkey, Pur. Dir.; J. C. Phalen, Chief Engr.

**CONTINENTAL CAN CO., INC.,**

100 E. 42nd St., New York 17, N. Y.  
PERSONNEL: C. C. Conway, Pres.; J. B. Jeffress, Jr., V. Pres.; S. McKewen, Secy. & Treas.; W. H. Funderburg, V. Pres.-Sales; R. M. Schrader, Pur. Agt.; R. R. Carlier, Pub. Dir. & Adv. Mgr.

**CONTINENTAL-DIAMOND FIBRE CO.,**

Newark, Del.  
PERSONNEL: J. P. Wright, Pres.; N. N. Wright, V. Pres. & Sales Mgr.; F. K. Simons, Secy.; J. A. Ranck, Treas.; J. F. Anderson, Gen. Mgr.; R. Stewart, Prod. Mgr.; W. H. Walker, Jr., Pur. Dir.; N. W. Sieber, Adv. Mgr.; C. S. Rankin, Chief Engr.

**CONTINENTAL INDUSTRIAL ENGINEERS,**

INC., 201 N. Wells St., Chicago, Ill.  
PERSONNEL: W. A. Darrah, Pres., Treas. & Gen. Mgr.; E. B. Jones, V. Pres. & Chief Engr.; L. Reilly, Secy.; K. A. Hastings, Sales Mgr. & Pers. Dir.; C. P. Masure, Pur. Agt.

**CONTINENTAL MACHINES INC.,**

1301 Washington Ave., S. Minneapolis 4, Minn.  
PERSONNEL: L. A. Wilkie, Pres.; R. J. Wilkie, V. Pres. & Gen. Mgr.; L. Haling, Treas.; J. W. Wilkie, Prod. Mgr.; L. Rothenberger, Sales Mgr.; W. Hamlett, Pur. Dir.; C. H. Rosene, Adv. Mgr.; J. Harrington, Chief Engr.

**CONTINENTAL SCREW CO.,**

170 Mt. Pleasant St., New Bedford, Mass.  
PERSONNEL: P. Sweeney, Pres. & Gen. Mgr.; D. D. Davis, V. Pres. & Sales Mgr.; C. H. Wardwell, Treas.; M. Hunt, Pur. Dir.; H. Phipard, Adv. Mgr.

**COOK ELECTRIC CO.,**

2700 Southport Ave., Chicago, Ill.  
PERSONNEL: W. C. Hasselhorn, Pres.; J. S. Baker, V. Pres.; C. E. Lundeen, Secy. & Treas.; T. R. Hough, Plant Mgr.; W. A. Ziebell, Pur. Dir.; R. E. Fulton, Pers. Dir.; C. Schliekert, Adv. Mgr.

**COOK HEAT TREATING CORP.,**

3334 E. Slauson Ave., Los Angeles, Calif.  
PERSONNEL: W. W. Farrar, Pres.; R. S. Smith, Secy., Treas. & Gen. Mgr.; W. H. Laury, Pur. Agt.

**COOK PAINT & VARNISH CO.,**

Kansas City, Mo.  
PERSONNEL: C. R. Cook, Pres.; W. H. Hoover, V. Pres. & Sales Mgr.; L. G. Backstrom, Exec. V. Pres.; J. W. Clark, Prod. Mgr.; E. W. Wadlow, Pur. Dir.; D. O'Leary, Pers. Dir.; J. Jones, Pub. Dir. & Adv. Mgr.

**THE COOPER ALLOY FOUNDRY CO.,**

Bloy St. & Ramsey Ave., Hillside, N. J.  
PERSONNEL: H. A. Cooper, Pres.; C. J. Jerntrom, V. Pres.; S. Zolin, Secy., Treas. & Pur. Agt.; J. Victorine, Sales Mgr.

**P. & F. CORBIN, New Britain, Conn.**

PERSONNEL: G. T. Kimball, Pres.; C. B. Parsons, V. Pres. & Gen. Mgr.; G. Hildebrandt, Secy.; W. J. Bunce, Treas.; W. S. Johnson, Sales Mgr.; J. C. Andrews, Pur. Agt.; C. Mortenson, Pers. Dir.; A. J. Sataline, Pub. Dir.; S. P. Morgen, Chief Engr.

**THE CORBIN SCREW CORP.,**

High, Myrtle & Grove Sts., New Britain, Conn.  
PERSONNEL: G. T. Kimball, Pres.; G. Hildebrandt, Secy.; W. J. Bunce, Treas.; J. P. Baldwin, Gen. Mgr.; E. C. Paddock, Sales Mgr.; J. C. Andrews, Pur. Dir.

**CORNELL IRON WORKS, INC.,**

36th Ave. & 13th St., Long Island City, N. Y.  
PERSONNEL: M. L. Cornell, Pres. & Treas.; J. B. Cornell, V. Pres. & Secy.; M. J. Graff, Sales Mgr.; H. Hall, Pur. Agt.; W. Kavanagh, Acting Chief Engr.

**CORNING GLASS WORKS, Corning, N. Y.**

PERSONNEL: G. W. Cole, Pres.; J. L. Peden, V. Pres.; W. H. Curtiss, Secy.; C. D. LaFollette, Treas.; W. A. Kates, Gen. Sales Mgr.; F. D. Conable, Pur. Agt.; J. Palme, Pers. Dir.; A. Vaksdal, Chief Engr.

**COSCO MANUFACTURING CO.,**

832 E. 60th St., Los Angeles, Calif.  
PERSONNEL: P. B. Belding, Pres. & Gen. Mgr.; F. D. Clark, V. Pres.; J. A. Nickum, Treas.; H. L. Sears, Sales Mgr.; O. A. Johnson, Pur. Agt.; L. H. Garey, Chief Engr.



*Delivering!*  
**THE GOODS!**

**C**ONSOLIDATED RADIO PRODUCTS COMPANY is "delivering the goods" to the many theatres of war by the extensive production of many types of headsets and transformers. These headsets and transformers have given praiseworthy performance as fighting tools in communications equipment. Backed by a 12 years' tradition of outstanding accomplishment, Consolidated has every up-to-date facility for engineering and quantity production of these vitally important implements of war.

For better living in the days ahead, Consolidated has included other electro-acoustical devices in their post-war plans as well as the transformers and headsets now meeting the severest demands of service by our U. S. Signal Corps.



*Electronic and Magnetic Devices*  
**CONSOLIDATED RADIO**  
*Products Company*

350 W. ERIE ST., CHICAGO 10, ILL.

**COUSE LABORATORIES,**

300 Passaic St., Newark, N. J.  
PERSONNEL: K. W. Couse, M. Thompson.  
Partners.

**THE COWLES DETERGENT CO.,**

7016 Euclid Ave., Cleveland 3, O.  
PERSONNEL: E. Cowles, Pres.; R. F. Huntley,  
Gen. Mgr.; M. A. Small, Prod. Mgr.; C. C.  
Bassett, Sales Mgr.; W. J. Brooker, Adv. Mgr.

**COWLES TOOL CO.,**

2086 W. 110th St., Cleveland, O.  
PERSONNEL: E. A. Cowles, Pres. & Gen. Mgr.;  
C. W. Sollenberger, Secy. & Pur. Agt.

**COX & STEVENS AIRCRAFT CORP.,**

Glen Cove Rd., Mineola, N. Y.  
PERSONNEL: S. B. Sweeney, Pres.; A. L.  
Thurston, V. Pres. & Chief Engr.; H. E.  
Ackerly, Secy.; R. D. Huntington, Treas.; P.  
Lewis, Pur. Agt.

**RALPH C. COXHEAD CORP.,**

333 Sixth Ave., New York 14, N. Y.  
PERSONNEL: R. C. Coxhead, Pres.; S. P. Cox-  
head, V. Pres. & Treas.; W. Dreichler, Secy.;  
H. C. Mohn, Prod. Mgr.; C. Heppenstall, Sales  
Mgr.; A. Brown, Pur. Dir.; W. R. Brown, Pers.  
Dir.; C. W. Norton, Chief Engr.

**THE R. W. CRAMER CO., INC.,**

Centerbrook, Conn.  
PERSONNEL: R. W. Cramer, Pres.; E. L.  
Schellens, Pur. Dir.

**CRANE PACKING CO.,**

1800 Cuyler Ave., Chicago, Ill.  
PERSONNEL: F. E. Payne, Pres.; A. W. Payne,  
V. Pres.; R. Rapp, Secy.; C. P. Teeple, Gen.  
Mgr.; R. E. Allen, Sales Mgr.; W. L. Woodlock,  
Pur. Agt.; E. A. Stephen, Pers. Dir.; T. Fisher,  
Pub. Dir.; H. W. Gould, Chief Engr.

**THE CRESCENT CO., INC.,**

Corner Front St. & Central Ave., Paw-  
tucket, R. I.  
PERSONNEL: M. C. Sapinsley, Pres. & Gen.  
Mgr.; W. A. Demers, V. Pres. & Factory Mgr.;  
A. R. Dahlstrom, V. Pres. & Prod. Mgr.; J. T.  
Birch, V. Pres. & Sales Mgr.; J. Sanek, Pur.  
Dir.; F. SanSouci, Chief Engr.

**CRESCENT INSULATED WIRE & CABLE  
CO., Trenton 5, N. J.**

PERSONNEL: C. E. Murray, Jr., Pres.; J. C.  
Murray, Jr., V. Pres.; E. L. Robinson, V. Pres.  
& Sales Mgr.; A. H. Battye, Secy. & Pur. Dir.;  
J. C. Murray, Treas. & Gen. Mgr.; A. W.  
Staller, Prod. Mgr.; L. W. Parker, Pers. Dir.;  
R. B. Eldridge, Adv. Mgr.; M. J. Rich, Chief  
Engr.

**CRESCENT TOOL CO., Jamestown, N. Y.**

PERSONNEL: M. L. Peterson, Pres.; C. E.  
Nelson, V. Pres.; C. F. Fallidine, Secy. & Treas.;  
C. R. Swisshelm, Sales Mgr.; L. G. Lynn, Pur.  
Agt.; J. P. Whalen, Pers. Dir.; A. Sheridan,  
Pub. Dir.

**CRESCENT TRUCK CO.,**

Lebanon, Pa.  
PERSONNEL: J. Hunsicker, Pres.; C. D. Eiler,  
Secy., Treas. & Gen. Mgr.; J. G. Krause, Prod.  
Mgr. & Chief Engr.; R. E. Clark, Sales Mgr. &  
Adv. Mgr.; W. C. Will, Pur. Dir.

**CRITERION MACHINE WORKS,**

403 N. Foothill Rd., Beverly Hills, Calif.  
PERSONNEL: H. Brent, M. DeGrace, Partners;  
E. Montgomery, Pur. Dir.; F. Baker, Chief  
Engr.

**CROCKER-WHEELER ELECTRIC MFG  
CO., Ampere, N. J.**

PERSONNEL: E. S. Perot, Pres.; W. A. Zarth,  
V. Pres. & Chief Engr.; C. F. Poirier, V. Pres.  
& Sales Mgr.; E. C. Jones, Secy.; J. M. Mero,  
Treas.; L. D. Van Aken, Gen. Mgr.; K. N.  
St. John, Pur. Agt.; H. W. Branigar, Pers. Dir.;  
J. Jump, Pub. Dir.

**CHAS. E. CROFOOT GEAR CORP.,**

South Easton, Mass.  
PERSONNEL: N. B. Morse, Pres.; G. T. Cottle,  
Treas.; G. R. Holbrook, Pur. Agt.

**CROUSE-HINDS CO.,**

Wolf & Seventh North Sts., Syracuse 1,  
N. Y.  
PERSONNEL: W. L. Hinds, Pres.; H. B. Crouse,  
Jr., V. Pres.; A. F. Hills, V. Pres. & Sales Mgr.;  
J. R. Tuttle, Secy.; W. C. Blanding, Treas.;  
M. D. Low, Pur. Dir.; F. W. Clary, Pub. Dir. &  
Adv. Mgr.; C. H. Bissell, Chief Engr.

**CRUCIBLE STEEL COMPANY OF**

AMERICA, 405 Lexington Ave., New  
York, N. Y.  
PERSONNEL: F. B. Hufnagel, Pres. & Ch.; R. E.  
Christie, Exec. V. Pres.; A. T. Galbraith, V.  
Pres. & Gen. Mgr. of Sales; K. R. Vogel, Secy.;  
F. L. Cooper, Treas.; R. H. Filsinger, Pur. Dir.;  
L. C. Lovejoy, Pers. Dir.; G. Tuthill, Adv.  
Mgr.

**CUNNINGHAM-HALL AIRCRAFT CORP.,**

13 Canal St., Rochester, N. Y.  
PERSONNEL: F. E. Cunningham, Pres., Gen.  
Mgr. & Sales Mgr.; A. J. Cunningham, V. Pres.  
& Pur. Agt.; R. Morgan, Secy.; J. W. Ful-  
reader, Treas.; H. Miller, Pers. Dir.; D. Fer-  
guson, Chief Engr.

**CUNO ENGINEERING CORP.,**

Meriden, Conn.  
PERSONNEL: C. H. Cuno, Pres. & Treas.; S. L.  
Wolfson, V. Pres.; W. N. Guthrie, V. Pres. &  
Gen. Mgr.; W. A. Barnhart, Secy.; C. A. Lind,  
Sales Mgr.; R. A. Clark, Pur. Agt.; C. H.  
Winslow, Pers. Dir.; G. K. Thornton, Pub.  
Dir.; P. E. Ashton, Chief Engr.

**THE CURRAN CORP.,**

6 Pleasant St., Malden, Mass.  
PERSONNEL: A. F. Curran, Pres., Gen. Mgr. &  
Chief Engr.; H. E. Fuller, V. Pres.; R. D.  
Baker, Treas.

**CURTIS LIGHTING, INC.,**

6135 W. 65th St., Chicago, Ill.  
PERSONNEL: D. Curtis, Pres.; M. C. Wilt, V.  
Pres. & Gen. Mgr.; G. T. Morrow, V. Pres.-  
Sales; L. N. West, Secy. & Treas.; R. C. Mason,  
Pur. Agt.; E. J. Wilson, Pub. Dir.; W. V. C.  
Fouls, Chief Engr.

**CURTIS MFG. CO.,**

1905 Kienlen Ave., St. Louis, Mo.  
PERSONNEL: W. C. Hecker, Pres.; F. Acker-  
man, V. Pres.; C. W. Frees, Secy. & Treas.; J.  
D. Lodwick, Sales Mgr.; J. A. A. Hecker, Pur.  
Agt.; W. F. Krenning, Chief Engr.

**CURTIS PNEUMATIC MACHINERY, DIV.**

OF CURTIS MANUFACTURING CO.,  
1905 Kienlen Ave., St. Louis 20, Mo.  
PERSONNEL: W. C. Hecker, Pres.; F. Acker-  
man, V. Pres. & Works Mgr.; C. W. Frees,  
Secy. & Treas.; J. D. Lodwick, Sales Mgr.;  
J. A. A. Hecker, Pur. Dir.; L. C. Blake, Adv.  
Mgr.

*Designers and manufacturers of computing devices,  
navigational instruments and weighing equipment.*

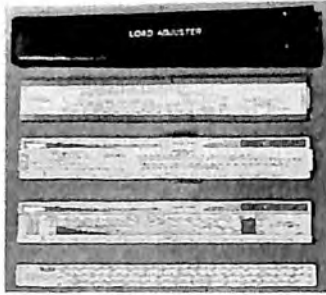

**LOAD ADJUSTER**



**NAVIGATIONAL  
COMPUTER**



**AIRCRAFT ELECTRIC WEIGHING KIT**

**COX & STEVENS AIRCRAFT CORPORATION**

**MINEOLA - LONG ISLAND - NEW YORK - U.S.A.**



**CURTISS-WRIGHT CORP., PROPELLER DIV.,** Caldwell, N. J.

PERSONNEL: G. W. Vaughan, Pres.; R. L. Earle, V. Pres. & Gen. Mgr.; F. Crowe, Asst. Secy.; M. J. Smith, Div. Controller & Asst. Treas.; J. R. Eggert, Prod. Mgr.; W. W. Gleeson, Pur. Agt.; S. S. Tyndall, Pub. Rel. Mgr.; J. M. Hetherington, Ind. Rel. Mgr.; N. A. Kirby, Pers. Mgr.; G. W. Brady, Chief Engr.

**Plants**

Clifton, N. J.; Indianapolis, Ind.; Beaver, Pa.

**CUTLER-HAMMER, INC.,**

315 N. 12th St., Milwaukee, Wisc.

PERSONNEL: F. R. Bacon, Pres.; H. F. Vogt, G. S. Crane, V. Pres.; J. C. Wilson, V. Pres. & Secy.; W. E. Sargent, Treas.; B. M. Horter, Sales Mgr.; F. S. Wilhoit, Pur. Agt.; L. P. Niessen, Adv. Mgr.; P. B. Harwood, Engr. Mgr.

**CYCLONE FENCE DIV., AMERICAN STEEL & WIRE CO.,** P. O. Box 260, Waukegan, Ill.

PERSONNEL: C. F. Hood, Pres.; R. E. Pinniger, V. Pres., Gen. Mgr. & Sales Mgr.; I. E. Bowen, Pur. Agt.; N. S. Harter, Chief Engr.

**THE CYRIL BATH CO.,** E. 70th and Machinery Ave., Cleveland, O.

PERSONNEL: C. J. Bath, Pres.; G. Bath, V. Pres.; R. A. Mackenzie, Secy.; R. Humiston, Treas. & Pur. Agt.; G. E. Atzberger, Sales Mgr.; G. Weimer, Chief Engr.

**D****DAHLSTROM METALLIC DOOR CO.,**

415 Buffalo St., Jamestown, N. Y.

PERSONNEL: P. N. Anderson, Pres. & Gen. Mgr.; C. T. Bergstrom, V. Pres. & Pur. Dir.; G. E. Johnson, Secy. & Treas.; E. S. Ahlstrom, Prod. Mgr.; M. W. Wiesner, Sales Mgr.; F. A. Irvine, Pers. Dir.; H. Nicholson, Pub. Dir. & Adv. Mgr.; C. Thierfeldt, Chief Engr.

**C. R. DANIELS, INC.,**

44 West St., New York 6, N. Y.

PERSONNEL: F. J. Trumbour, Pres.; J. T. Trumbour, V. Pres.; F. C. Spader, Secy.; E. A. Trumbour, Treas.; A. L. Hammond, Gen. Mgr.; J. S. Connelly, Pur. Dir.; W. E. Rainsley, Adv. Mgr.

**DARNELL CORP., LTD.,**

Long Beach, Calif.

PERSONNEL: W. R. Darnell, Pres.; R. W. Longfield, V. Pres.

**DAVIS EMERGENCY EQUIPMENT CO., INC.,** 42 Halleck St., Newark, N. J.

PERSONNEL: F. R. Davis, Pres.; M. D. Smith, Secy.; T. A. Woolsey, Treas.; F. R. Davis, Jr., Sales Mgr.; R. Affleck, Pur. Agt.

**THE DAVISON CHEMICAL CORP.,**

20 Hopkins Place, Baltimore 3, Md.

PERSONNEL: C. F. Hockley, Pres.; W. C. Geoghegan, E. Heubeck, J. N. Mackall & R. L. Hockley, V. Pres.; M. H. McCord, Treas.; M. C. Roop, Secy. & Controller; W. C. Rohde, Pur. Dir.; R. D. Goodall, Mgr. of Silica Gel Sales Prod.; E. B. Bailey, Adv. Mgr.

**DAY-RAY PRODUCTS, INC.,**

912 Fair Oaks Ave., S. Pasadena, Calif.

PERSONNEL: W. A. Munday, Pres., Gen. Mgr. & Pur. Dir.; F. O'Rourke, V. Pres.-Aircraft Contact; R. B. Roney, Secy., Treas., Prod. Mgr. & Chief Engr.; H. B. Johnson, Pers. Dir.

**THE DAYTON MANUFACTURING CO.,**

2240 E. Third St., Dayton, O.

PERSONNEL: H. D. Hendrick, Pres. & Gen. Mgr.; T. R. Sullivan, V. Pres.; E. W. Mink, V. Pres. & Sales Mgr.; H. E. Knoll, V. Pres. & Chief Engr.; N. Jones, Secy. & Pers. Dir.; D. A. Hendrick, Treas.; W. J. Walter, Pur. Agt.

**THE DAYTON RUBBER MFG. CO.,** Dayton, O.

PERSONNEL: A. L. Freedlander, Pres. & Gen. Mgr.; C. E. Hooven, V. Pres. & Secy.; K. H. Glanton, V. Pres.-Mech. Sales; E. A. Baker, Treas.; C. D. Bucher, Pur. Agt.; R. M. Weimer, Pers. Dir.; R. L. Wetzel, Pub. Dir.; N. J. Ritzert, Chief Engr.

**DAYTON TOOL & ENGINEERING CO.,** 730 Lorain Ave., Dayton, O.

PERSONNEL: O. L. Spaeth, Pres. & Treas.; J. K. Matthews, V. Pres.; L. H. Trick, V. Pres. & Chief Engr.; G. W. Houk, Secy. & Gen. Mgr.

**THE DAYTON WHEEL CO.,** Dayton, O.

PERSONNEL: A. N. Wilcox, Pres. & Gen. Mgr.; H. L. Rogge, V. Pres.; J. F. Dobbins, Secy.

**DE JUR-AMSCO CORP.,** Shelton, Conn.

PERSONNEL: R. A. DeJur, Pres.; J. J. Kuschee, V. Pres. & Sales Mgr.; H. DeJur, Secy. & Treas.; P. Bargetzi, Prod. Mgr.; H. J. Lemkin, Pur. Dir.; R. Koller, Pers. Dir.; H. Blye, Chief Engr.; B. G. Scott, Sales Engr.

**THE DE VILBISS CO.,**

300 Phillips Ave., Toledo 1, O.

PERSONNEL: A. D. Gutchess, Pres.; F. A. Bailey, V. Pres. & Gen. Mgr.; H. P. DeVilbiss, V. Pres.-Prod.; R. A. Guyer, V. Pres. & Sales Mgr.; W. W. Conklin, Secy. & Treas.; R. W. Witchner, Pur. Dir.; B. C. Gardner, Adv. Mgr.

**DeYOUNG BROS. MACHINE SHOP,**

8721 Mettler St., Los Angeles, Calif.

PERSONNEL: J. DeYoung, Gen. Mgr.

**THE DEFIANCE STAMPING CO.,**

1941 Perry St., Defiance, O.

PERSONNEL: L. F. Serrick, Pres.; J. G. Murphy, V. Pres.; R. H. Serrick, Secy., Treas. & Gen. Mgr.; L. L. Hendricks, Chief Engr.

**DELCO PRODUCTS DIV., GENERAL MOTORS CORP.,** 329 E. First St., Dayton, O.

PERSONNEL: F. H. Ireland, Gen. Mgr.; R. L. Wilkinson, Sales Mgr.; F. J. O'Donnell, Pur. Agt.; L. W. Lohrey, Pers. Dir.; H. S. Malone, Pub. Dir.; E. F. Rossman, Chief Engr.

**DELCO-REMY DIVISION, GENERAL MOTORS CORP.,** Anderson, Ind.

PERSONNEL: O. V. Badgley, Gen. Mgr.; H. D. Dawson, Prod. Mgr.; A. G. Phelps, Sales Mgr.; H. E. Nye, Pur. Dir.; G. A. Coburn, Pers. Dir.; F. Childers, Adv. Mgr.; R. M. Critchfield, Chief Engr.

**DENHAM & CO.,** Book Bldg., Detroit, Mich.

PERSONNEL: A. M. Gruner, Gen. Mgr.; E. A. Sjogren, Sales Mgr.

**THE DENISON ENGINEERING CO.,**

1160 Dublin Rd., Columbus 16, O.

PERSONNEL: W. C. Denison, Jr., Pres. & Treas.; G. W. Denison, V. Pres.; H. C. Kent, Secy.; F. C. Norris, Gen. Works Mgr.; E. G. Davis, Prod. Mgr.; P. W. Norris, Sales Mgr.; C. W. Ruhl, Pur. Dir.; W. H. Hackett, Pers. Dir.; W. T. Burgess, Adv. Mgr.; V. V. Blasutta, Chief Engr.

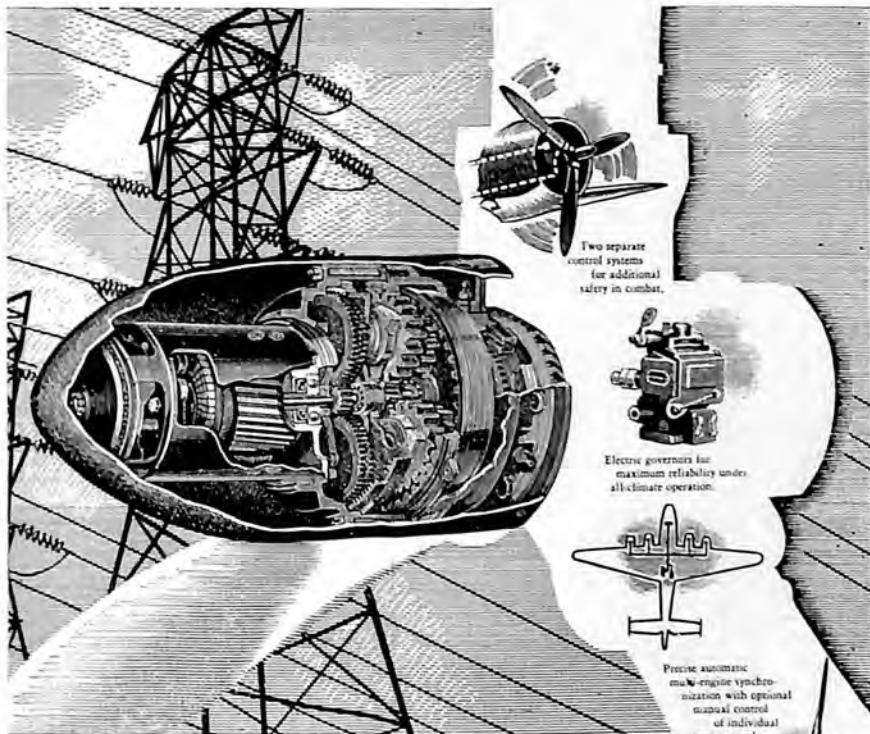

Two separate control systems for additional safety in combat.



Electric governors for maximum reliability under all climate operation.



Precise automatic multi-engine synchronization with optional manual control of individual engine speeds.



Unlimited range of blade angles offers maximum flexibility of control from feathered to reverse positions.

# versatile, reliable - electrical

No other source of power equals electricity in flexibility of application and control. Whether to speed a train or battleship, or to run a simple household appliance, electricity is accepted as a dependable source of energy under all conditions of temperature and climate. In an aircraft propeller, electric control presents a minimum of weight and distance problems, and precise governing and synchronization are readily incorporated. The selection of the electric principle in the original basic propeller design was made with a view to future requirements beyond the needs of simple pitch change. The range of its application continually expands as electric control makes possible new developments in propeller design and operation.

**CURTISS**  
ELECTRIC PROPELLERS

Curtiss-Wright Corporation. Propeller Division



**DESPATCH OVEN CO., 722 Central Ave.**

N. E., Minneapolis, Minn.  
**PERSONNEL:** A. E. Grapp, Pres. & Treas.; H. L. Grapp, V. Pres. & Gen. Mgr.; G. M. Lund, Secy. & Pur. Agt.; F. H. Faber, Sales Mgr. & Pers. Dir.; G. Schuster, S. Trowbridge, Chief Engrs.

**DETREX CORP., 13005 Hillview Ave., Detroit 27, Mich.**

**PERSONNEL:** R. A. Emmett, Pres.; C. F. Dinley, V. Pres.-Research & Mfg.; W. W. Davidson, V. Pres. & Sales Mgr.; A. O. Thalacker, Secy. & Gen. Mgr.; G. E. Powers, Treas.; C. F. Dinley, Jr., Prod. Mgr.; W. G. Smith, Pur. Dir.; E. W. Allison, Pers. Dir.; G. W. Walter, Pub. Dir. & Adv. Mgr.; W. I. Tebo, Chief Engr.

**DETROIT BROACH CO., INC., 20201 Sherwood Ave., Detroit, Mich.**

**PERSONNEL:** G. von Reis, Pres.; C. E. Paulsen, V. Pres.; L. Putnam, Secy.; H. R. Conner, Treas.

**DETROIT GASKET & MFG. CO., 12640 Burt Rd., Detroit, Mich.**

**PERSONNEL:** L. H. Diehl, Pres. & Gen. Mgr.; W. E. Ritter, V. Pres.; E. W. Diehl, Secy. & Treas.; B. S. Brown, Sales Mgr. & Pub. Dir.; C. H. Strauss, Pur. Agt.; H. F. Doolittle, Pers. Dir.; G. T. Balfe, Chief Engr.

**DETROIT REX PRODUCTS CO., 13005 Hillview Ave., Detroit, Mich.**

**PERSONNEL:** R. A. Emmett, Pres.; W. W. Davidson, C. F. Dinley, V. Pres.; A. O. Thalacker, Secy. & Gen. Mgr.; G. E. Powers, Treas.; D. E. Williard, Sales Mgr.; W. G. Smith, Pur. Agt.; G. W. Walter, Pub. Dir.; W. I. Tebo, Chief Engr.

**DETROIT SHEET METAL WORKS, 1307 Oakman Blvd., Detroit 6, Mich.**

**PERSONNEL:** W. V. Baker, Pres.; W. Bush, V. Pres.; C. J. Eberhardt, Secy.; W. Baker, Treas.; R. H. Veitch, Prod. Mgr.; R. W. Wagner, Sales Mgr.; W. Jarvis, Chief Engr.

**DETROIT STAMPING CO., 350 Midland Ave., Detroit 3, Mich.**

**PERSONNEL:** G. H. Roberts, Pres.; J. Beck, V. Pres.; H. G. Roberts, Secy.; J. T. Spencer, Prod. Mgr.; R. Kreger, Chief Engr.

**DETROIT SURFACING MACHINE CO., 7433 W. Davison, Detroit, Mich.**

**PERSONNEL:** F. D. Nunemaker, Pres.; C. W. Evaul, V. Pres.; C. T. Ronan, Secy. & Treas.; F. D. Pease, Chief Engr.

**DIAMOND CHAIN & MFG. CO., 493 Kentucky Ave., Indianapolis, Ind.**

**PERSONNEL:** G. A. Wainwright, Pres. & Gen. Mgr.; C. C. Winegardner, V. Pres. & Pers. Dir.; D. R. Hodges, Secy. & Treas.; W. B. Haislip, Sales Mgr.; C. R. Ramage, Pur. Agt.; H. L. Martin, Pub. Dir.; G. G. Mize, Chief Engr.

**DIBBLE COLOR CO., 1497 E. Grand Blvd., Detroit 11, Mich.**

**PERSONNEL:** R. A. Pulfer, Gen. Mgr.; E. W. Farmer, Asst. Gen. Mgr.

**DIEBOLD, INC., 818 Mulberry Rd., S. E., Canton 2, O.**

**PERSONNEL:** A. J. Roos, Pres. & Gen. Mgr.; G. H. Bockius, V. Pres.; H. C. Weible, Secy. & Treas.; L. H. Clark, Prod. Mgr.; A. E. Frick, Elec. Engr.; H. A. Noble, Sales Mgr.; C. A. Brogden, Pur. Dir.; V. R. Smith, Pers. Dir.; W. K. Wilson, Pub. Dir.; D. W. Cornell, Adv. Mgr.; J. P. Paca, Chief Engr.; A. L. Abbott, Chief Research Engr.

**DIEHL MANUFACTURING CO., Finderne Plant, Somerville, N. J.**

**PERSONNEL:** H. Hertz, Pres.; W. O. Langille, V. Pres.; F. B. Helies, Asst. Secy.; T. W. Paterson, Supt.; W. J. Jockers, Sales Mgr.; L. L. Lund, Pers. Dir.; H. W. Kloth, Adv. Mgr.; P. N. Trickey, Chief Engr.

**DIETZ MANUFACTURING CO., 2310 S. La Cienega Blvd., Los Angeles 34, Calif.**

**PERSONNEL:** R. Dietz, Pres.

**THE DILL MFG. CO., 700 E. 82nd St., Cleveland, O.**

**PERSONNEL:** A. P. Williamson, Pres. & Treas.; E. F. Tobold, V. Pres.; A. E. Bronson, V. Pres. & Secy.; W. C. Holmes, Sales Mgr.; C. W. Bonifield, Pur. Agt.; A. A. Surap, Pub. Dir.; J. C. Crowley, Chief Engr.

**W. C. DILLON & CO., INC., 5410 W. Harrison St., Chicago, Ill.**

**PERSONNEL:** W. C. Dillon, Pres. & Treas.; E. I. Dillon, V. Pres. & Gen. Mgr.; H. Surrey, Secy.; R. R. Dillon, Prod. Mgr. & Chief Engr.; R. E. Dillon, Sales Mgr. & Adv. Mgr.; D. Gramley, Pur. Dir.

**DITTO, INC., 2243 W. Harrison St., Chicago, Ill.**

**PERSONNEL:** T. W. Robinson, Sr., Pres.; T. W. Robinson, Jr., V. Pres.; K. M. Henderson, Secy.; J. J. Williams, Sales Mgr.; F. Gregor, Jr., Pub. Dir.

**DIX MANUFACTURING CO., 3447 East Pico Blvd., Los Angeles 23, Calif.**

**PERSONNEL:** R. W. Adair, Pres., Sales Mgr. & Adv. Mgr.; J. A. Hamilton, Gen. Mgr., Pur. Dir. & Pers. Dir.; A. J. Cogorno, Prod. Mgr.; D. J. Dickerson, Chief Engr.

**DOAK AIRCRAFT CO., INC., 2321 Abalone St., Torrance, Calif.**

**PERSONNEL:** E. R. Doak, Pres. & Gen. Mgr.; N. E. Grace, V. Pres.; R. H. Parkin, Secy. & Treas.; S. F. Hinchliffe, Sales Mgr.; F. M. Behr, Pur. Agt.; D. Blasdel, Pers. Dir. & Pub. Dir.

**DOCKSON CORP., 3839 Wabash Ave., Detroit, Mich.**

**PERSONNEL:** S. H. Dockson, Pres., Sales Mgr., Pub. Dir. & Adv. Mgr.; H. E. Piggott, V. Pres., Prod. Mgr. & Pur. Dir.; P. D. Holmes, Secy., Treas. & Pers. Dir.; C. H. Dockson, Gen. Mgr.; H. Hackman, Chief Engr.

**DODGE CORK CO., INC., Lancaster, Pa.**

**PERSONNEL:** A. B. Dodge, Pres., Treas., Gen. Mgr. & Pur. Agt.; J. F. Cochran, V. Pres.; J. L. Kauffman, Secy.; O. L. Williams, Sales Mgr. & Pub. Dir.; W. R. Edwards, Pers. Dir.; R. K. Dodge, Chief Engr.

**DOEHLER DIE CASTING CO., 386 Fourth Ave., New York, N. Y.**

**PERSONNEL:** C. Pack, Pres.; F. J. Koegler, V. Pres.; F. Knoebel, Secy.; R. Bernhard, Treas.; L. H. Pillion, Sales Mgr.; H. Doehler, Pur. Agt.

**THE DOLE VALVE CO., 1901-1941 Carroll Ave., Chicago 12, Ill.**

**PERSONNEL:** J. L. Dole, Pres. & Gen. Mgr.; T. B. Chace, V. Pres.; A. C. Goodrich, Secy.; S. G. Phillips, Treas. & Adv. Mgr.; J. Butler, Prod. Mgr.; R. Mellis, V. Pres. & Sales Mgr.; L. Jones, Pur. Dir.; B. Weaver, Pers. Dir.; J. Reinhardt, Chief Engr.

# **COOK** Aircraft Accessories

SOLVE MANY ENGINEERING PROBLEMS

Cook Bellows, Cook Pressure Switches and Cook Relays have been the answer to many unusual, almost "impossible" problems. Cook engineers can give you the RIGHT answer QUICKLY.

## *"Spring-life"* METAL BELLOWS



Metallic bellows that withstand 600 million flexures. Bellows from 3/4" O.D. to unlimited diameters and length. Construction that affords a choice of metals

from phosphor bronze, copper, stainless steel, Monel, Inconel, beryllium copper or alloy steel.

## *"Extra-Ordinary"* PRESSURE SWITCHES

Cook's Family of Pressure Detector Switches cover a complete operating range, from extreme sensitivity requirements at 1/4" water column differential to high pressure, hydraulic applications. Illustrated is the new Cook Weather-proof Miniature, for aircraft use.



## *"Aeroelectric"* RELAYS

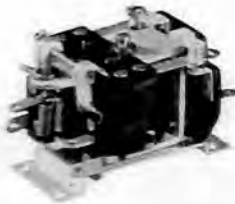

Cook relays are built to do the unusual jobs, and are engineered by request to meet "extra-ordinary" requirements. Not "stock-bin" combinations, but spe-

cially designed to meet specific demands. Illustrated is the new Cook Type 594 "Aeroelectric" Relay.

# COOK ELECTRIC



Specially  
Designed  
Precision Built  
Aeroelectric  
Accessories

## Company

2700 SOUTHPORT AVENUE

CHICAGO 14, ILLINOIS

**DOLLIN CORP.,**

600 S. 21st St., Irvington, N. J.  
 PERSONNEL: E. N. Dollin, Pres.; L. Turner, V. Pres.; J. L. Pinks, Secy.; J. R. Schuchardt, Sales Mgr.; L. Bello, Pur. Agt.; C. Thran, Pers. Dir.; H. L. Muhrer, Chief Engr.

**DOOLITTLE RADIO, INC.,**

7421 S. Loomis Blvd., Chicago, Ill.  
 PERSONNEL: E. M. Doolittle, Pres. & Treas.; D. Gray, V. Pres., Secy. & Chief Engr.; A. Feeley, Secy.; C. M. Rodman, Sales Mgr.; J. Domotor, Pur. Agt.

**H. A. DOUGLAS MFG. CO., Bronson, Mich.**

PERSONNEL: K. Krebsner, V. Pres. & Gen. Mgr.; T. W. Drory, Sales Mgr.; C. J. Scribner, Pur. Agt.; F. Behl, Chief Engr.

**THE DOW CHEMICAL CO., Midland, Mich.**

PERSONNEL: W. H. Dow, Pres. & Gen. Mgr.; L. I. Doan, V. Pres., Secy. & Sales Mgr.; E. W. Bennett, Treas.; L. B. Grant, Mgr., Magnesium Sales; J. E. LeFevre, Pur. Dir.; J. M. Hooker, Adv. Mgr.; L. J. Richards, Chief Engr.

**DRAKE MANUFACTURING CO.,**

1713 W. Hubbard St., Chicago, Ill.  
 PERSONNEL: A. J. Foute, Gen. Mgr.; G. Foute, Prod. Mgr.; H. K. Foute, Sales Engr.

**DRAYER AND HANSON, INC.,**

738 E. Pico Blvd., Los Angeles 21, Calif.  
 PERSONNEL: R. E. Ristow, Pres. & Gen. Mgr.; S. M. Hauser, V. Pres. & Adv. Mgr.; M. J. Burke, Secy.; P. E. Putnam, Asst. Secy.; C. M. Peterson, Prod. Mgr.; J. G. Lombardi, Sales Mgr.; B. K. Taylor, Pur. Dir.; J. J. Emrick, Pers. Dir.; A. Hanson, Chief Engr.

**DRIVER-HARRIS CO., Harrison, N. J.**

PERSONNEL: F. L. Driver, Pres. & Gen. Mgr.; S. M. Tracy, Exec. V. Pres. & Treas.; F. V. Lindsey, V. Pres. & Sales Mgr.; H. D. McKinney, V. Pres. & Works Mgr.; E. A. Harleman, Secy. & Pur. Agt.; G. V. Corbett, Pub. Dir.

**E. I. DU PONT DE NEMOURS & CO., INC., PLASTICS DEPARTMENT, 626 Schuyler Ave., Arlington, N. J.**

PERSONNEL: A. E. Pitcher, Gen. Mgr.; W. A. Joslyn, Sales Dir.; H. J. Barnett, Pur. Agt.; W. Bayne, Pers. Dir.; E. J. Pechin, Adv. Mgr.; A. J. G. Riley, Chief Engr.

**THE DUFF-NORTON MANUFACTURING CO., 2709 Preble Ave., N. S., Pittsburgh, Pa.**

PERSONNEL: R. G. Allen, Pres.; W. I. Floyd, V. Pres. & Treas.; F. O. Graham, Secy.; E. M. Webb, Gen. Mgr.; J. F. Van Nort, Sales Mgr.; A. E. Hurrell, Pur. Agt.; C. H. Gordon, Pers. Dir.; F. H. Schwerin, Chief Engr.

**DUGAS ENGINEERING CORP.,**

Marinette, Wisc.  
 PERSONNEL: H. V. Higley, Pres.; A. A. Michaud, V. Pres., Gen. Mgr. & Sales Mgr.; F. J. Hood, Secy. & Treas.; J. F. Taylor, Pur. Agt.; H. G. Hastert, Chief Engr.

**THE DUMORE CO., Racine, Wisc.**

PERSONNEL: L. H. Hamilton, Pres.; R. L. Hamilton, V. Pres. & Sales Mgr.; J. M. Hamilton, Secy. & Pur. Agt.; H. F. Nehoda, Treas.; G. A. Zimmerman, Gen. Mgr.; P. Wellnitz, Pers. Dir.; R. B. Voelker, Pub. Dir.; H. F. Doll, Chief Engr.

**STRUTHERS DUNN, INC.,**

1321 Arch St., Philadelphia, Pa.  
 PERSONNEL: H. W. Pfeffer, Pres.; J. J. McKiernan, Jr., V. Pres.; M. L. Dunn, Secy. & Treas.; C. F. Schattler, Gen. Mgr.; C. A. Packard, Sales Mgr.; G. M. Herb, Pur. Agt.

**DURA-PRODUCTS MFG. CO.,**

1407-21 Fifth St., S. W., Canton, O.  
 PERSONNEL: C. C. Steiner, Pres.; E. W. George, V. Pres., Secy. & Treas.; L. J. Bitter, Sales Mgr.; R. C. Paul, Pur. Agt.; R. B. Bollman, Pers. Dir.; P. E. Funk, Pub. Dir.; R. B. McKinley, Gen. Supt.

**DURAKOOL, INC.,**

1010 N. Main St., Elkhart, Ind.  
 PERSONNEL: H. E. Bucklen, Jr., Pres.; H. E. Bucklen, III, V. Pres. & Gen. Mgr.; R. Bucklen, Treas.; H. D. Nieman, Sales Mgr.; J. Keoling, Chief Engr.

**DURAL RUBBER CO., Flemington, N. J.**

PERSONNEL: R. J. Heiney, Pres. & Gen. Mgr.; J. J. Davidson, Secy.; J. A. Davidson, Treas. & Sales Mgr.; F. Baumgardner, Pur. Agt.

**DURAMOLD DIV. OF FAIRCHILD ENGRG. & AIRPLANE CORP., 524 W. 52nd St., New York, N. Y.**

PERSONNEL: J. C. Ward, Pres.; A. P. Adams, V. Pres. & Gen. Mgr.; W. Schwebel, Secy.; W. Wilson, Treas.; W. Deeds, Prod. Mgr. & Factory Mgr.; W. Choss, Sales Mgr.; W. Lawrence, Pur. Dir.; R. L. Carter, Pers. Dir.; J. Lowes, Pub. Dir. & Adv. Mgr.; A. W. Hoenke, Chief Engr.

**DUREZ PLASTICS & CHEMICALS, INC.,**

N. Tonawanda, N. Y.  
 PERSONNEL: H. M. Dent, Pres. & Gen. Mgr.; G. E. Becker, V. Pres.; J. F. Snyder, Secy. & Treas.; A. W. Hanmer, Jr., R. E. Dodd, C. T. O'Connor, Sales Mgrs.; C. M. Bell, Pur. Agt.; A. Hein, Pers. Dir.; H. S. Spencer, Pub. Dir.; G. M. Loomis, Chief Engr.

**DURO METAL PRODUCTS CO.,**

2649 N. Kildare Ave., Chicago, Ill.  
 PERSONNEL: W. H. Odlum, Pres.; W. R. Horsford, Sales Mgr.; F. W. Green, Pur. Agt.; L. J. Hansen, Pers. Dir.; C. E. Brady, Pub. Dir.; S. Bishop, Chief Engr.

**DYCER AVIATION SUPPLIES,**

11156 S. Main St., Los Angeles, Calif.  
 PERSONNEL: E. A. Dycer, Owner & Gen. Mgr.; C. A. Emerson, Asst. Sales Mgr.

**DZUS FASTENER CO., INC.,**

Main St., Babylon, N. Y.  
 PERSONNEL: W. Dzus, Pres., Treas. & Gen. Mgr.; F. Wells, V. Pres. & T. Dzus, Secy.; L. F. Acker, Sales Mgr., Pub. Dir. & Adv. Mgr.; G. H. Arnold, Pur. Agt.; C. Pfeifle, Prod. Mgr. & Pers. Dir.; J. Gunther, Chief Engr.

**E****E. A. LABORATORIES, INC.,**

696 Myrtle Ave., Brooklyn 5, N. Y.

**EAGLE PARACHUTE CORP.,**

424 N. Queen St., Lancaster, Pa.  
 PERSONNEL: C. J. Follmer, Pres.; R. E. Knoll, Secy.; J. W. Van Buskirk, Prod. Mgr.

**EASTERN AIR DEVICES, INC.,**

314 Dean St., Brooklyn, N. Y.  
 PERSONNEL: H. G. Hamilton, Pres.; W. Goat, Secy. & Treas.; L. C. Pratt, Chief Engr.

**EASTERN ENGINEERING CO.,**

45 Fox St., New Haven, Conn.

**THE EASTERN MACHINE SCREW CORP.,**

Truman & Barclay Sts., New Haven, Conn.



# DZUS-The Fastener Supreme



*Quarter Turn*

*Self Locking*



Used by the leading manufacturers of military aircraft, tanks, trucks, radios and many other products.

The Dzus Fastener is known throughout the world for its utter simplicity, rapid, positive action, and its absolute dependability.

For the best in fasteners, always specify "Dzus".



**DZUS FASTENER COMPANY**  
INCORPORATED

BABYLON, N. Y.

GLENDAL, CALIF.

**EASTMAN KODAK CO.,** Rochester, N. Y.  
 PERSONNEL: T. J. Hargrave, Pres.; C. E. K. Mees, H. C. Sievers, C. K. Flint, A. Stuber, M. J. Hayes, V. Pres.; A. K. Chapman, V. Pres. & Gen. Mgr.; I. N. Hultman, E. S. Farrow, Asst. V. Pres. & Asst. Gen. Mgr.; J. E. McGhee, Asst. V. Pres. & Gen. Sales Mgr.; M. B. Folsom, Treas.; J. L. Gorham, F. M. Page, A. H. Robinson, Asst. Treas.; M. K. Robinson, Secy.; W. F. Shepard, Asst. Secy.; C. J. Van Niel, Gen. Compt.; I. L. Houley, T. J. McCarrick, Asst. Compts.

**EATON MANUFACTURING CO.,**  
 739 E. 140th St., Cleveland, O.  
 PERSONNEL: C. I. Ochs, Pres.; R. H. Daisley, V. Pres.; H. C. Stuessy, Secy. & Treas.; V. Cada, Pur. Agt.; A. H. Richards, Pers. Dir.; M. Fenley, Pub. Dir.; V. Young, Chief Engr.

**ECLIPSE AIR BRUSH CO., INC.,**  
 386 Park Ave., Newark, N. J.  
 PERSONNEL: H. W. Beach, Pres.; A. H. Downs, Secy.

**ECLIPSE-PIONEER DIV., BENDIX AVIATION CORP.,** Teterboro, N. J.  
 PERSONNEL: K. MacGrath, Gen. Mgr.; C. A. Hinds, Compt.; R. H. Isaacs, Dir.-Sales & Service; W. A. Reichel, Dir. of Engrg.; R. C. Sylvander, Chief Engr.; C. C. Shangraw, Exec. Engr.; F. G. Muller, Pub. Rel. Dir.; A. H. Endlekofer, Factory Mgr.; H. T. Leeming, Supervisor of Pur.

**Eclipse Products:**

PERSONNEL: J. C. Harrower, Sales Mgr.; J. E. Maczko, Adv. Mgr.; D. M. McGrath, Service Mgr.

**Pioneer Products:**

PERSONNEL: G. A. Lewthwaite, Sales Mgr.; D. S. Tilden, Service Mgr.

**EDISON-SPLITDORF CORP.,**  
 West Orange, N. J.  
 PERSONNEL: A. Walsh, Pres.; A. J. Clark, V. Pres., Gen. Mgr. & Sales Mgr.; F. C. Erwin, Secy.; H. H. Eckert, Treas.; G. H. McLaughlin, Pur. Agt.; S. Schaeffer, Pub. Dir.; E. B. Nowosielski, Chief Engr.

**EDO AIRCRAFT CORP.,** College Point, N. Y.  
 PERSONNEL: E. D. Osborn, Pres.; G. B. Post, Sales Mgr. & V. Pres. of Sales & Contracts; W. P. Willetts, Secy.; S. E. Bostwick, Treas.; K. D. Vosler, V. Pres.-Prod.; W. F. Konrad, Pur. Dir.; J. H. Burkett, Pers. Dir.; H. Y. Satterlee, Adv. Mgr.; B. V. Korvink-Kroukovsky, V. Pres.-Engrg.

**THE EDWARDS MANUFACTURING CO.,**  
 Fifth & Butler Sts., Cincinnati, O.  
 PERSONNEL: H. W. Edwards, Pres. & Treas.; G. D. Myers, V. Pres. & Secy.; G. R. Edwards, Supt. & Gen. Mgr.; H. A. Smith, Sales Mgr.; H. Tapke, Pur. Agt.; S. Richmond, Chief Engr.

**EGGELHOF ENGINEERS, 309 Construction Bldg.,** Dallas, Tex.  
 PERSONNEL: H. Eggelhof, Gen. Mgr.

**THE EGYPTIAN LACQUER MFG. CO.,**  
 1270 Sixth Ave., New York, N. Y.  
 PERSONNEL: R. Ruckgarber, Pres.; O. J. S. de Brun, V. Pres. & Secy.; T. Hofacker, Treas.; N. Bolin, Gen. Mgr.; J. G. Malool, Asst. Sales Mgr.; F. J. Burnett, Pur. Agt.; W. E. Hall, Chief Chemist.

**E'COR, INC.,**  
 1501 W. Congress St., Chicago, Ill.  
 PERSONNEL: N. H. Wendell, Jr., Pres.; R. D. Wright, V. Pres.; W. R. Ward, Treas.; N. J. Viere, Sales Mgr.; I. Rud, Pur. Agt.; T. Seny, Pers. Dir.; W. F. Beck, Pub. Dir.; J. Nader, Chief Engr.

**EISEMANN CORP.,**  
 68-34th St., Brooklyn, N. Y.  
 PERSONNEL: J. A. Seubert, Pres.; F. S. Jerome, V. Pres.; S. M. Carvill, Secy.; O. H. Ashman, Treas.; E. B. Van Dyne, Mgr. Mgr.; B. B. Woodford, Sales Mgr.; G. J. Miller, Pur. Agt.; A. E. Weiss, Pers. Dir.; J. M. Hannon, Pub. Dir.; L. H. Scott, Chief Engr.

**EITEL-McCULLOUGH, INC.,**  
 San Bruno, Calif.  
 PERSONNEL: W. W. Eitel, Pres.; J. A. McCullough, V. Pres. & Treas.; W. B. Harrison, Secy.; O. H. Brown, Pur. Agt. & Pers. Dir.

**ELASTIC STOP NUT CORP.,**  
 2330 Vauxhall Rd., Union, N. J.  
 PERSONNEL: W. T. Hedlund, Pres.; W. C. Collins, V. Pres.; W. F. McGuinness, Secy. & Treas.; T. H. Corpe, Sales Mgr.; E. F. Howell, Pur. Agt.; R. O'Brien, Pers. Dir.; W. Reynolds, Pub. Dir.; B. C. Sandemar, Chief Engr.

**THE ELECTRIC AUTO-LITE CO.,**  
 Toledo 1, O.  
 PERSONNEL: R. G. Martin, Pres.; D. H. Kelly, Exec. V. Pres.; W. V. Flook, B. A. Fay, L. H. Middleton, D. B. Stratton, J. P. Falvey, C. W. Pound, J. A. Minch, C. L. Patterson, J. R. Padesky, V. Pres.; P. H. Landwehr, Secy.; J. B. Fenner, Treas.; H. D. Bissell, Adv. Mgr.; E. H. Reed, Dir. of Pur.

**THE ELECTRIC FURNACE CO.,** Salem, O.  
 PERSONNEL: R. F. Benzing, Pres.; C. L. West, V. Pres.; R. D. Painter, Secy.; F. T. Cope, Gen. Mgr.; R. M. Warren, Pur. Agt.; A. E. Wright, Pub. Dir.; A. H. Vaughan, Chief Engr.

**ELECTRIC VACUUM CLEANER CO., INC.,**  
 1734 Ivanhoe Rd., Cleveland, O.  
 PERSONNEL: J. Tuteur, Pres. & Gen. Mgr.; R. B. Wilson, V. Pres. & Sales Mgr.; V. M. Cannon, Secy. & Treas.; R. M. Richmond, Pur. Agt.; E. A. Hamala, Pub. Dir.; H. T. Lang, Chief Engr.

**ELECTROL INC.,**  
 85 Grand St., Kingston, N. Y.

**ELECTROLINE CO.,**  
 4121 S. LaSalle St., Chicago, Ill.  
 PERSONNEL: A. A. Berndt, Pres.; H. S. Sines, V. Pres.; H. C. Nycum, Chief Engr.

**ELECTRONIC LABORATORIES, INC.,**  
 122 W. New York St., Indianapolis, Ind.  
 PERSONNEL: N. R. Kevers, Pres. & Pub. Dir.; W. W. Garstang, V. Pres. & Sales Mgr.; E. A. McAllen, Secy.; T. D. Scheidler, Treas.; W. J. Lochhead, Pur. Agt.; W. P. Hahn, Pers. Dir.; M. R. Krasno, Chief Engr.

**ELECTRONIC SPECIALTY CO.,**  
 3456 Glendale Blvd., Los Angeles, Calif.  
 PERSONNEL: D. A. Marcus, Gen. Mgr.; S. K. Babcock, Chief Engr.

**THE ELWELL-PARKER ELECTRIC CO.,**  
 4205 St. Clair Ave., Cleveland, O.  
 PERSONNEL: S. K. Towson, Pres. & Gen. Mgr.; W. A. Meddick, V. Pres. & Sales Mgr.; W. Stage, Secy.; W. E. Hornig, Treas.; W. F. Avery, Pur. Agt.; S. Kiser, Pers. Dir.; C. B. Cook, Pub. Dir.; C. E. Cochran, Chief Engr.

**ENDICOTT FORGING & MFG. CO., INC.,**  
 1923 North St., Endicott, N. Y.  
 PERSONNEL: A. L. Kent, Pres.; A. W. Schaefer, Secy. & Sales Mgr.; C. A. Murray, Treas. & Pur. Agt.

**ENGL AIRCRAFT SPECIALTIES,**  
 Box 697, Escondido, Calif.  
 PERSONNEL: T. H. Engel, Gen. Mgr.



# EXTRUDED PLASTICS FOR THE



## AIRCRAFT INDUSTRY

Specializing in plastics extrusions—both stock shapes and sizes, and custom-made—for aircraft insulation, tubing and structural uses.



- FLEXIBLE PLASTIC TUBING with excellent electrical insulation properties, water resistant, gas resistant, oil resistant, remains flexible from  $-70^{\circ}$  to  $+170^{\circ}$  F. This material used extensively by leading manufacturers in all types of aircraft—offers great post-war possibilities.



- RODS in diameters from .010" to 4.0" in a complete range of flexibility from elastomers to rigid plastics. A number of aircraft applications have proved their value in actual use.



- CUSTOM SHAPES — we specialize in engineering profiles in all degrees of complexity to meet individual requirements. We make special profiles for many aircraft manufacturers, from their own blueprints and to their own tolerances. Produced in both transparent and opaque materials with a wide range of flexibility and with desired physical, chemical and electrical properties "built in".



N.B. We also do injection molding of all thermoplastics.



ORIGINATORS OF DRY PROCESS PLASTIC EXTRUSION



**CHARLES ENGELHARD, INC.,**

90 Chestnut St., Newark, N. J.  
 PERSONNEL: C. Engelhard, Pres., Treas. & Gen. Mgr.; C. B. Mitchell, V. Pres.; J. H. Laub, Secy.; A. W. Taber, Sales Mgr.; W. O. Kunze, Pur. Agt.; T. Koehn, Pers. Dir.; J. Kremer, Chief Engr.

**ENGINEERING & RESEARCH CORP.,**

Riverdale, Md.  
 PERSONNEL: L. A. Wells, Pres.; M. W. King, V. Pres. & Secy.; W. G. Carroll, Treas.; J. N. Dean, Gen. Mgr.; E. P. Scully, Pur. Agt.; J. E. Richardson, Pers. Dir.; P. C. Wright, Pub. Dir.; F. E. Weick, Chief Engr.

**ENGIS EQUIPMENT CO.,**

310 S. Michigan Ave., Chicago, Ill.  
 PERSONNEL: J. P. Steindler, Pres.; E. J. Schneider, V. Pres. & Secy.; M. Steindler, Treas.

**ERIE RESISTOR CORP.,**

640 W. 12th St., Erie, Pa.  
 PERSONNEL: G. R. Fryling, Pres.; W. H. Fryling, V. Pres. & Sales Mgr.; J. E. Dietsman, Secy., Treas. & Pur. Agt.; F. Gallagher, Pers. Dir.; A. K. Shenk, Pub. Dir.; B. B. Minnium, Chief Engr.

**ERTEL MACHINE CO., Indianapolis, Ind.**

PERSONNEL: J. C. Ertel, Pres.; C. B. Enochs, Gen. Mgr.; J. C. Ertel III, Sales Mgr.

**ESSICK MANUFACTURING CO.,**

1950 Santa Fe Ave., Los Angeles, Calif.  
 PERSONNEL: B. Essick, Gen. Mgr.

**THE ESTERLINE-ANGUS CO., INC.,**

P. O. Box 596, Indianapolis, Ind.  
 PERSONNEL: D. J. Angus, Pres.; A. J. Weber, V. Pres. & Gen. Mgr.; J. T. Casebourne, Secy. & Pur. Agt.; R. J. Kryter, Treas. & Sales Mgr.

**EX-CELL-O CORP.,**

1200 Oakman Blvd., Detroit, Mich.  
 PERSONNEL: P. Huber, Pres. & Gen. Mgr.; T. M. Olson, V. Pres. & Sales Mgr.; J. K. Fulks, V. Pres.-Mfg.; H. G. Bixby, Secy. & Treas.; F. D. Sicklesteel, Pur. Agt.; F. Boucher, Sr., Pers. Dir.; H. L. J. Humphrey, Pub. Dir.; G. D. Stewart, Chief Engr.

**THE EXACT WEIGHT SCALE CO.,**

944 W. Fifth Ave., Columbus 8, O.  
 PERSONNEL: C. J. Kurtz, Pres.; K. B. Neff, V. Pres. & Treas.; S. L. Briggs, Secy.; W. A. Scheurer, Sales Mgr.; T. Hamilton, Pur. Agt.; J. W. Sieverling, Adv. Mgr.; T. B. Flanagan, Chief Engr.

**F****F & H MANUFACTURING CO.,**

10338 Gratiot Ave., Detroit 13, Mich.  
 PERSONNEL: F. Horawa, Pres.

**THE FAFNIR BEARING CO.,**

Booth St., New Britain, Conn.  
 PERSONNEL: M. Stanley, Pres.; S. M. Cooper, Secy.; A. G. Way, Treas.; R. R. Searles, Gen. Mgr.; T. J. Leonard, Prod. Mgr.; C. F. Stanley, Sales Mgr.; H. P. Knowles, Pur. Dir.; G. J. Ely, Pers. Dir.; P. F. Bannister, Adv. Mgr.; H. R. Reynolds, Chief Engr.

**FAHLN MANUFACTURING CO.,**

1121-23 Wilkes Blvd., Columbia, Mo.  
 PERSONNEL: O. Fahlin, Pres.; J. M. Allton, V. Pres.; H. Banks, Secy.; A. T. Driscoll, Gen. Mgr.

**FAIRBANKS, MORSE & CO.,**

600 S. Michigan Ave., Chicago, Ill.  
 PERSONNEL: R. H. Morse, Pres.; A. C. Dodge, A. E. Ashcraft, V. Pres.; S. T. Kiddoo, V. Pres. & Treas.; F. C. Dierks, Secy.; F. J. Heaslip, Pur. Agt.

**FAIRCHILD AVIATION CORP.,**

88-06 Van Wyck Blvd., Jamaica, N. Y.  
 PERSONNEL: J. S. Orsbury, Pres.; E. Robinson, Exec. V. Pres.; C. A. Harrison, V. Pres. & Sales Mgr.; C. L. Terrill, Secy.; J. A. Hewlett, Treas.; R. A. Draghi, Works Mgr.; J. E. Kaiser, Pur. Agt.; R. W. Brown, Pers. Dir.; H. K. Yulke, Pub. Dir.; G. Rattray, Chief Engr.

**FARNHAM MANUFACTURING CO.,**

1646-1654 Seneca St., Buffalo, N. Y.  
 PERSONNEL: F. L. Boutet, Pres. & Treas.; A. E. Farnham, V. Pres.; E. L. Keenan, Secy.; E. M. Finnegan, Pur. Agt.; P. Duboscq, Chief Engr.

**FARREL-BIRMINGHAM CO., INC.,**

Ansonia, Conn.  
 PERSONNEL: J. W. Haddock, Pres.; A. G. Kessler, V. Pres. & Gen. Works Mgr.; A. Kuhns, V. Pres. & Consulting Engr.; C. Hitchcock, V. Pres. & Gen. Sales Mgr.; R. A. North, V. Pres. & Chief Engr.; W. B. Marvin, Secy.; F. M. Drew, Jr., Treas.; C. E. Burton, Gen. Pur. Agt.; A. W. Hendrickson, Dir. of Employee Serv.; T. V. Busk, Adv. Mgr.

**FEDERAL A. C. SWITCH CORP.,**

1200 Niagara St., Buffalo, N. Y.  
 PERSONNEL: H. Henry, Pres. & Gen. Mgr.; N. C. Knapp, Secy.

**FEDERAL AIRCRAFT WORKS, 3456 N.**

Mississippi Dr., Minneapolis 12, Minn.  
 PERSONNEL: F. J. Ditter, Pres., Gen. Mgr., Prod. Mgr. & Pers. Dir.; A. A. Bursch, Sales Mgr., Pur. Dir., Pub. Dir. & Adv. Mgr.; E. J. Boucher, Chief Engr.

**FEDERAL LABORATORIES, INC.,**

185 41st St., Pittsburgh, Pa.  
 PERSONNEL: R. B. Reynolds, Pres., Gen. Mgr. & Chief Engr.; B. H. Barker, V. Pres. & Sales Mgr.; H. E. Rau, Secy. & Treas.; J. Brandt, Pur. Agt.

**FEDERAL MACHINE & WELDER CO.**

Warren, O.  
 PERSONNEL: M. S. Clark, Pres. & Gen. Mgr.; T. E. Jones, V. Pres.; E. W. Clucas, Secy.; P. B. Cridge, Treas.; O. L. Jacobs, Pur. Agt.; C. W. Middlestead, Chief Engr.

**FEDERAL METAL HOSE CORP.,**

277 Military Rd., Buffalo, N. Y.  
 PERSONNEL: H. C. Neff, Pres. & Sales Mgr.

**FEDERAL-MOGUL CORP., Shoemaker &**

Lillibridge Sts., Detroit, Mich.  
 PERSONNEL: H. G. Muzzy, Pres.; D. W. Rodger, V. Pres. & Secy.; S. C. Reynolds, V. Pres. & Treas.; E. O. Jones, Sales Mgr.; E. F. Bauman, Pur. Agt.; D. A. Reid, Pers. Dir.; T. J. Marshall, Pub. Dir.; H. F. Dixon, Chief Engr.

**FEDERAL PRODUCTS CORP.,**

1144 Eddy St., Providence 1, R. I.  
 PERSONNEL: L. C. Tingley, Pres.; F. C. Tanner, V. Pres. & Gen. Mgr.; L. B. Colt, V. Pres.-Sales; S. B. Reynolds, Secy.; C. N. Kingsford, Treas.; I. A. Hunt, Sales Prod. Mgr. & Adv. Mgr.; J. G. Gunderson, Pur. Agt.; V. McKivergan, Pers. Dir.; H. F. Joslin, Supt.

**FEDERAL TELEPHONE & RADIO CORP.,**

P. O. Box 690, Newark 1, N. J.

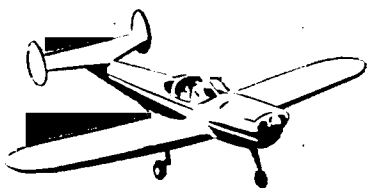

The **ERCOUPE**

Spinproof

Ease and Simplicity of Operation  
Better Performance with Safety



**MACHINERY  
RADAR ANTENNAE  
AIRCRAFT GUN TURRETS**

Part of the War Job done by

**ERCO**

*Manufacturers of the following for aircraft production*

- AUTOMATIC PUNCHING & RIVETING MACHINES
- SHEET METAL FORMERS
- HYDRAULIC STRETCHING PRESSES
- SHEET METAL SHRINKERS
- PROPELLER PROFILING MACHINES



**Engineering & Research Corporation**

Riverdale, Maryland  
Mail: P. O. Box 209  
Hyattsville, Maryland



**THE FELLOWS GEAR SHAPER CO.,**

78 River St., Springfield, Vt.  
 PERSONNEL: E. R. Fellows, Pres.; E. J. Fullam, V. Pres.; R. M. Fellows, Secy. & Treas.; E. W. Miller, Gen. Mgr. & Chief Engr.; M. J. Armstrong, Prod. Mgr.; C. M. Peter, Sales Mgr.; J. M. Rafford, Pur. Dir.; P. Rasmussem, Pers. Dir.; D. T. Hamilton, Pub. Dir. & Adv. Mgr.

**FELT PRODUCTS MFG. CO.,**

1504 Carroll Ave., Chicago, Ill.  
 PERSONNEL: A. Mecklenburger, Pres.; C. A. Stroh, Sales Mgr.

**THE FELTERS CO.,**

210 South Street, Boston 11, Mass.  
 PERSONNEL: L. H. Hansel, Pres.; W. C. King, V. Pres., Secy., Sales Mgr. & Adv. Mgr.; E. M. Guillaume, V. Pres. & Treas.; G. H. Wood, V. Pres. & Prod. Mgr.; C. V. S. Purdy, Pur. Dir.; E. C. Lassey, Pers. Dir.

**FENWAL, INC.,**

Ashland, Mass.  
 PERSONNEL: C. W. Walter, Pres.; W. J. Turenne, V. Pres.

**FERRACUTE MACHINE CO.,**

Bridgeton, N. J.  
 PERSONNEL: G. E. Bass, Pres.; H. Janvier, V. Pres.; P. Meyers, Secy.; L. Meyers, Treas., Gen. Mgr. & Chief Engr.; C. M. Hobson, Jr., Sales Engr.; G. Smith, Pur. Agt.; A. T. Bayley, Pers. Dir.

**FIBRE CONDUIT CO.,**

Orangeburg, N. Y.  
 PERSONNEL: H. J. Robertson, Jr., Pres.; J. R. Connell, V. Pres. & Sales Mgr.; F. G. Wehman, Secy. & Treas.; G. Allen, Pur. Agt.; B. G. LeMieux, Chief Engr.

**FIRESTONE AIRCRAFT CO.,**

Firestone Parkway, Akron, O.  
 PERSONNEL: H. S. Firestone, Jr., Pres.; J. L. Cohill, V. Pres.; W. Shaw, Sales Mgr.

**FIRST AID SUPPLY CO.,**

32 W. 22nd St., New York, N. Y.  
 PERSONNEL: J. Maslan, Pres.; R. Rudin, Secy.; G. Wishny, Gen. Mgr.; P. Baer, Chief Engr.

**FIRTH-STERLING STEEL CO.,**

McKeesport, Pa.  
 PERSONNEL: L. G. Firth, Pres. & Gen. Mgr.; D. G. Clark, V. Pres.; C. G. Krapf, Secy.; H. R. Huemme, Treas.; A. B. Corbin, Sales Mgr.; H. K. Stern, Pur. Agt.; W. F. Rechter, Pers. Dir.; C. F. Hoffman, Pub. Dir.; M. F. Judkins, Chief Engr. Firthite Div.

**FISCHER INDUSTRIES, INC.,**

Paddock Rd. & B & O R. R., Cincinnati, Ohio  
 PERSONNEL: H. Fischer, Pres., Sales Mgr., Pers. Dir. & Adv. Mgr.; H. D. Fischer, V. Pres. & Pur. Dir.; E. B. Fischer, Secy. & Treas.; J. Robert, Gen. Mgr. & Prod. Mgr.; W. Culp, Chief Engr.

**FISCHER SPECIAL MFG. CO.,**

446 Morgan St., Cincinnati, O.  
 PERSONNEL: F. H. Fischer, H. F. Fischer, Partners; C. H. Gross, Sales Mgr.; F. Wehking, Pur. Agt.

**FISCHER'S SURFA-SAVER, INC.,**

Paddock Rd., & B & O R. R., Cincinnati, O.  
 PERSONNEL: H. Fischer, Pres. & Gen. Mgr.; H. D. Fischer, V. Pres.; E. B. Fischer, Secy. & Treas.

**FISHER FURNACE CO.,**

5535 N. Wolcott Ave., Chicago, Ill.  
 PERSONNEL: W. P. Martin, Jr., Pres. & Treas.; K. D. Hoke, V. Pres. & Gen. Mgr.; E. Pankratze, Secy. & Pur. Agt.; P. J. Myall, Sales Mgr.; B. Bell, Chief Engr.

**FISHER RESEARCH LABORATORY,**

1961 University Ave., P. O. Box 356, Palo Alto, Calif.  
 PERSONNEL: G. R. Fisher, Owner; T. Brown, Treas.; C. Fisher, Gen. Mgr.; R. Adams, Sales Mgr.; O. M. McCoy, Pur. Agt.; C. Soderquist, Chief Engr.

**FITCHBURG GRINDING MACHINE CORP.,**

Falulah Rd., Fitchburg, Mass.  
 PERSONNEL: G. S. Gould, Pres., Gen. Mgr. & Adv. Mgr.; J. Cushing, V. Pres. & Sales Mgr.; M. A. Coolidge, Treas.; E. N. Daulton, Prod. Mgr.; J. J. Healey, Pur. Dir.; E. A. Haapanen, Chief Engr.

**GEORGE J. FIX CO.,**

2413 Commerce St., Dallas, Tex.  
 PERSONNEL: G. J. Fix, Sr., Pres. & Gen. Mgr.; L. M. Dorman, Sales Mgr.; G. J. Fix, Jr., Chief Engr.

**FLEETWINGS DIVISION OF KAISER CARGO, INC.,****THE FLEX-O-TUBE CO.,**

14th at Lafayette, Detroit, Mich.  
 PERSONNEL: J. L. Ward, Pres. & Sales Mgr.; R. DeTamble, V. Pres. & Gen. Mgr.; J. H. Conn, Secy., Treas. & Pers. Dir.; G. J. Montith, Prod. Mgr.; A. J. Wyka, Pur. Dir.; N. M. Couty, Chief Engr.

**FLOTATION SYSTEMS, INC.,**

4031 Goodwin Ave., Los Angeles, Calif.  
 PERSONNEL: J. Q. Henry, Pres.; F. E. Kalte, V. Pres. & Pers. Dir.; H. D. Dargert, Secy. & Treas.; L. E. Sowden, Pur. Agt.; T. Gregory, Chief Engr.

**THE FOLMER GRAFLEX CORP.,**

154 Clarissa St., Rochester 8, N. Y.  
 PERSONNEL: N. L. Whitaker, Pres. & Gen. Mgr.; G. C. Whitaker, Vice Pres.; C. H. Harper, V. Pres. & Treas.; H. A. Schumacher, V. Pres. & Sales Mgr.; J. E. B. Murphy, Secy.; C. H. Roth, Sr., Prod. Mgr.; C. J. Krembel, Pur. Dir.; W. Hanna, Employment Mgr.; J. B. Gibson, Dir. Pub. Rel.; R. E. Robischon, Adv. Mgr.; O. Steiner, Chief Engr.

**FOOTE BROS. GEAR & MACHINE CORP.,**

5225 S. Western Blvd., Chicago, Ill.  
 PERSONNEL: W. A. Barr, Pres. & Gen. Mgr.; A. Mackmann, V. Pres.; J. R. Fagan, Secy. & Treas.; R. G. Davis, V. Pres. & Gen. Mgr.-Ind. Gear Div.

**THE FOOTE-BURT CO.,**

Cleveland, O.  
 PERSONNEL: T. H. Doan, Pres.; W. F. Babcock, V. Pres.; S. E. Gross, Secy. & Treas.; W. G. Winship, Pur. Agt.; M. C. Wickham, Pub. Dir.

**THE J. B. FORD SALES CO.,**

Biddle Ave., Wyandotte, Mich.  
 PERSONNEL: C. B. Robinson, Pres. & Gen. Mgr.; W. F. Torrey, V. Pres.; W. M. Cole, Sales Mgr.

**FOREDOM ELECTRIC CO.,**

27 Park Pl., New York 7, N. Y.  
 PERSONNEL: M. F. Sticht, Gen. Mgr.; F. A. Juliano, Prod. Mgr.

**THE FORMICA INSULATION CO.,**

4614 Spring Grove Avenue, Cincinnati 32, O.  
 PERSONNEL: D. J. O'Connor, Pres. & Gen. Mgr.; W. J. Gebhart, V. Pres. & Treas.; E. G. Williams, V. Pres. & Prod. Mgr.; G. Clark, V. Pres. & Chief Engr.; W. Kruse, Secy.; J. R. White, Sales Mgr., Pub. Dir. & Adv. Mgr.; H. Heitbrink, Pur. Dir.; W. Fentress, Pers. Dir.

**THE LIGHT MATERIAL**  
**THAT *Stays Put!***



In hundreds of aviation applications Formica is used because it is a light material (specific gravity 1.35 or half the weight of aluminum); because it holds its dimensions under either varying humidity or varying temperature. It is chemically inert, does not corrode, maintains a smooth surface indefinitely.

You will find it in America's leading planes used for control pulleys, fair leads, propeller parts, air frame parts, electrical insulation in the communications and ignition and lighting circuits, instrument panels, instruction plates, and for such parts as ammunition chutes where it takes the place of sheet metal.

Its use steadily increases, as more and more ways are found to adapt its fundamental characteristics to plane construction.

We are glad to send detailed engineering data on request.

**THE FORMICA  
 INSULATION COMPANY**  
 4677 Spring Grove Avenue  
 Cincinnati 32, Ohio



**FORSYTH METAL GOODS CO.,**

129 Elm St., East Aurora, N. Y.  
PERSONNEL: W. H. Blake, Pres.; G. E. Blake, Treas.

**THE FOSTORIA PRESSED STEEL CORP.,**  
Fostoria, Ohio

PERSONNEL: R. J. Carter, Pres., Treas. & Gen. Mgr.; E. L. Bates, V. Pres. & Prod. Mgr.; C. W. McDaniel, V. Pres., Secy. & Sales Mgr.; R. L. Hill, Pur. Dir.; D. R. Churchman, Pers. Dir.; P. H. Krupp, Pub. Dir. & Adv. Mgr.; J. R. Pigman, Chief Engr.

**THE FOUR WHEEL DRIVE AUTO CO.,**  
Clintonville, Wisc.

PERSONNEL: W. A. Olen, Pres. & Gen. Mgr.; J. D. Cotton, V. Pres.; S. H. Sanford, Secy.; D. J. Rohrer, Treas.; R. H. Schmidt, Sales Mgr.; L. Pinkowsky, Pur. Agt.; F. Dana, Pers. Dir.; F. M. Higgins, Pub. Dir.; H. B. Dodge, Chief Engr.

**FOWLER AIRCRAFT CO.,**

4642 Cass Blvd., San Diego, Calif.

PERSONNEL: H. D. Fowler, Owner; Mrs. H. D. Fowler, Treas.; S. Kousens, Supt.; J. Fischer, Pur. Agt.

**FOX CO., Fox Bldg., Fox Lane & Beekman St.,**  
Cincinnati, O.

PERSONNEL: L. J. Fox, M. G. Fox, Partners.

**S. G. FRANTZ CO., INC.,**

161 Grand St., New York, N. Y.

PERSONNEL: S. G. Frantz, Pres. & Treas.; F. H. Boyd, V. Pres. & Sales Mgr.; G. E. Gibson, Secy.

**FRAY MACHINE TOOL CO.,**

515 W. Windsor Rd., Glendale, Calif.

PERSONNEL: J. H. Richards, Pres. & Gen. Mgr.; L. Hales, V. Pres.; O. W. Weyman, Secy. & Treas.; R. W. Wollard, Pur. Agt.; F. Pollon, Chief Engr.

**FRAZAR & CO., LTD.,**

301 Clay St., San Francisco, Calif.

PERSONNEL: E. W. Frazar, Pres.; O. C. Hansen, V. Pres.; B. Hassler, Sales Mgr.

**FREEDMAN BURNHAM ENGINEERING CORP.,** 659 E. Sixth St., Cincinnati, O.

PERSONNEL: G. L. Freedman, Pres.; B. M. Wallenstein, V. Pres. & Pur. Agt.; W. E. Burnham, V. Pres. & Chief Engr.; S. S. Freedman, Secy. & Treas.

**FRIEZ INSTRUMENT, DIV. OF BENDIX AVIATION CORP.,** Taylor Ave., Towson, Baltimore 4, Md.

PERSONNEL: B. A. Best, Asst. Secy.; A. C. De Angelis, Gen. Mgr.; D. P. Schrier, Factory Mgr.; R. B. Stevenson, Sales Mgr.; T. Centracchio, Pur. Dir.; E. P. Loppacker, Pers. Dir.; V. D. Hauck, Chief Engr.

**FRONTIER BRONZE CORP.,**

4870 Packard Rd., Niagara Falls, N. Y.

PERSONNEL: E. H. Holzworth, Pres.; J. M. Brown, Prod. Mgr.; W. J. Boyle, Sales Mgr.; H. D. Kennedy, Pur. Dir.; H. Brown, Metallurgist.

**FUEL INJECTION CORP.,**

1032 Peck St., Muskegon Heights, Mich.

PERSONNEL: L. Wegusen, Pres.; C. F. High, V. Pres., Sales Mgr. & Chief Engr.; G. L. Lundborg, Secy.

**W. P. FULLER & CO.,** 135 N. Los Angeles St., Los Angeles, Calif.

PERSONNEL: H. B. Wilson, Gen. Mgr.; M. G. McKinlay, Sales Mgr.; H. L. Acker, Chief Engr.

**THE FULTON SYLPHON CO.,**

Knoxville 4, Tenn.

PERSONNEL: J. V. Giesler, Pres.; W. L. Chandler, V. Pres. & Chief Engr.; C. N. Mynderse, V. Pres. & Gen. Mgr.; F. G. Cross, V. Pres. & Sales Mgr.; W. S. D. Woods, Secy.; R. S. Reynolds, Sr., Treas.; F. K. Fulton, Prod. Mgr.; E. C. Silver, Pur. Dir.; W. S. Fowler, Pers. Dir.; E. D. Rogers, Adv. Mgr.

**THE FYR-FYTER CO.,**

221 Crane St., Dayton 1, O.

PERSONNEL: R. C. Iddings, Pres. & Gen. Mgr.; G. Peffer, V. Pres.; A. S. Iddings, Secy. & Treas.; H. Williams, Prod. Mgr.; R. C. Hahn, Sales Mgr. & Adv. Mgr.; R. F. Theis, Pur. Dir.; D. Wood, Pers. Dir.; W. E. Hunt, Pub. Dir.; J. Wright, Chief Engr.

## G

**G & H TOOL AND MANUFACTURING CO.,**

626-28 E. Douglas Ave., Wichita, Kans.

PERSONNEL: O. V. Garrison, P. L. Hatfield, Partners; G. E. McMahan, Pers. Dir.; D. Armstrong, Chief Engr.

**THE G & O MANUFACTURING CO.,**

138 Winchester Ave., New Haven 8, Conn.

PERSONNEL: A. J. Verdi, Pres.; V. Carangelo, V. Pres.; F. I. Newton, Secy.; C. Opppe, Treas. & Gen. Mgr.; C. C. Schott, Prod. Mgr.; M. Wellman, Pur. Dir.; J. J. Sanso, Chief Engr.

**THE GABRIEL CO.,**

1407 E. 40th St., Cleveland, O.

PERSONNEL: J. H. Briggs, Pres. & Gen. Mgr.; L. W. Klein, V. Pres., Sales Mgr. & Pub. Dir.; C. R. Wefler, Secy. & Treas.; G. E. McAllister, Pur. Agt.; C. B. Kurtz, Jr., Pers. Dir.; E. L. Beecher, Chief Engr.

**THE GAERTNER SCIENTIFIC CORP.,**

1201 Wrightwood Ave., Chicago, Ill.

PERSONNEL: W. Gaertner, Pres., Treas., Gen. Mgr. & Sales Mgr.; S. Jacobsohn, V. Pres.; J. Mandel, Secy.; V. DeCancq, Pur. Agt.; L. W. Higgins, Pub. Dir.; P. F. Meyn, Chief Engr.

**GALENA OIL CORP.,**

440 Culvert St., Cincinnati, O.

PERSONNEL: H. M. Hart, Pres.; B. H. Morris, V. Pres.; E. H. Shepherd, Pur. Agt.; G. L. Service, Pub. Dir.; L. A. Calkins, Chief Engr.

**GARDNER-DENVER CO., Quincy, Ill.**

PERSONNEL: H. G. Myers, Pres. & Gen. Mgr.; E. F. Schaefer, V. Pres.; G. H. Gubbins, Secy.; L. H. Stout, Treas.; R. J. MacFarland, Sales Mgr. & Chief Engr.; E. J. Maloney, Pur. Agt.; B. B. Gooch, Pers. Dir.; B. P. Spann, Pub. Dir.

**GARDNER MACHINE CO.,**

Beloit, Wisc.

PERSONNEL: W. B. Leishman, Pres. & Sales Mgr.; I. R. Shue, V. Pres.; C. W. Thompson, Secy.; H. B. Nielsen, Adv. Mgr.

**GARDNER PROPELLER CO.,**

215 Harlem Ave., Forest Park, Ill.

PERSONNEL: W. H. Gardner, Chief Engr.

**THE GARLOCK PACKING CO.,**

Palmyra, N. Y.

PERSONNEL: G. L. Abbott, Pres. & Treas.; C. R. Hubbard, V. Pres.-Prod.; P. Arnold, V. Pres.-Sales; R. M. Waples, Secy.; G. L. Abbott, Treas.; G. W. Cadwallader, Pur. Dir.; E. K. Harter, Pers. Dir.; R. J. Hinkle, Adv. Mgr.; J. B. McClain, Chief Engr.



**PRACTICAL DATA FOR PRESENT PROBLEMS**

Here are two books designed to help users of Molybdenum steels and irons to conserve all alloying elements, and possibly steel and iron, by getting the most in the way of strength, toughness and wear resistance with the lowest alloy content.

"MOLYBDENUM IN STEEL" covers the fundamental metallurgy of Molybdenum steels. Heat treatment

—physical properties—applications—of a number of these steels are treated at length.

"MOLYBDENUM IN CAST IRON" covers the effect of Molybdenum in gray iron, giving suggested analyses for practical applications and detailed discussion of high strength (60,000 p.s.i. and up) irons.

Both books will gladly be sent without charge on request.

**Climax Molybdenum Company**  
**500 Fifth Avenue • New York City**



**GARRISON MACHINE WORKS, INC.,**

9 Emily St., Dayton 7, O.  
PERSONNEL: J. R. Garrison, Pres.; R. P. Garrison, V. Pres.

**THE GASKET MANUFACTURING CO.,**

324 Venice Blvd., Los Angeles, Calif.  
PERSONNEL: L. B. Van De Car, Gen. Mgr.; E. A. Kellenberger, Sales Mgr.

**L. M. GEAR CO.,**

23120 Gratiot Ave., E. Detroit, Mich.  
PERSONNEL: J. C. Meier, Pres. & Chief Engr.; F. X. Meier, Prod. Mgr.; H. A. Kehrig, Pur. Dir.

**GEAR GRINDING MACHINE CO.,**

3901 Christopher, Detroit, Mich.  
PERSONNEL: C. N. Macdonald, Pres.; D. W. R. Macdonald, V. Pres.; M. Scheimer, Secy. & Treas.; A. W. Rudel, Sales Mgr.; M. R. King, Pur. Agt.; I. Gruenberg, Chief Engr.

**GEM SHINE PRODUCTS CO.,**

1213 W. 59th St., Chicago, Ill.  
PERSONNEL: G. E. Mortenson, Pres.; A. Stake, V. Pres.; O. Stake, Secy.

**GENERAL ABRASIVE CO., INC.,**

College Ave. & Hyde Park Blvd., Niagara Falls, N. Y.  
PERSONNEL: A. V. Parker, Pres. & Gen. Mgr.; R. Macdonald, Jr., V. Pres.; C. Lockwood, Secy.; H. Richmond, Treas.; A. J. Sandorff, Sales Mgr. & Adv. Mgr.; E. J. Nicholson, Pur. Agt.; O. J. Carpenter, Chief Engr.

**GENERAL AIRCRAFT EQUIPMENT, INC.,**

South Norwalk, Conn.  
PERSONNEL: C. M. Torrey, Pres. & Gen. Mgr.; C. B. H. Deller, V. Pres.; S. M. Loomis, Secy. & Treas.

**GENERAL AIRCRAFT SUPPLY CORP.,**

City Airport, Detroit 5, Mich.  
PERSONNEL: L. F. Zygumt, Jr., Pres.; P. Altman, V. Pres.; H. L. Mitchell, Secy. & Treas.; C. A. Luma, Asst. Treas. & Gen. Mgr.

**GENERAL ARMATURE CORP.,**

Lock Haven, Pa.  
PERSONNEL: Low Mervis, Pres., Treas. & Gen. Mgr.; M. B. Mervis, V. Pres.; M. J. Mervis, Secy.; A. C. Potratz, Prod. Mgr. & Pur. Dir.; Leonard Mervis, Sales Mgr.; J. Petrunak, Pers. Dir.; G. K. Warner, Pub. Dir. & Adv. Mgr.; J. F. Cullin, Chief Engr.

**GENERAL AVIATION EQUIPMENT CO., INC.,**

61-73 Mary St., Ashley, Pa.  
PERSONNEL: V. C. Bell, Pres.; J. M. Faehndrich, V. Pres., Treas. & Gen. Mgr.; H. W. Conroy, Secy.; C. P. Elliott, Pur. Agt.

**GENERAL BRONZE CORP.,**

34-19 10th St., Long Island City 1, N. Y.  
PERSONNEL: W. P. Jacob, Pres.; E. Peremi, V. Pres.; I. L. Martin, V. Pres. & Secy.; W. J. Freeman, Treas.; P. J. Keulemans, Prod. Mgr.; C. C. Moran, Sales Mgr.; H. Meyer, Pur. Dir.; C. Sampson, Pers. Dir.; H. L. King, Pub. Dir.; A. Danielsen, Chief Engr.

**GENERAL CONTROLS CO.,**

801 Allen Ave., Glendale, Calif.  
PERSONNEL: W. A. Ray, Pres. & Chief Engr.; A. W. Ray, V. Pres.; E. T. Howard, Sales Mgr.; H. E. Callahan, Pur. Agt.; C. E. Wilson, Pub. Dir.

**THE GENERAL DETROIT CORP.,**

2272 E. Jefferson Ave., Detroit, Mich.  
PERSONNEL: C. K. Huhsing, Pres. & Treas.; E. A. Warren, V. Pres.; R. L. Braden, Secy.; A. A. Morris, Plant Supt. & Pers. Dir.; F. D. Bacon, Sales Mgr. & Pub. Dir.; C. J. Thoman, Pur. Agt.; C. W. Floss, Chief Engr.

**GENERAL DROP FORGE DIV. OF BROWN-LIPE GEAR CO.,**

1738 Elmwood Ave., Buffalo, N. Y.  
PERSONNEL: C. A. Dana, Pres.; W. B. Breyley, V. Pres.; J. V. Melick, Secy. & Treas.; W. B. Breyley, Jr., Plant Mgr.; B. Herman, Pur. Agt.; J. Gallagher, Pers. Dir.; J. H. Chandler, W. Hopson, Chief Engrs.

**GENERAL ELECTRIC CO.,**

Schenectady, N. Y.  
PERSONNEL: G. Swope, Pres.; E. O. Shreve, V. Pres.; C. H. Lang, V. Pres. & Mgr., Apparatus Sales; J. C. Miller, Mgr., Aviation Div.; R. S. Peare, Mgr., Pub. Div.

**GENERAL ELECTRIC X-RAY CORP.,**

2012 W. Jackson Blvd., Chicago 12, Ill.  
PERSONNEL: J. H. Clough, Pres.; W. S. Kendrick, V. Pres.; E. W. Page, Sales Mgr.; G. E. Simons, Adv. Mgr.

**GENERAL ENGINEERING CO.,**

785 Hertel Ave., Buffalo, N. Y.  
PERSONNEL: W. Johndrew, T. H. Speller, Partners; O. F. Johndrew, Sales Mgr.; E. D. Williams, Pur. Agt.; J. A. Randolph, Chief Engr.

**GENERAL MANUFACTURING CO.,**

6430 Farnsworth Ave., Detroit 11, Mich.  
PERSONNEL: F. C. Hossie, Pres. & Gen. Mgr.; H. F. Marsh, Secy. & Sales Mgr.

**GENERAL RADIO CO.,**

30 State St., Cambridge 39, Mass.  
PERSONNEL: M. Eastham, Pres. & Chief Engr.; E. H. Locke, V. Pres.; H. B. Richmond, Treas.; C. C. Carey, Prod. Mgr.; A. E. Thissen, Sales Mgr.; W. H. Sherwood, Pur. Dir.; C. E. Worthen, Adv. Mgr.

**GENERAL SCIENTIFIC EQUIPMENT CO.,**

1346-48 W. Somerset St., Philadelphia 32, Pa.  
PERSONNEL: M. Kline, Owner.

**THE GEOMETRIC TOOL CO.,**

One Valley St., New Haven 15, Conn.  
PERSONNEL: J. W. Hook, Pres.; A. S. Redway, V. Pres.; G. A. Denison, Sales Mgr.; G. S. Tracy, Adv. Mgr.; A. F. Breitenstein, Chief Engr.

**E. A. GERLACH CO.,**

3567-71 Sepviva St., Philadelphia, Pa.  
PERSONNEL: R. G. Gerlach, Pres. & Treas.; T. W. Cleeland, Sales Mgr.

**GIDDINGS & LEWIS MACHINE TOOL CO.,**

142 Doty St., Fond du Lac, Wis.  
PERSONNEL: H. B. Kraut, Pres.; R. E. Hanson, Exec. V. Pres. & Secy.; W. E. Rutz, V. Pres. & Chief Engr.; K. F. Gallimore, Sr., V. Pres. & Chief Engr.; F. Seese, Treas.; R. A. Breitung, Asst. Treas.; E. K. Morgan, Sales Mgr.; R. E. Breitung, Pur. Dir.; E. E. Wagner, Adv. Mgr.

**GILBERT & BARKER MFG. CO.,**

West Springfield, Mass.  
PERSONNEL: S. C. Hope, Pres. & Gen. Mgr.; P. H. Bills, V. Pres. & Treas.; T. C. O'Donnell, V. Pres.; G. MacDonald, Secy.; W. C. Leitch, Sales Mgr.; H. D. Foss, Pur. Dir.; R. B. White, Adv. Mgr.

**GILFILLAN BROS. INC.,**

1815 Venice Blvd., Los Angeles 6, Calif.  
PERSONNEL: S. W. Gilfillan, Pres. & Gen. Mgr.; A. J. Brown, V. Pres. & Sales Mgr.; I. Kemp, Secy. & Treas.; L. B. Sparks, Prod. Mgr.; J. L. Forrest, Pur. Dir.; J. E. Nevins, Pers. Dir.; L. L. Howell, Pub. Dir. & Adv. Mgr.; C. F. Wolcott, Jr., Chief Engr.



Section of Republic Vari-Typed form showing use of changeable types.

# VARI-TYPER

*Reduces*

## OUTSIDE PRINTING COSTS

for **REPUBLIC AVIATION CORP.**

HERE IS THE STORY IN REPUBLIC'S OWN WORDS:

"The Vari-Typer is used in the Production Planning Division... The work it performs is varied - special report forms, percentage breakdowns, price lists, explanatory notes on graphs, form letters, etc.

"In an organization of this kind, the Vari-Typer fills our unique need for a machine that can prepare paper work...with the very minimum of time and economy. In the eight

months that we have had the machine we find that the biggest saving will be in our reduced outside printing costs."

Other Aviation firms using Vari-Typer are: *Bell, Bendix, Boeing, Brewster, Glenn Martin, Consolidated, Curtiss-Wright, Douglas, Hughes, Eclipse, Lockheed, North American, Pratt & Whitney, Vultee, Wright Aeronautical, Vought Sikorsky.*

For complete details on Vari-Typer write:

| ENG. RELEASE     |          | ORDERED BY PRODUCTION PLANNING |      |          |         |     |     |
|------------------|----------|--------------------------------|------|----------|---------|-----|-----|
| ARTICLE NO.      | DATE     | P.P. NO.                       | DATE | QUANTITY | PROJECT | PLP | ST. |
|                  |          |                                |      |          |         |     |     |
| DIE PATTERN ORD. |          | VENDOR                         |      |          |         |     |     |
| SAMPLE LEAD      |          |                                |      |          |         |     |     |
| EXP.             | REC'D    |                                |      |          |         |     |     |
| REP.             | APP'D    |                                |      |          |         |     |     |
| RET'D            | S.W. NO. |                                |      |          |         |     |     |
| COST INFORMATION |          |                                |      |          |         |     |     |

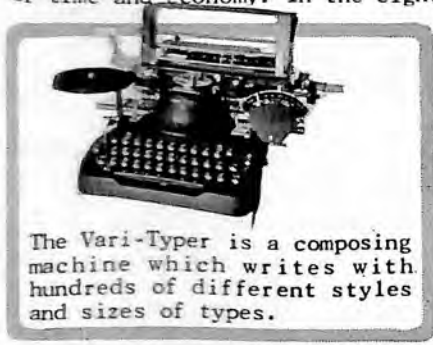

The Vari-Typer is a composing machine which writes with hundreds of different styles and sizes of types.

### RALPH C. COXHEAD CORPORATION

333 SIXTH AVE. • NEW YORK 14, N. Y.

TEXT TYPE SET,  
ON VARI-TYPER

WE ARE MANUFACTURERS OF HYDRAULIC GEAR PUMPS AND SELECTOR VALVES FOR THE ARMY AIR CORPS

---

## *WITH THIS COMPLETE LINE IT'S EASY TO BUY*

---



Light-weight precision-balance G-E aircraft **motors** are made from 1/200 to 7 hp. Speeds range from 1750 to 7500 rpm. Series-, compound-, or shunt-wound, they meet various applications. Standard Air Corps flange mounting styles 2 to 4.

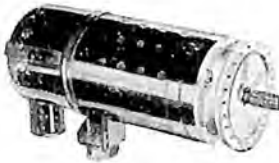

Excellent commutation under the most unfavorable conditions make General Electric **generators** for aircraft a dependable source of electric power. They combine light weight with a high output.



**Dynamotors** are effective for providing the voltage necessary for radio operation. They are light, compact, and efficient, and deliver high outputs. G-E experience in building standard and special dynamotors is assurance of reliable service.



Although it's small, the **G-E Switchette** has double-break contact construction. It weighs only  $\frac{1}{3}$  ounce and measures  $1\frac{3}{4}$  by  $\frac{1}{2}$  by  $\frac{1}{32}$  in. Made in single- or two-circuit form. One contact normally open—one closed; or vice versa.



**Dynamotor contactor**—will handle an inrush of 500 amperes at 32 volts. It operates on either 12 or 24 volts, d-c. Provides one single-pole normally open contact; has a 50-ampere rating based on NEMA 8-hour test.

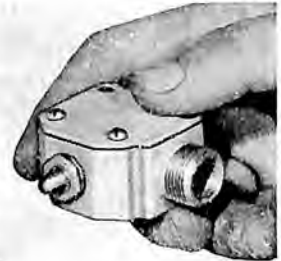

**Limit switch**, light in weight, especially designed for aircraft applications. It is small, and has snap-action double-break contacts that give the switch a high current rating. It is suitable for applications where vibration is severe.

# OF PLANE EQUIPMENT FROM General Electric



Voltage regulators to maintain correct voltage, relays to control generator flow, complete the electric generating system.

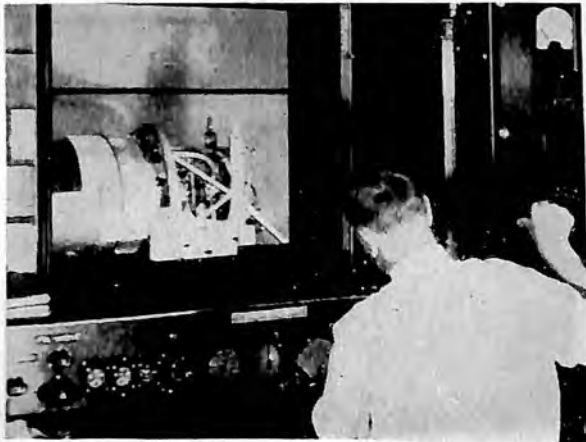

General Electric engineering helped promote these developments; also laboratory testing equipment. G-E dynamometers and testing equipment to meet any requirements.



A complete line of aircraft instruments is available from General Electric. The instrument shown is a typical indicator that provides accurate indications from remote stations. Some of the many other G-E precision aircraft instruments include flight and pilot-control instruments, and others that indicate position, pressure, liquid level, engine speed, and engine temperature.

In the electrically heated flying suit for high-altitude flying, also engineered by G.E., resistance wires, controlled by cigarette-sized thermostats embedded in the ma-

terial, keep temperature constant. Boots, gloves, and suit are connected separately.



**PRECISION PRODUCTS  
and ENGINEERED SYSTEMS  
FOR AIRCRAFT**

**GENERAL  ELECTRIC**

640-127

**SCHENECTADY, N. Y.**

**JOHN W. GILLETTE & CO.,**  
901 Stephenson Bldg., Detroit 2, Mich.  
PERSONNEL: J. W. Gillette, Jr., Pres.

**GISHOLT MACHINE CO.,**  
Madison 3, Wisc.

PERSONNEL: G. H. Johnson, Pres.; H. S. Johnson, A. B. Morey, V. Pres.; C. K. Swafford, V. Pres. & Gen. Mgr.; G. M. Class, V. Pres. & Chief Engr.; G. E. Gernon, Secy.; W. Bissell, Prod. Mgr.; F. L. Chapman, Sales Mgr.; R. K. Newton, Pur. Dir.; J. Toohey, Pers. Dir.; J. C. Sammis, Adv. Mgr.

**GLEASON WORKS,**  
1000 University Ave., Rochester 3, N. Y.  
PERSONNEL: J. E. Gleason, Pres.; N. A. Bullis, Secy.; E. B. Gleason, Treas. & Gen. Mgr.; S. H. Earl, Prod. Mgr.; B. H. Bickle, Sales Mgr.; M. Barker, Pur. Dir.; J. Williams, Pers. Dir.; H. L. Klein, Adv. Mgr.; A. L. Stewart, Chief Engr.

**GLENN-ROBERTS CO.,**  
1009 Fruitvale Ave., Oakland, Calif.  
PERSONNEL: G. G. Glenn, Pres.; P. A. Carrothers, Secy.; J. E. Vosburgh, Sales Mgr.; J. C. Weaver, Pur. Dir.; D. C. Girard, Chief Engr.

**THE GLIDDEN CO.,**  
11001 Madison Ave., Cleveland, O.  
PERSONNEL: A. D. Joyce, Pres.; R. H. Horsburgh, V. Pres.; C. M. Kolb, Secy.; J. A. Peters, Treas.; D. P. Joyce, Gen. Mgr.; J. L. Noon, Sales Mgr.; J. M. Stadter, Pur. Dir.; C. L. Cole, Pers. Dir.; P. L. Lotz, Pub. Dir.; O. F. Shobe, Chief Engr.

**GLOBE HOIST CO.,**  
1000 E. Mermaid Lane, Philadelphia 18, Pa.  
PERSONNEL: W. Swanson, Sr., Pres. & Gen. Mgr.; H. D. Smith, V. Pres. & Sales Mgr.; S. R. Eller, Secy. & Treas.; O. C. Daenzer, Prod. Mgr.; C. W. Brayton, Pur. Dir.; A. Leidy, Pers. Dir., Pub. Dir. & Adv. Mgr.; C. W. Bristol, Chief Engr.

**GLOBE STEEL TUBES CO.,**  
3839 W. Burnham St., Milwaukee 4, Wisc.  
PERSONNEL: W. C. Buchanan, Pres.; F. J. O'Brien, V. Pres. & Sales Mgr.; G. O. Ross, Secy. & Treas.; G. W. Walzer, Works Mgr.; A. Korsan, Dir. of Pur. & Adv. Mgr.; E. Wrage, Chief Engr.

**GODDARD-JACKSON CO.,**  
935 Santa Fe Ave., Los Angeles, Calif.  
PERSONNEL: A. C. Goddard, Pres. & Gen. Mgr.; A. E. Fouts, V. Pres. & Sales Mgr.; M. L. Hilands, Secy. & Treas.; P. E. Boyd, Pur. Dir.

**THE GOGGLE PARTS CO.,**  
Blackstone Bldg., Cleveland, O.  
PERSONNEL: W. R. Paterson, J. D. Hill, Partners.

**THE B. F. GOODRICH CO.,**  
500 S. Main Street, Akron, O.  
PERSONNEL: J. L. Collyer, Pres.; T. G. Graham, J. J. Newman, G. W. Vaught, V. Pres.; S. M. Jett, Secy.; L. L. Smith, Treas.; G. E. Brunner, Gen. Mgr.-Automotive, Aviation & Government Sales Div.; J. S. Pedler, Mgr.-Aeronautical Div.; A. D. Moss, Pur. Dir.; C. V. Motesworth, Pers. Dir.; H. W. Maxson, Pub. Dir.; F. T. Tucker, Adv. Mgr.

**GOODYEAR AIRCRAFT CORP.,**  
Akron 15, O.  
PERSONNEL: P. W. Litchfield, Pres.; E. J. Thomas, P. E. H. Leroy, V. Pres.; H. E. Blythe, V. Pres. & Gen. Mgr.; R. DeYoung, V. Pres.-Prod.; K. Arnstein, V. Pres.-Engrg.; T. Knowles, V. Pres.-Sales; Z. C. Osland, Treas.; H. L. Hyde, Secy.; C. H. Brook, Compt.; L. E. Judd, Pub. Rel. Dir.; J. K. Hough, Adv. Dir.

**GOODYEAR TIRE & RUBBER CO.,**  
Akron, O.  
PERSONNEL: E. J. Thomas, Pres.; R. S. Wilson, P. E. H. Leroy, C. Slusser, H. E. Blythe, J. M. Linforth, J. E. Mayl, V. Pres.; W. D. Shilts, Secy.; Z. C. Osland, Treas.; V. R. Jacobs, Mgr. Aeronautics Dept.; R. S. Wilson, Sales Mgr.; E. H. Brooks, Pur. Agt.; R. S. Pope, Pers. Dir.; L. E. Judd, Pub. Dir.; H. A. Flanner, Chief Engr.

**GOULD & EBERHARDT, INC.,**  
433 Fabyan Place, Newark, N. J.  
PERSONNEL: F. L. Eberhardt, Pres. & Gen. Mgr.; U. Eberhardt, V. Pres. & Treas.; H. Eberhardt, Secy. & Pur. Agt.; G. E. Spies, Sales Mgr.; W. F. Zimmermann, Chief Engr.

**GOULD STORAGE BATTERY CORP.,**  
35 Neoga St., Depew, N. Y.  
PERSONNEL: A. H. Daggett, Pres.; H. G. Barnes, V. Pres. & Gen. Mgr.; J. C. Sykora, V. Pres.-Sales; J. L. Rupp, V. Pres.-Engrg.; H. G. McKay, V. Pres.-Prod.; C. R. Bachmann, Secy.; E. F. Cary, Treas.; P. J. Carlsen, Works Mgr.; E. J. Suttell, Pur. Agt.; R. D. Thomas, Pers. Mgr.; K. Dawkins, Adv. Mgr.; R. W. Hollingsworth, Sales Promotion Mgr.; A. H. Snyder, Chief Design Engr.

**THE GOVRO-NELSON CO.,**  
1931 Antoinette, Detroit, Mich.  
PERSONNEL: V. Gauvreau, Gen. Mgr.

**THE GRAHAM MFG. CO., INC.,**  
47 Bridge St., East Greenwich, R. I.  
PERSONNEL: J. C. B. Washburn, Pres., Treas. & Gen. Mgr.; K. R. Dunnell, Secy.

**GRAHAM ROTARY FILE & TOOL CO.,**  
387 Fourth Ave., New York 16, N. Y.

**L. F. GRAMMES & SONS, INC.,**  
Allentown, Pa.  
PERSONNEL: F. Weindel, Jr., Pres. & Treas.; R. Lamont, V. Pres.; W. G. J. Baur, Secy.; L. D. Kiechel, Sales Mgr.; J. A. Schaefer, Pur. Agt.

**GRANBERG EQUIPMENT, INC.,**  
1308-67th St., Oakland 8, Calif.  
PERSONNEL: A. J. Granberg, Pres.; R. W. Lindsay, V. Pres. & Sales Mgr.

**GRAND RAPIDS INDUSTRIES, INC.,**  
Grand Rapids, Mich.  
PERSONNEL: F. H. Mueller, Pres. & Gen. Mgr.; C. M. Kindel, V. Pres.; S. F. Dunn, Secy.; H. W. Nelson, Prod. Mgr.; B. M. Fox, Pur. Dir.; M. R. Clark, Pers. Dir.; W. B. MacWhirter, Chief Engr.

**GRATON & KNIGHT CO.,**  
356 Franklin St., Worcester, Mass.  
PERSONNEL: A. L. Bennett, Pres. & Treas.; G. L. Abbott, V. Pres. & Sales Mgr.; C. O. M. Howarth, Plant Supt.; J. A. Hawkesworth, Prod. Mgr.; G. A. Barnard, Pur. Dir.; J. G. Kapowich, Pers. Dir.; C. E. Downing, Pub. Dir. & Adv. Mgr.; W. F. Robbins, Chief Engr.

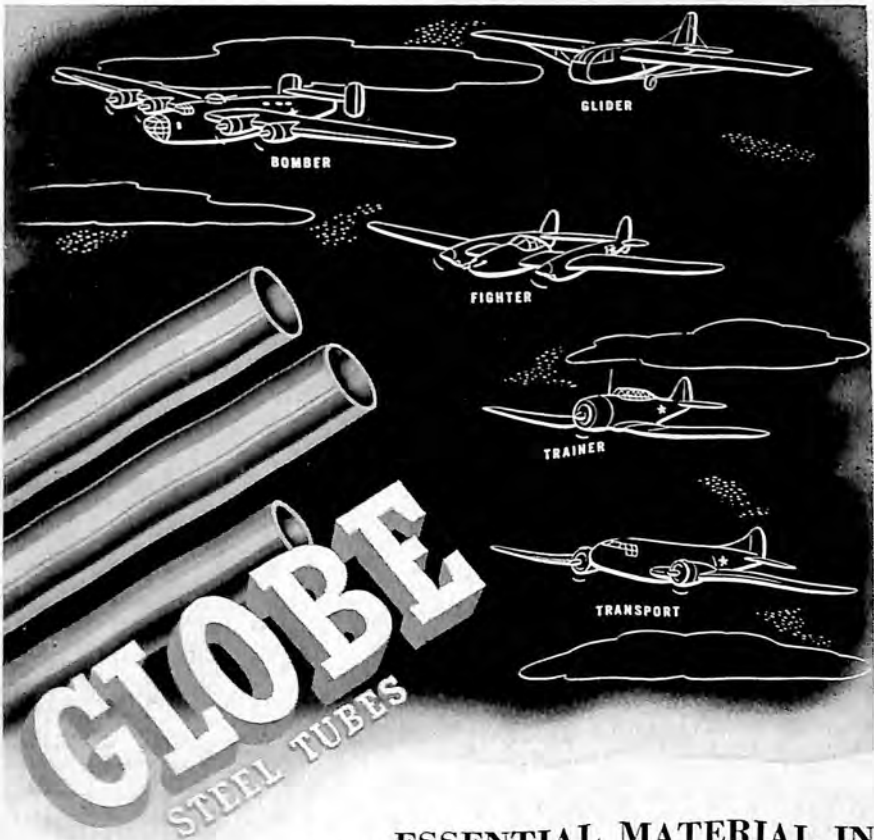

... ESSENTIAL MATERIAL IN  
**THE CONSTRUCTION OF MODERN AIRCRAFT**

**M**ORE than 83 different parts used in modern aircraft construction involve the use of Globe Steel Tubes — including Globe seamless carbon, alloy and stainless steel tubes, as well as Gloweld welded stainless steel tubing.

Great structural strength with minimum weight — adaptability and easy machine-ability — uniformity — qualify Globe steel tubes for applications ranging from small stator shells in fractional horsepower motors, as used aboard planes, to sturdy cylinders required for hydraulic landing gear.

|                    |                                            |
|--------------------|--------------------------------------------|
| <b>GLOBE</b>       |                                            |
| ★ STAINLESS TUBES  | ★ CONDENSER AND<br>HEAT EXCHANGER<br>TUBES |
| ★ BOILER TUBES     | ★ MECHANICAL TUBING                        |
| ★ GLOBEIRON TUBING |                                            |
| ★ GLOWELD TUBES    |                                            |

**GLOBE STEEL TUBES CO. MILWAUKEE, WIS., U. S. A.**



**G. A. GRAY CO.,**

3611 Woodburn Ave., Cincinnati, O.  
 PERSONNEL: H. Marx, Pres.; A. Marx, V. Pres. & Gen. Mgr.; A. Zuest, Secy. & Treas.; J. E. Doran, Sales Mgr.; R. Jeggie, Pur. Agt.; E. Henke, Pers. Dir.; J. Walter, Chief Engr.

**GRAY RADIO CO., West Palm Beach, Fla.**

PERSONNEL: F. E. Gray, Owner & Chief Engr.; G. H. De Shazo, Gen. Mgr. & Pur. Agt.

**GREAT WESTERN STEEL CO., INC.,**

1011 E. 61st St., Los Angeles, Calif.  
 PERSONNEL: C. G. Hoyland, Pres.; F. X. Moore, V. Pres.; R. A. Moore, Secy. & Treas.

**THE GREIST MFG. CO.,**

Blake St., New Haven, Conn.

**GRIMES MANUFACTURING CO.,**

515 N. Russell St., Urbana, O.  
 PERSONNEL: W. G. Grimes, Pres.; C. Grimes, V. Pres.; N. Black, Secy.; D. O. Printz, Prod. Mgr.; L. B. Moore, Sales Mgr. & Chief Engr.; H. Hanna, Pur. Dir.; M. Wyant, Pers. Dir.

**GRINNELL CO., INC.,**

260 W. Exchange St., Providence, R. I.  
 PERSONNEL: R. Grinnell, Pres.; J. D. Fleming, V. Pres., Gen. Mgr. & Sales Mgr.; R. T. Clapp, Secy.; L. W. Jones, Treas.; C. P. Riegger, Pur. Agt.

**GROB BROTHERS, Grafton, Wis.**

PERSONNEL: B. Grob, T. Grob, Partners & Gen. Mgrs.; L. W. Rothe, Pur. Agt.

**GUARDIAN ELECTRIC MANUFACTURING CO., 1400 Washington Blvd., Chicago 7, Ill.**

PERSONNEL: F. F. Rowell, Pres.; F. F. Rowell, Jr., V. Pres. & Gen. Mgr.; J. J. Rowell, Secy.; W. Rowell, Treas. & Pur. Dir.; A. Hansen, Prod. Mgr.; E. A. Sibb, Sales Mgr.; H. Eschenfelder, Pers. Dir.; C. A. Bowman, Pub. Dir. & Adv. Mgr.; N. Nelsen, Chief Engr.

**GUIBERSON DIESEL ENGINE CO.,**

1000 Forest Ave., Dallas, Tex.  
 PERSONNEL: S. A. Guiberson, Jr., Pres.; A. Guiberson, V. Pres.; R. D. Wallis, Secy., Treas. & Pers. Dir.; C. H. Guillion, Gen. Mgr.; J. B. Story, Sales Mgr. & Pub. Dir.; W. N. Rathbun, Pur. Dir.; W. E. Lind, Exec. Engr.

**W. & L. E. GURLEY, Troy, N. Y.**

PERSONNEL: C. I. Day, Pres. & Gen. Mgr.; E. H. Betts, V. Pres.; H. M. Dibert, Secy., Treas. & Sales Mgr.; H. C. Larson, Chief Engr.

**THE EDWIN F. GUTH CO.,**

2617 Washington Ave., St. Louis, Mo.  
 PERSONNEL: E. F. Guth, Pres.; J. B. Guth, V. Pres.; F. E. Guth, Secy. & Pub. Dir.; O. D. Guth, Treas. & Chief Engr.; G. S. Watts, Gen. Mgr. & Sales Mgr.; R. M. Stradal, Pur. Agt.; A. C. Steck, Pers. Dir.

**H****H-B ELECTRIC CO., INC.,**

6117 N. 21st St., Philadelphia, Pa.  
 PERSONNEL: W. E. Girard, Gen. Mgr.

**C. M. HALL LAMP CO.,**

1035 E. Hancock Ave., Detroit, Mich.  
 PERSONNEL: W. F. Anklam, Pres.; B. D. Granger, V. Pres.; G. A. Haire, Secy. & Treas.; J. W. Schmitt, Sales Mgr.; J. A. Janisse, Pur. Agt.; C. W. Anklam, Chief Engr.

**THE HALL MFG. CO.,**

1600 Woodland Ave., Toledo 7, O.  
 PERSONNEL: F. A. Hall, Pres.; R. P. Hall, V. Pres.; G. W. Smith, Sales Mgr. & Adv. Mgr.; W. Kopman, Pur. Dir.; W. Beard, Pers. Dir.; R. S. Beverlin, Chief Engr.

**THE HALL PLANETARY CO.,**

Fox St. & Abbottsford Ave., Philadelphia, Pa.

PERSONNEL: P. Hall, Pres. & Gen. Mgr.; H. J. Ries, Secy. & Treas.; H. C. Sheaffer, Sales Mgr.; C. K. Lennig, Pur. Dir.

**THE HALLCRAFTERS CO.,**

2611 Indiana Ave., Chicago, Ill.  
 PERSONNEL: W. J. Halligan, Sr., R. W. Durst, Jr., Co-Partners; R. E. Samuelson, Chief Engr.; J. G. Thompson, Credit Mgr.; J. J. Frendreis, Compt.; M. Ortiz, Jr., Export Mgr.; E. J. Corcoran, Pur. Agt.; E. G. Brown, Adv. Mgr.

**HAMILTON STANDARD PROPELLERS, DIV. OF UNITED AIRCRAFT CORP.,**

362 S. Main St., Hartford 8, Conn.  
 PERSONNEL: H. M. Horner, Pres.; S. A. Stewart, V. Pres. & Gen. Mgr.; C. J. McCarthy, V. Pres.; C. H. Chatfield, Secy.; C. L. Gault, Treas.; J. F. McCarthy, Controller; H. M. Ellis, Sales Mgr.; N. V. Clements, Dir. Pub. & Adv.; G. B. Martin, Pub. Rep.; A. C. Wolz, Pur. Agt.; W. T. Beebe, Pers. Supervisor; C. F. Baker, Asst. Chief Engr.

**THE HAMILTON STEEL CO.,**

E. 131st and Taft Ave., Cleveland, O.  
 PERSONNEL: H. K. Hamilton, Pres.; D. C. Van Pelt, V. Pres.; W. C. Thompson, Treas. & Gen. Mgr.; E. W. Smith, Pur. Agt.

**HAMILTON-WADE CO.,**

52-62 Haverhill St., Brockton 62, Mass.  
 PERSONNEL: J. Christie, Pres., Treas. & Gen. Mgr.; F. A. Fisher, V. Pres. & Sales Mgr.; M. Teixeira, Prod. Mgr.

**HAMMOND MACHINERY BUILDERS, INC., 1686 Douglas Ave., Kalamazoo, Mich.**

PERSONNEL: L. Hammond, Pres. & Gen. Mgr.; A. T. Vander Linde, S. H. Miller, Sales Engrs.; R. N. Shaw, Pur. Agt.; H. J. Kingsbury, Chief Engr.

**HANDY & HARMAN,**

82 Fulton St., New York 7, N. Y.  
 PERSONNEL: G. H. Niemeyer, Pres.; R. H. Leach, V. Pres.-Prod.; J. C. Travis, V. Pres.-Sales; H. W. Spaulding, Secy.; H. W. Boynton, Treas.; J. W. Colgan, Sales Mgr.; F. T. Van Syckel, Adv. Mgr.

**HANNIEN MANUFACTURING CO.,**

621-631 S. Kolmar Ave., Chicago, Ill.

**HANSON-VAN WINKLE-MUNNING CO.,**

Church St., Matawan, N. J.  
 PERSONNEL: V. W. Todd, Pres.; C. W. Yerger, Exec. V. Pres.; L. M. Hague, V. Pres.-Sales; G. Todd, V. Pres.-Engrg.; N. Todd, Secy.; N. A. Munning, Asst. Treas.; R. J. Malkmus., Pur. Agt.; T. S. Byrne, Pers. Dir.; J. Vander-Voort, Pub. Dir.

**HARBOR PLYWOOD CORP.,**

Hoquiam, Wash.  
 PERSONNEL: E. W. Daniels, Pres.; H. F. Wise, Secy.; B. Sjoblom, Pur. Agt.; M. S. Munson, Pub. Dir.

**HARDINGE BROTHERS, INC.,**

Elmira, N. Y.  
 PERSONNEL: D. G. Anderson, Pres.; L. R. Evans, V. Pres.; D. R. Laux, V. Pres.-Sales & Adv. Mgr.; W. H. Mandeville, Secy.; A. F. Fischer, Treas.; J. S. McCarty, Prod. Mgr.; J. S. Nethth, Pur. Dir.; E. D. Harvey, Pers. Dir.; A. Daddona, Chief Engr.

# **HALLICRAFTERS WAS READY!**



Under the abnormal climatic and operating conditions of war, the Signal Corps SCR-299 communications truck, built by Hallicrafters, is providing peak performance for the Allied armed forces, fighting throughout the world.

Hallicrafters peacetime communications equipment is meeting the wartime qualifications and demands of the Military!

Just as Hallicrafters Communications receivers are meeting the demands of war Today — they shall again deliver outstanding reception for the Peace — Tomorrow!

**hallicrafters**  **BUY MORE BONDS**

*World's largest exclusive manufacturer of short wave radio communications equipment . . . First exclusive radio manufacturer to win the Army-Navy Production Award for the third time.*

**HARDMAN AIRCRAFT PRODUCTS, INC.,**  
12324 Center St., South Gate, Calif.  
PERSONNEL: F. Hardman, Pres. & Chief Engr.; A. C. Mackay, V. Pres.; E. I. Hamilton, Secy.; J. R. Paige, Treas.; T. F. Hamilton, Gen. Mgr.; A. Turner, Pur. Agt.; W. O. Payne, Pers. Dir.; R. S. Elliott, Pub. Dir.

**HARDMAN, PECK & CO.,**  
524-542 W. 52nd St., New York, N. Y.  
PERSONNEL: E. A. Schmitt, Pres. & Gen. Mgr.; M. B. Colwin, V. Pres. & Pers. Dir.; H. F. Hagemeyer, Secy. & Sales Mgr.; M. Barile, Treas.; J. Aptacy, Pur. Agt.; J. Sauerland, Chief Engr.

**THE HARDWARE SPECIALTIES MFG. CO.,**  
125 Bruce Ave., Stratford, Conn.  
PERSONNEL: J. J. Zimmer, Pres. & Pers. Dir.; S. Zimmer, V. Pres. & Treas.; E. Zimmer, Secy., Gen. Mgr., Sales Mgr. & Pur. Dir.; J. Zimmer, Prod. Mgr.; A. I. Zimmer, Chief Engr.

**HARDWICK, HINDLE, INC.,**  
40 Hermond St., Newark, N. J.  
PERSONNEL: A. H. Hardwick, Pres., Sales Mgr. & Pub. Dir.; R. Golden, V. Pres.; J. A. Greene, Secy. & Treas.; W. R. Davis, Gen. Mgr.; H. Moffett, Pur. Agt.; G. Krohn, Pers. Dir.; D. Hastings, Chief Engr.

**HARLOW AIRCRAFT CO.,**  
620 E. Valley Blvd., Alhambra, Calif.  
PERSONNEL: H. F. Keenan, Pres.; F. Der Yuen, V. Pres. & Gen. Mgr.; J. E. Addicott, Jr., V. Pres., Secy. & Pub. Dir.; E. L. McCreary, Treas.; J. T. Arenz, Pur. Agt.; M. H. Gray, Pers. Dir.; D. C. Mendenhall, Chief Engr.

**HARRINGTON & RICHARDSON ARMS CO.,** 320 Park Ave., Worcester, Mass.  
PERSONNEL: J. Clark, Jr., Pres.; F. A. Smith, V. Pres. & Gen. Mgr.; H. C. Walsh, Secy.; O. L. Stanhope, Asst. Treas.; P. A. Warren, Pur. Agt.; F. Devlin, Pers. Dir.; J. Smith, Chief Engr.

**THE HARRIS CALORIFIC CO.,**  
5501 Cass Ave., N. W., Cleveland, O.  
PERSONNEL: L. Campbell, Jr., Pres. & Gen. Mgr.; J. T. Feighan, V. Pres.; J. R. Milligan, Secy. & Treas.

**HARRIS PRODUCTS CO.,**  
5105 Cowan Ave., Cleveland, O.  
PERSONNEL: B. M. Kent, Pres., Treas. & Gen. Mgr.; A. D. Harris, V. Pres.; J. M. Carter, Secy.; C. C. Casper, Prod. Mgr.; C. R. Wight, Pur. Dir.; D. T. Bradley, Chief Engr.

**HARRIS SEYBOLD POTTER CO., SEYBOLD DIV.,** 819 Washington St., Dayton F7, O.  
PERSONNEL: R. V. Mitchell, Pres.; A. S. Harris, V. Pres.; G. S. Dively, Secy. & Treas.; N. McGowan, Prod. Mgr.; N. O. Scourfield, Works Mgr.; J. C. Dabney, Sales Mgr. & Adv. Mgr.; H. B. Irwin, Pur. Dir.; R. Kantner, Pers. Dir.; W. R. Spiller, Chief Engr.

**HARRISON RADIATOR DIV., GENERAL MOTORS CORP.,** Lockport, N. Y.  
PERSONNEL: F. M. Hardiman, Gen. Mgr.; G. H. Hetley, Compt.; L. J. Schneider, Sales Mgr.; I. D. Jenkins, Pers. Mgr.; K. F. Covert, Pub. Rel. Mgr.

**THE HART MANUFACTURING CO.,**  
110 Bartholomew Ave., Hartford, Conn.  
PERSONNEL: G. H. Hart, Pres.; E. E. Legge, V. Pres. & Gen. Mgr.; P. H. Hensel, Secy. & Treas.; J. W. C. Price, Sales Mgr. & Pub. Dir.; R. B. Sturupp, Pur. Agt.; J. T. Heaton, Pers. Dir.; S. C. Williams, Chief Engr.

**HARTFORD MACHINE SCREW CO.,**  
476 Capitol Ave., Hartford, Conn.  
PERSONNEL: H. E. Penfield, Pres.; J. A. Taylor, V. Pres. & Gen. Mgr.; W. McCarroll, Secy., Sales Mgr. & Adv. Mgr.; A. R. Grane, Treas.; J. F. Miller, Prod. Mgr.; P. B. Fitzpatrick, Pers. Dir.; E. Grimmisen, Chief Engr.

**HARTZELL PROPELLER CO.,**  
Piqua, O.  
PERSONNEL: R. N. Hartzell, Pres.; R. I. Blayney, V. Pres.; R. B. Reck, Secy.; R. V. Hartzell, Treas.; C. F. Reed, Gen. Mgr.; R. W. Zimmerman, Sales Mgr.; M. C. Wright, Pur. Dir.; F. J. Charavay, Chief Engr.

**HARVEY MACHINE CO., INC.,**  
6200 Avalon Blvd., Los Angeles 3, Calif.  
PERSONNEL: L. M. Harvey, Pres. & Gen. Mgr.; L. A. Harvey, V. Pres.; D. C. Silverthorne, Treas.; E. L. Forrow, Sales Mgr.; E. D. Krentzman, Pur. Dir.; A. N. Coleman, Pers. Dir.; W. R. Latta, Pub. Dir.

**HARVEY RADIO LABORATORIES, INC.,**  
447 Concord Ave., Cambridge, Mass.  
PERSONNEL: F. Lyman, Jr., Pres.; J. E. McDonald, Sales Mgr.

**HARVEY-WELLS COMMUNICATIONS INC.,**  
North St., Southbridge, Mass.  
PERSONNEL: J. M. Wells, Pres. & Treas.; R. A. Mahler, V. Pres. & Gen. Mgr.; C. A. Harvey, V. Pres. & Chief Engr.; D. M. Dubreuil, Secy.; J. Topa, Prod. Mgr.; B. Follett, Sales Mgr.; J. W. Welch, Pur. Dir.; J. K. Edwards, Pers. Dir.

**HARVILL CORP.,** 6251 W. Century Blvd., Los Angeles, Calif.  
PERSONNEL: F. M. Hocfler, Pres.; W. G. Stratton, Secy. & Treas.; D. R. Taylor, Pur. Agt.; G. C. Jaynes, Pers. Dir.; P. R. Jordan, Pub. Dir.; A. A. Turton, Chief Engr.

**THE HARWOOD CO., DIV. OF LOS ANGELES CORP.,** 540 N. La Brea Ave., Los Angeles 36, Calif.  
PERSONNEL: E. C. Simmons, Pres.; R. F. Ingold, V. Pres.; G. J. Livingston, V. Pres. & Gen. Mgr.; W. R. Hilker, Asst. Secy.; J. Byrd, Prod. Mgr.; L. D. O'Connell, Sales Mgr.; F. A. Von Baum, Pur. Dir.; T. Wright, Pers. Dir.; A. C. Pearson, Chief Engr.

**HASKELITE MANUFACTURING CORP.,**  
Grand Rapids 2, Mich.  
PERSONNEL: G. R. Meyercord, Jr., Pres.; H. Bersie, V. Pres.; O. H. Basquin, V. Pres.; F. M. Curran, V. Pres. & Prod. Mgr.; V. S. Barnes, V. Pres. & Sales Mgr.; J. Harrington, Secy.; H. Dunton, Treas.; H. Bostwick, Pur. Dir.; M. Hoysington, Pers. Dir.; J. B. Van Domtelen, Adv. Mgr.; J. A. Potchian, Chief Engr.

**JOHN HASSALL, INC.,**  
394 Oakland St., Brooklyn, N. Y.  
PERSONNEL: T. B. Smith, Pres.; J. Smith, V. Pres.; W. W. Smith, Secy. & Pur. Agt.; J. H. Hassall, Treas.; E. F. Karnes, Pub. Dir.

**HATHAWAY INSTRUMENT CO.,**  
1315 S. Clarkson St., Denver, Colo.  
PERSONNEL: E. R. Wiseman, Pur. Agt.; C. M. Hathaway, Chief Engr.

**HAYES INDUSTRIES, INC.,**  
Jackson, Mich.  
PERSONNEL: C. B. Hayes, Pres. & Gen. Mgr.; C. Hollerith, V. Pres.-Engrg.; E. C. Hetherwick, Secy. & Treas.; J. E. Prins, Prod. Mgr.; H. H. Kerr, Sales Mgr.; G. B. Vass, Pur. Dir.; E. J. Peterson, Pers. Dir.; D. Mackie, Adv. Mgr.; F. H. LeJeune, Chief Engr.

# HASKELITE

## *Leads in*



### AIRCRAFT PLYWOOD (PRODUCTION-RESEARCH)

#### HASKELITE PLYMOLD

Plymold is a new technique in the mass production of molded plywood. Wood veneers are laminated over easily fabricated dies, in small sizes or in sections as large as a bomber fuselage. To meet stress requirements, thickness variations can be ac-

curately molded into any section—ribs or other reinforcing members may be incorporated as an integral part of the structure in a single molding operation. Haskelite's Plymolding capacity is the largest in the United States.

#### AIRCRAFT PANELS

The Haskelite used in today's planes is a functional product—produced to conform to specifications and perform as the plane designer demands. Since World War I, when Haskelite was a

prime source of aircraft plywood, engineering research has created new uses for Haskelite materials by constantly improving their quality and uniformity.

#### BEARING BLOCKS

To provide extra strength at the areas of concentrated stress in wood planes, such as points where fastenings are made, compressed Walnut Bearing Blocks have been developed by Haskelite. They are more easily ma-

chined and glued than other denser materials serving the same purpose. (Where still higher strength is required, Haskelite Compressed and Impregnated wood is specified).

*A six page bulletin on Haskelite Bearing Blocks will be sent to responsible production and research executives in the aircraft industry on request.*

#### HASKELITE MANUFACTURING CORPORATION

Grand Rapids 2, Mich.  
Chicago, Ill. · New York, N. Y. · Detroit, Mich.

**HAYES MANUFACTURING CORP.,**  
Grand Rapids, Mich.

PERSONNEL: R. W. Clark, Pres. & Gen. Mgr.; A. A. Anderson, V. Pres.; T. E. Deañ, Secy.; J. H. Lee, Treas.; L. Pinkowske, Pur. Agt.; R. Schriber, Pers. Dir.; F. F. Bettiger, Factory Mgr.

**HAYNES STELLITE CO.,** Kokomo, Ind.

PERSONNEL: F. M. Gormely, Pres. & Gen. Mgr.; E. E. LeVan, V. Pres.; R. L. Lerch, Sales Mgr.; R. L. Resener, Pur. Dir.

**THE HEALD MACHINE CO.,**

14 New Bond St., Worcester, Mass.

PERSONNEL: R. N. Heald, Pres.; S. T. Massey, V. Pres. & Sales Mgr.; R. S. Heald, Secy.; R. A. Heald, Treas.; G. C. Bestick, Pur. Agt.; H. E. Johnson, Pers. Dir.; L. A. Hastings, Pub. Dir.; W. D. Schmidt, G. D. Scott, Chief Engrs.

**THE HEATH CO.,** 305 Territorial Rd., Benton Harbor, Mich.

PERSONNEL: H. E. Anthony, Pres.; J. E. Ballard, Jr., Prod. Mgr.; D. B. Reagan, Sales Mgr.; W. C. Gard, Pur. Dir.; G. D. Woods, Chief Engr.

**HEIL ENGINEERING CO.,**

12901 Elmwood Ave., Cleveland, O.

PERSONNEL: C. E. Heil, Gen. Mgr.; H. P. Heil, Sales Mgr.; R. K. Otter, Pur. Agt.

**THE HEIM CO.,**

46 Sanford St., Fairfield, Conn.

PERSONNEL: L. R. Heim, Pres. & Chief Engr.; A. E. Heim, V. Pres.; C. R. Heim, Secy., Treas., Gen. Mgr. & Pur. Agt.; E. Hildes-Heim, Sales Mgr.; N. Schollin, Pers. Dir.

**HEINEMANN CIRCUIT BREAKER CO.,**

Trenton, N. J.

PERSONNEL: B. S. Berlin, Pres.; K. W. Wilckens, Secy. & Chief Engr.; H. W. Haenni, Gen. Mgr. & Pur. Agt.; E. Bromberg, Sales Mgr.

**THE HENDEY MACHINE CO.,**

105 Summer St., Torrington, Conn.

PERSONNEL: D. Ayr, Pres. & Gen. Mgr.; E. J. Seybold, V. Pres.; J. H. Markham, Secy. & Treas.; F. J. McCarty, Sales Mgr.; F. N. McKenzie, Pur. Agt. & Pub. Dir.; H. H. Fuessenich, Pers. Dir.; C. Bouillon, Chief Engr.

**HENGER SELTZER CO.,**

130 S. Hewitt St., Los Angeles, Calif.

PERSONNEL: I. R. Seltzer, Pres.; E. W. Henger, Treas.; C. R. Henger, Gen. Mgr. & Sales Mgr.; P. Hough, Pur. Agt.; R. Barkeley, Chief Engr.

**HENRY & WRIGHT MFG. CO.,**

Hartford, Conn.

PERSONNEL: F. K. Simmons, Pres. & Gen. Mgr.; C. F. Sherman, V. Pres.-Sales; H. H. Hilliard, Treas.; R. Whittier, Pur. Agt.; A. E. Caserta, Chief Engr.

**HERRICK IRON WORKS,**

18th &amp; Campbell Sts., Oakland, Calif.

PERSONNEL: S. G. Herrick, Secy.; M. S. Herrick, Treas.; L. A. Peck, Sales Mgr.; E. G. Herman, Pur. Agt.; C. Kehrlein, Pers. Dir.; E. O. Rosberg, Chief Engr.

**ROBERT HETHERINGTON & SON, INC.,**

1216 Elmwood Ave., Sharon Hill, Pa.

PERSONNEL: C. F. Benzel, Pres. & Treas.; J. D. Cox, V. Pres. & Prod. Mgr.; R. K. Hetherington, V. Pres., Sales Mgr., Pub. Dir. & Adv. Mgr.; M. A. Walls, Secy.; J. F. White, Pur. Dir.; C. L. Cox, Pers. Dir.; J. H. Schellman, Chief Engr.

**HEVI DUTY ELECTRIC CO.,**

Milwaukee, Wisc.

PERSONNEL: H. E. Koch, Pres.; N. Bloye, G. A. Chutter, V. Pres.; D. C. Hinstorff, Pur. Agt.; A. H. Oberndorfer, Pub. Dir.

**HEWITT RUBBER CORP.,**

240 Kensington Ave., Buffalo 5, N. Y.

PERSONNEL: T. Robins, Jr., Pres.; F. G. Cooban, V. Pres.; J. H. Hayden, Secy.; E. K. Twombly, Treas.; C. W. Mackett, Sales Mgr.; H. B. Urtel, Pur. Dir.; G. Ennes, Adv. Mgr.; F. W. Blanchard, Chief Engr.

**HEYMAN MANUFACTURING CO.,**

Kenilworth, N. J.

PERSONNEL: H. W. Heyman, Pres.; F. Klumpp, Jr., V. Pres. & Chief Engr.; H. Klumpp, Secy.; K. E. Fahnestock, Treas.; L. H. Palmer, Pers. Dir.

**HIGHBRIDGE-INTERNATIONAL CO.,**

Morris Heights Station, New York 53, N. Y.

PERSONNEL: W. J. Stolz, Prop.

**HILL AIRCRAFT STREAMLINERS CO.,**

700 W. Sixth St., Cincinnati, O.

PERSONNEL: J. A. Hill, Pres.; F. K. Hill, Secy. & Treas.; K. W. Abbott, Gen. Mgr.; W. A. Sundquist, Chief Engr.

**THE HILLIARD CORP.,**

102 W. Fourth St., Elmira, N. Y.

PERSONNEL: A. M. Bovier, Pres.; E. A. Mooers, V. Pres. & Gen. Mgr.; T. A. LaBrecque, Sales Mgr.; F. A. Fisk, Pur. Dir.; J. V. Stowell, Adv. Mgr.; J. Schuckers, Chief Engr.

**HILO VARNISH CORP.,**

42 Stewart Ave., Brooklyn, N. Y.

PERSONNEL: C. J. Schumann, Pres. & Gen. Mgr.; A. G. Schumann, V. Pres.; W. L. Schwalb, Secy., Pur. Agt. & Chief Engr.; F. M. Schumann, Treas.; J. J. Mattiello, Sales Mgr.

**HOBART BROTHERS CO.,**

Hobart Sq., Troy, O.

PERSONNEL: E. A. Hobart, Pres.; W. H. Hobart, V. Pres. & Secy.; D. C. Jenkins, Treas.; E. C. Galbreath, Gen. Mgr. & Sales Mgr.; O. H. Menke, Prod. Mgr.; B. A. Lutz, Pur. Dir.; W. Curtis, Pers. Dir.; S. C. Cairns, Pub. Dir.; C. K. Priest, Adv. Mgr.; R. Flora, Chief Engr.

**HOCKADAY AIRCRAFT CORP.,**

60 E. Orange Grove Ave., Burbank, Calif.

PERSONNEL: N. R. Hockaday, Pres. & Gen. Mgr.; J. B. Sharp, Secy. & Pur. Dir.; R. I. Hockaday, Treas.; A. Swanson, Prod. Mgr.

**HOCKADAY-NEWBY AIRCRAFT, INC.,**

68 E. Orange Grove, Burbank, Calif.

PERSONNEL: N. R. Hockaday, Pres.; H. L. Newby, Secy. & Treas.

**HOLE ENGINEERING SERVICE,**

5901 Fourth Ave., Detroit, Mich.

PERSONNEL: H. C. Satterthwaite, Gen. Mgr.; E. W. Lemon, Pur. Agt.; E. T. Barringer, Chief Engr.

**HOLLEY CARBURETOR CO.,**

5930 Vancouver Ave., Detroit 4, Mich.

PERSONNEL: E. Holley, Pres.; D. W. Candler, V. Pres. & Gen. Mgr.; B. W. Westcott, V. Pres. & Sales Mgr.; G. M. Holley, Jr., V. Pres.; J. F. English, Secy.; H. C. Webb, Pur. Dir.; M. J. Kittler, Chief Engr.



Model AWA  
Seat Grinder  
as used for  
radial engines.



Model EJA  
Seat Grinder for  
seats in in-line  
cylinders.



One type  
of HALL  
Production  
Seat Grinder

Only the BEST is good enough in airplane valve performance. HALL grinding equipment is widely used in the production and servicing of airplane engines because of the finer precision and finish it produces. Write for literature describing these and other types of HALL valve and valve seat grinding equipment.

HALL Valve Refacer with dual motors and rheostat control.



Model AWA  
Seat Grinder as  
used in in-line  
engines.



Model AW  
Seat Grinder for  
seats in radial  
engines.



Battery of AWP  
Seat Grinders  
used by one  
manufacturer.

# HALL

**THE HALL MANUFACTURING CO., TOLEDO 7, OHIO**



**THE HOLO-KROME SCREW CORP., P. O.  
Box 98, Elmwood Branch, Hartford,  
Conn.**

PERSONNEL: W. A. Purtell, Pres., Treas. & Gen. Mgr.; W. C. Stauble, V. Pres., Secy. & Sales Mgr.; H. A. Neff, Pur. Agt., & Pers. Dir.; R. H. Young, Pub. Dir.

**HOOF PRODUCTS CO.,  
6543 S. Laramie Ave., Chicago 38, Ill.**

PERSONNEL: H. C. Kepner, Pres.; W. H. Eckert, V. Pres. & Secy.; F. A. Hoof, Treas.; H. C. Trich, Prod. Mgr. & Chief Engr.; C. E. Johnson, Sales Mgr. & Pers. Dir.; V. H. Eggers, Pur. Dir.; A. Altenberg, C. B. Seymour, J. S. Jennings, Chief Engrs.

**HOPE WEBBING CO.,  
Providence 1, R. I.**

PERSONNEL: C. A. Horton, Pres. & Gen. Mgr.; A. A. Turner, V. Pres., Treas., Pur. Dir. & Adv. Mgr.; H. W. Horton, V. Pres., Prod. Mgr., Pers. Dir. & Pub. Dir.; C. A. Pray, Secy.; H. S. Smith, Sales Mgr.; A. L. Davis, Chief Engr.

**HOUDAILLE-HERSHEY CORP., 2188 Na-  
tional Bank Bldg., Detroit, Mich.**

PERSONNEL: C. Getler, Pres.; R. F. Peo, D. S. Devor, V. Pres.; M. C. Mason, Secy.; G. C. Phelps, Treas.

**E. F. HOUGHTON & CO.,  
303 W. Lehigh Ave., Philadelphia, Pa.**

PERSONNEL: A. E. Carpenter, Pres. & Gen. Mgr.; G. W. Pressell, Exec. V. Pres.; E. A. Carpenter, Secy.; W. F. MacDonald, Treas.; D. J. Richards, Asst. Dir. of Sales; H. B. Fox, Pur. Dir.; T. W. Collins, Pers. Dir.; D. C. Miner, Adv. Mgr.; W. A. Bohne, Chief Engr.

**CHAS. W. HOUSE & SONS, INC.,  
19 Perry St., Unionville, Conn.**

PERSONNEL: H. C. House, Pres.; R. K. Brooks, V. Pres.; J. C. Brash, Asst. Secy., Asst. Treas. & Pur. Agt.

**THE HOWE SCALE CO., Rutland, Vt.**

PERSONNEL: F. G. Riehl, Pres.; A. N. Lyons, V. Pres. & Treas.; H. McK. Dodge, Secy.; V. Carroll, Prod. Mgr.; N. M. Gron, Pur. Dir.; O. T. Baxter, Adv. Mgr.

**HOYT ELECTRICAL INSTRUMENT CO.,  
857 Boylston St., Boston, Mass.**

PERSONNEL: W. C. Hoyt, Gen. Mgr.; C. W. Burton, Sales Mgr.; V. S. Church, Chief Engr.

**HUB INDUSTRIES INC.,  
38-04 48th St., Long Island City, N. Y.**

PERSONNEL: A. E. Ulmamer, Pres.; W. A. De Lamater, V. Pres. & Secy.; T. F. Hanley, V. Pres. & Treas.; J. J. Buckley, Prod. Mgr.; R. F. Horton, Sales Mgr.; J. Splain, Pur. Dir.

**M. D. HUBBARD SPRING CO.,  
Pontiac, Mich.**

PERSONNEL: J. A. Hubbard, Gen. Mgr.; P. M. Hubbard, Pur. Agt.

**HUGHES TOOL CO., Houston, Tex.**

PERSONNEL: M. E. Boehm, V. Pres. & Gen. Mgr.; C. S. Johnson, Secy. & Treas.; G. S. Richmond, Sales Mgr.; E. R. Cobden, Pur. Agt.; T. M. Mobley, Pers. Dir.; L. E. Garfield, Chief Engr.

**CARL HUSSMAN,  
3001-07 N. Oakley Ave., Chicago, Ill.**

PERSONNEL: C. Hussman, Pres.

**F. C. HUYCK & SONS, KENWOOD MILLS,  
Albany, N. Y.**

PERSONNEL: W. W. Weed, Pres.; J. L. Braman, V. Pres. & Treas.; F. H. Eldridge, V. Pres. & Gen. Mgr.; H. Eldridge, Secy.; J. S. Helcher, Sales Mgr.; G. L. Brown, Pur. Agt.; F. H. Blessing, Pers. Dir.; E. J. Wilson, Chief Engr.

**HY-PRO TOOL CO.,  
476 Mt. Pleasant St., New Bedford,  
Mass.**

PERSONNEL: P. Sweeney, Pres. & Gen. Mgr.; D. D. Davis, V. Pres. & Sales Mgr.; C. H. Wardwell, Treas.; H. Phipard, Pur. Dir. & Adv. Mgr.

**HYATT BEARINGS DIV. OF GENERAL  
MOTORS CORP., Harrison, N. J.**

PERSONNEL: H. O. K. Meister, Gen. Mgr.; H. K. Porter, Sales Mgr.; F. A. Weiss, Pur. Agt.; W. C. Nissen, Pers. Dir.; H. M. Carroll, Adv. Mgr.; O. W. Young, Chief Engr.

**THE HYDRAULIC PRESS MFG. CO.,  
Mount Gilead, O.**

PERSONNEL: H. F. MacMillin, Pres.; P. C. Pockock, V. Pres.; W. C. Batchelor, Secy. & Treas.; H. J. Miller, Sales Mgr.; A. L. Boggs, Pur. Agt.; E. Auld, Pers. Dir.; R. W. Powell, Pub. Dir.; W. Ernst, Dir. Engr.

**HYLAND MACHINE CO., 40 Potomac St.,  
P. O. Box 992, Dayton 5, O.**

PERSONNEL: F. Hyland, Pres.; H. Greth, Gen. Mgr.; R. P. White, Pur. Dir.

## I

**IDEAL CLAMP MFG. CO., INC.,  
435 Liberty Ave., Brooklyn, N. Y.**

PERSONNEL: P. Rauch, Pres.; L. J. Rauch, Treas.

**IDEAL COMMUTATOR DRESSER CO.,  
Park Ave., Sycamore, Ill.**

PERSONNEL: J. W. Becker, Pres.; L. C. Becker, V. Pres.; B. E. Holub, Sales Mgr.; P. F. Froeb, Adv. Mgr.

**ILG ELECTRIC VENTILATING CO.,  
2850 N. Crawford, Chicago, Ill.**

PERSONNEL: J. M. Frank, Pres.; W. H. Rietz, V. Pres.; L. Steinebach, Secy.; P. D. Briggs, Sales Mgr.; C. W. Dexter, Adv. Mgr.; A. G. Sutcliffe, Chief Engr.

**ILLINOIS TESTING LABORATORIES, INC.,  
420 N. La Salle St., Chicago, Ill.**

PERSONNEL: J. A. Obermaier, Pres., Treas., Gen. Mgr. & Chief Engr.; E. Obermaier, V. Pres.; M. J. Rauscher, Secy., Sales Mgr. & Pub. Dir.; J. M. Lajka, Pur. Agt.

**ILLINOIS TOOL WORKS,  
2501 N. Keeler Ave., Chicago 39, Ill.**

PERSONNEL: H. B. Smith, Pres. & Treas.; F. W. England, Exec. V. Pres.; C. L. Johnson, V. Pres. & Secy.; C. J. Irwin, Prod. Mgr.; E. E. Vally, Sales Mgr.; W. R. Smith, Pur. Dir.; J. Tomlin, Pers. Dir.; R. M. Wall, Adv. Mgr.; R. Wicks, Chief Engr.

**THE IMPERIAL BRASS MANUFACTURING  
CO., 1200 W. Harrison St., Chicago, Ill.**

PERSONNEL: F. McNellis, Pres. & Treas.; F. C. Shafer, V. Pres. & Gen. Mgr.; A. Dobrick, V. Pres. & Secy.; J. X. Allman, Sales Mgr. Aviation Div.; W. B. Burnet, Pur. Dir.; E. F. Todd, Adv. Mgr.; R. D. McIntosh, Chief Engr.

**INDEPENDENT IRON WORKS, LTD.,  
821 Pine St., Oakland 7, Calif.**

PERSONNEL: W. G. Meagher, Pres.; H. Gede, Jr., V. Pres.; R. R. Dennis, Secy. & Treas.; K. M. Keegan, Gen. Mgr.; W. Mason, Prod. Mgr.; E. C. Williams, Jr., Sales Mgr.; D. Andersen, Pur. Dir.; D. R. Meagher, Chief Engr.



## Houghton, too, is part of the ground crew!

Maintenance of fighting aircraft involves many processes to which Houghton oils and leathers contribute in no small measure.

With a background of research and experience with petroleum derivatives dating back to 1865, this organization's products are being relied upon by aircraft builders and maintenance men.

Houghton has played a major role in solving the hydraulic packing winterization problem, so that shock struts now operate safely in any climate.

This organization has also pioneered in heat treatment and machining, in corrosion prevention and special lubrication. Maintenance men are invited to write us on any of the products described below.

**E. F. HOUGHTON & CO.**

303 W. LEHIGH AVE., PHILADELPHIA

VIM LEATHER AIRCRAFT PACKINGS — RUST PREVENTIVES — HEAT TREATING  
COMPOUNDS — MACHINING OILS — LUBRICANTS — HYDRAULIC OILS  
CUTTING OILS AND BASES

- INDEPENDENT PNEUMATIC TOOL CO.,**  
600 W. Jackson Blvd., Chicago, Ill.  
PERSONNEL: N. C. Hurley, Pres.; W. A. Nugent, N. C. Hurley, Jr., V. Pres.; J. A. McGuire, Secy.; E. G. Gustafson, Treas.; J. V. Trojan, Sales Mgr.; G. V. Theurer, Pur. Dir.; M. Schultz, Pers. Dir.; C. N. Kirchner, Adv. Mgr.; W. G. Mitchell, Chief Engr.
- INDIANA GEAR WORKS,**  
1458 E. 19th St., Indianapolis, Ind.  
PERSONNEL: L. C. Buchler, Gen. Mgr.; W. A. Groat, Jr., Pur. Agt.; J. A. Hoagland, Pers. Dir.; J. L. Buehler, Chief Engr.
- INDIANA VENEER AND PANEL CO.,**  
Silver St., New Albany, Ind.  
PERSONNEL: E. O. Dulaney, Pres.; F. W. Rucker, V. Pres.; J. B. Shannon, Factory Mgr.; G. A. Williams, Chief Engr.
- INDUSTRIAL ABRASIVES INC.,**  
3724 W. 38th St., Chicago 32, Ill.  
PERSONNEL: L. H. Metzger, Pres. & Gen. Mgr.; M. L. Straus, Jr., Secy. & Treas.; W. B. Muse, Sales Mgr. & Adv. Mgr.; A. Schuller, Pur. Dir.
- INDUSTRIAL GRINDING CO.,**  
6423 McKinley Ave., Los Angeles, Calif.  
PERSONNEL: J. W. Boening, W. E. Miller, Partners; W. J. Phelan, Supt.; M. L. Hannon, Secy.; P. D. Leonis, Pers. Mgr.
- INDUSTRIAL SOUND CONTROL,**  
45 Granby St., Hartford, Conn.  
PERSONNEL: C. W. Lemmerman, Pres.; G. E. Wood, Secy.; C. G. Keirstead, Treas.
- INDUSTRIAL TAPE CORP.,**  
New Brunswick, N. J.  
PERSONNEL: G. F. Smith, Pres.; W. E. Meyers, V. Pres.; J. S. Nicholls, V. Pres. & Gen. Mgr.; J. J. Gibson, Secy.; F. A. Cosgrove, Treas.; J. H. Scherer, Sales Mgr.; W. H. Roberts, Pur. Agt.; D. Simonds, Chief Engr.
- INDUSTRIAL WIRE CLOTH PRODUCTS CORP.,** Fourth & Brush Sts., Wayne, Mich.  
PERSONNEL: F. A. Vollbrecht, Pres. & Gen. Mgr.; I. C. Vollbrecht, Secy.; W. F. Hoffman, Treas.; H. F. Schulte, Sales Mgr.; G. C. Pushelberg, Pur. Agt.; W. L. Smith, Pers. Dir.; M. A. Mieras, Chief Engr.
- INGLEWOOD SHEET METAL WORKS,**  
158 N. La Brea, Inglewood, Calif.  
PERSONNEL: H. Wernik, Pres.; K. Wernik, V. Pres.
- INTERCONTINENT AIRCRAFT CORP.,**  
Miami Springs, Fla.  
PERSONNEL: G. M. Williams, Pres.; W. A. Hayward, V. Pres.-Operations; W. S. Leaycraft, V. Pres. & Treas.; R. E. Brown, Works Mgr.; E. N. Laurance, Factory Supt.; Hill & Knowlton, Pub. Dir.
- INTERCONTINENTAL ENGINEERS, INC.,**  
176 W. Adams St., Chicago 3, Ill.  
PERSONNEL: W. A. Darrah, Pres. & Treas.; R. A. Hastings, V. Pres. & Sales Mgr.; E. B. Jones, V. Pres. & Chief Engr.; L. S. Reilly, Secy.; G. P. Masure, Pur. Dir. & Adv. Mgr.
- INTERNATIONAL FLARE SIGNAL DIV.,**  
(See Kilgore Manufacturing Co.)
- INTERNATIONAL MACHINE TOOL CORP.,**  
1124 W. 21st St., Indianapolis, Ind.  
PERSONNEL: C. R. Feldmann, Pres.; W. J. Hannum, V. Pres. & Gen. Mgr.; J. Hancock, Secy.; G. G. Hathaway, Sales Mgr.; W. L. Hunter, Pur. Agt.
- THE INTERNATIONAL PISTON RING CO.,**  
2401 W. Superior Ave., Cleveland, O.  
PERSONNEL: H. F. Gray, Pres. & Chief Engr.; H. C. Crawford, V. Pres.; W. M. Gray, Secy.; C. Wenzel, Treas.; F. P. Gray, Sales Mgr. & Pub. Dir.; J. Mack, Pur. Agt.
- INTERNATIONAL RESISTANCE CO.,**  
401 N. Broad St., Philadelphia, Pa.  
PERSONNEL: E. Searing, Pres.; H. A. Ehle, V. Pres.; R. N. Shires, Secy.; H. A. Schmidt, Treas.; M. J. Bethany, Pur. Agt.; J. Marsten, Chief Engr.
- INTERNATIONAL SCREW CO.,**  
9444 Roselawn Ave., Detroit, Mich.  
PERSONNEL: W. L. Nelson, Pres. & Gen. Mgr.; W. C. Nelson, V. Pres., Pur. Agt. & Pers. Dir.; L. F. Nelson, Secy. & Treas.; T. Stevens, Sales Mgr.; K. E. Nelson, Chief Engr.
- INTERNATIONAL STACEY CORP.,**  
Columbus, O.  
PERSONNEL: O. M. Havekotte, Pres. & Gen. Mgr.; R. R. Bloss, V. Pres.; G. B. Fenton, Secy.; R. B. McCleery, Treas.; W. F. Barnes, Sales Mgr.; J. T. Dunlap, Pur. Agt.; E. J. Roush, Pers. Dir.; C. R. Athy, Pub. Dir.; L. E. Roelofs, Chief Engr.
- INTERSTATE AIRCRAFT & ENGINEERING CORP.,** 3443 Wilshire Blvd., Los Angeles, Calif.  
PERSONNEL: D. P. Smith, Pres.; W. E. Hirtensteiner, V. Pres.-Production; W. A. Hite, V. Pres.-Engrg.; L. B. Cameron, Secy. & Treas.; J. E. Koster, Pur. Agt.; R. W. Limacher, Pers. Dir.; H. O. Nelson, Pub. Dir.
- INTERSTATE BRAKE TESTING MACHINE CO.,** 1218 Rio Vista Ave., Los Angeles, Calif.  
PERSONNEL: H. W. Langbein, Owner & Gen. Mgr.; D. N. Parks, Sales Mgr.
- INTERSTATE DROP FORGE CO.,**  
4051 N. 27th St., Milwaukee, Wisc.  
PERSONNEL: C. E. Stone, Pres. & Gen. Mgr.; H. C. Osborn, V. Pres.; C. C. Bremer, Secy. & Treas.; J. A. Webber, Chief Engr.
- IRVINGTON VARNISH & INSULATOR CO.,**  
6 Argyle Terrace, Irvington 11, N. J.  
PERSONNEL: A. E. Jones, Pres. & Gen. Mgr.; W. F. Hoffmann, Jr., V. Pres.; F. M. Miller, Secy.; C. Egner, Treas.; D. H. Garrison, Prod. Mgr.; J. J. Connors, Sales Mgr.; K. C. Johnson, Pur. Dir.; J. Pickett, Pers. Dir.; K. A. Lederer, Acting Adv. Mgr.
- ISLIP RADIO MANUFACTURING CORP.,**  
Beech St., Islip, N. Y.  
PERSONNEL: A. E. Theis, Pres.; P. E. Ricketts, V. Pres., Gen. Mgr. & Pers. Dir.; W. A. Wiener, Secy. & Chief Engr.; J. V. Potter, Pur. Dir.

## J

- J. V. W. & CO.,**  
1100 Raymond Blvd., Newark 5, N. J.  
PERSONNEL: C. S. Jones, L. D. Warrander, R. Whatham, G. A. Vaughn, Jr., Partners; R. Whatham, Sales Mgr.; G. A. Vaughn, Jr., Pur. Dir.; C. S. Jones, Pub. Dir.; L. D. Warrander, Chief Engr.

- JACK & HEINTZ, INC.,** Bedford, O.  
PERSONNEL: W. S. Jack, Pres., Gen. Mgr. & Sales Mgr.; R. M. Heintz, V. Pres., Secy. & Chief Engr.; W. R. Jack, V. Pres. & Treas.; W. E. Tabb, Prod. Mgr.; J. S. Zorn, Pur. Dir.; F. L. Schultz, Pers. Dir.; T. Taylor, Pub. Dir. & Adv. Mgr.

**BOMB SHACKLES  
AIR AND FLUID  
VALVES • MANUAL  
AND AUTOMATIC  
GUN CHARGERS  
COWL, WING FLAP  
OPERATORS  
BRAKES  
HYDRAULIC  
PUMPS**

**In addition to  
Aircraft Precision  
Units, Interstate  
builds complete  
planes of its own  
design for the  
U. S. Government**



*Interstate*

**AIRCRAFT AND ENGINEERING CORPORATION**

EXECUTIVE OFFICE: 3443 WILSHIRE BOULEVARD, LOS ANGELES  
PLANTS AT EL SEGUNDO, CALIFORNIA AND DE KALB, ILLINOIS

**JACOEL CABLE SPLICING EQUIPMENT CO.,** 1514 Main St., Buffalo 9, N. Y.  
PERSONNEL: I. Jacoel, Pres.

**JARDUR IMPORT CO.,** 874 Broadway, New York, N. Y.  
PERSONNEL: F. W. Donaldson, Gen. Mgr.; H. H. Clapper, Sales Mgr.; T. J. Waters, Pur. Agt.; C. W. Cromwell, Pub. Dir.; W. W. Smith, Chief Engr.

**JEFFERSON-TRAVIS RADIO MFG. CORP.,** 380 Second Ave., New York, N. Y.  
PERSONNEL: I. M. Felt, Pres. & Treas.; E. Ellinger, Jr., V. Pres. & Secy.; W. C. Hustis, Sales Mgr.; P. Nichols, Pur. Agt.; F. A. Lindley, Chief Engr.

**JESSOP STEEL CO.,** Washington, Pa.  
PERSONNEL: R. E. Emery, Pres.; F. T. H. Youngman, V. Pres. & Treas.; R. J. Murray, Secy.; T. W. Pennington, Sales Mgr.; G. R. Forsberg, Pur. Agt.

**JOHNS-MANVILLE SALES CORP.,** 22 E. 40th St., New York, N. Y.  
PERSONNEL: L. H. Brown, Pres.; J. H. Trent, V. Pres.-Sales; W. S. Hough, Sales Mgr.; N. O. Aeby, Pur. Dir.; H. D. Bates, Pub. Dir.

**THE JOHNSON RUBBER CO.,** Middlefield, O.  
PERSONNEL: S. M. Johnson, Pres.; L. M. Johnson, V. Pres. & Gen. Mgr.; H. G. Johnson, Secy. & Treas.; P. Sperry, Sales Mgr.; R. W. Caslow, Pur. Agt.

**S. C. JOHNSON & SON, INC.,** Racine, Wisc.  
PERSONNEL: H. F. Johnson, Jr., Pres.; C. A. Armstrong, V. Pres.; K. R. Nelson, Secy.; J. R. Ramsey, Treas. & Gen. Mgr.; P. M. Petersen, Sales Mgr.; R. P. Gardiner, Pur. Agt.; S. R. Belden, Pers. Dir.; W. N. Connolly, Pub. Dir.

**JOHNSON TOOL CO., INC.,** 65 Massasoit Ave., East Providence, R. I.  
PERSONNEL: A. E. Johnson, Pres. & Treas.; A. Johnson, V. Pres.; M. S. Millard, Secy.; M. G. Swanson, Gen. Mgr.

**HOWARD B. JONES,** 2460 W. George St., Chicago, Ill.  
PERSONNEL: H. B. Jones, Pres.; H. W. Miller, Prod. Mgr.; W. A. Bockius, Sales Mgr.; B. F. Becker, Pur. Dir.; R. O. Evans, Pers. Dir.; C. W. Nelson, Adv. Mgr.; E. A. Skeppstrom, Chief Engr.

**JONES-DABNEY CO.,** Louisville, Ky.  
PERSONNEL: W. C. Dabney, Pres.; A. W. Bornhauser, V. Pres.; F. H. Volk, Secy. & Treas.; H. C. Reed, Mgr., Aviation Div.; J. C. Cullan, Pur. Agt.

**FRANK E. JONES MACHINERY CORP.,** 1403 Santa Fe Ave., Los Angeles, Calif.  
PERSONNEL: A. S. Jones, V. Pres.; H. W. Jones, Secy. & Treas.

**JONES & LAMSON MACHINE CO.,** Springfield, Vt.  
PERSONNEL: R. E. Flanders, Pres.; K. H. Woolson, V. Pres. & Gen. Mgr.; J. E. Lovely, V. Pres. & Chief Engr.; J. W. Bennett, Secy.; W. D. Woolson, Treas.; J. Lawrence, Prod. Mgr.; J. C. Hebert, Sales Mgr.; E. F. St. Mary, Pur. Dir.; E. L. Huber, Pers. Dir.; J. C. Price, Adv. Mgr.

**JONES MOTROLA SALES CO.,** 432 Fairfield Ave., Stamford, Conn.  
PERSONNEL: C. E. Rees, Pres.; C. F. Thiele, Chief Engr.

**W. B. JONES SPRING CO.,** 124 E. Seventh St., Cincinnati, O.  
PERSONNEL: W. B. Jones, Pres.; A. G. George, Secy.

**JOWEIN INC. AIRCRAFT DIV.,** Jamaica, N. Y.  
PERSONNEL: M. E. Harker, Sr., Exec. V. Pres.; J. Oliviant, Secy., Treas. & Prod. Engr.

**JUSTRITE MFG. CO.,** 2090 Southport Ave., Chicago, Ill.

## K

**THE K D LAMP CO.,** 610 W. Court St., Cincinnati, O.  
PERSONNEL: H. R. Kerans, Pres. & Gen. Mgr.; H. F. Griffin, V. Pres., Sales Mgr. & Pub. Dir.; C. C. Clark, Secy., Treas. & Pers. Dir.; A. B. Dettmer, Pur. Agt.; W. Trautner, Chief Engr.

**THE KAWNEER CO.,** Niles, Mich.  
PERSONNEL: L. J. Plym, Pres.; F. R. Eaglesfield, V. Pres. & Sales Mgr.; E. M. Bigelow, Secy.; H. W. Zimmer, Treas.; A. M. Simpson, Gen. Mgr.; E. C. Witwer, Pur. Agt.; G. Horst, Pers. Dir.; J. H. Taylor, Jr., Pub. Dir.; K. Knott, Chief Engr.

**KELITE PRODUCTS, INC.,** 909 E. 60th St., Los Angeles, Calif.  
PERSONNEL: L. C. Sorensen, Pres. & Gen. Mgr.; H. L. Smith, V. Pres.; H. Burrell, Secy. & Treas.; R. Medanieh, Sales Mgr.; F. W. Frisenfeldt, Pur. Agt. & Pub. Dir.; J. F. Hart, Chief Chemist.

**KELLETT AUTOGIRO CORP.,** 58th & Grays Ave., Philadelphia, Pa.  
PERSONNEL: W. W. Kellett, Pres.; R. G. Kellett, Exec. V. Pres., Sales Mgr. & Pub. Dir.; R. H. Prewitt, V. Pres.-Engrg.; W. F. Palmer, Secy. & Treas.; S. P. Lyon, Gen. Mgr.; J. E. Robertson, Pur. Agt.; A. W. Hendrickson, Pers. Dir.

**THE KELLEY-KOETT MFG. CO.,** 212 W. Fourth St., Covington, Ky.  
PERSONNEL: A. H. Feibel, Pres. & Gen. Mgr.; L. Stork, Prod. Mgr.; J. H. Bell, Sales Mgr.; J. Klumpe, Pur. Dir.; L. Bohn, Adv. Mgr.; D. Sussin, Chief Engr.

**KELLOGG SWITCHBOARD & SUPPLY CO.,** 6650 S. Cicero Ave., Chicago 38, Ill.  
PERSONNEL: J. G. Kellogg, Pres.; J. H. Kellogg, Exec. V. Pres. & Secy.; H. C. McCluskey, Treas.; C. D. Manning, Sales Mgr.; J. Geiger, Pur. Dir.; J. A. Petrick, Pers. Dir.; R. C. Krueger, Pub. Dir. & Adv. Mgr.; R. M. Kalb, Chief Engr.

**KELSEY HAYES WHEEL CO.,** 3600 Military Ave., Detroit, Mich.  
PERSONNEL: G. W. Kennedy, Pres. & Gen. Mgr.; M. S. P. Williams, V. Pres. & Pub. Dir.; L. C. Brooks, Secy.; L. W. Downie, Treas.; J. M. Kerr, Sales Mgr.; J. H. Murphy, Pur. Agt.; P. Denzig, Pers. Dir.; C. W. Sinclair, Chief Engr.

**KENDALL REFINING CO.,** Bradford, Pa.  
PERSONNEL: J. B. Fisher, Pres.; J. H. Bovaird, V. Pres.; S. J. Brill, Secy.; O. Koch, Treas.; H. V. Smith, Prod. Mgr.; T. O. Grisell, Sales Mgr.; F. Wodrich, Jr., Pur. Dir.; W. M. Magee, Pers. Dir.; W. T. Moffatt, Adv. Mgr.

# Ingredients for Victory!

Precision-made aircraft parts, destined to play havoc with Hitler and rain hell on the streets of Tokio, are Hyland's contribution to united effort . . . and the very ingredients of Victory! Subcontractors to the majority of aircraft companies, the Hyland Machine Company rigidly enforces all Army and Navy specifications. And each Hyland product is made available as fast as conditions will permit to speed Axis down-fall.

Address inquiries: Hyland Machine Co., Dayton, O. Export Representative: Aviation Equipment & Export, Inc., 25 Beaver St., New York.



*Hyland employees are proud of this flag. It displays the united loyalty of every worker.*

**HYLAND MACHINE COMPANY**  
DAYTON, OHIO





**KENNAMETAL INC.,**

1000 Lloyd Ave., Latrobe, Pa.  
 PERSONNEL: P. M. McKenna, Pres.; A. G. McKenna, D. C. McKenna, V. Pres.; R. M. Zacharias, Secy.; G. T. Kearns, Treas.; F. W. Pennington, Adv. Mgr.; W. L. Kennicott, Chief Engr.

**KENNEDY NAME PLATE CO.,**

4501-09 Pacific Blvd., Los Angeles, Calif.  
 PERSONNEL: J. W. Hayek, Pres. & Chief Engr.; D. R. Koelling, V. Pres. & Pur. Agt.; W. J. Kennedy, Secy., Treas., Sales Mgr. & Pub. Dir.; A. Van Selow, Pers. Dir.

**F. C. KENT CO.,**

64-72 Howard St., Irvington, N. J.  
 PERSONNEL: F. C. Kent, Pres.; W. Grunhof, Jr., V. Pres. & Sales Mgr.; H. E. Ferris, Secy.; T. H. McGechin, Pur. Agt.; W. Binszus, Chief Engr.

**KENT-MOORE ORGANIZATION, INC.,**

General Motors Research Bldg., Detroit, Mich.  
 PERSONNEL: W. A. Kent, Pres.; J. E. Moore, V. Pres.; F. C. Bowles, Secy. & Treas.; H. L. Faust, Sales Mgr.; A. Bacon, Pur. Agt.; S. M. Graham, Chief Engr.

**KENT-OWENS MACHINE CO.,**

958 Wall St., Toledo, O.  
 PERSONNEL: W. J. Donkel, Pres.; W. J. Rohr, V. Pres.; R. F. Wieland, Secy. & Treas.; E. W. Donkel, Gen. Mgr.; H. G. Stevens, Prod. Mgr.; E. E. Burke, Sales Mgr. & Adv. Mgr.; J. J. Jackson, Pur. Dir.; A. B. Bok, Chief Engr.

**KENYON INSTRUMENT CO., INC.,**

1345 New York Ave., Huntington, N. Y.  
 PERSONNEL: A. T. Newell, Pres., Gen. Mgr. & Chief Engr.; H. R. Talbot, V. Pres., Treas. & Pur. Dir.; D. W. Newell, Secy.; T. S. Hall, Jr., Sales Mgr. Aircraft Div.; A. T. Valentine, Sales Mgr. Marine Div., Pers. Dir., Pub. Dir. & Adv. Mgr.

**KENYON TRANSFORMER CO., INC.,**

840 Barry St., New York, N. Y.  
 PERSONNEL: F. P. Kenyon, Pres.; F. R. Kenyon, Gen. Mgr.; R. B. Shimer, Chief Engr.

**KESTER SOLDER CO.,**

4201 Wrightwood Ave., Chicago, Ill.  
 PERSONNEL: F. C. Engelhart, Pres. & Treas.; E. H. Williams, Secy.; P. C. Ripley, Sales Mgr.; G. E. Fischer, Pur. Agt.; H. C. Prange, Pers. Dir.

**KEYES FIBRE CO., Waterville, Me.**

PERSONNEL: D. S. Brigham, Pres.; L. A. Pierce, Secy.; S. Bisbee, Treas.; W. E. Parsons, Gen. Mgr.; R. H. Cutting, Asst. Treas. & Pur. Dir.; R. O. Brown, Pers. Dir.; W. H. Randall, Chief Engr.

**KEYSTONE AIRCRAFT PRODUCTS, INC.,**

Blackman & Race Sts., W. Pittston, Pa.  
 PERSONNEL: P. L. Gross, Pres.; C. H. Hoffner, V. Pres., Secy. & Gen. Mgr.; W. H. Croughn, Treas.; J. G. Racavich, Prod. Mgr.; S. N. Darby, Sales Mgr.; J. Serling, Pers. Dir.; L. B. Bingaman, Chief Engr.

**KEYSTONE CARBON CO., INC.,**

St. Marys, Pa.  
 PERSONNEL: B. R. Reuscher, Pres. & Gen. Mgr.; F. A. Krellner, V. Pres., Sales Mgr. & Adv. Mgr.; C. N. Klausman, Secy. & Treas.; A. F. Meyer, Prod. Mgr.; R. Knonenwetter, Pur. Dir.; H. P. Sorg, Pers. Dir.; R. R. Hoffman, Chief Engr.

**KEYSTONE TOOL & SUPPLY CO.,**

7720 Maie Ave., Los Angeles, Calif.  
 PERSONNEL: W. E. Smith, Pres.; E. D. Barry, Gen. Mgr.; G. Whitaker, Sales Mgr.; G. Andersen, Pur. Agt.; O. Felt, Pers. Dir.

**WALTER KIDDE & CO., INC.,**

184 Main St., Belleville, N. J.  
 PERSONNEL: J. F. Kidde, Pres.; C. L. Griffin, Sales Mgr.; N. Vuyosevich, Pur. Dir.; G. Ives, Adv. Mgr.

**KIEKHAEFER CORP.,**

Western Ave., Cedarburg, Wisc.  
 PERSONNEL: A. C. Kiekhaefer, Pres.; E. C. Kiekhaefer, V. Pres. & Gen. Mgr.; W. Blank, Secy.; A. Horn, Treas.; J. F. Kellner, Asst. Treas.; W. J. Moerschel, Asst. Gen. Mgr.; L. Lohmann, Prod. Mgr.; H. Voelz, Pur. Dir.; H. F. Schmidt, Chief Engr.

**KILGEN AIRCRAFT, DIV. OF THE KILGEN ORGAN CO., 4443 Cook Ave., St. Louis 13, Mo.**

PERSONNEL: E. R. Kilgen, Pres. & Gen. Mgr.; M. Hess, V. Pres. & Chief Engr.; J. Maruska, Secy. & Asst. Treas.; P. J. Garvey, Prod. Mgr. & Sales Mgr.; J. Weber, Pur. Dir. & Pers. Dir.; M. Bronson, Pub. Dir. & Adv. Mgr.; G. McCandless, Asst. Engr.

**THE KILGORE MANUFACTURING CO., INTERNATIONAL FLARE-SIGNAL DIV., Tipp City, O.**

PERSONNEL: H. B. Watkins, Pres. & Treas.; A. F. Hubbard, V. Pres. & Gen. Mgr.; D. L. Reed, Secy.; R. D. Wiley, Prod. Mgr.; C. H. Moser, Pur. Dir.; J. F. Mains, Pers. Dir.; H. W. Houser, Chief Engr.

**KING PLASTICS CORP.,**

101 E. Speer Blvd., Denver 3, Colo.  
 PERSONNEL: E. K. Krueger, Pres. & Gen. Mgr.; J. C. Gadd, V. Pres.; D. Ormsbee, Secy. & Treas.; R. P. McClung, Prod. Mgr.; J. C. Speight, Sales Mgr.; D. W. Cluff, Pur. Dir.; W. F. Turner, Chief Engr.

**KING-SEELEY CORP., Ann Arbor, Mich.**

PERSONNEL: J. Airey, Pres. & Gen. Mgr.; W. E. Bandemer, V. Pres. & Sales Mgr.; K. M. Conklin, Secy.; D. T. Warner, Treas. & Pur. Agt.; L. E. Quinn, Pers. Dir.; R. C. Darnell, Chief Engr.

**KINGSBURY MACHINE TOOL CORP.,**

Keene, N. H.  
 PERSONNEL: E. J. Kingsbury, Pres.; G. Swahnberg, V. Pres.; E. Hagland, Pur. Agt.; B. N. Foster, Chief Engr.

**KLEMM AUTOMOTIVE PRODUCTS CO.,**

1718 N. Damen Ave., Chicago, Ill.  
 PERSONNEL: E. R. Klemm, Jr., Pres., Sales Mgr. & Chief Engr.; P. E. Klemm, Secy., Treas. & Pur. Agt.

**KLIEGL BROS. UNIVERSAL ELECTRIC STAGE LIGHTING CO., INC., 321 W. 50th St., New York, N. Y.**

PERSONNEL: J. H. Kliegl, Pres.; H. A. Kliegl, V. Pres.; F. Bliss, Secy. & Sales Mgr.; J. Kliegl, Prod. Mgr.; H. Fisher, Pur. Dir.; A. McGregor, Adv. Mgr.

**W. B. KNIGHT MACHINERY CO.,**

3920 W. Pine Blvd., St. Louis, Mo.  
 PERSONNEL: W. B. Knight, Pres.; H. E. Knight, V. Pres.; C. W. Knight, Secy. & Treas.

**THE KNIGHT SCREW PRODUCTS CO.,**

7401 Lyndon, Detroit, Mich.  
 PERSONNEL: W. C. Knight, Pres. & Gen. Mgr.; J. R. Adams, V. Pres.; F. F. Bastien, Secy., Treas. & Pur. Agt.; A. B. Edwards, Pers. Dir.; C. E. Barr, Chief Engr.

# FLARES

## LIGHTING THE PATH TO VICTORY

Our Air, Naval and Ground Forces all require the various types of Flares and Signals we have produced, and continue to produce, for the war effort.

Quantity production has only increased the degree of skill and control necessary to meet the high standards of dependable performance with which the name "INTERNATIONAL" has always been synonymous in the field of Military Pyrotechnics.

Expanded facilities permit continuing services to commercial aviation if such requirements are supported by adequate priority ratings.



# INTERNATIONAL FLARE-SIGNAL DIV.

*of THE KILGORE MFG. CO. Tipp City, Ohio*

**KNU-UISE, INC.**

2200 Eighth St., Detroit 16, Mich.

PERSONNEL: J. A. Herrington, Pres. & Treas.; L. H. Portnoy, V. Pres. & Secy.; M. F. Barkus, Gen. Mgr.; A. Johnson, Prod. Mgr.; J. P. Kowalik, Sales Mgr.; F. C. Gumpper, Pur. Dir.; C. Shower, Adv. Mgr.; G. Vogel, Chief Engr.

**GEORGE KOCH SONS, INC.,** Evansville, Ind.

PERSONNEL: A. C. Koch, Pres.; G. W. Koch, V. Pres.; R. L. Koch, Secy. & Treas.; L. J. Koch, Gen. Mgr.; C. Robb, Sales Mgr.; E. E. Lyons, Pur. Agt.; G. A. Koch, Pers. Dir.; H. F. Cooper, Pub. Dir.; F. L. Elliott, Chief Engr.

**KOEHLER AIRCRAFT PRODUCTS CO.,**

814 Vermont Ave., Dayton, O.

PERSONNEL: G. J. Koehler, Pres. & Gen. Mgr.; G. T. Koehler, V. Pres. & Chief Engr.; A. W. Kuhner, Sales Mgr. & Pur. Agt.

**KOLD-HOLD MANUFACTURING CO.,**

424 N. Grand Ave., Lansing, Mich.

PERSONNEL: J. R. Tranter, Pres. & Gen. Mgr.; E. A. Thiele, V. Pres.; C. H. Reynolds, Secy. & Treas.; F. A. Haag, Sales Mgr.; M. M. Brown, Pur. Agt.; L. S. Worthington, Pub. Dir.; R. H. Swart, Chief Engr.

**KOLLSMAN INSTRUMENT DIV. OF**

SQUARE D CO., 80-08 45th Ave., Elmhurst, N. Y.

PERSONNEL: F. W. Magin, Pres.; P. Kollsman, V. Pres. & Chief Engr.; G. R. Adolph, Asst. Secy.; L. Bolster, Asst. Treas.; V. Carbonara, Gen. Mgr.; W. C. Bonn, Sales Mgr.; J. Goodrich, Pur. Agt.; P. S. Knowles, Pers. Dir.; J. C. Carr, Pub. Dir.

**E. KONIGSLOW STAMPING & TOOL CO.,**

3401 Vega Ave., Cleveland, O.

PERSONNEL: H. F. Stuhr, Pres.; W. F. Schmidt, V. Pres. & Gen. Mgr.; L. A. Walter, Secy.

**KOPP GLASS, INC.,** Swissvale, Pa.

PERSONNEL: C. H. Curry, Pres. & Treas.; C. J. Huot, V. Pres. & Gen. Mgr.; G. D. Hammond, Secy.; H. F. Thorne, Sales Mgr.

**KOPPERS CO., AMERICAN HAMMERED**

PISTON RING DIV., Bush &amp; Hamburg Sts., Baltimore 30, Md.

PERSONNEL: A. W. Morton, V. Pres. & Gen. Mgr.; R. D. Phippen, Asst. Secy. & Asst. Treas.; E. S. Freeman, Jr., Works Mgr.; T. L. Ford, Sales Mgr.-Automotive Div.; J. A. Worthington, Sales Mgr.-Industrial Div.; L. Palmer, Pur. Dir.; J. E. Weer, Pers. Dir.; P. E. Chamberlain, Pub. Dir.; E. Stead, Chief Engr.

**KREMBS & CO.,**

669 W. Ohio St., Chicago, Ill.

PERSONNEL: O. M. Krembs, Prop.

**KROPP FORGE AVIATION CO.,**

5301 W. Roosevelt Rd., Chicago, Ill.

PERSONNEL: R. A. Kropp, Pres.; R. B. Kropp, V. Pres. & Treas.; R. T. O'Keefe, V. Pres.; C. Johnson, Secy.; J. E. Sweeney, Works Mgr.; J. H. Lund, Sales Mgr.; L. W. Kreicker, Adv. Mgr.

**KULKA ELECTRIC MANUFACTURING CO.,**

Inc., 30 South St., Mount Vernon, N. Y.

PERSONNEL: E. R. Kulka, Pres., Gen. Mgr. & Chief Engr.; W. Kulka, Secy., Treas. & Pur. Dir.; P. Pane, Prod. Mgr.; L. Slubin, Sales Mgr.; L. Blehart, Pub. Dir. & Adv. Mgr.

**L****L & J PRESS CORP.,**

Sterling &amp; Ren Sts., Elkhart, Ind.

PERSONNEL: D. R. Grossman, Pres. & Gen. Mgr.; M. B. Lockwood, Pur. Dir.; A. D. Hall, Chief Engr.

**L & R MANUFACTURING CO.,**

54-56 Clinton St., Newark, N. J.

PERSONNEL: M. A. Lazarus, Pres.; M. Steinhardt, Pur. Agt. & Pub. Dir.

**THE LACKAWANNA LEATHER CO.,**

740 Grand Ave., Hackettstown, N. J.

PERSONNEL: D. S. Good, Pres. & Gen. Mgr.; D. H. McCree, V. Pres. & Sales Mgr.; C. F. Good, Secy.; J. D. Woodward, Treas.

**THE LAIDLAW CO., INC.,**

16 W. 60th St., New York, N. Y.

PERSONNEL: A. P. Laidlaw, Pres.

**LAISTER KAUFFMANN AIRCRAFT CORP.,**

Administrative Office: 6376 Clayton Rd., St. Louis 17, Mo.

Plant: 5660 Oakland, St. Louis 10, Mo.

PERSONNEL: J. W. Laister, Pres. & Gen. Mgr.; M. N. Whitehead, V. Pres., Pub. Dir. & Adv. Mgr.; J. R. Kauffmann, Secy. & Treas.; J. Nowak, Prod. Mgr.; W. F. Nesbit, Sales Mgr.; F. R. Kaiser, Dir. of Sub-Contracting; F. Lerew, Pers. Mgr.; R. N. Chapman, Chief Engr.

**LAKE ERIE ENGINEERING CORP.,**

Box 68 Kenmore Station, Buffalo, N. Y.

PERSONNEL: R. E. Dillon, Pres. & Gen. Mgr.; H. D. Thweatt, Sales Mgr.

**LAMINATED SHIM CO., INC.,**

Glenbrook, Conn.

PERSONNEL: C. N. Aborn, Pres.; E. B. Nisbet, V. Pres.; R. Seipt, Sales Mgr.; O. C. Jones, Pub. Dir.

**LAMSON CORP.,** Syracuse, N. Y.

PERSONNEL: C. F. Dietz, Pres.; F. D. Weeks, V. Pres. & Treas.; R. I. Hicks, V. Pres. & Sales Mgr.; B. Skelton, Pur. Agt.; L. F. Perkins, Pers. Dir.; C. S. Jennings, Pub. Dir.; H. C. Keller, Engr. Mgr.

**THE LANDERS CORP.,** Toledo, O.

PERSONNEL: R. G. Landers, Pres.; J. P. Howland, Secy.; P. E. Roper, Treas.; C. M. Keiser, Sales Mgr.; J. C. Siegmann, Pur. Agt.; W. Baker, Chief Engr.

**LANDIS MACHINE CO.,** Waynesboro, Pa.

PERSONNEL: C. N. Kirkpatrick, Pres. & Gen. Mgr.; G. M. Stickell, V. Pres. & Sales Mgr.; J. H. Elliott, Secy. & Pur. Agt.; W. C. Wertz, Treas.; H. L. Steck, Pers. Dir.; M. B. Henneberger, Pub. Dir.; C. W. Hopkins, Chief Engr.

**LANE WELLS CO.,**

5610 S. Soto St., Los Angeles, Calif.

PERSONNEL: R. S. Durkee, Pres.; M. E. Montrose, V. Pres., Sales Mgr. & Pub. Dir.; B. G. Peters, Secy.; R. W. Keener, Pur. Dir.; R. M. Otis, Chief Engr.

**LANGELIER MANUFACTURING CO.,**

Elmwood Post Office, Providence, R. I.

PERSONNEL: H. K. Allard, Pres.; A. F. Ward, Gen. Mgr.; L. Wright, Prod. Mgr.; R. Kaminski, Pur. Dir.; W. E. Covill, Chief Engr.

# KENNAMETAL CARBIDE TOOLS



★An effective aid to the aircraft industries in putting planes in the air, and keeping them there, has been the distinctive performance of KENNAMETAL steel-cutting carbide tools. By boring, turning, facing, and milling steel faster and more accurately, these tools have achieved the reputation for being superior cemented carbides.

Actual shop records show that KENNAMETAL milling cutters, for example, have increased the production of airplane parts as much as 500%.

The strength and hardness of KENNAMETAL carbide tips are combined with well-designed, shock-resistant steel or cast iron bodies to form these highly efficient KENNAMETAL-tipped milling cutters.

For further information on KENNAMETAL carbide tools, request our new general Catalog 43-C. It covers in detail such problems as style and grade selection, correct procedure for brazing tips to shanks, and proper tool care.

**KENNAMETAL**

**KENNAMETAL Inc.**

373 LLOYD AVE.  
LATROBE, PA.

**SUPERIOR CEMENTED CARBIDES**



Trade Mark Reg. U. S. Pat. Off.

**LANGLEY CORP.,**

660 Second Ave., San Diego 1, Calif.  
 PERSONNEL: W. Crow, Pres.; A. G. Brown, V. Pres. & Treas.; W. R. Jackson, V. Pres. & Secy.; E. G. Stockton, Pur. Dir.; F. M. Casto, Adv. Mgr.

**LANSING STAMPING CO.,** Lansing 2, Mich.**LASALCO INC.,**

2818-38 LaSalle St., St. Louis 4, Mo.  
 PERSONNEL: B. G. Daw, Pres. & Treas.; H. J. Struckhoff, V. Pres. & Sales Mgr.; C. H. Pinkerton, Secy.; J. C. Bessonette, Pur. Dir.; N. K. House, Chief Engr.

**LAUXITE CORP.,**

116 S. Niagara St., Lockport, N. Y.  
 PERSONNEL: E. H. Merritt, V. Pres.; C. F. Few, Asst. Secy.; J. W. Miller, Operations Dir.; C. F. Van Epps, Technical Dir.

**LAWRANCE AERONAUTICAL CORP.,**

N. Stiles St., Linden, N. J.  
 PERSONNEL: C. L. Lawrence, Ch. of Board; R. Burnstan, Pres. & Gen. Mgr.; A. Marshall, V. Pres.; A. E. Ward, V. Pres. & Treas.; F. Stokes, Secy.; H. H. Wooden, Controller & Asst. Secy.; A. Unsworth, Pers. Dir.

**LEA MANUFACTURING CO.,**

Waterbury, Conn.

**H. LEACH MACHINERY CO.,**

387 Charles St., Providence, R. I.  
 PERSONNEL: M. Leach, Pres. & Gen. Mgr.; H. Leach, Treas.; J. H. Goodman, Sales Mgr.

**LEACH RELAY CO., INC.,**

5915-27 Avalon Blvd., Los Angeles 3, Calif.  
 PERSONNEL: F. P. Hornaday, Pres.; E. K. Neale, V. Pres.; J. S. Edwards, Secy. & Treas.; L. E. Baldrige, Pur. Agt.

**DAVE LEAHY CO.,**

612 W. 18th St., Los Angeles, Calif.  
 PERSONNEL: D. Leahy, Pres.

**LEAR AVIA, INC.,** Piqua, O.

PERSONNEL: W. P. Lear, Pres.; T. S. Harris, V. Pres.; H. C. Morrison, Secy. & Treas.; C. E. Mead, Gen. Mgr.; S. Nesbitt, Sales Mgr. & Pub. Dir.; G. Storar, Sr., Pur. Agt.; E. B. Archibald, Pers. Dir.; R. M. Mack, M. Harges, Chief Engrs.

**THE R. K. LeBLOND MACHINE TOOL CO.,**

Madison & Edwards Rds., Cincinnati, O.  
 PERSONNEL: R. E. LeBlond, Pres. & Gen. Mgr.; W. F. Groene, V. Pres. & Chief Engr.; H. C. Picrle, Secy. & Sales Mgr.; E. G. Schultz, Treas.; W. McK. Reis, Pur. Agt.; W. L. Rybolt, Pub. Dir.

**THE H. D. LEE MERCANTILE CO.,**

20th & Wyandotte, Kansas City, Mo.  
 PERSONNEL: R. B. Caywood, Pres.; B. E. Kinney, V. Pres.; C. A. Reynolds, V. Pres. & Sales Mgr.; J. M. Mitchell, Secy.; F. C. Bacholdt, Treas.; A. D. McCubbin, Pur. Agt.

**THE LEECE-NEVILLE CO.,**

5363 Hamilton Ave., Cleveland 14, O.  
 PERSONNEL: B. M. Leece, Pres. & Treas.; P. H. Neville, V. Pres.; J. P. Johnston, Secy.; K. C. Gano, Sales Mgr.; D. M. Evans, Pur. Dir.; S. F. Stewart, Chief Engr.

**LEEDS & NORTHRUP CO.,**

4970 Stenton Ave., Philadelphia 44, Pa.  
 PERSONNEL: C. S. Redding, Pres.; C. R. Cary, V. Pres.; D. H. Schultz, Secy. & Treas.; P. H. Coley, Factory Mgr.; G. W. Tall, Sales Mgr.; L. Teker, Pur. Dir.; R. W. Johnson, Pers. Dir.; L. R. Garretson, Adv. Mgr.; J. W. Harsch, Chief Engr.

**THE LEES-BRADNER CO.,** W. 121st St. & Elmwood Ave., Cleveland, O.

PERSONNEL: H. T. Bradner, Pres.; C. H. Schurr, V. Pres.; G. H. Bradner, Secy.; J. A. Bradner, Treas. & Sales Mgr.; J. A. Berger, Pur. Agt.; H. C. Warner, Chief Engr.

**LEHMANN MACHINE CO.,**

3560 Chouteau Ave., St. Louis, Mo.  
 PERSONNEL: F. H. Niehaus, Pres.; L. A. Carter, Secy. & Chief Engr.; E. J. Nestor, Pur. Agt.

**LELAND ELECTRIC CO., INC.,**

1501 Webster St., Dayton, O.  
 PERSONNEL: T. B. Fordham, Pres.; W. F. Lisman, V. Pres. & Gen. Mgr.; E. B. George, V. Pres. & Chief Engr.; J. B. Clark, Secy. & Treas.; J. H. Sampson, Works Mgr.; P. D. Dale, Sales Mgr., Pub. Dir. & Adv. Mgr.; T. E. Dimke, Pur. Dir.; H. Curtis, Pers. Dir.

**LEMPCO PRODUCTS, INC.,** Bedford, O.

PERSONNEL: J. F. Strand, Pres.; J. Y. Blazek, V. Pres.; P. F. Hronck, Secy. & Treas.; J. S. Longdon, Sales Mgr.; J. H. Gulick, Pur. Agt.; O. T. Hillschafer, Pers. Dir.; V. Roy, Chief Engr.

**LESLIE WELDING CO.,**

2943 Carroll Ave., Chicago, Ill.  
 PERSONNEL: F. H. Leslie, Prop.

**CHAS. F. L'HOMMEDIEU & SONS CO.,**

4521 Ogden Ave., Chicago, Ill.  
 PERSONNEL: A. W. L'Hommedieu, Pres.; S. L. Cole, V. Pres. & Sales Mgr.; F. C. Stone, Secy.; R. W. Cuthbert, Treas.; C. B. Bennett, Chief Engr.

**LIBBEY-OWENS-FORD GLASS CO.,**

Nicholas Bldg., Toledo, O.  
 PERSONNEL: J. D. Biggers, Pres.; D. H. Goodwillie, Exec. V. Pres. & Gen. Mgr.; H. H. Baker, Secy.; R. H. Taylor, Treas.; G. P. MacNichol, Jr., Sales Mgr.; J. C. Diehl, Pur. Agt.; A. C. Keller, Pers. Dir.; R. W. Winslow, Pub. Dir.; J. L. Drake, Chief Engr.

**LIBERTY AIRCRAFT PRODUCTS CORP.,**

Farmingdale, N. Y.  
 PERSONNEL: J. D. Simon, Pres.; G. H. Hauser, V. Pres.; W. G. Holman, Secy. & Treas.; E. A. Matzen, Pur. Dir.; H. Prime, Pers. Dir.; W. Ochse, Chief Engr.

**LIBERTY MOTORS & ENGINEERING**

**CORP.,** 922 Park Ave., Baltimore 1, Md.  
 PERSONNEL: R. B. Livie, Pres.; C. E. Nolan, V. Pres.; C. W. Brand, Jr., Secy.; V. C. Mahony, Treas.; R. Semmes, Sales Mgr.; W. P. Buel, Pur. Dir.; H. S. Reed, Pers. Dir.; A. Easton, Chief Engr.

**THE LINCOLN ELECTRIC CO.,**

12818 Coit Rd., Cleveland, O.  
 PERSONNEL: J. F. Lincoln, Pres.; C. M. Taylor, V. Pres. & Sales Mgr.; A. F. Davis, Secy.; G. W. Hale, Pur. Agt.; G. G. Landis, Chief Engr.

**LINCOLN ENGINEERING CO.,**

5701 Natural Bridge Ave., St. Louis 20, Mo.  
 PERSONNEL: A. P. Fox, Pres.; J. Kludt, V. Pres.-Prod.; F. Holmes, V. Pres. & Gen. Sales Mgr.; T. V. Picraux, Prod. Mgr.; J. L. Carmichael, Sales Mgr.; D. K. Howell, Jr., Pur. Dir.; R. W. Thomas, Pers. Dir.; W. B. Gordon, Pub. Dir. & Adv. Mgr.; L. C. Rotter, Chief Engr.

**LINCOLN-SCHLUETER FLOOR MACHIN-**

**ERY CO.,** 512-532 S. Peoria St., Chicago 7, Ill.

PERSONNEL: G. A. Schlueter-Ehle, Pres.; H. P. Ehle, V. Pres. & Gen. Mgr.; A. R. Foster, Secy.; F. N. Schlau, Prod. Mgr.; L. C. Johnson, Sales Mgr.; E. J. Zajac, Pur. Dir.; J. A. Backlund, Chief Engr.

*Specify* **LEECE-NEVILLE**

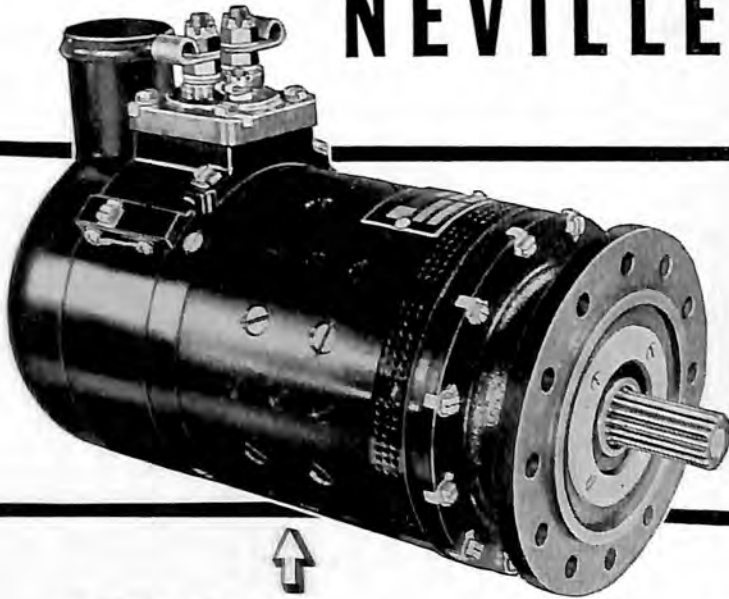

**GENERATORS**

Electrical, D.C. Engine driven. For battery charging. Voltage regulated. All capacities and speed ranges. Both rotations.

**MOTORS**

Electrical, D.C. Clock and anti-clock rotation. Reversible. All voltages. For driving pumps.

**VOLTAGE REGULATORS**

Electrical, D.C. For D.C. generators. All voltages. Hold voltage to plus or minus two percent. Vibrator and carbon pile types.

**SWITCH RELAYS**

Electrical, D.C. All voltages and capacities. Act as automatic switch between generator and battery.

**THE LEECE-NEVILLE CO.**  
**CLEVELAND, OHIO, U. S. A.**



**LINEAR PACKING & RUBBER CO., INC.,**  
State Road & Levick St., Tacony, Philadelphia, Pa.

PERSONNEL: A. W. Swartz, Pres.; F. A. Lewis, V. Pres. & Sales Mgr.; W. C. Fisler, Secy.; W. Z. Funk, Treas.; P. A. Swartz, Pur. Dir.; G. Lorentz, Pers. Dir.; C. C. Ryden, Chief Engr.

**LINK AVIATION DEVICES, INC.,**  
Binghamton, N. Y.

PERSONNEL: E. A. Link, Pres.; G. T. Link, V. Pres. & Treas.; G. Lowkrantz, V. Pres. & Chief Engr.; M. C. Link, Secy.; F. A. Spencer, Gen. Mgr.; R. W. McPherson, Pur. Agt.; R. R. Douglass, Pers. Dir.

**LINK-BELT CO.,**

307 N. Michigan Ave., Chicago 1, Ill.  
PERSONNEL: W. C. Carter, Pres.; E. J. Burnell, E. L. Berry, R. F. Bergmann, V. Pres.; H. E. Kellogg, Secy. & Treas.; J. S. Holl, Adv. Mgr.

**DAVID LINZER & SONS, INC.,**

10-20 Astor Pl., New York, N. Y.  
PERSONNEL: Aaron Linzer, Pres.; S. Linzer, V. Pres.; Abraham Linzer, Secy. & Treas.; V. Paccione, Prod. Mgr.; R. Santer, Chief Engr.

**LIPE-ROLLWAY CORP.,**

208 S. Geddes St., Syracuse 1, N. Y.  
PERSONNEL: H. F. Hodgkins, Pres.; J. D. Williams, V. Pres. & Gen. Mgr.; S. F. Hancock, Secy.; J. S. Ogg, Treas.; G. E. Colbert, Prod. Mgr.; R. S. Russell, Sales Mgr.; J. E. Edmonds, Pur. Dir.; H. B. Smith, Pers. Dir.; P. H. Spittle, Pub. Dir. & Adv. Mgr.; E. R. Fish, Machine Tool Engr.; C. B. Spase, Clutch Engr.

**THE LIQUIDOMETER CORP.,**

Skillman Ave. & 36th St., Long Island City, N. Y.  
PERSONNEL: C. A. deGiers, Pres. & Gen. Mgr.; H. T. Cullinan, V. Pres., Sales Mgr. & Adv. Mgr.; H. A. Kurowski, Secy. & Treas.; R. H. Hogan, Pur. Dir.; A. Wickesser, Chief Engr.

**LISLE CORP., Clarinda, Ia.**

PERSONNEL: C. V. Lisle, Pres. & Gen. Mgr.; J. R. Arthur, V. Pres.; T. E. Brooks, Secy. & Chief Engr.; A. A. Cambre, Treas. & Sales Mgr.; E. G. Thompson, Pur. Agt.

**LISTO PENCIL CORP., Alameda, Calif.**

PERSONNEL: C. E. Wehn, Pres. & Gen. Mgr.; A. S. Cooper, V. Pres.; R. F. Oldershaw, Secy. & Pur. Agt.; I. M. Stuart, Treas.; D. G. Stuart, Sales Mgr. & Pub. Dir.

**LITE MFG. CO.,**

101 W. 21st St., New York, N. Y.  
PERSONNEL: Aleck Leitman, Aaron Leitman, J. Gurwin, Partners; J. Gurwin, Gen. Mgr. & Sales Mgr.; B. D. Shear, Pur. Agt.

**LITTELFUSE, INC.,**

4757 Ravenswood Ave., Chicago 40, Ill.  
PERSONNEL: E. V. Sundt, Pres.; B. M. Kollath, V. Pres.-Plants; G. E. Spates, V. Pres. & Gen. Mgr.; T. M. Blake, Secy. & Treas.; G. F. Taft, Plant Supt.; J. Hughes, Prod. Mgr.; A. Schmitt, Pur. Agt.; G. M. Neylon, Pers. Dir.  
200 Ong St., El Monte, Calif.  
PERSONNEL: A. M. Wood, V. Pres. & Gen. Mgr.; F. Ohrmund, Plant Supt.; L. A. Dietzel, Pur. Supervisor; W. A. Foote, Sales Co-ordinator; L. Jennings, Pers. Dir.

**THE LOBDELL-EMERY MANUFACTURING CO., Alma, Mich.**

PERSONNEL: E. J. Lobdell, Jr., Pres. & Gen. Mgr.; O. K. Snyder, V. Pres. & Sales Mgr.; I. Scheitler, Secy.; O. A. Allen, Treas.; B. W. Lobdell, Pur. Agt.; E. W. Swett, Pers. Dir.

**THE LODGE & SHIPLEY MACHINE TOOL CO., 3055 Colerain Ave., Cincinnati, O.**

PERSONNEL: W. L. Doile, Pres. & Gen. Mgr.; F. Albrecht, V. Pres. & Treas.; L. L. Weber, Secy.; J. H. Myers, Sales Mgr.; G. Brakeman, Pur. Agt.; J. M. Manley, Pers. Dir.; F. A. Fritzsch, Chief Engr.

**LOGAN CO.,**

1115 Franklin Ave., Louisville, Ky.  
PERSONNEL: R. S. Logan, Pres. & Gen. Mgr.; E. C. Logan, V. Pres.; C. W. White, Secy.; W. H. Logan, Jr., Treas.; Z. Logan, Prod. Mgr.; A. B. Lang, Sales Mgr.

**LOGAN ENGINEERING CO.,**

Lawrence & Lamson Aves., Chicago, Ill.  
PERSONNEL: H. H. Logan, Pres.; R. E. Hines, V. Pres.; O. W. Lilliedahl, V. Pres. & Chief Engr.; O. E. Hesse, Secy. & Treas.; L. H. Fenwick, Sales Mgr.; L. H. Partridge, Pur. Agt.

**LOMBARD GOVERNOR CORP.,**

Main St., Ashland, Mass.  
PERSONNEL: H. E. Warren, Pres.; I. B. Dodge, Secy.; J. F. Power, Treas. & Gen. Mgr.; F. C. McNary, Prod. Mgr.; F. A. Hart, Sales Mgr.; H. L. Macewen, Pur. Dir.; C. Hodder, Pers. Dir.; R. F. Nichols, Adv. Mgr.; J. R. Campbell, Chief Engr.

**LONGINES WITTMANER WATCH CO.,**

580 Fifth Ave., New York, N. Y.  
PERSONNEL: J. V. P. Heinmuller, Pres.; F. Cartoun, V. Pres.; E. Detjen, Secy.; M. Guilden, Treas.

**LORD MANUFACTURING CO., Erie, Pa.**

PERSONNEL: H. C. Lord, Pres.; T. Lord, V. Pres. & Gen. Mgr.; B. M. Hartman, Secy. & Treas.; W. B. Fisher, Works Mgr.; C. E. Beavan, Sales Mgr. & Adv. Mgr.; F. J. Kuhn, Pur. Dir.; D. R. Coddington, Pers. Dir.

**H. K. LORENTZEN, INC.,**

391 W. Broadway, New York 12, N. Y.  
PERSONNEL: H. K. Lorentzen, Pres.; S. R. Bond, V. Pres., Sales Mgr. & Adv. Mgr.; J. B. Hawkins, Gen. Mgr. & Chief Engr.; C. Jeckel, Prod. Mgr. & Pers. Dir.; J. R. Bond, Pur. Dir.

**LORENZEN INDUSTRIES,**

Municipal Airport, Niles, Mich.  
PERSONNEL: R. E. Lorenzen, Pres. & Chief Engr.

**LOS ANGELES STAMP & STATIONERY CO., 1500 S. Los Angeles St., Los Angeles, Calif.**

PERSONNEL: A. C. Davidson, Pres.; F. Heylek, V. Pres.; G. E. Rinehart, Secy. & Treas.; W. Knapp, Gen. Mgr.; F. Heylek, Jr., Pur. Agt.; H. R. Wade, Chief Engr.

**THE LOWE BROTHERS CO.,**

424 E. Third St., Dayton F2, O.  
PERSONNEL: D. A. Kohn, Pres.; C. W. Parrott, V. Pres. & Secy.; P. H. Harn, Treas.; L. L. Anderson, E. A. Daniels, Sales Mgrs.; W. T. Loges, M. Wright, Pur. Dir.; G. Clark, Pers. Dir.; P. B. Willis, Adv. Mgr.; J. Kohn, Chief Engr.

**THE LUFKIN RULE CO.,**

Saginaw, Mich.  
PERSONNEL: R. J. Thompson, Pres. & Gen. Mgr.; E. Russell, V. Pres.; H. F. Krauss, Secy. & Treas.; G. W. Keating, Prod. Mgr.; G. C. McBeth, Sales Mgr.; W. J. Zoellner, Pur. Dir.; R. Andrus, Pers. Dir.; N. A. Ellis, Adv. Mgr.; E. J. Witchger, Chief Engr.

# DOWMETAL

## MAGNESIUM ALLOYS

When you buy Dowmetal magnesium ingots, castings or wrought products, you are getting the unrivalled advantage of 27 years' experience in the production and fabrication of magnesium. Every step in the production process from the raw material to the finished part is under strict metallurgical control.

INGOTS  
STICKS  
ALLOY INGOTS  
MELTING FLUXES  
PROTECTIVE AGENTS  
WELDING FLUX

WELDING ROD  
SAND CASTINGS  
PERMANENT MOLD  
CASTINGS  
DIE CASTINGS  
BAR, ROD AND TUBING

EXTRUSIONS  
SHEET, STRIP AND PLATE  
FORGING STOCK  
FORGINGS  
FABRICATION  
FACILITIES

### MAGNESIUM DIVISION

**THE DOW CHEMICAL COMPANY, MIDLAND, MICHIGAN**

New York . Boston . Philadelphia . Washington . Cleveland . Detroit . Chicago  
St. Louis . Houston . San Francisco . Los Angeles . Seattle

Locked Cap Assembly  
Mechanically Depolarized  
Anti-Contraction, Expansion  
**LITTELFUSES**



Littelfuse makes Fuses for every instrument — Aircraft, Army, Navy, oversea, undersea, ordnance equipment, radio, etc. Silver-Plated Beryllium Copper Fuse Clips, Extractor Posts, Signaletts non-shatterable light indicators, etc. Write:

**LITTELFUSE INC.**

967 Ong St., El Monte, Calif.  
4797 Ravenswood Ave., Chicago 40, Ill.

**LINK-BELT**  
AIRCRAFT  
TACHOMETER  
TEST DRIVE



● It is the latest in the Link-Belt series of precision test rigs developed to give the aircraft industry the benefit of infinitely variable speed control in testing all types of aircraft instruments and auxiliaries. Send for copies of Books 1974 and 1874.

**LINK-BELT COMPANY**  
2045 W. Hunting Park Ave.,  
Philadelphia 40, Pa. 9308-B

**LYON METAL PRODUCTS, INC.,**

242 Madison Ave., Aurora, Ill.  
 PERSONNEL: E. D. Power, Pres. & Gen. Mgr.; H. B. Spackman, V. Pres. & Sales Mgr.; E. W. Nix, Secy. & Treas.; J. T. Hillenbrand, Pur. Agt.; M. A. Judd, Pers. Dir.; L. B. Rhodes, Pub. Dir.; J. B. O'Connor, Chief Engr.

**LYON-RAYMOND CORP., Greene, N. Y.**

PERSONNEL: G. G. Raymond, Pres. & Treas.; C. M. Raymond, V. Pres.; N. G. Harrison, Secy.

## M

**WARREN McARTHUR CORP.,**

One Park Ave., New York 16, N. Y.  
 PERSONNEL: W. McArthur, Pres. & Gen. Mgr.; C. McArthur, V. Pres.; O. Crouse, Secy.; G. A. Kent, Treas.; L. W. Adler, Prod. Mgr.; K. C. Crouse, Sales Mgr.; D. B. Robinson, Pur. Dir.; E. M. Brill, Pers. Dir.; E. S. Jordon, Pub. Dir. & Adv. Mgr.; S. J. Lloyd, Chief Engr.

**McCAULEY STEEL PROPELLER CO.,**

Dayton, O.

**McCORD RADIATOR & MFG. CO.,**

2587 E. Grand Blvd., Detroit, Mich.  
 PERSONNEL: A. C. McCord, Pres.; C. O. Chesnut, V. Pres.; L. M. Hamlin, Secy.; W. G. Hancock, Sales Mgr.; D. A. Pyke, Pur. Agt.; J. A. Harley, Pers. Dir.; E. O. Bodkin, Pub. Dir.; H. E. Schank, Chief Engr.

**McGILL MFG. CO., INC., BEARING DIV.,**

Valparaiso, Ind.  
 PERSONNEL: C. S. McGill, Pres., Treas. & Gen. Mgr.; R. McGill, V. Pres.; W. E. Brownell, Secy. & Sales Mgr.; J. J. O'Connor, Pur. Agt.; O. V. Cederberg, Chief Engr.

**McGRATH ST. PAUL CO.,**

50 E. Fifth St., St. Paul, Minn.  
 PERSONNEL: J. B. McGrath, Pres.; E. J. McGrath, V. Pres.; H. R. Gilden, Gen. Mgr.; A. J. Schaake, Prod. Mgr.

**THE McKAY CO., York, Pa.**

PERSONNEL: T. J. McKay, Pres. & Treas.; J. C. McKay, V. Pres.; F. A. Bond, V. Pres., Secy. & Sales Mgr.

**IRWIN McNICIE,**

5314 Mt. Royal Dr., Los Angeles, Calif.  
 PERSONNEL: I. McNiece, Owner & Gen. Mgr.; N. E. Jones, Associate.

**McQUAY, INC., 1600-1729 Broadway St.,**

N. E., Minneapolis, Minn.  
 PERSONNEL: R. J. Resch, Pres.; G. Kelting, V. Pres.; E. H. Seelert, Secy., Treas. & Gen. Mgr.; D. P. Wilson, Prod. Mgr.; R. C. Colman, Sales Mgr.; E. M. Fox, Pur. Dir., Pub. Dir. & Adv. Mgr.; C. Pinney, Pers. Dir.; C. Rink, Chief Engr.

**McQUAY-NORRIS MANUFACTURING CO.,**

2320 Marconi Ave., St. Louis 10, Mo.  
 PERSONNEL: W. K. Norris, Pres.; A. G. Drefs, A. J. Mummert, V. Pres.; C. C. Auten, Secy.; C. R. Wippert, Sales Mgr.; C. C. Tapscott, Adv. Mgr.

**THE MB MANUFACTURING CO., INC.,**

1060 State St., New Haven, Conn.  
 PERSONNEL: R. W. Mettler, Pres.; C. W. Blanchard, V. Pres.; A. W. Chambers, Secy.; G. H. Mettler, Treas.; J. D. Smith, Gen. Mgr.; F. W. Hunter, Prod. Mgr.; C. C. Mettler, Sales Mgr.; L. K. Allen, Pur. Dir.; J. M. Wirtz, Pers. Dir.; T. MacDonald, Adv. Mgr.; J. Schmitt, Chief Engr.

**MACWHYTE CO.,**

2901 14th Ave., Kenosha, Wis.  
 PERSONNEL: J. S. Whyte, Pres. & Gen. Mgr.; R. B. Whyte, V. Pres.-Operations; H. E. Sawyer, V. Pres. & Treas.; H. Gay, Secy.; R. G. Diehl, Sales Mgr., Aircraft; C. F. Lamich, Pur. Agt.; E. G. Knoedler, Pers. Dir.; F. J. Nelson, Pub. Dir.; H. G. Kinder, Chief Engr.

**MAGEE SHEET METAL MACHINERY CO.,**

Ypsilanti, Mich.  
 PERSONNEL: W. R. Magee, Prop.; D. G. Seymour, Supt.; R. Kiser, Pur. Agt.

**MAGNAFLUX CORP.,**

5908 Northwest Highway, Chicago, Ill.  
 PERSONNEL: A. V. de Forest, Pres.; F. B. Doane, V. Pres. & Treas.; T. C. Diller, Secy.; W. E. Thomas, Sales Mgr.; W. L. Burson, Jr., Pur. Agt.; H. T. Nordstrom, Chief Engr.

**MAGNUS CHEMICAL CO., INC.,**

South Ave., Garwood, N. J.  
 PERSONNEL: W. M. Campbell, Pres.; R. W. Mitchell, V. Pres.; W. M. Garbe, Secy.; O. Buss, Gen. Mgr.; D. Blanchard, Sales Mgr.; A. H. Johnson, Pur. Agt.; R. Kreie, Pub. Dir.; M. Zinty, Chief Engr.

**MAJOR AIRCRAFT FOUNDRY,**

Puente, Calif.  
 PERSONNEL: L. Crosby, Pres., Pub. Dir. & Adv. Mgr.; A. J. Leonard, V. Pres., Gen. Mgr., Prod. Mgr. & Sales Mgr.; V. Hicks, Secy.; H. Leonard, Treas.; H. Bryan, Pur. Dir. & Pers. Dir.; C. Woods, Chief Engr.

**MALABAR MACHINE CO.,**

5722 Santa Fe Ave., Los Angeles 11, Calif.  
 PERSONNEL: E. P. Grime, W. F. Foy, Partners; G. H. Hutchins, Gen. Mgr. & Sales Mgr.; B. Mattheson, Pur. Dir.; E. Grady, Pers. Dir.; C. Crank, Pub. Dir. & Adv. Mgr.; E. P. Grime, Chief Engr.

**MALL TOOL CO.,**

7740 S. Chicago Ave., Chicago, Ill.  
 PERSONNEL: A. W. Mall, Pres.; W. H. Sanders, Secy. & Treas.; J. W. Innes, Pur. Dir.; M. Rehnquist, Adv. Mgr.

**P. R. MALLORY & CO., INC.,**

3029 E. Washington St., Indianapolis 6, Ind.  
 PERSONNEL: P. R. Mallory, Pres.; J. E. Cain, V. Pres. & Gen. Mgr.; L. Robbin, V. Pres. & Engr.; G. Fotheringham, Secy.; M. E. Hamilton, Treas.; H. W. Sams, Sales Mgr.; G. C. Mercer, Pur. Dir.; A. E. Sinclair, Pers. Dir.; W. T. Craigle, Adv. Mgr.

**MANBEE EQUIPMENT CO.,**

406 S. Kolmar Ave., Chicago, Ill.  
 PERSONNEL: S. W. Martin, Pres.; J. H. Pereue, V. Pres.; N. Evasink, Secy.; E. E. Martin, Treas.

# Modern Material-Handling Equipment



*especially developed  
for the*

## **AVIATION** **INDUSTRY**



Of interest to the Aviation Industry is the invaluable fund of experience accumulated by LYON-Raymond, in designing and manufacturing many different devices to expedite material handling by airplane manufacturers, motor plants, equipment makers, and military and commercial airfields—for application to manufacturing, servicing and operating tasks.

### **LYON-Raymond Hydraulic HOIST**

**The largest equipment ever built  
for installing and removing engines  
in planes at airfields.**

The facilities of LYON-Raymond are available for the design and production of material-handling units involving either the adaptation of our standard equipment, or the engineering development of new and strictly specialized units.

Write us regarding your requirements. Our recommendations will be submitted without obligation.

# **LYON-Raymond**

## **CORPORATION**

297 MADISON ST.



GREENE, N. Y.

LYON-Raymond Standard Products: Hydraulic Lift Trucks . . . Hydraulic Pallet Trucks . . . Hydraulic Elevating Trucks . . . Hydraulic Elevating Tables . . . Hydraulic Die Handling Trucks . . . Hydraulic Sheet Handling Trucks . . . Hydraulic Stacking, Tying, Hoisting Equipment . . . Hydraulic Pumps—hand or foot operated . . . Hydraulic Welding Positioners.

**MANLOVE & SPAULDING MFG. CO., 3524**  
Union Pacific Ave., Los Angeles, Calif.  
PERSONNEL: P. M. Manlove, Pres. & Pur. Agt.;  
L. B. Manlove, V. Pres. & Pers. Dir.; R. E.  
Spaulding, Secy., Gen. Mgr. & Sales Mgr.

**MANNING, MAXWELL & MOORE, INC.,**  
11 Elias St., Bridgeport, Conn.  
PERSONNEL: R. R. Wason, Pres.; C. H. Butter-  
field, V. Pres. & Sales Mgr.; F. M. Kreiner,  
Secy. & Treas.; H. Merrill, Gen. Works Mgr.;  
W. T. O'Connor, Pur. Agt.; W. I. Newman,  
Pers. Dir.; I. B. VanHouten, Pub. Dir.; E.  
H. Hammond, Chief Engr.

**MANUFACTURERS CHEMICAL CORP.,**  
Snyder Ave., Berkeley Heights, N. J.  
PERSONNEL: H. W. Harding, Pres., Treas. &  
Gen. Mgr.; K. M. Joehneck, V. Pres. & Prod.  
Mgr.; C. Burke, Secy.

**MANUFACTURERS SCREW PRODUCTS,**  
216-222 W. Hubbard St., Chicago 10,  
Ill.  
PERSONNEL: B. J. Sackheim, Pres.; H. F.  
Tiffen, Gen. Sales Mgr.; I. B. Greene, Pur.  
Agt.; J. S. Molan, Pers. Dir.; A. J. Cherry,  
Prod. Engr.

**MAPLEWOOD MACHINERY CO.,**  
2634 Fullerton Ave., Chicago, Ill.  
PERSONNEL: J. J. Ingels, Pres.; B. Ingels, V.  
Pres.; F. D. Sadler, Secy. & Sales Mgr.

**MARBURG BROTHERS, INC.,**  
90 West St., New York, N. Y.  
PERSONNEL: T. H. Marburg, Pres.; L. C.  
Marburg, Treas.

**MARINE-AIR RESEARCH CORP.,**  
215 Main St., Annapolis, Md.  
Essex, Conn.  
PERSONNEL: F. M. Weir, Pres.; P. M.  
Dolan, V. Pres. & Chief Engr.; R. E. Bell, V.  
Pres. & Treas.; W. J. McWilliams, Secy.

**MARLIN-ROCKWELL CORP.,**  
402 Chandler St., Jamestown, N. Y.  
PERSONNEL: A. C. Davis, Pres. & Gen. Mgr.;  
J. H. Walters, V. Pres. & Treas.; S. W. Brandel,  
Secy. & Works Mgr.; H. A. Johnston, Sales  
Mgr.; C. A. Berg, Pur. Dir.; C. W. Rauch, Adv.  
Mgr.; L. A. Cummings, Chief Engr.

**MARMAN PRODUCTS CO.,**  
940 W. Redondo Blvd., Inglewood, Calif.  
PERSONNEL: Z. Marx, Pres.; A. J. Miller, Secy.  
& Treas.; G. A. Cunningham, Gen. Mgr.; J. T.  
King, Chief Engr.

**THE MARQUETTE METAL PRODUCTS**  
**CO., 1145 Galewood Dr., Cleveland, O.**  
PERSONNEL: H. Gleitz, Pres.; J. S. Kustin,  
Secy. & Treas.; E. D. Jackson, Mgr., Aircraft  
Accessories Dept.; C. E. Miller, Sales Mgr.;  
W. O. Yohe, Pur. Agt.

**MARTIN-DECKER CORP.,**  
3431 Cherry Ave., Long Beach, Calif.  
PERSONNEL: W. R. Martin, Pres. & Gen. Mgr.;  
E. L. Decker, Secy., Treas. & Sales Mgr.; H.  
J. Blythe, Pur. Agt.

**THE MARTIN-SENOUR CO.,**  
2520 S. Quarry St., Chicago, Ill.  
PERSONNEL: Z. E. Martin, Pres.; W. M.  
Stuart, V. Pres. & Gen. Mgr.; H. T. Johnson,  
Aviation Sales Mgr.

**THE MARTINDALE ELECTRIC CORP.,**  
1375 Hird Ave., Lakewood, O.  
PERSONNEL: E. H. Martindale, Pres.; G. E.  
Martindale, V. Pres.; W. N. Osburn, Secy.; H.  
McFarland, Treas.; O. W. Scharping, Chief  
Engr

**MARVEL-SCHEBLER CARBURETOR DIV.,**  
**BORG-WARNER CORP., 1910 St.**  
John St., Flint, Mich.  
PERSONNEL: S. W. Gray, Pres.; J. R. Emerson,  
V. Pres. & Chief Engr.; W. E. Walpole, Secy.  
& Treas.; N. M. Hurry, Sales Mgr.; W. G.  
Ryan, Pur. Agt.

**MARYLAND METAL BUILDING CO., INC.,**  
Race & McComas Sts., Baltimore, Md.  
PERSONNEL: C. H. Michel, Pres., Gen. Mgr.,  
Sales Mgr. & Chief Engr.; O. F. Murphy,  
V. Pres.; I. J. Wilcoxon, Secy.; R. G. Bristow,  
Treas.; J. L. Perkins, Pur. Dir.

**MASSACHUSETTS MOHAIR PLUSH CO.,**  
3701 N. Broad St., Philadelphia 40, Pa.  
PERSONNEL: H. M. Bliss, Pres.; J. E. Duval,  
V. Pres., Gen. Mgr. & Sales Mgr.

**MASTER LOCK CO., Milwaukee, Wisc.**  
PERSONNEL: P. E. Yolles, Pres.; S. M. Soref,  
V. Pres.; S. Stahl, Secy. & Pur. Agt.; H. E.  
Soref, Treas.; E. J. Tower, Sales Mgr.; H.  
Peterson, Chief Engr.

**THE W. L. MAXSON CORP.,**  
460 W. 34th St., New York, N. Y.  
PERSONNEL: W. L. Maxson, Pres.

**MECHANICAL PRODUCTS, INC.,**  
618 N. Mechanic St., Jackson, Mich.  
PERSONNEL: A. D. Knapp, Pres., Gen. Mgr. &  
Sales Mgr.; C. W. Ryerson, V. Pres. & Prod.  
Mgr.; H. J. Kline, V. Pres. & Chief Engr.; H. C.  
Halsey, Secy. & Treas.; I. L. Gibbs, Pur. Dir.;  
W. B. Meade, Pers. Dir.

**MELLUS BROTHERS & CO.,**  
305 E. Fourth St., Los Angeles, Calif.  
PERSONNEL: L. R. Mellus, Pres. & Gen. Mgr.;  
F. H. Mellus, E. J. Mundy, V. Pres.; G. G.  
Mellus, Secy. & Treas.

**MENASCO MANUFACTURING CO.,**  
805 S. San Fernando Blvd., Burbank,  
Calif.  
PERSONNEL: J. E. Royall, Pres.; R. R. Miller,  
V. Pres. & Secy.; E. V. Carlson, Treas.; J. E.  
F'Anson, Works Mgr.; E. B. Challenor, Prod.  
Mgr.; J. H. Smith, Sales Mgr.; D. E. Erickson,  
Pur. Dir.; C. H. Allred, Pers. Dir.; W. G. Wood,  
Chief Engr.

**MENAUGH-DUTTERER CO.,**  
549 Washington Blvd., Chicago 6, Ill.  
PERSONNEL: J. E. Menaugh, Pres.; R. J. L.  
Dutterer, Chief Engr.

**MERCURY AIRCRAFT INC.,**  
Hammondsport, N. Y.  
PERSONNEL: J. F. Meade, Pres. & Gen. Mgr.;  
E. M. Meade, V. Pres.; M. C. Close, Secy.;  
S. Singer, Treas.; R. F. Moore, Dir. of Procure-  
ment; C. F. Guthy, Pur. Agt.; M. D. Linehan,  
Pers. Dir.; R. W. Heffer, Chief Engr.

**MERCURY CHEMICAL CO.,**  
2706 David Stott Bldg., Detroit, Mich.  
PERSONNEL: W. M. Keese, Gen. Mgr.

**THE MERCURY MANUFACTURING CO.,**  
4044 S. Halsted St., Chicago 9, Ill.  
PERSONNEL: A. G. Leonard, Pres.; L. J. Kline,  
V. Pres., Sales Mgr., Pub. Dir. & Adv. Mgr.;  
O. T. Henkle, Secy. & Treas.; O. T. Henkle, Jr.,  
Asst. Gen. Mgr.; P. K. McCullough, Prod.  
Mgr.; C. Brinkerhoff, Pur. Dir.; P. S. Allen,  
Pers. Dir.; H. Milz, Chief Engr.

**THE MERIAM CO.,**  
1955 W. 112th St., Cleveland, O.  
PERSONNEL: J. B. Meriam, Pres. & Gen. Mgr.;  
H. G. Schowe, V. Pres.; C. Meriam, Secy.;  
J. B. Meriam, Jr., Treas.; A. A. Hejduk, Sales  
Mgr.; L. C. Deunk, Pur. Agt.

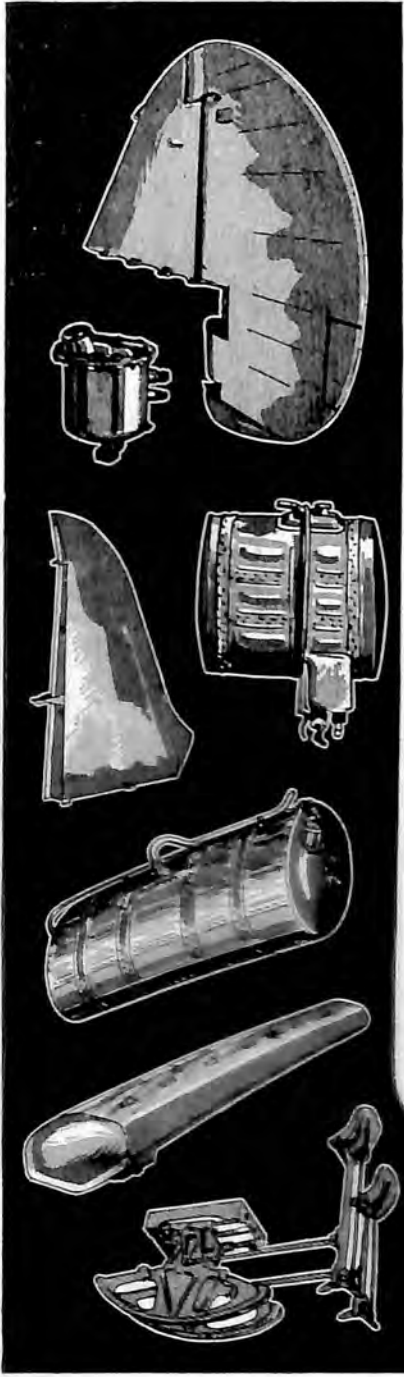

... for 24 years,  
 the Mercury Mark  
 has stood for pre-  
 cision and skill in  
 craftsmanship, plus  
 a sixth sense which  
 can be acquired only  
 through experience  
 ... the *know how* to  
 do a job right ...

aluminum fuel and oil  
 tanks • ailerons, fins,  
 rudders and similar  
 surfaces • aircraft parts  
 and accessories.

AT *The Cradle of Aviation*





**MERRILL ENGINEERING LABORATORIES, 1230 Lincoln St., Denver, Colo.**

PERSONNEL: M. S. Merrill, Pres. & Chief Engr.; J. W. Williams, Gen. Mgr. & Pur. Agt.; R. L. West, Sales Mgr.

**MET-L-WOOD CORP.,**

6755 W. 65th St., Chicago, Ill.

PERSONNEL: C. C. Kendrick, Pres.; L. M. Crow, Jr., V. Pres., Treas., Gen. Mgr. & Pur. Agt.; I. J. Novotny, Secy. & Chief Engr.; G. K. Lewis, Sales Mgr.; L. L. Lord, Pers. Dir.

**METAL & THERMIT CORP.,**

120 Broadway, New York, N. Y.

PERSONNEL: F. H. Hirschland, Pres.; E. Becher, W. S. Smith, V. Pres.; J. B. Tinnon, V. Pres. & Sales Mgr.; H. E. Rogers, Secy.; B. Anderson, Treas.; E. A. Leaverty, Pur. Agt.; M. L. Smith, Pub. Dir.; J. H. Deppeler, Chief Engr.

**METAL AND TOOL RECONDITIONING SERVICE, 250 W. 54th St., New York 17, N. Y.**

PERSONNEL: S. M. Cleja, Pres. & Treas.; H. Esquerre, V. Pres.; M. Adams, Secy.; V. G. Herman, Gen. Mgr. & Pur. Dir.; M. Becht, Prod. Mgr.; A. E. Benfield, Sales Mgr.

**METAL CARBIDES CORP.,**

107 E. Indianola Ave., Youngstown, O.

PERSONNEL: R. T. Beeghly, V. Pres.; W. E. Schetz, Secy. & Treas.; H. L. Sprinkel, Pur. Dir.; J. A. Ritz, Chief Engr.

**METALIZING ENGINEERING CO., INC.,**

21-07 41st Ave., Long Island City, N. Y.

PERSONNEL: R. A. Axline, Pres.; W. C. Reid, V. Pres., Sales Mgr. & Pub. Dir.; G. S. Lufkin, Secy. & Treas.; R. Dwyer, Pur. Agt.; H. Ingham, Chief Engr.

**METALS & CONTROLS CORP., GENERAL PLATE DIV., 34 Forest St., Attleboro, Mass.**

PERSONNEL: R. Willard, Pres.; C. J. Stone, Treas.; V. Davignon, Gen. Mgr.; J. A. Payette, Sales Mgr.; E. Carpenter, Pur. Agt.

**METZGAR CO., 115 Logan St., S. W., Grand Rapids, Mich.**

PERSONNEL: L. Metzgar, R. H. Metzgar, Partners.

**E. B. MEYROWITZ, INC.,**

520 Fifth Ave., New York, N. Y.

PERSONNEL: E. Meyrowitz, Pres.; W. N. Cook, V. Pres. & Gen. Mgr.; J. S. Schultz, Secy. & Treas.

**MICA INSULATOR CO.,**

200 Varick St., New York, N. Y.

PERSONNEL: M. A. Chapman, Pres.; J. M. Coffey, V. Pres.; E. Nelson, Secy. & Treas.; C. P. Mills, Sales Mgr.; Q. F. Jardine, Pur. Agt.; R. H. Spry, Chief Engr.

**MICHIGAN TOOL CO.,**

7171 E. McNichols Rd., Detroit, Mich.

PERSONNEL: O. L. Bard, Pres. & Treas.; M. R. Anderson, V. Pres.; J. C. Drader, Gen. Mgr.; P. Norman, Pur. Agt.; C. R. Staub, Chief Engr.

**MICHIGAN WIRE CLOTH CO.,**

2100 Howard St., Detroit 16, Mich.

PERSONNEL: A. A. Bull, Pres.; H. A. Wilson, V. Pres., Secy. & Gen. Mgr.; S. W. Farnsworth, Treas.; J. C. Lee, Prod. Mgr.; W. H. Blodgett, Sales Mgr. & Adv. Mgr.; G. H. Leckey, Pur. Dir.; J. G. Garbacik, Pers. Dir.; C. G. Haslam, Chief Engr.

**MICRO SWITCH CORP., Freeport, Ill.**

PERSONNEL: W. B. Schulte, Pres., Pub. Dir. & Adv. Mgr.; A. L. Riche, V. Pres. & Gen. Mgr.; A. A. Laporte, Secy.; M. W. Eaton, Treas. & Pers. Dir.; W. W. Gilmore, Prod. Mgr.; F. E. Wilsey, Sales Mgr.; W. J. Young, Pur. Dir.; P. H. Celander, Chief Engr.

**MICROMATIC HONE CORP.,**

8100 Schoolcraft, Detroit 4, Mich.

PERSONNEL: K. W. Connor, Pres.; H. M. Whittaker, V. Pres.; A. J. Prentice, Secy. & Treas.; F. W. Thomas, Factory Mgr.; D. S. Connor, Sales Mgr.; R. W. Gauss, Pur. Dir.; L. S. Martz, Pub. Dir.; W. H. Harris, Jr., Chief Engr.

**MID-STATE MFG. CO.,**

21 E. Jefferson St., Waupun, Wisc.

PERSONNEL: C. O. Thomas, Pres. & Treas.; A. W. Fairchild, V. Pres. & Secy.; A. G. Gibbons, Gen. Mgr.; B. H. Bredeson, Pur. Agt.; H. C. Engelbracht, Pers. Dir.; H. H. Hanson, Chief Engr.

**THE ALEXANDER MILBURN CO.,**

1424 W. Baltimore St., Baltimore, Md.

PERSONNEL: A. F. Jenkins, Pres. & Treas.; W. L. Lawrence, V. Pres. & Gen. Mgr.; M. D. Maguire, Secy.; E. R. Kanely, Pur. Agt.; J. F. Williams, Pub. Dir.

**THE MILFORD RIVET & MACHINE CO., Milford, Conn.**

PERSONNEL: F. H. Merwin, Pres. & Gen. Mgr.; S. Simpson, V. Pres.; R. B. Davis, Secy.; A. R. Knight, Treas.; A. M. Birks, Sales Mgr.; H. P. Brewer, Pur. Agt.; V. M. Caltham, Chief Engr.

**JAMES MILLEN MFG. CO., INC.,**

150 Exchange St., Malden, Mass.

PERSONNEL: J. Millen, Pres., Treas. & Gen. Mgr.; R. S. Millen, V. Pres.; C. Barrett, Secy.; F. Bearse, Pur. Agt.; R. W. Caywood, Chief Engr.

**MILLER & CROWNSHIELD,**

Greenfield, Mass.

PERSONNEL: F. K. Crowningshield, Gen. Mgr.

**MILLERS FALLS CO., Greenfield, Mass.**

PERSONNEL: P. Rogers, Pres.; G. U. Hatch, V. Pres. & Sales Mgr.; E. D. Holtby, Secy. & Treas.; C. W. Parsons, Pur. Dir.; K. Y. Taylor, Adv. Mgr.; W. J. Parsons, Chief Engr.

**W. K. MILLHOLLAND MACHINERY CO.,**

1048 Fairfield Ave., Indianapolis, Ind.

PERSONNEL: W. K. Millholland, Pres. & Gen. Mgr.; I. M. Millholland, Secy., Treas., & Pur. Agt.; D. Millholland, Sales Mgr.

**MILWAUKEE VALVE CO.,**

2375 S. Burrell St., Milwaukee, Wisc.

PERSONNEL: V. Fina, Pres.; P. Fina, Secy.; C. S. Bigelow, Sales Mgr.; A. A. Stollenwerk, Pur. Agt.; W. Hoelzer, Chief Engr.

**MINE SAFETY APPLIANCES CO.,**

Braddock, Thomas & Meade Sts., Pittsburgh 8, Pa.

PERSONNEL: G. H. Deike, Pres.; J. F. Beggy, V. Pres.; J. T. Ryan, Jr., Gen. Mgr.; J. B. Davies, Sales Mgr.; A. Maher, Pur. Dir.; N. R. Chillingworth, Adv. Mgr.

**MINIATURE PRECISION BEARINGS,**

Keene, N. H.

PERSONNEL: H. D. Gilbert, Treas.; A. N. Daniels, Res. Mgr.; W. S. Pierce, Jr., Chief Engr.

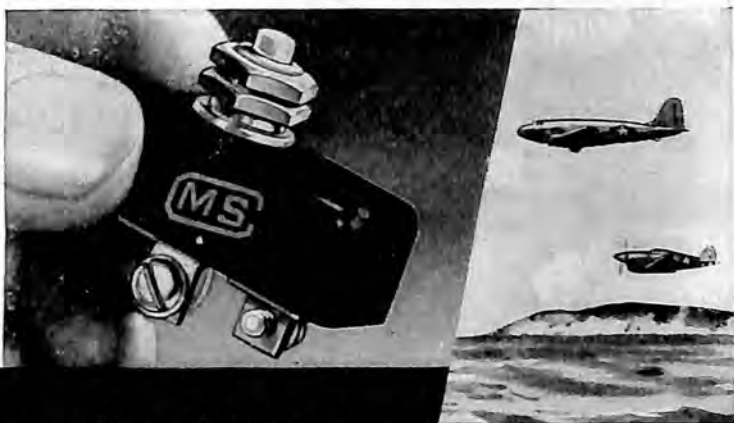

a smaller, lighter  
**Micro Switch**

**... that is meeting high favor with Aircraft Engineers**

Designed for post-war use, the Peanut Micro Switch so filled the bill for a number of military aircraft requirements that we are now making them in large scale production.

This diminutive switch is smaller than the basic Micro Switch, is very robust, highly resistant to vibration, lighter in weight, lower in cost.

The Peanut Micro Switch is so designed that it can be used without any enclosing case, allowing the actuating movement to be applied anywhere over a large portion of the upper spring. Used with a Bakelite case, a convenient stem mounting is provided. The construction allows inherent overtravel beyond the point of operation sufficient for most uses.

The Peanut Micro Switch, encased in Bakelite housing, weighs .048 lb. This switch resists vibration and acceleration up to 300 times gravity. Operating force is 33 ounces maximum and the movement differential is 0.040" maximum.

Contact separation up to .085" can be varied in manufacture to meet requirements. This wide gap is particularly valuable on DC loads. To provide the high unit contact pressure for low voltage applications, contacts of 99.95% pure silver are formed with a knurled surface.

Send for Catalog No. 70 for general data on Micro Switch for aircraft. Ask for as many copies as you need.



*Micro Switch Corporation, Freeport, Illinois*

Branches: 43 E. Ohio St., Chicago (11) • 11 Park Place, New York City (7)  
4900 Euclid Ave., Cleveland (3) • 1709 W. 8th St., Los Angeles (14)  
Sales and Engineering Offices: Boston • Hartford

The trademark MICRO SWITCH is our property and identifies switches made by Micro Switch Corp. © 194 :

**MICRO  SWITCH**

*Made Only By Micro Switch Corporation...Freeport, Illinois, U. S. A.*

**MISENER MFG. CO., INC.,**  
326 E. Washington St., Syracuse, N. Y.  
PERSONNEL: M. L. Misener, Pres. & Gen. Mgr.; J. A. Misener, Secy. & Pur. Agt.; I. Ballard, Treas.; G. B. Armatage, Sales Mgr.

**MOBILE REFRIGERATION DIVISION,**  
**BOWSER, INC.,** 38-32 54th St., Woodside, N. Y.

PERSONNEL: D. Pyzel, IV, Pres. & Gen. Mgr.; P. W. Hunter, V. Pres.; M. Siecke, Prod. Mgr.; E. S. Ronk, Pur. Dir.; D. Conway, Pers. Dir.; E. Ludwig, Chief Engr.

**MODELS, INC.,**  
1112-12th St., N. Bergen, N. J.  
PERSONNEL: L. F. Werner, Pres. & Gen. Mgr.; S. A. Odium, V. Pres.; C. E. Meyle, Secy. & Pers. Dir.; E. H. Erickson, Treas.

**MODERN ENGINEERING CO., INC.,**  
3401-15 Pine Blvd., St. Louis, Mo.  
PERSONNEL: A. J. Fausek, Pres. & Gen. Mgr.; I. F. Fausek, V. Pres. & Treas.; J. J. Keane, Secy., Sales Mgr. & Adv. Mgr.; W. L. Reedy, Prod. Mgr.; N. A. Schmidt, Chief Engr.

**MOLDED INSULATION CO.,**  
335 E. Price St., Philadelphia, Pa.  
PERSONNEL: V. I. Zelov, Pres. & Treas.; A. Heer, V. Pres.; W. T. Bradbury, Gen. Mgr.; E. A. Berger, Sales Mgr. & Pers. Dir.; R. M. Connor, G. E. Schoen, Pur. Agts.; A. Zillger, A. Aichinger, Chief Engrs.

**MONARCH ALLOYS CO.,** Ravenna, O.  
PERSONNEL: E. P. Carter, Gen. Mgr.

**MONARCH ALUMINUM MFG. CO.,**  
9301 Detroit Ave., Cleveland, O.  
PERSONNEL: R. Deutsch, Pres. & Treas.; H. J. Deutsch, V. Pres.; D. R. Gould, Secy.; H. Davis, Sales Mgr.; O. Ulrich, Pur. Agt.; C. Carver, Chief Engr.

**THE MONARCH MACHINE TOOL CO.,**  
Sidney, O.  
PERSONNEL: W. E. Whipp, Pres., Treas. & Gen. Mgr.; P. A. Abe, V. Pres.; F. C. Dull, V. Pres. & Secy.; J. A. Raterman, V. Pres. & Pur. Agt.; H. A. Toy, Sales Mgr.; C. A. Bickel, Chief Engr.

**MONARCH METAL WEATHERSTRIP CORP.,** 6333 Etzel Ave., St. Louis, Mo.  
PERSONNEL: J. A. Goellner, Pres.; A. N. Lane, V. Pres. & Sales Mgr.; H. C. Albrecht, Secy. & Treas.; F. J. Kick, Chief Engr.

**MONITE WATERPROOF GLUE CO.,**  
1628 N. Second St., Minneapolis 11, Minn.  
PERSONNEL: H. L. Prestholdt, Pres.; H. W. Mattison, V. Pres.; M. A. Robinson, Secy.

**MONMOUTH PRODUCTS CO.,**  
1929-41 E. 61st St., Cleveland, O.  
PERSONNEL: E. L. Davis, Pres. & Gen. Mgr.; G. M. Saizman, V. Pres.; G. L. Jameson, Secy.; H. D. Hubbs, Treas. & Sales Mgr.; S. Waite, Pur. Agt.; G. L. Ferguson, Chief Engr.

**MONO SERVICE CO.,**  
349 Oraton St., Newark 4, N. J.  
PERSONNEL: E. Z. Taylor, Pres.; C. L. Marshall, V. Pres. & Gen. Mgr.; J. C. Myers, V. Pres.; E. F. Wright, Secy., Treas., & Adv. Mgr.; H. Wooton, Prod. Mgr.; R. L. Shearer, Sales Mgr.; G. Van Buskirk, Pur. Dir.

**MONOGRAM MANUFACTURING CO.,**  
3412 Washington St., Los Angeles, Calif.  
PERSONNEL: H. H. Helbush, Pres.; E. R. Livingston, V. Pres.; L. T. Hutter, Secy.

**MONSANTO CHEMICAL CO.,** St. Louis, Mo.  
PERSONNEL: E. M. Queney, Pres.; C. Belknap, V. Pres.; W. W. Schneider, Secy.; F. A. Ulmer, Treas.

Plastics Div.  
Springfield, Mass.  
PERSONNEL: J. C. Brooks, Gen. Mgr.; J. H. Clark, Sales Mgr.; G. M. Bullard, Pur. Agt.; S. H. Colton, Pers. Dir.; J. R. Turnbull, Pub. Dir.

Merrimac Div.  
Everett Station, Boston, Mass.  
PERSONNEL: E. M. Queney, Pres.; W. M. Rand, V. Pres. & Gen. Mgr.; W. W. Schneider, Secy.; F. A. Ulmer, Treas.; L. A. Pratt, Sales Mgr.; E. E. Brainard, Pur. Agt.; C. E. Serrens, Pers. Dir.; P. A. Singleton, Pub. Dir.; J. B. Flaws, Chief Engr.

**MOORE DROP FORGING CO.,**  
Springfield, Mass.  
PERSONNEL: J. M. Collins, Pres. & Treas.; H. G. Dickey, A. T. Murray, V. Pres.; E. Abbe, V. Pres. & Chief Engr.; F. Hatch, Secy.; N. B. Ellison, Sales Mgr.; A. Converse, Pur. Agt.

**MOORE-EASTWOOD & CO.,**  
537 Monument Ave., Dayton, O.  
PERSONNEL: H. C. Moore, Gen. Mgr.; L. N. Moore, Secy. & Treas.; L. Scheid, Pur. Agt.; R. C. Moore, Chief Engr.

**MORSE TOOL CO.,**  
116 E. Goldengate Ave., Detroit 3, Mich.  
PERSONNEL: W. S. Morse, Pres.; M. J. Morse, Secy.; W. H. Morse, Treas.; E. M. Graham, Gen. Mgr.; N. W. Crisp, Prod. Mgr.; R. J. Corkery, Sales Mgr.; F. L. Bearss, Pur. Dir.

**MOTOR MASTER PRODUCTS CORP.,**  
**AERONAUTICAL DIV.,** 549 Washington Blvd., Chicago, Ill.  
PERSONNEL: J. E. Menaugh, Gen. Mgr.; R. J. L. Dutterer, Chief Engr.

**MOTOR REBUILDING SPECIALTIES,**  
2634 S. Michigan Ave., Chicago, Ill.  
PERSONNEL: N. F. Clayborne, Owner, Gen. Mgr., & Sales Mgr.; R. S. Wieneck, Pur. Agt.; I. L. Clayborne, Pers. Dir.; L. E. Plassmeyer, Chief Engr.

**MU-SWITCH CORP.,**  
38 Pequit St., Canton, Mass.  
PERSONNEL: C. D. Pease, Pres.; H. R. Guild, Secy.; G. M. Crosby, Treas.; P. A. Lund, Asst. Gen. Mgr.; J. D. Blumenthal, Prod. Mgr.; K. R. Reed, Pur. Dir.; J. D. Bukay, Adv. Mgr.; M. E. Porter, Chief Engr.

**MURPHY VARNISH CO.,**  
224 McWhorter St., Newark, N. J.  
PERSONNEL: C. L. Roh, Pres.; P. S. Kennedy, V. Pres.; Z. Belcher, Secy.; F. Praegner, Treas.; H. W. Lay, Gen. Sales Mgr.; T. I. Savage, Pur. Agt.; R. H. Sommer, Pub. Dir.; A. Anderson, Chief Engr.

**THE MURRAY CORP. OF AMERICA,**  
7700 Russell St., Detroit 11, Mich.  
PERSONNEL: C. W. Avery, Pres.; B. C. Gould, V. Pres.-Operations; C. D. Widman, V. Pres.-Finance; J. Barrett, Secy. & Treas.; A. A. Derse, Prod. Mgr.; C. H. Menge, Sales Mgr. & Adv. Mgr.; M. B. Lindquist, Pur. Dir.; F. Hall, Pers. Dir.; J. P. Sexton, Pub. Dir.; O. Graebner, Chief Engr.

**MUSKEGON PISTON RING CO.,**  
Muskegon, Mich.  
PERSONNEL: T. E. McFall, Pres., H. G. Vaughan, V. Pres., G. A. Fiffield, Secy., G. W. Lundeen, Treas.



# ★ 3H CLAMPS = $\frac{\text{Precision}}{\text{Safety}}$

Among the many standardized precision clamps made by Monogram are the three types illustrated. Five different drill hole sizes are available. These three types are: *Open Spring, Plunger Seal* and *Triple Lock*. Locking needles for these clamps are swaged from cold drawn high carbon content tempered steel wire which gives high safety factor and ease in operation.

Standard Plunger Seal and standard Triple Lock clamps are completely sealed and cannot come apart. The small type clamp shown here is now being introduced to the market. Additional information regarding Monogram clamps is available upon request.

The new Monogram adjustable Applying Tool is an all-purpose applicator that will operate all known makes and sizes of clamps now on the market. All Monogram 3H Safety Clamps illustrated here are guaranteed for one year.



STANDARD PLUNGER SEAL  
(Small Type)



STANDARD TRIPLE LOCK  
(Small Type)



STANDARD OPEN SPRING



STANDARD PLUNGER SEAL  
(Large Type)



STANDARD TRIPLE LOCK  
(Large Type)

# MONOGRAM

**Manufacturing Company**  
3406 West Washington Boulevard  
Los Angeles 16, California

## N

**NASH ENGINEERING CO.,**  
44 Aryebo St., S. Norwalk, Conn.

**NASH-KELVINATOR CORP.,**  
14250 Plymouth Rd., Detroit 32, Mich.  
PERSONNEL: G. W. Mason, Pres.; H. G. Perkins, V. Pres.; H. J. Mellum, Secy.; G. V. Egan, Treas.; C. T. Lawson, Sales Mgr., Kelvinator Div.; L. F. Skutt, Sales Mgr.; Nash Div.; B. P. Watkins, Pur. Dir.; H. G. Little, Dir. Pub. Rel.; C. J. Coward, Adv. Mgr., Kelvinator Div.; N. Nyland, Adv. Mgr., Nash Div.; F. F. Kishline, Chief Engr.

**NATIONAL AIRCRAFT EQUIPMENT CO.,**  
275 North Ave. 19, Los Angeles, Calif.  
PERSONNEL: R. T. Kinney, Pres.; W. H. Kinney, L. L. Martin, V. Pres.; J. H. Byrnes, Treas.; R. P. Lewis, Plant Mgr.; D. Reynolds, Sales Mgr.; W. W. Grace, Pur. Agt.; H. H. Cox, Pers. Dir.; F. P. Bucklein, Chief Engr.

**NATIONAL AIRCRAFT MATERIALS CORP.,**  
P. O. Box 469, Rutland, Vt.  
PERSONNEL: P. R. Eaton, Pres. & Gen. Mgr., Sales Mgr. & Pur. Agt.; L. E. Eaton, Secy.; M. J. Eaton, Treas. & Pub. Dir.; M. V. Quigley, Pers. Dir.; C. Smith, Chief Engr.

**THE NATIONAL ALUMINUM CYLINDER HEAD CO.,** 3420 E. 93rd St., Cleveland, O.  
PERSONNEL: J. L. Schmeller, Pres.; F. G. Diffin, V. Pres. & Sales Mgr.; G. N. Wright, V. Pres. & Pur. Agt.; H. T. Schmeller, Secy.; L. G. Smith, Treas.

**NATIONAL AUTOMATIC TOOL CO., INC.,**  
Richmond, Ind.  
PERSONNEL: H. W. Bockhoff, Pres.; H. G. Beggs, V. Pres.; A. B. McCrea, Secy.; R. C. Schuerman, Treas.; S. S. Okel, Prod. Mgr.; E. D. Frank, Sales Mgr.; P. G. Nolte, Pur. Dir.; W. C. Harding, Pers. Dir.; F. J. Peters, Chief Engr.

**NATIONAL BROACH & MACHINE CO.,**  
5600 St. Jean Ave., Detroit, Mich.  
PERSONNEL: R. S. Drummond, Pres.; W. S. Praeg, V. Pres.; M. H. Crawford, Secy.; J. I. Schultz, Treas. & Pub. Dir.; F. Kirsten, Pur. Agt.; T. S. Gates, B. F. Bregi, Chief Engrs.

**THE NATIONAL BRONZE & ALUMINUM FOUNDRY CO.,** 529 Union Commerce Bldg., Cleveland, O.  
PERSONNEL: J. L. Schmeller, Pres. & Sales Mgr.; W. A. Muth, V. Pres. & Secy.; G. N. Wright, V. Pres. & Pur. Agt.; L. G. Smith, Treas.; E. Davis, Pers. Dir.; W. Butcher, Pub. Dir.

**THE NATIONAL COPPER & SMELTING CO.,** 1862 E. 123rd St., Cleveland, O.  
PERSONNEL: H. B. Smith, Pres.; C. L. Smith, Treas.

**NATIONAL MACHINE PRODUCTS,**  
150 W. Slauson Ave., Los Angeles, Calif.  
PERSONNEL: R. F. Sopris, Pres. & Gen. Mgr.; H. E. Vorhis, Secy. & Treas.; R. F. Schringer, Prod. Control Mgr.; A. L. Wilson, Sales Mgr., Pub. Dir. & Adv. Mgr.; W. E. Griffin, Pur. Dir.; G. P. Bristow, Pers. Dir.; J. Lampl, Chief Engr.

**THE NATIONAL MACHINERY CO.,**  
Tiffin, O.

**THE NATIONAL SCREW & MFG. CO.,**  
2440 E. 75th St., Cleveland, O.  
PERSONNEL: H. P. Ladds, Pres.; C. F. Newpher, V. Pres. & Sales Mgr.; B. H. Jones, Asst. V. Pres.; E. E. Griese, Secy. & Treas.; D. D. Greenshields, Prod. Mgr.; R. C. Burnham, Pur. Dir.; G. Kloppman, Pers. Dir.; H. C. Erdman, Chief Engr.

**NATIONAL TUBE CO.,**  
Frick Bldg., Pittsburgh 30, Pa.

**NATIONAL TWIST DRILL & TOOL CO.,**  
6522 Brush St., Detroit, Mich.  
PERSONNEL: H. L. McGregor, Pres.; E. J. Chamberlain, V. Pres. & Sales Mgr.; A. B. Hulsapple, Secy.; A. H. Mueckler, Treas.; H. A. McGregor, Gen. Mgr.; R. B. Kane, Pur. Agt.; C. J. Oxford, Pub. Dir. & Chief Engr.

**NATIONAL VENEER & LUMBER CO.,**  
Seymour, Ind.  
PERSONNEL: B. F. Swain, Pres. & Gen. Mgr.; M. B. Swain, V. Pres.; L. J. Heyne, Secy.; E. F. Sherer, Prod. Mgr. & Sales Mgr.; L. C. Moore, Pers. Dir.

**THE NEDCO CO.,**  
87 Rumford Ave., Waltham, Mass.  
PERSONNEL: A. C. Burleigh, Pres., Treas. & Gen. Mgr.; C. S. Burleigh, Secy.

**NEU-BART STAMPING & MFG. CO.,**  
120 W. Slauson Ave., Los Angeles 3, Calif.  
PERSONNEL: A. H. Neubauer, Pres. & Gen. Mgr.; G. Bartholomew, V. Pres., Secy. & Treas.

**NEW BRUNSWICK DIE MOLDING DIV. OF UNIVERSAL PLASTICS CORP.,** 235 Jersey Ave., New Brunswick, N. J.  
PERSONNEL: G. W. Pollitz, Pres. & Treas.; P. Le B. Whitney, V. Pres. & Gen. Mgr.; B. Kaye, Secy.; W. Dubusker, Prod. Mgr.; E. Knutsen, Pur. Dir.; E. Csaszar, Chief Engr.

**NEW DEPARTURE DIV., GENERAL MOTORS CORP.,** Bristol, Conn.  
PERSONNEL: F. G. Hughes, Gen. Mgr.; E. E. Gill, Prod. Mgr.; L. G. Sigourney, Sales Mgr.; J. A. Ashwell, Pur. Dir.; C. B. Greene, Pers. Dir.; W. R. Crumb, Pub. Dir.; C. B. Beckwith, Adv. Mgr.; T. C. D. Crow, Chief Engr.

**NEW ENGLAND SCREW CO.,** Keene, N. H.  
PERSONNEL: G. J. Holt, Pres. & Treas.; C. G. Holt, V. Pres., Secy. & Treas.; G. B. Holt, Gen. Mgr. & Sales Mgr.; L. W. Hewitt, Pur. Agt.

**THE NEW HAVEN CLOCK CO.,**  
New Haven, Conn.  
PERSONNEL: R. H. Whitehead, Pres. & Gen. Mgr.; E. Stevens, V. Pres. & Sales Mgr.; A. Ham, Secy.; P. H. English, Treas.; J. Whitehead, Pur. Agt.; S. Truesch, Pers. Dir.; R. H. Chirgwin, Pub. Dir.; G. Gabriel, Chief Engr.

**NEW JERSEY FULGENT CO., INC.,**  
Whitman Ave., Metuchen, N. J.  
PERSONNEL: S. D. Wiley, Pres.; A. R. Wiley, Secy.; G. D'Eustachio, Pur. Agt.; W. B. Hutchinson, Pers. Dir.; W. F. Buchanan, Chief Engr.

**NEWARK WIRE CLOTH CO.,**  
351 Verona Ave., Newark 4, N. J.  
PERSONNEL: L. C. Campbell, Secy.

**THE NEWTON-NEW HAVEN CO.,**  
680 Third Ave., West Haven, Conn.  
PERSONNEL: W. G. Newton, Pres. & Gen. Mgr.; E. R. McKay, Secy.; B. F. English, Treas.; C. Manger, Prod. Mgr.

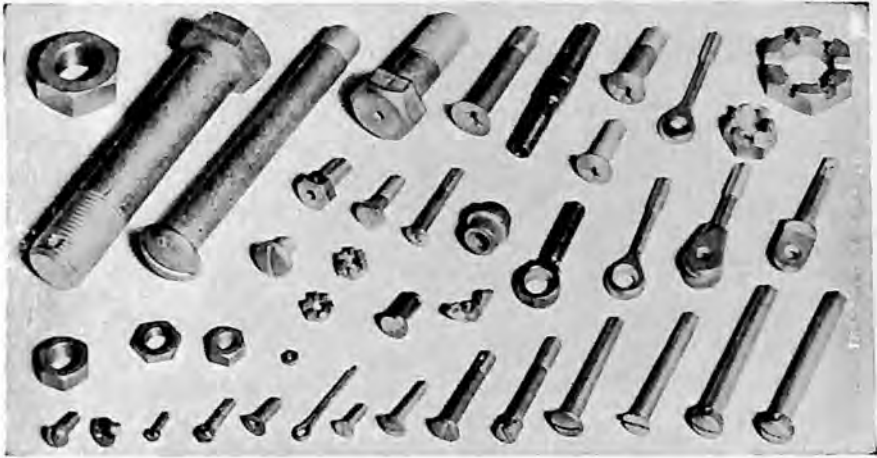

Representative aircraft fasteners made by *NATIONAL SCREW*

**RIGID INSPECTION INSURES QUALITY  
IN "NATIONAL" AIRCRAFT FASTENERS**

As a principal source of supply for aircraft fasteners, National Screw produces an exceptionally complete line of AN and NAS nuts, bolts, screws, rivets and other headed and threaded products, including many "specials" designed by individual aircraft manufacturers.

"National's" engineering and metallurgical experience, modern manufacturing and heat treating facilities, large capacity and closely integrated production layout, including our own wire mill, equip us to give our customers exceptional service.

**"NATIONAL" AVIATION PRODUCTS**

- |                                             |                                                                                          |
|---------------------------------------------|------------------------------------------------------------------------------------------|
| AN Aircraft Hex Head Bolts—AN 3 to AN 12    | AN Engine Nuts, Plain—AN 360                                                             |
| AN Clevis Bolts—AN 23 to AN 28              | AN Cotter Pins, Steel—AN 380                                                             |
| AN Eye Bolts AN 42 to AN 48                 | AN Cotter Pins, Stainless Steel—AN 380C                                                  |
| AN Hex Head Bolts AC 60 and AC-65           | AN Clevis Pins,—AN 392 to AN 398                                                         |
| AN Carriage Bolts AC 70                     | AN Steel Rivets—AN 420                                                                   |
| AN Engine Bolts—AN 73 to AN 81              | AN Steel Rivets—AN 435                                                                   |
| AN Turnbuckle Barrels AN 155                | AN Steel Rivets—AN 441                                                                   |
| AN Turnbuckle Forks AN 160 & AN 161         | AN Aviation Screws—AN 500 to AN 526                                                      |
| AN Turnbuckle Eyes AN 165 & AN 170          | AN Sheet Metal Screws—AC 530 to AC 531                                                   |
| AN Aircraft Castle Nuts—AN 310              | AN Wood Screws, Steel—AN 545-AN 550                                                      |
| AN Aircraft Plain Nuts—AN 315               | AN Wood Screws, Brass—AN 545B-AN 550B                                                    |
| AN Check Nuts—AN 316                        | AN Square Head Set Screws—AC 560                                                         |
| AN Shear Nuts—AN 320                        | NAS Close Tolerance Bolts—NAS 53 to NAS 62                                               |
| AN Plain Hex Nuts (Fine Thrd.)—AN 325       | NAS Internal Wrenching Bolts—NAS 144 to NAS 148                                          |
| AN Castle Nuts—AN 330                       | Phillips Recessed Head Machine Screws In Alloy & Carbon Steels—Also In Brass and Bronze. |
| AN Plain Hex Nuts (Coarse Thrd.)—AN 335     | Phillips Recessed Head Clevis Bolts                                                      |
| AN Aviation Hex Nuts, Steel—AN 340-AN 345   | Special Products                                                                         |
| AN Aviation Hex Nuts, Brass—AN 340B-AN 345B |                                                                                          |
| AN Aviation Wing Nuts, Steel—AN 350         |                                                                                          |
| AN Aviation Wing Nuts, Brass—AN 350B        |                                                                                          |
| AN Engine Nuts, Slotted—AN 355              |                                                                                          |

**THE NATIONAL SCREW & MFG. CO., CLEVELAND 4, O.**



**NIXON NITRATION WORKS**, Nixon, N. J.  
PERSONNEL: C. F. Schuster, Pres. & Gen. Mgr.; L. Spinx, V. Pres.; M. Breitkopf, Secy.; O. S. Blaine, Treas.; M. W. Peters, Sales Mgr.; H. A. Hendrickson, Pur. Agt.; G. Schmelter, Chief Engr.

**NORMA-HOFFMANN BEARINGS CORP.**, Stamford, Conn.

PERSONNEL: O. P. Wilson, Pres. & Treas.; H. J. Ritter, V. Pres., Secy. & Sales Mgr.; C. E. Stevens, V. Pres.-Plant Operations; C. A. Wattson, Pur. Agt.; R. A. Henderson, Pers. Dir.; D. E. Batesole, Chief Engr.

**NORTH AMERICAN ELECTRIC LAMP CO.**, 1014 Tyler St., St. Louis 6, Mo.

PERSONNEL: C. M. Rice, Pres.; E. O. Cohn, V. Pres.; L. Lander, Secy., Treas., Gen. Mgr., Sales Mgr., Pers. Dir., Adv. Mgr. & Chief Engr.; H. N. Adelstein, Prod. Mgr. & Pur. Dir.

**NORTH BROS. MFG. CO.**, Lehigh Ave. & American St., Philadelphia, Pa.

PERSONNEL: R. S. Rauch, Pres.; J. T. Fegley, V. Pres. & Treas.; E. J. Weierstall, Secy. & Sales Mgr.; W. G. Macht, Pur. Agt.

**NORTHILL CO., INC.**, 9851 Sepulveda Blvd., Los Angeles, Calif.

PERSONNEL: J. C. Garrett, Pres.; W. C. Brownlee, V. Pres.; H. W. Elliott, Secy.; E. Barlow, Treas.; E. H. Messereau, Mgr.; J. Meyer, Pur. Agt.

**NORTON CO.**, Worcester, Mass.

PERSONNEL: G. N. Jeppson, Pres.; C. S. Anderson, Secy.; M. P. Higgins, Treas.; A. B. Holmstrom, Gen. Mgr., Abrasive Div.; H. W. Dunbar, Gen. Mgr., Machine Div.; R. M. Johnson, Gen. Sales Mgr., Abrasive Div.; F. W. Smith, Gen. Sales Mgr., Machine Div.; P. Fielden, Pur. Dir.; I. W. Clark, Pers. Dir.; A. B. Fritts, Pub. Dir. & Adv. Mgr.

**NUMBERALL STAMP & TOOL CO.**

Huguenot Park, Staten Island, N. Y.

PERSONNEL: M. Bayerdorffer, Pres.; C. Zeitler, V. Pres.

## O

**THE O. K. TOOL CO., INC.**, Shelton, Conn.

**OAKITE PRODUCTS, INC.**

22 Thames St., New York 6, N. Y.

PERSONNEL: D. C. Ball, Pres.; J. A. Carter, Asst. to Pres.; D. C. Smith, D. S. Ball, H. L. Gray, V. Pres.; H. F. Cunningham, Secy.; J. Beckett, Treas.; C. F. Radley, Pub. Dir.; S. L. Remlein, Pur. Agt.

**THE OHIO CRANKSHAFT CO.**

3800 Harvard Ave., Cleveland 1, O.

PERSONNEL: W. C. Dunn, Pres. & Gen. Mgr.; G. C. Gordon, V. Pres.; F. S. Denneen, Secy. & Treas.; C. H. Kimmel, Prod. Mgr.; H. M. Hubbard, Pur. Dir.; C. E. Stemmler, Pers. Dir.; S. A. Covert, Pub. Dir.; G. W. Hurlburt, Chief Engr.

**THE OHIO PISTON CO.**

5340 Hamilton Ave., Cleveland 14, O.

PERSONNEL: C. Birnbaum, Pres.; E. J. Gutman, V. Pres.; D. P. Shaw, Secy. & Gen. Mgr.; R. G. Horsburgh, Treas.; G. Svetcoff, Prod. Mgr.

**THE OHIO SEAMLESS TUBE CO.**, Shelby, O.

PERSONNEL: W. C. Connelly, Pres. & Gen. Mgr.; W. W. Van Horn, V. Pres.; E. W. McNeill, Secy. & Treas.; H. C. Mayer, Prod. Mgr.; A. Waines, Jr., Sales Mgr.; D. C. Reagan, Pur. Dir. & Pers. Dir.; M. W. Freese, Pub. Dir. & Adv. Mgr.; R. E. Dewey, Chief Engr.

**OHIO UNITS**

515-531 Hunter Ave., Dayton, O.

PERSONNEL: A. R. Lambert, Prop.; H. L. Brump, Chief Engr.

**OHLSSON & RICE MANUFACTURING CO.**

Emery at Grande Vista, Los Angeles 23 Calif.

PERSONNEL: I. G. Ohlsson, H. T. Rice, Partners; L. B. Raymond, Prod. Mgr.; H. T. Rice, Chief Engr.

**OHMITE MANUFACTURING CO.**

4835 W. Flournoy St., Chicago, Ill.

PERSONNEL: D. T. Siegel, Gen. Mgr.; R. S. Laird, Sales Mgr.; A. Stolzenfeldt, Pur. Agt. W. C. Hart, Pers. Dir.; H. Levy, Chief Engr.

**OIL-RITE CORP.**

3466 S. 13th St., Milwaukee, Wisc.

PERSONNEL: G. H. Harris, Pres. & Gen. Mgr.; G. F. Clark, V. Pres.; A. R. Falbe, Secy. & Treas.; I. G. Chapas, Pur. Dir.; F. J. Lyden, Chief Engr.

**THE OILGEAR CO.**

1399 W. Bruce St., Milwaukee, Wisc.

PERSONNEL: H. M. Swigart, Pres.; G. H. Fobian, V. Pres.; R. D. Pakenham, Secy. & Treas.; W. G. Frasse, Sales Mgr.; E. Sherer, Pers. Dir.; M. E. Engebretson, Adv. Mgr.; E. Wiedmann, Chief Engr.

**THE OKONITE CO.**, Passaic, N. J.

PERSONNEL: F. C. Jones, Pres.; E. J. Garrigan, V. Pres. & Sales Mgr.; A. F. Metz, Treas.; D. R. Stevens, Works Mgr.; M. W. Rounds, Prod. Mgr.; R. S. Hayes, Adv. Mgr.; R. Wiseman, Chief Engr.

**OLDS ALLOYS CO.**

8686 Rheem Ave., South Gate, Calif.

PERSONNEL: R. B. Olds, Pres.; P. S. Rattle, V. Pres., Secy. & Treas.

**TINIUS OLSEN TESTING MACHINE CO.**

500 N. 12th St., Philadelphia, Pa.

PERSONNEL: T. Y. Olsen, Pres., Treas. & Gen. Mgr.; T. Olsen, II, V. Pres.; J. F. Sutton, Secy.; T. L. Richards, Sales Mgr.; C. R. Tait, Pur. Agt.; R. B. Lewis, Chief Engr.

**D. W. ONAN & SONS**

4343 Royalston Ave., Minneapolis, Minn.

PERSONNEL: D. W. Onan, Pres.; C. W. Onan, V. Pres. & Gen. Mgr.; R. D. Onan, V. Pres.; V. Aanenson, Treas.; H. F. Jacobsen, Pur. Dir.; A. Randall, Pers. Dir.; M. Fadell, Pub. Dir.; N. Tangen, Adv. Mgr.; J. C. Hoiby, Chief Engr.

**ONSRUD MACHINE WORKS, INC.**

3900 Palmer St., Chicago, Ill.

PERSONNEL: R. F. Onsrud, Pres. & Gen. Mgr.; T. W. Foote, V. Pres.; J. Knox, Secy. & Pur. Dir.; H. Krabol, Treas.; R. C. Reinhartsen, Sales Mgr.; H. C. Grondahl, Chief Engr.

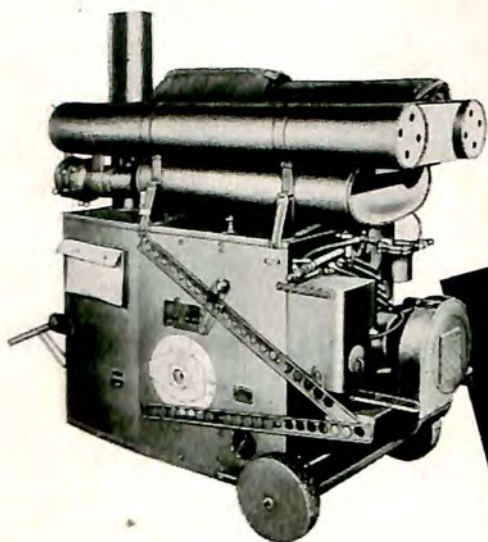

*For high achievement in the production of war equipment.*

**Designed  
for our  
Armed Forces  
everywhere**



**HERMAN NELSON  
Portable  
Self-Powered HEATER**

**Now Available For Commercial Uses**

For preheating of airplane engines, stationary engines and other equipment. This Portable Self-Powered Heater is direct fired and is available with either a gasoline engine or an electric motor. The engine or motor, integral part of the unit, operates pressure-type propeller fan, blowing air over combustion chamber and discharging through 12 in. vents at rate of 2,000 cubic feet per minute. Heating capacity 250,000 BTU per hour at 60° inlet. Weighs only 290 lbs. Available with two 12 in. waterproof, flame resisting canvas ducts for conveying heat. To each of these ducts, on some models, three 6 in. diameter ducts are added, providing six heat outlets.

Also manufacturers of Unit Heaters, Propeller Fans, Blowers and other equipment for heating and ventilating.



*Herman Nelson  
Horizontal Shaft  
Propeller Fan Type  
hiJet Heaters*



*Autovent  
Direct Drive  
Propeller Fans*



*Autovent  
Type HB Blowers*



*Herman Nelson  
Blower Fan Type  
hiJet Heaters*



**THE HERMAN NELSON CORPORATION**

**MOLINE, ILLINOIS**

**Manufacturers of Quality Heating, Ventilating and Air Conditioning Products**



**OPERADIO MANUFACTURING CO.,**  
St. Charles, Ill.

PERSONNEL: J. M. Stone, Pres.; G. R. Haase, V. Pres. & Gen. Mgr.; L. A. King, Secy. & Treas.; G. K. Brigham, Prod. Mgr.; F. D. Wilson, Sales Mgr.; E. E. Swick, Pur. Dir.; A. F. Hunecke, Pers. Dir.; E. L. Kruse, Pub. Dir. & Adv. Mgr.; J. F. McCraigh, Chief Engr.

**ORANGE ROLLER BEARING CO., INC.,**  
557 Main St., Orange, N. J.

PERSONNEL: J. A. Burden, Jr., Pres.; C. L. Ritchie, V. Pres., Treas. & Gen. Mgr.; A. F. Schaeffner, Secy.; R. J. Gales, Chief Engr.

**THE OSTER MFG. CO.,**

E. 61st at Carnegie Ave., Cleveland, O.  
PERSONNEL: R. Tewksbury, Pres., Treas. & Gen. Mgr.; A. S. Gould, V. Pres. & Sales Mgr.; H. A. Maurer, Secy.; W. Blank, Pur. Agt.; G. S. Scriven, Pers. Dir.; L. S. Newman, Pub. Dir.; R. Hyde, Chief Engr.

**J. A. OTTERBEIN,**

55-61 Hubbard St., Middletown, Conn.  
PERSONNEL: J. A. Otterbein, Prop.

**OTTO AVIATION CORP.,**

256 Liberty St., Bloomfield, N. J.  
PERSONNEL: B. R. Otto, Pres., Gen. Mgr. & Sales Mgr.; W. D. Dayton, V. Pres., Prod. Mgr. & Chief Engr.; F. Amato, Treas.; C. O. Philblad, Pur. Dir.; E. D. Mason, Pers. Dir.

**OWENS-CORNING FIBERGLAS CORP.,**  
Toledo 1, O.

PERSONNEL: H. Boeschstein, Pres.; W. P. Zimmerman, V. Pres.; C. G. Staelin, Secy.; H. R. Winkle, Treas.; B. E. Boyd, Prod. Mgr.; J. H. Thomas, Sales Mgr.; R. R. Bastian, Pur. Dir.; D. A. O'Neill, Pers. Dir.; E. C. Ames, Pub. Dir.; P. Austin, Acting Adv. Mgr.; H. R. Hogendobler, Chief Engr.

## P

**PAASCHE AIRBRUSH CO.,**  
1909 Diversey Pkwy., Chicago, Ill.

PERSONNEL: J. A. Paasche, Pres.; H. F. Reck, V. Pres., Secy. & Sales Mgr.; W. A. Sharman, Treas.; L. R. Stensland, Prod. Mgr. & Pur. Dir.; R. H. Smutzer, Adv. Mgr.; E. W. Berg, Chief Engr.

**PACIFIC-AIRMAX CORP.,** 7631 Roseberry Ave., Huntington Park, Calif.

PERSONNEL: H. A. Hartfield, Pres.; R. C. Gross, V. Pres. & Gen. Mgr.; E. S. Weiss, Treas. & Asst. Secy.; L. M. Hull, Sales Mgr. & Pub. Dir.; J. B. Marchand, Pur. Agt.; J. Davis, Pers. Dir.; A. A. Arnhy, Chief Engr.

**PACIFIC AVIATION INC.,**

927 N. Sycamore Ave., Los Angeles, Calif.  
9900 Lincoln Blvd., Los Angeles, Calif.

PERSONNEL: P. J. Brady, Pres. & Gen. Mgr.; H. V. Reynolds, V. Pres.; W. M. McIlvain, Secy. & Treas.; R. D. Bayly, Dir. Finance; S. H. Souder, Pur. Agt.; W. O. Donovan, Pers. Dir.; H. F. Frimel, Chief Engr.; H. Grove, Factory Mgr.; E. King, Gen. Supt.

**PACIFIC ENGINEERING CORP.,**

3123 San Fernando Rd., Los Angeles 41, Calif.  
PERSONNEL: R. H. Swaisgood, Pres.; H. W. Steinberger, V. Pres.; J. S. Spence, Secy. & Treas.; D. A. Imus, Pur. Dir.

**PACIFIC GEAR PLANT, WESTERN GEAR WORKS,** 11181 Long Beach Blvd., Lynwood, Calif.

PERSONNEL: P. L. Bannan, Pres.; T. J. Bannan, Exec. V. Pres.; B. A. Bannan, V. Pres.; C. Bannan, Secy.; P. Bannan, Jr., Treas.; R. Crawshaw, Gen. Mgr.; H. Niemeier, Prod. Mgr.; B. Corey, Sales Mgr.; C. Ellis, Pur. Dir.; B. Keim, Pers. Dir.; W. Hadley, Pub. Dir.; M. Meeder, Adv. Mgr.; J. Morris, Chief Engr.

**PACIFIC SCIENTIFIC CO.,**

1430 Grande Vista Ave., Los Angeles, Calif.  
PERSONNEL: W. P. Balderston, Pres.  
25 Stillman St., San Francisco, Calif.  
PERSONNEL: D. H. Grubb, V. Pres.; D. G. McAllister, Secy. & Treas.

**PACKARD ELECTRIC DIV., GENERAL MOTORS CORP.,** Warren, O.

PERSONNEL: B. N. MacGregor, Gen. Mgr.; R. E. Hatch, Prod. Mgr.; G. S. Carr, Sales Mgr., Equipment; R. J. Montgomery, Sales Mgr. Replacement; E. E. DeBolt, Pur. Dir.; J. Blair, Pers. Dir.; R. I. Williams, Pub. Dir.; H. C. Mohr, Adv. Mgr.; L. C. Wolcott, Chief Engr.

**PACKARD MANUFACTURING CORP.,**

2900 Columbia, Indianapolis, Ind.  
PERSONNEL: H. E. Caphart, Pres.; E. E. Collison, V. Pres. & Chief Engr.; W. F. Struby, Secy. & Gen. Mgr.; O. C. Roberts, Asst. Treas.; W. C. Brase, Pur. Agt.; H. Stephens, Pers. Dir.; D. V. Kennedy, Pub. Dir.

**PACKLESS METAL PRODUCTS CORP.,**

31 Winthrop Ave., New Rochelle, N. Y.  
PERSONNEL: G. M. Pettee, Pres.; M. W. McLaren, V. Pres.; R. S. Fricchette, Secy.; H. W. Cole, Treas.; S. Guarnaschelli, Prod. Mgr.; W. L. Bryde, Sales Mgr.; T. J. Callagy, Pur. Dir.

**THE PALNUT CO.,**

67 Cordier St., Irvington, N. J.  
PERSONNEL: J. R. Hotchkin, Pres.; A. H. Beggs, V. Pres.

**PANGBORN CORP.,**

250 Pangborn Blvd., Hagerstown, Md.  
PERSONNEL: T. W. Pangborn, Pres. & Gen. Mgr.; P. J. Potter, Exec. V. Pres.; J. C. Pangborn, V. Pres. & Treas.; V. F. Stine, V. Pres. & Sales Mgr.; L. L. Stouffer, Secy.; F. Kaiss, Gen. Supt.; J. D. Wise, Pur. Dir.; A. L. Gardner, Adv. Mgr.

**PANNIER BROS. STAMP CO.,**

207 Sandusky St., N. S., Pittsburgh 12, Pa.  
PERSONNEL: C. O. Pannier, Pres.; G. W. Pannier, V. Pres.; Ralph A. Pannier, Secy. & Chief Engr.; Robert A. Pannier, Treas. & Adv. Mgr.; W. J. Pannier, Sales Mgr.; A. M. Peiffer, Pur. Dir.

**PARAGON-REVOLUTE CORP.,**

79 South Ave., Rochester, N. Y.  
PERSONNEL: H. H. Sullivan, Pres. & Treas.; L. G. Booth, V. Pres.; W. L. Sullivan, Secy., Gen. Mgr. & Chief Engr.; L. G. Booth, Sales Mgr.; W. H. Wilder, Pur. Agt.

**THE PARK DROP FORGE CO.,**

735 E. 79th St., Cleveland, O.  
PERSONNEL: G. C. Gordon, Pres.; F. L. Ball, Secy. & Treas.; W. A. Humel, Gen. Mgr.; J. W. Grinder, Pur. Agt.



**PACIFIC AVIATION INCORPORATED**  
HOLLYWOOD DIVISION  
927 North Sycamore Avenue, Los Angeles, California



**PACIFIC AVIATION INCORPORATED**  
LOS ANGELES DIVISION  
9900 Lincoln Boulevard, Los Angeles, California  
**AVIATION HYDRAULIC SPECIALISTS**  
**WE BUILD THEM RIGHT THE FIRST TIME!**

**THE PARKER APPLIANCE CO.,**

17325 Euclid Ave., Cleveland, O.  
 PERSONNEL: A. L. Parker, Pres. & Treas.; H. I. Markham, V. Pres.; F. A. Rolla, Secy.; F. E. Amon, Jr., Sales Mgr.; E. G. Johnson, Pur. Agt.; W. R. Meredith, Pers. Dir.; L. H. Schmohl, Chief Engr.

**THE PARKER STAMP WORKS, INC.,**

650 Franklin Ave., Hartford, Conn.  
 PERSONNEL: H. L. Bitter, Pres., Treas. & Gen. Mgr.; K. Lingo, V. Pres.; J. T. F. Bitter, Secy., Sales Mgr. & Pur. Agt.; H. C. Bitter, Chief Engr.

**VICTOR F. PASTUSHIN CO., 4608 Blackthorne Ave., Lakewood Village, Long Beach, Calif.**

PERSONNEL: V. F. Pastushin, Pres.

**THE PAULSON TOOLS, INC., Wallingford, Conn.**

PERSONNEL: C. H. Loucks, Pres. & Gen. Mgr.; E. W. Thompson, V. Pres.; J. E. Wrinn, Secy.; J. J. Brosnan, Treas.

**THE C. F. PEASE CO.,**

2601 W. Irving Park Rd., Chicago 18, Ill.  
 PERSONNEL: T. Lord, Pres.; W. E. Pashley, V. Pres., Treas. & Sales Mgr.; S. L. Wahlstrom, Secy.; K. Nirison, Prod. Mgr.; P. E. Shaw, Pur. Dir.; W. W. Brothers, Pers. Dir., Pub. Dir. & Adv. Mgr.; H. J. Brunk, Chief Engr.

**THE PECK, STOW & WILCOX CO., Southington, Conn.**

PERSONNEL: M. J. Lacey, Pres. & Gen. Mgr.; F. L. Wilcox, V. Pres.; S. C. Wilcox, Secy. & Treas.; E. J. Murray, L. Bromel, Sales Mgrs.; W. T. Morrissey, Pur. Agt.; M. J. Wooding, Pers. Dir.; W. H. Moore, Pub. Dir.; W. L. Ludwick, Chief Engr.

**PENN RIVET CORP.,**

3rd & Huntingdon Sts., Philadelphia, Pa.  
 PERSONNEL: T. M. Searles, Pres.; J. A. Barnett, V. Pres.; E. M. Barto, Secy.; H. L. Lowe, Treas.; J. J. Clement, Pur. Agt.; J. Rieher, Chief Engr.

**PENNSYLVANIA SALT MANUFACTURING CO., 1000 Widener Bldg., Philadelphia 7, Pa.**

PERSONNEL: L. T. Beale, Pres.; L. A. Smith, V. Pres. & Treas.; Y. F. Hardcastle, G. B. Beitzel, F. C. Shaneman, V. Pres.; W. R. Over, Secy. & Asst. Treas.; H. M. Ellsworth, Adv. Mgr.; W. Penfield, Works Mgr.; V. K. O'Connor, Pers. Mgr.; N. W. James, Gen. Pur. Agt.; W. P. Drake, Sales Mgr.; F. H. Walker, Chief Engr.

**PERMATEX CO., INC.,**

1720 Ave. Y, Brooklyn, N. Y.  
 PERSONNEL: C. A. Benoit, Pres. & Treas.; L. C. Willis, V. Pres.; H. C. Fuchs, Secy.; H. J. Enders, Sales Mgr.; W. C. Corbett, Pur. Agt.; E. G. Heeren, Pers. Dir.; N. Levy, Pub. Dir.; T. L. Camp, Chief Engr.

**PERMOFLUX CORP.,**

4916 W. Grand Ave., Chicago 39, Ill.  
 PERSONNEL: L. M. Heineman, Pres.; W. E. Gilman, V. Pres.; P. Ream, Secy.; M. F. Heineman, Treas.

**THE PERMOLD CO.,**

P. O. Box 70, Medina, O.  
 PERSONNEL: E. G. Fahlman, Pres. & Gen. Mgr.; H. R. Doswell, Secy. & Prod. Mgr.; L. E. DeGroat, Sales Mgr. & Adv. Mgr.; A. Eble, Pur. Dir.; R. C. Hicks, Pers. Dir.; S. W. Jackson, Chief Engr.

**THE PERMUTIT CO.,**

330 W. 42nd St., New York 18, N. Y.  
 PERSONNEL: W. S. Robertson, Pres.; H. W. Foulds, V. Pres.; D. J. Saunders, Sales Mgr.; H. H. Wilkinson, Adv. Mgr.

**PERRY AIRCRAFT PRODUCTS CORP.,**

1127 Atlantic Ave., Brooklyn, N. Y.  
 PERSONNEL: S. Sack, Pres., Treas. & Sales Mgr.; P. Lannert, V. Pres.; M. Rubinson, Secy.; O. Gishow, Gen. Mgr. & Chief Engr.; B. Lawrence, Pur. Agt.; L. Reis, Pers. Dir.; B. Cooper, Pub. Dir.

**PERRY-AUSTEN MANUFACTURING CO.,**

Grasmere, Staten Island, N. Y.  
 PERSONNEL: F. T. Perry, Pres.; W. F. Doerflinger, V. Pres. & Treas.; A. J. Kurtz, Secy.

**PERRY METAL PRODUCTS CO. INC.,**

1125-1129 Atlantic Ave., Brooklyn, N. Y.  
 PERSONNEL: S. Sack, Pres., Treas. & Sales Mgr.; E. R. Elliott, V. Pres.; M. Rubinson, Secy.; O. R. Gischow, Gen. Mgr. & Prod. Mgr.; B. Cooper, Pur. Dir.; P. Lannert, Pers. Dir.; C. Hollinger, Chief Engr.

**PESCO PRODUCTS CO., DIV. BORG-WARNER, 11610 Euclid Ave., Cleveland 6, O.**

PERSONNEL: R. J. Minshall, Pres. & Gen. Mgr.; H. H. Brooksieker, V. Pres.-Mfg.; N. M. Forsythe, V. Pres.-Sales; C. Bissell, Secy.; J. L. Menart, Treas.; R. Swanson, Prod. Mgr.; H. H. Krause, Pur. Dir.; S. E. Voran, Adv. Mgr.; J. M. Roth, Chief Engr.

**PETROLEUM SOLVENTS CORP.,**

331 Madison Ave., New York 17, N. Y.  
 PERSONNEL: L. A. Staff, Pres. & Sales Mgr.; S. V. Hirschman, Secy. & Treas.; J. R. Minerva, Prod. Mgr.; B. H. Jacoby, Adv. Mgr. & Sales Promotion Mgr.

**PHEOLL MANUFACTURING CO.,**

5700 Roosevelt Rd., Chicago, Ill.  
 PERSONNEL: M. Phelps, Pres.; E. M. Whiting, V. Pres. & Gen. Mgr.; J. J. Schwander, Secy. & Treas.; J. A. Perry, Sales Mgr.; A. A. Schmid, Pur. Agt.; M. E. Jensen, Pers. Dir.; N. L. Marvin, Pub. Dir.; F. J. Tisch, Chief Engr.

**PHILADELPHIA DIV., BENDIX AVIATION CORP., 4700 Wissahickon Ave., Philadelphia, Pa.**

PERSONNEL: N. B. McLean, Gen. Mgr.; L. F. Lieb, Pur. Agt.; H. E. Kay, Pers. Dir.; H. Loen, Chief Engr.

**PHILCO CORP.,**

Tioga & C Sts., Philadelphia 34, Pa.  
 PERSONNEL: J. Ballantyne, Pres.; W. Balderston, V. Pres., Commercial Div.; T. A. Kennally, V. Pres. & Sales Mgr.; H. W. Butler, V. Pres. & Pers. Dir.; J. H. Carmine, V. Pres. & Adv. Mgr.; J. H. Gillies, V. Pres. & Prod. Mgr.; C. F. Steinruck, Jr., Secy.; W. R. Wilson, Treas.; R. A. Boyce, Pur. Dir.; C. H. Pitt, Pub. Dir.; P. Craig, Chief Radio Engr.

**PHILLIPS BRONZE CORP., 1460 East Washington Blvd., Los Angeles 21, Calif.**

PERSONNEL: R. W. Phillips, Pres.; R. W. Phillips, Jr., V. Pres., Gen. Mgr., Prod. Mgr. & Pur. Dir.; G. R. Price, Secy., Treas. & Sales Mgr.

**PHILLIPS MANUFACTURING CO.,**

3475 W. Touhy Ave., Chicago 45, Ill.  
 PERSONNEL: M. B. Phillips, Pres.; E. Atherton, V. Pres.; J. M. Bash, Secy.; R. A. Van Fossen, Prod. Mgr. & Tech. Dir.; I. Condell, Pur. Dir.; I. J. Rosenbloom, Adv. Mgr.; J. Holbrook, Chief Engr.

Before  
Regeneration  
0%  
Efficiency



After  
Regeneration  
80 to 90%  
Efficiency



## METAL AND TOOL RECONDITIONING SERVICE

Division of the  
Trans-American-Development Corp.

250 West 54th St., New York City  
Telephone Circle 6-1437

## NUMBERALL NUMBERING MACHINES

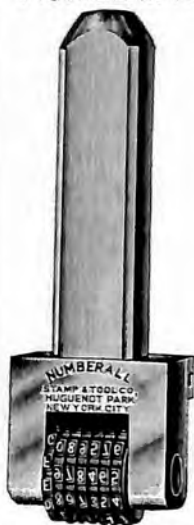

For stamping  
Figures and  
Letters into  
Metal, Fibre,  
etc.  
**SPEED UP and  
IMPROVE  
MARKING**  
Furnished in  
Sizes  
1/32" to 3/8"  
With Three to  
Twenty Wheels.  
All the  
Airplane  
Manufacturers  
use our  
Machines for  
marking  
**PARTS.**

Write us for  
Catalog.

**NUMBERALL STAMP & TOOL CO., INC.**  
Huguenot Park, Staten Island, N. Y.



## Permoflux Dynamic Headphones

Their extra sensitivity, wide frequency response and high operating efficiency provide improved intelligibility at all altitude levels.

TRADE MARK  
**PERMO-FLUX**

**PERMOFLUX CORPORATION**  
4916-22 W. Grand Ave., Chicago 39, Ill.

PIONEER MANUFACTURERS OF PERMANENT MAGNET DYNAMIC TRANSDUCERS



**THE PHOENIX OIL CO.,**

9505 Cassius Ave., Cleveland 5, O.  
 PERSONNEL: M. J. Murphy, Pres., Gen. Mgr. & Sales Mgr.; R. M. Murphy, V. Pres.; E. F. Horak, Secy., Treas. & Pur. Dir.; W. Dymia, Prod. Mgr.

**PHOTO RECORD EQUIPMENT CO.,**

511 E. Seventh St., St. Paul, Minn.  
 PERSONNEL: J. B. McGrath, Pres.; E. J. McGrath, Secy. & Pur. Agt.

**PHOTOSWITCH, INC.,**

77 Broadway, Cambridge 42, Mass.  
 PERSONNEL: A. H. Avery, Pres. & Treas.; J. A. Long, V. Pres., Secy. & Sales Mgr.; B. W. Steverman, Gen. Mgr.; F. Driscoll, Pur. Dir.; G. L. Marcy, Pers. Dir.; R. C. Crichton, Pub. Dir. & Adv. Mgr.; E. C. Thomson, Chief Engr.

**PHYSICISTS RESEARCH CO.,**

343 S. Main St., Ann Arbor, Mich.  
 PERSONNEL: E. J. Abbott, Pres.; D. E. Williamson, Gen. Mgr. & Sales Mgr.; C. Shankland, Pur. Agt.

**PIER EQUIPMENT MFG. CO.,**

1270 Milton St., Benton Harbor, Mich.  
 PERSONNEL: E. C. Fiberts, Pres.

**PIERCE PLASTICS, INC.,**

Bay City, Mich.  
 PERSONNEL: J. Pierce, Pres.; G. Freund, V. Pres.

**PIERCE & STEVENS, INC.,**

710 Ohio St., Buffalo, N. Y.  
 PERSONNEL: R. D. Stevens, Pres.; A. L. Stevens, V. Pres.; P. P. Dauscher, Treas.; G. T. Swing, Sales Mgr.; D. E. Ellis, Chief Engr.

**PILOT PROPELLERS, INC.,**

2816 Gibroy St., Los Angeles, Calif.  
 PERSONNEL: W. E. Greenwood, Pres., Gen. Mgr., Sales Mgr. & Pur. Agt.; J. B. F. Bacon, V. Pres., Treas. & Chief Engr.; H. Bacon, Secy.

**PIONEER ENGINEERING & MANUFACTURING CO., 19669 John R St., Detroit 3, Mich.**

PERSONNEL: A. M. Sargent, Pres., Gen. Mgr., Sales Mgr., Pub. Dir. & Adv. Mgr.; E. M. Beyma, V. Pres. & Prod. Mgr.; F. C. Querry, Secy. & Treas.; D. J. Lowe, Pur. Dir.; H. C. French, Chief Engr.

**PIONEER ENGINEERING WORKS, INC., 1515 Central Ave., Minneapolis 13, Minn.**

PERSONNEL: L. W. Yerk, Pres. & Gen. Mgr.; M. Ovestrud, V. Pres.; K. E. Brunsdale, Secy. & Sales Mgr.; C. H. Flingboe, Pur. Dir.; O. J. Ellertson, Adv. Mgr.; R. Heer, Chief Engr.

**PIONEER GEN-E-MOTORS,**

5841 W. Dickens Ave., Chicago, Ill.  
 PERSONNEL: D. E. Bright, Pres.; R. O. Goldberg, V. Pres.; H. Goldberg, Secy., Treas. & Chief Engr.; S. F. Hart, Gen. Mgr.; M. Hoffman, Sales Mgr.; I. M. Temen, Pur. Agt.; R. T. Plocar, Pers. Dir.; E. J. Decker, Pub. Dir.

**PIONEER PARACHUTE CO., INC.,**

168 Forest St., Manchester, Conn.  
 PERSONNEL: H. R. Mallory, Pres., Treas. & Gen. Mgr.; J. F. Smith, V. Pres. & Chief Engr.; L. H. Ford, V. Pres., Sales Mgr. & Adv. Mgr.; C. D. Cheney, Secy.; J. T. King, Prod. Mgr.; J. Schumacher, Pur. Dir.; R. D. Edwards, Pers. Dir.; J. Gross, Pub. Dir.

**PITTSBURGH PLATE GLASS CO.,**

Grant Bldg., Pittsburgh, Pa.  
 PERSONNEL: R. L. Clause, Pres.; H. B. Higgins, Exec. V. Pres.; H. B. Brown, Secy.; F. W. Currier, Treas.; J. A. Wilson, Gen. Mgr.; R. B. Tucker, Sales Dir.; M. E. Carlisle, Pur. Agt.; R. L. Gridley, Pub. Dir.; J. H. Sherts, Chief Aviation Engr.

**PITTSBURGH STEEL CO.,**

P. O. Box 118, Pittsburgh 30, Pa.  
 PERSONNEL: J. H. Carter, Pres.; A. Bindley, V. Pres.; J. U. Anderson, Secy. & Treas.; J. A. Voelker, Sales Mgr.; J. H. Phillips, Pur. Dir.; E. T. Wible, Prod. Promotion Mgr.; V. Chartener, Chief Engr.

**PLASKON DIV., LIBBEY-OWENS-FORD GLASS CO., 2112 Sylvan Ave., Toledo, O.**

PERSONNEL: W. R. Feldtmann, Compt.; J. L. Rodgers, Jr., Gen. Mgr.; E. H. Balz, Prod. Mgr.; H. Spitzer, Sales Mgr.; J. H. Jeffery, Pur. Dir. & Chief Engr.; C. J. Lemle, Pers. Dir.; W. N. Shepard, Adv. Mgr.

**PLASTIC MANUFACTURERS, INC.,**

280 Fairfield Ave., Stamford, Conn.  
 PERSONNEL: M. A. Wick, Pres.; G. C. Boyvaird, V. Pres., Sales Mgr. & Adv. Mgr.; M. Farmer, V. Pres. & Gen. Mgr.; K. D. Browne, Secy., Treas. & Pers. Dir.; G. P. Bohrer, Prod. Mgr.; J. C. Harre, Pur. Dir.; R. Macdonald, Chief Engr.

**PLOMB TOOL CO.,**

2209 Santa Fe Ave., Los Angeles, Calif.  
 PERSONNEL: M. B. Pendleton, Pres.; D. Stevens, V. Pres.; J. E. Mills, Secy.; R. W. Kerr, Treas.; M. F. Christensen, Sales Mgr.; F. Pearson, Pur. Agt.; W. Saint, Pers. Dir.; F. W. Kirwin, Pub. Dir.; A. L. Hawley, Chief Engr.

**PNEUMATIC DROP HAMMER CO.,**

200 Adams St., Braintree 84, Mass.  
 PERSONNEL: R. P. Fitzgerald, Pres. & Gen. Mgr.; E. Ward, Secy.; J. Brow, Pur. Dir.; R. E. Vergobbe, Chief Engr.

**JOSEPH POLLAK CORP.,**

85 Freeport St., Dorchester, Mass.  
 PERSONNEL: J. Pollak, Pres., Treas. & Gen. Mgr.; E. Shaw, Secy.; W. Pollak, Sales Mgr. & Pur. Agt.; G. M. Hemmer, Pers. Dir. & Pub. Dir.; R. Holub, Chief Engr.

**POLLAK MANUFACTURING CO.,**

541 Devon St., Arlington, N. J.  
 PERSONNEL: L. L. Pollak, Pres. & Sales Mgr.; C. Schlesinger, V. Pres. & Gen. Mgr.; P. Calabro, Secy. & Prod. Mgr.; G. King, Treas.; R. D. Heebner, Pur. Dir.; C. Woods, Pers. Dir. & Pub. Dir.; DeW. Conklin, Adv. Mgr.; H. E. Davies, Chief Engr.

**POOLE BROS., INC.,**

85 W. Harrison St., Chicago 5, Ill.  
 PERSONNEL: G. A. Poole, Pres.; G. A. Poole, Jr., V. Pres.; M. S. McGurn, Secy.; P. A. Johnston, Sales Mgr.; A. Reinhardt, Pur. Dir.

**THE PORCUPINE CO.,**

200 Eliot St., Fairfield, Conn.  
 PERSONNEL: J. K. Williamson, Pres.; J. R. Williamson, V. Pres.; H. H. Williamson, Secy. & Treas.

**H. K. PORTER, INC.,**

6 Ashland St., Everett, Mass.  
 PERSONNEL: H. W. Porter, Pres.; J. G. Geddes, V. Pres. & Sales Mgr.; W. A. Smith, Pur. Dir.; J. W. Geddes, Chief Engr.

*Speed Nuts perform  
more than a fastening function*

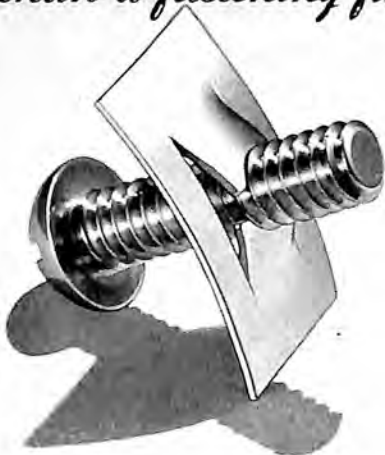

They prevent vibration loosening by means of their exclusive Double Spring-Tension Lock that ABSORBS the vibration • They are applied faster and so reduce assembly time and costs, tremendously • They avoid use of wrenches and needless handling of parts • They are even made in scores of ingenious shapes that completely eliminate two or more parts • Their wide bearing surface removes the need for spanner washers • They save from 50% to 80% in weight • If you do not have our 20 page summary catalog No. 185, write for your copy today.

**TINNERMAN PRODUCTS, INC.**

2090 FULTON ROAD, CLEVELAND 13, OHIO

Wallace Barnes Co., Ltd., Hamilton, Ontario

Simmonds Aerocessories, Ltd., London

**FASTEST THING IN FASTENINGS..** ➡ ➡ ➡

**PORTER-CABLE MACHINE CO.,**

1714 N. Salina St., Syracuse, N. Y.  
 PERSONNEL: W. A. Ridings, Pres.; D. J. Ridings, V. Pres., Secy. & Gen. Mgr.; L. B. Benham, Treas.; W. A. Papworth, Prod. Mgr.; H. L. Ramsey, Sales Mgr.; A. S. Bancroft, Pur. Dir.; S. J. Palmer, Pers. Dir.; R. M. Shurtz, Pub. Dir.; L. C. Grandy, Adv. Mgr.; A. N. Emmons, Chief Engr.

**PORTLAND CEMENT ASSOCIATION,**

33 W. Grand Ave., Chicago 10, Ill.  
 PERSONNEL: F. T. Sheets, Pres.; W. M. Kinney, V. Pres.; W. D. M. Allan, Adv. Mgr.

**J. V. G. POSEY & CO.,**

1008 S. W. Sixth Ave., Portland 4, Ore.  
 PERSONNEL: J. V. G. Posey, Pres.; G. K. Voss, Gen. Mgr.

**POSEY MANUFACTURING CO.,**

Ontario St., Hoquiam, Wash.  
 PERSONNEL: Z. M. Galloway, Pres.; T. B. Stinchfield, Secy., Treas. & Gen. Mgr.

**POTTER & JOHNSTON MACHINE CO.,**

1027 Newport Ave., Pawtucket, R. I.  
 PERSONNEL: W. W. Potter, Pres.; W. R. Winter, N. R. Earle, J. E. Makant, L. J. Orr, A. J. Fuller, J. P. Cunningham, V. Pres.; C. A. G. Birkedal, Treas.

**POULSEN & NARDON, INC.,**

2665 Leonis Blvd., Los Angeles, Calif.  
 PERSONNEL: G. Poulsen, Pres.; C. J. Nardon, V. Pres.; J. J. Strutzel, Secy. & Treas.; J. P. Strutzel, Sales Mgr. & Adv. Mgr.; E. L. Akin, Pur. Agt.

**PRATT & LAMBERT, INC.,**

75 Tonawanda St., Buffalo 7, N. Y.  
 PERSONNEL: H. E. Webster, Pres.; W. P. Werheim, V. Pres., Secy., Pub. Dir. & Adv. Mgr.; R. W. Lindsay, V. Pres., Treas. & Gen. Sales Mgr.; J. P. Nolan, Pur. Dir.

**PRATT & WHITNEY, DIV. NILES-BEMENT-POND CO., Charter Oak Blvd., West Hartford, Conn.**

PERSONNEL: C. W. Deeds, Pres. & Gen. Mgr.; H. D. Tanner, C. M. Pond, A. H. d'Arcambal, W. P. Kirk, V. Pres.; R. W. Banfield, Secy.; E. L. Morgan, Treas.; E. C. Shultz, Adv. Mgr.; F. L. Coughlin, Pur. Agt.; C. B. Perkins, Pers. Dir.

**PRECISE TOOL & MANUFACTURING CO.,**

33431 Grand River, Farmington, Mich.  
 PERSONNEL: J. A. Lutz, Pres.; E. F. Lutz, H. Ford, V. Pres.; W. G. Beaumont, Secy. & Treas.; C. E. Williams, Pur. Agt.; F. W. Edwards, Pers. Dir.; A. Grimal, Chief Engr.

**PRECISION BEARINGS, INC.,**

1706 S. Grand Ave., Los Angeles, Calif.  
 PERSONNEL: O. P. Wilson, Pres.; H. R. Swanton, V. Pres., Asst. Secy., Gen. Mgr. & Sales Mgr.; L. H. Travis, Treas.; C. M. Slocum, Pur. Agt.; E. Austen, Pers. Dir.; M. Hojrup, Pub. Dir.; R. Seidel, Engr.

**PRECISION PRODUCTS, INC.,**

420 W. Main St., Corry, Pa.  
 PERSONNEL: S. J. Irvine, Pres.; P. Waite, V. Pres. & Gen. Mgr.; L. E. Graham, Secy.; H. G. Cragg, Treas.

**PRECISION TUBE CO.,**

3824 Terrace St., Philadelphia, Pa.  
 PERSONNEL: N. H. Jack, Pres.; N. H. Jack, Jr., Prod. Mgr.; G. Turney, Sales Mgr.

**H. P. PREIS ENGRAVING MACHINE CO.,**

155 Summit St., Newark 4, N. J.  
 PERSONNEL: E. J. Preis, Gen. Mgr.; A. M. Malloy, Adv. Mgr.; J. A. Hoffmann, Chief Engr.

**PRESSED & WELDED STEEL PRODUCTS**

CO., INC., 38-61 11th St., Long Island City, N. Y.

PERSONNEL: W. E. Haskin, Pres., Treas. & Gen. Mgr.; W. C. Foster, V. Pres.; W. J. Carnes, Secy. & Sales Mgr.; J. Upton, Jr., Pur. Agt.; E. V. Ketcham, Jr., Pers. Dir.

**THE PRESSTITE ENGINEERING CO.,**

3900 Chouteau Ave., St. Louis, Mo.  
 PERSONNEL: W. C. Ferguson, Pres. & Treas.; C. H. Smith, V. Pres.; J. E. Harrison, Secy.; W. C. Snyder, Sales Mgr.; G. Knapp, Pur. Agt.; G. Sheehan, Pers. Dir.

**PREST-O-LITE BATTERY CO., INC.,**

Indianapolis, Ind.  
 PERSONNEL: J. H. McDuffee, Pres.; H. E. Komitch, V. Pres., Gen. Mgr. & Sales Mgr.; F. H. Landwehr, Secy.; J. B. Fenner, Treas.; R. A. Nowlan, Pur. Agt.; O. M. Hoyt, Pub. Dir.; N. E. Hehner, Chief Engr.

**PRESTOLE DIV.,**

4500 Detroit Ave., Toledo, O.  
 PERSONNEL: H. W. Kost, Gen. Mgr.; I. L. Carron, Sales Mgr.; C. J. Metzger, Pur. Agt.; N. H. Fender, Chief Engr.

**PRESTON MACHINE TOOL SALES CO.,**

2018 Capitol Ave., Houston, Tex.  
 PERSONNEL: J. C. Preston, Gen. Mgr.; P. A. Bob, Chief Engr.

**PRINTLOID, INC.,**

93 Mercer St., New York 12, N. Y.  
 PERSONNEL: G. Margolish, Pres.; M. Margolish, V. Pres.; S. Helfman, Secy.; M. Lome, Prod. Mgr.; L. Green, Pur. Dir.; C. Legler, Chief Engr.

**PROCUINER SAFETY CHUCK CO.,**

18 S. Clinton St., Chicago 6, Ill.  
 PERSONNEL: H. G. Procuinier, Pres.; J. A. McConnell, Secy.

**PRODUCTION TOOL & DIE CO., INC.,**

572 St. James Ave., Springfield, Mass.  
 PERSONNEL: R. J. Gaudreau, Pres., Treas. & Gen. Mgr.; E. R. Gaudreau, V. Pres. & Secy.; M. W. Duclos, Sales Mgr.; G. F. Russell, Pur. Agt.

**PRODUCTS ENGINEERING CO.,**

9045 Wilshire Blvd., Beverly Hills, Calif.  
 PERSONNEL: L. A. Spievak, Owner; J. P. Vogel, Gen. Mgr.; C. Laver, Prod. Mgr.; J. Pensack, Sales Mgr. & Adv. Mgr.; E. Rembaum, Pur. Dir.; E. French, Pers. Dir.; H. Feldman, Chief Engr.

**PULMOSAN SAFETY EQUIPMENT CORP.,**

176 Johnson St., Brooklyn, N. Y.  
 PERSONNEL: F. Wahlert, Pres.; E. W. Burke, Treas.

**PUMP ENGINEERING SERVICE CORP.,**

PESCO DIV. OF BORG-WARNER, Cleveland, O.  
 PERSONNEL: R. J. Minshall, Pres. & Gen. Mgr.; H. H. Brooksieker, V. Pres.; C. Bissell, Secy.; J. L. Menart, Treas.; N. M. Forsythe, Sales Mgr.; H. H. Krause, Pur. Agt.; S. E. Voran, Pub. Dir.; J. M. Roth, Chief Engr.

**PURITAN CO., INC.,**

573 Lyell Ave., Rochester, N. Y.  
 PERSONNEL: A. Beach, Pres. & Treas.; J. F. Bush, Jr., V. Pres., Gen. Mgr. & Sales Mgr.; C. S. Wilcox, Secy.; M. F. Radtke, Pur. Agt.; C. M. White, Chief Engr.



*Compare This New Speed with the Old Way  
True-Surfacing Freehand with*

## **PORTER-CABLE Wet-Belt SURFACER**

● The two faces of the aluminum casting shown must be finished at exact right angles, true-flat and glass smooth. With a Porter-Cable Wet-Belt Surfacer, these rigorous requirements are met with only one application of each face to the belt, and without mounting the piece in a fixture!



● In the aircraft industry, this amazingly adaptable precision tool replaces or supplements many operations on millers, surface grinders, planers, shapers. Learn more about it! Send for our new booklet, **A NEW PRECISION MACHINING METHOD**, virtually a text-book on one of the most important machining helps to come out in years.

**PORTER-CABLE** MACHINE COMPANY

1930 N. SALINA ST., SYRACUSE, N. Y.

## **MOORE EASTWOOD & CO.**

DAYTON

OHIO.

**Manufacturers of Airplane Parts,  
Especially Armament Equipment  
for past 20 years — Contractors  
For Army, Navy, and Leading  
Airplane Companies.**

**PURITAN COMPRESSED GAS CORP.,**  
2012 Grand Ave., Kansas City 8, Mo.  
PERSONNEL: P. B. Francis, Pres.; R. E. Stone,  
Prod. Mgr.; R. E. Koons, Sales Mgr.; M. L.  
Anderson, Pur. Dir.; E. P. Muller, Adv. Mgr.;  
C. H. Welty, Chief Engr.

**PURULATOR PRODUCTS, INC.,**  
365 Frelinghuysen Ave., Newark 5, N. J.  
PERSONNEL: R. R. Layte, Pres.; L. W.  
Williams, V. Pres. & Chief Engr.; E. B.  
Headden, F. P. Herman, V. Pres.; W. M. Kane,  
Asst. Secy.; H. W. Thogode, Treas.; L. E.  
Welch, Pur. Dir.

**THE PYLE-NATIONAL CO.,**  
1334 N. Kostner Ave., Chicago 51, Ill.  
PERSONNEL: J. A. Amos, Pres.; R. D. Grant,  
A. N. Martin, V. Pres.; N. R. Emery, Secy. &  
Treas.; W. A. Ross, Sales Mgr.; H. A. Redmon,  
Pur. Dir.; W. A. Wulle, Adv. Mgr.; T. E.  
McDowell, Chief Engr.

**PYRENE MANUFACTURING CO.,**  
560 Belmont Ave., Newark 8, N. J.  
PERSONNEL: E. A. Clapp, Pres. & Treas.; E. J.  
Waring, V. Pres. & Gen. Mgr.; E. G. Weed,  
V. Pres. & Secy.; D. R. Gamble, Prod. Mgr.;  
G. H. Boucher, Gen. Sales Mgr.; H. L. Fried-  
auf, Pur. Dir.; G. H. Phillips, Pers. Dir.; T. O.  
Young, Pub. Dir. & Asst. Adv. Mgr.; F. A.  
Dodelin, Chief Engr.

**PYROXYLIN PRODUCTS, INC.,**  
4851 S. St. Louis Ave., Chicago, Ill.  
PERSONNEL: P. S. Fawkes, Pres.; W. C. Wilson,  
V. Pres.; C. E. Fawkes, Secy. & Sales Mgr.;  
I. Erhardt, Pur. Agt.

## Q

**QUALITY ELECTRIC CO.,** 1235 E. Olympic  
Blvd., Los Angeles, Calif.  
PERSONNEL: J. O. Case, Pres., Gen. Mgr., Sales  
Mgr. & Pub. Dir.; A. W. Wotkyns, V. Pres.,  
Treas. & Pers. Dir.; W. R. Frampton, Secy.;  
J. M. Wells, Pur. Agt.; C. C. Adams, Chief  
Engr.

## R

**R-B-M MANUFACTURING CO.,**  
Logansport, Ind.  
PERSONNEL: A. E. Holton, Pres.; R. L. Dash-  
ner, V. Pres. & Gen. Mgr.; R. G. Schoel, Secy.  
& Treas.; R. T. Pierson, Sales Mgr.; A. W.  
Tuttle, Pur. Agt.; W. J. Canavan, Pers. Dir.;  
H. H. Clayton, Chief Engr.

**RCA VICTOR DIV., RADIO CORP. OF  
AMERICA,** Front & Cooper Sts.,  
Camden, N. J.  
PERSONNEL: R. Shannon, Pres.; M. Brunet, V.  
Pres.; F. H. Corregan, Secy.; E. F. Haines,  
Treas.; H. M. Hucke, Sales Mgr.-Aviation  
Prod.; P. D. Wilson, Pur. Agt.; E. C. Morse,  
Pers. Dir.; T. F. Joyce, Pub. Dir.; J. B. Cole-  
man, Chief Engr.

**R E F AIRCRAFT CORP.,** Syosset, N. Y.  
PERSONNEL: L. E. Faust, Pres.; R. H. Faust,  
V. Pres.; M. Rochman, Secy.; A. R. Willis, Jr.,  
Treas.; C. D. Birmingham, Pur. Agt.

**RADEL LEATHER MFG. CO.,**  
445 Wilson Ave., Newark, N. J.  
PERSONNEL: F. J. Radel, Pres.; D. F. O'Connor,  
V. Pres.; C. B. Schubert, Secy. & Treas.; R. H.  
Cudlipp, Sales Mgr.; A. H. Miller, Pur. Dir.

**RADIANT LAMP CORP.,**  
260 Sherman Ave., Newark, N. J.  
PERSONNEL: J. Glassberg, Pres.; L. Weil, V.  
Pres.; M. W. Weil, Secy. & Treas.; A. B.  
Slocum, Pur. Agt.; A. F. Bleiweiss, Chief Engr.

**RADIATOR SPECIALTY CO.,**  
Charlotte, N. C.  
PERSONNEL: I. D. Blumenthal, Pres.; H. F.  
Meltsner, V. Pres. & Sales Mgr.; S. Kraft,  
Secy.; M. A. Brown, Treas. & Gen. Mgr.; W. P.  
Finley, Jr., Pur. Dir.

**RADIO CONDENSER CO.,** Camden, N. J.  
PERSONNEL: S. S. Cramer, Pres.; R. E. Cramer,  
V. Pres.; W. W. Paul, Secy. & Treas.; W. J.  
May, Sales Mgr.; J. W. Willard, Pur. Agt.;  
S. McKenty, Pers. Dir.; J. S. Robb, Chief  
Engr.

**RADIO FREQUENCY LABORATORIES, INC.,**  
Boonton, N. J.  
PERSONNEL: R. W. Seabury, Jr., Pres.; R. S.  
Corbin, V. Pres., Sales Mgr. & Pur. Agt.; B. E.  
Holley, Secy. & Treas.; L. R. Damon, Chief  
Engr.

**RADIO NAVIGATIONAL INSTRUMENT  
CORP.,** 500 Fifth Ave., New York, N. Y.  
PERSONNEL: E. J. Simon, Pres.; F. A. Kolster,  
V. Pres.; M. May, Secy.; H. W. Pfahler, Treas.;  
L. Freed, Pur. Agt.; R. Muniz, Chief Engr.

**RADIO RECEPTOR CO. INC.,**  
251 W. 19th St., New York 11, N. Y.  
PERSONNEL: L. Arnsen, Pres. & Sales Mgr.;  
J. M. Torr, Asst. to Pres. & Adv. Mgr.; H.  
Cohn, V. Pres., Treas. & Gen. Mgr.; H. R.  
Zeamans, Secy.; W. Ostrove, Pur. Dir.; I. B.  
Seidler, Pers. Dir.; E. D. Gibbs, Chief Engr.

**RAMSEY ACCESSORIES MFG. CORP.,**  
3693 Forest Park Blvd., St. Louis, Mo.  
PERSONNEL: J. A. Ramsey, Pres.; H. Ramel,  
V. Pres.; L. A. Ramsey, Secy.; R. T. Dubois,  
Prod. Mgr.; O. C. Holaday, Sales Mgr.; W. G.  
Myers, Adv. Mgr.; C. A. Marion, Sr., Chief  
Engr.

**RANDALL GRAPHITE PRODUCTS CORP.,**  
609 W. Lake St., Chicago, Ill.  
PERSONNEL: R. H. Whiteley, Pres. & Gen.  
Mgr.; W. P. Thacher, V. Pres.; E. A. Zim-  
merman, Secy. & Treas.; M. E. Clark, Sales  
Mgr.; W. E. Dickerson, Pur. Agt.; C. E.  
Lowgren, Pers. Dir.; M. G. Miller, Pub. Dir.;  
H. B. Hostetler, Chief Engr.

**RANDOLPH FINISHING PRODUCTS CO.,**  
Carlstadt, N. J.  
PERSONNEL: W. G. Randolph, Pres.; M. J.  
Fenton, Sales Mgr.; A. B. Long, Chief Engr.

**N. RANSOHOFF, INC.,** Township St., Elm-  
wood Pl., Cincinnati, O.  
PERSONNEL: N. Ransohoff, Pres.; M. B.  
Ransohoff, V. Pres.; J. W. Freiberg, Secy.; L. F.  
Weston, Treas.; R. C. Wigger, Gen. Mgr.; W.  
E. Niesslein, Chief Engr.

**RAY DAY PISTON CORP. OF DETROIT,**  
6656 Walton Ave., Detroit, Mich.  
PERSONNEL: R. E. Day, Pres.; D. W. Bay, V.  
Pres. & Sales Mgr.; J. M. Ready, Secy. &  
Treas.; M. Franklin, Pur. Agt.; G. Bliss, Pers.  
Dir.

**RAY-O VAC CO.,**  
2317 Winnebago St., Madison, Wisc.  
PERSONNEL: W. W. Cargill, Pres.; D. W.  
Tyrrell, V. Pres. & Gen. Mgr.; W. A. Hastings,  
Secy.; E. B. Ott, Treas.; L. G. Berigan, Prod.  
Mgr.; N. D. Veal, Sales Mgr.; G. P. Wieden-  
beck, Pur. Dir.; S. L. Rorge, Pers. Dir.; J. V.  
Contin, Pub. Dir. & Adv. Mgr.; H. B. Hileman,  
Chief Engr.



AIR CYLINDERS



AIRCRAFT RIVITORS

**For Today and Tomorrow**  
**T-J** FOR  
*Tough Jobs*

Whether it's a job for Rivitors  
 ...hydraulic cylinders... air cy-  
 linders... cutters... Clinchors... or  
 air controls... you can count on  
 T-J for unbeatable efficiency, ac-  
 curacy and dependable perform-  
 ance! All T-J products built to  
 precise standards of manufac-  
 ture... rigidly inspected... backed  
 by practical-minded experi-  
 enced engineering. In planning  
 a better production set-up for  
 better products... specify T-J  
 Quality! Write for bulletins.  
 The Tomkins-Johnson Co.  
 Jackson, Mich.



HYDRAULIC CYLINDERS

**TOMKINS-JOHNSON**



**RAYMOND MFG. CO., DIV. ASSOCIATED  
SPRING CORP., 226 S. Center St.,  
Corry, Pa.**

PERSONNEL: F. F. Barnes, Pres.; F. E. Whittlesey, V. Pres.; G. Gauffreau, Secy.; C. H. Holden, Treas. & Pur. Agt.; E. W. Feldt, Gen. Mgr.; J. E. Mount, Sales Mgr.; R. Bachofner, Pers. Dir.

**READING BATTERIES, INC.,**

P. O. Box 916, Reading, Pa.

PERSONNEL: D. R. Bomberger, Pres. & Treas.; J. T. Moore, Jr., Secy. & Gen. Mgr.; H. Peck, Sales Mgr. & Pub. Dir.; C. G. Reetz, Pur. Agt. & Chief Engr.

**READING CHAIN & BLOCK CORP.,**

2100 Adams St., Reading, Pa.

PERSONNEL: F. A. Howard, Pres. & Pur. Agt.; P. K. Howard, V. Pres.; F. M. Howard, Secy. & Treas.; A. K. Hartzell, Chief Engr.

**REDA MANUFACTURING CO.,**

311 Page Blvd., Springfield, Mass.

PERSONNEL: D. B. Gish, Pres. & Treas.; S. A. Tetreault, V. Pres. & Gen. Mgr.; K. T. Gish, Secy.; H. A. Johnson, Sales Mgr.; P. Dir. & Pub. Dir.; C. A. Badore, Pur. Agt.; H. M. Richter, Chief Engr.

**REED-PRENTICE CORP.,**

677 Cambridge St., Worcester, Mass.

PERSONNEL: R. E. Thompson, Pres. & Treas.; F. W. McIntyre, V. Pres. & Gen. Mgr.; E. Connolly, Secy.; C. W. Gallagher, Asst. Sales Mgr.; R. P. Harrington, Pur. Agt.; H. Mongeau, Pers. Dir.; E. K. Heath, Pub. Dir.; R. L. Rougemont, Chief Engr.

**REED & PRINCE MFG. CO.,**

1 Duncan Ave., Worcester, Mass.

PERSONNEL: C. T. Reed, Pres.; E. C. Boyd, V. Pres. & Sales Mgr.; R. E. Borgeson, Secy.; A. Reed, Treas.; C. A. Thompson, Pur. Agt.

**REEVES PULLEY CO.,**

Columbus, Ind.

PERSONNEL: G. L. Reeves, Pres.; P. B. Reeves, V. Pres. & Prod. Mgr.; C. M. Reeves, V. Pres.; R. F. Reeves, Secy., Treas. & Gen. Mgr.; J. Dowell, Pur. Dir.; J. Sullivan, Pers. Dir.; M. Winterberg, Adv. Mgr.; D. B. Rush, Chief Engr.

**REIKER INSTRUMENT CO.,**

1919 Fairmount Ave., Philadelphia, Pa.

PERSONNEL: M. A. Ricker, Pres.

**REMINGTON RAND INC.,**

Johnson City, N. Y.

PERSONNEL: H. A. Schuler, V. Pres.

Ilion, N. Y.

PERSONNEL: B. O. Reuther, V. Pres.

**REPUBLIC STEEL CORP.,**

General Offices-Republic Bldg., Cleveland 1, O.

PERSONNEL: T. M. Girdler, Chairman; R. J. Wysox, Pres.; N. J. Clarke, V. Pres.-Sales; C. M. White, V. Pres.-Operations; D. B. Gillies, V. Pres.; W. W. Hancock, V. Pres., Secy. & Treas.; P. F. Boyer, V. Pres.-Comptroller; J. M. Schlendorf, Asst. V. Pres.-Sales; C. W. Ruth, Dir. Adv.; J. A. Voss, Dir. of Ind. Rel.; C. A. Ilgenfritz, Mgr. Pur. & Ray Materials; E. C. Smith, Chief Met.; R. H. Bahney, F. M. Darner, Chief Engrs.

**RESISTOFLEX CORP.,**

Belleville, N. J.

PERSONNEL: E. S. Peierls, Pres., Treas. & Gen. Mgr.; H. E. Krels, V. Pres. & Sales Mgr.; C. E. Stretton, Secy. & Pur. Dir.; S. Sinding, Prod. Mgr. & Pers. Dir.; W. MacWilliams, Acting Chief Engr.

**REVERE COPPER & BRASS INC.,**

230 Park Ave., New York 17, N. Y.

PERSONNEL: C. D. Dallas, Pres.; J. J. Russell, Treas.; R. E. Falk, Prod. Mgr.; R. G. Scott, Sales Mgr.; H. A. Schlieder, Pur. Dir.; C. S. Phillips, Pers. Dir.; N. A. Schuele, Pub. Dir. & Adv. Mgr.

**REVOLVATOR CO.,**

86th St., North Bergen, N. J.

PERSONNEL: H. S. Germond, Pres. & Gen. Mgr.; A. D. Germond, V. Pres.; P. D. Germond, Secy., Prod. Mgr. & Chief Engr.; H. S. Germond, III, Treas., Sales Mgr. & Adv. Mgr.; J. F. Taylor, Pur. Dir.

**REYNOLDS METALS CO., ALUMINUM &  
PARTS DIV., Plant #14, 2000 South 9th  
St., Louisville, Ky.**

PERSONNEL: R. S. Reynolds, Sr., Pres.; W. G. Reynolds, V. Pres.; R. S. Reynolds, Jr., Treas.; D. P. Reynolds, Sales Mgr.; P. Winnia, Pur. Dir.

**JAMES H. RHODES & CO.,**

157 W. Hubbard St., Chicago 10, Ill.

PERSONNEL: E. R. Murphey, Pres.; L. K. Rimer, Exec. V. Pres.; W. A. Burns, Jr., H. L. Geddes, A. N. Sudduth, I. M. Slepka, E. B. Baruch, V. Pres.; G. W. Hirsch, Pers. Dir.; R. A. Kribs, Adv. Mgr.; O. F. Fischer, Chief Engr.

**RICHLAND AUTO PARTS CO.,**

Mansfield, O.

PERSONNEL: O. P. Crouse, Gen. Mgr.; J. O. Crouse, Sales Mgr.; Pers. Dir. & Chief Engr.

**RICHMOND RING CO., Souderton, Pa.**

PERSONNEL: E. Trainer, Pres.; E. H. Burk, Secy. & Gen. Mgr.

**RITTER CO., INC.,**

400 West Ave., Rochester 11, N. Y.

PERSONNEL: E. J. Ries, Pres.; W. S. Herson, V. Pres.; F. Ritter Shumway, V. Pres., Secy. & Treas.; V. A. Noel, Sales Mgr.; R. J. Rosa, Pur. Agt.; H. C. Brownlee, Pers. Mgr.; E. Hurlburt, Adv. Mgr.; E. D. Beebe, Chief Engr.

**RIVETT LATHE & GRINDER INC.,**

18 Riverview Rd., Brighton, Mass.

PERSONNEL: T. S. Ross, Pres. & Gen. Mgr.; F. S. Moulton, V. Pres.; A. B. Hunt, Treas. & Sales Mgr.; H. E. Baker, Pur. Agt.

**ROBBINS & MYERS, INC., Springfield, O.**

PERSONNEL: W. S. Quinlan, Pres., Treas. & Gen. Mgr.; C. H. Clark, V. Pres. & Sales Mgr.; J. H. Horstman, V. Pres. & Secy.; F. S. Brady, Pur. Agt.; W. A. Hill, Pers. Dir.; F. W. Burmeister, Pub. Dir.; T. C. Lloyd, Chief Engr.

**ROBERTS & MANDER STOVE CO.,**

237 Jacksonville Rd., Hathoro, Pa.

PERSONNEL: H. S. Minster, Pres.; R. S. Agge, V. Pres. & Sales Mgr.; W. A. Jaeger, Secy. & Treas.; J. G. Andrews, Prod. Mgr.; G. Kelley, Pur. Dir.; J. Christ, Pers. Dir.; R. Sellers, Chief Engr.

**ROBERTSHAW THERMOSTAT CO.,**

Youngwood, Pa.

PERSONNEL: J. A. Robertshaw, Pres. & Gen. Mgr.; C. W. Robertshaw, V. Pres.; W. H. Steffler, Asst. Secy. & Asst. Treas.; G. P. Grace, Prod. Mgr.; F. H. Post, Sales Mgr.; W. D. Miller, Pur. Dir.; G. McClaren, Pers. Dir.; V. Weber, Chief Engr.

# FORGINGS



*of steel, aluminum  
and other alloys!*

For over fifteen years, the Tube Turns organization has been recognized for its ability to originate and employ new forging methods that handle difficult operations with accuracy and speed that were impossible under older forging procedures. Your inquiry on any forgings of a contract nature, for war-time production or future plans, will be accepted in confidence and have our immediate attention. Simply write TUBE TURNS (Inc.) Louisville, Ky.

## TUBE TURNS

*Forgings for Industry*

|                          |                            |                            |                         |
|--------------------------|----------------------------|----------------------------|-------------------------|
| <i>Aeronca</i>           | <i>Consolidated-Vultee</i> | <i>Hamilton</i>            | <i>Solar Aircraft</i>   |
| <i>Beech Aircraft</i>    | <i>Continental Motor</i>   | <i>Lockheed</i>            | <i>Stinson Aircraft</i> |
| <i>Bell Aircraft</i>     | <i>Curtiss-Wright</i>      | <i>Glenn L. Martin</i>     | <i>Vega Airplane</i>    |
| <i>Bellanca</i>          | <i>Douglas</i>             | <i>North American</i>      | <i>Vought-Sikorsky</i>  |
| <i>Bendix Aviation</i>   | <i>Fairchild</i>           | <i>Pratt &amp; Whitney</i> | <i>Waco Aircraft</i>    |
| <i>Boeing</i>            | <i>Fleetwings Inc.</i>     | <i>Ryan Aeronautical</i>   | <i>Wright</i>           |
| <i>Brewster Aircraft</i> | <i>Ford Motor Co.</i>      |                            |                         |
| <i>Cessna Aircraft</i>   | <i>Goodyear Aircraft</i>   |                            |                         |



## KARDEX users crowd the sky



What better proof that "Fact-Power" in the plant helps put horse-power in the air than such a list as this . . . every one currently using the Kardex Method of Visible Record Control? With its exclusive Graph-A-Matic signalling system, Kardex offers the instantaneous visibility of facts needed for effective control of production, personnel administration, materials and machine load. Why not let one of our Systems

Technicians study *your* control needs and recommend the most efficient, low cost way of meeting them?

### A FREE OFFER

The Aircraft Manufacturers' *Management Controller* contains clear-cut, unbiased studies of successful systems of control that are applicable in *your* operations. Write, phone or wire our nearest Branch Office and ask for MC-686.



COPYRIGHT, 1944

**SYSTEMS DIVISION**  
**REMINGTON RAND**  
**BUFFALO 3, NEW YORK**

**Announcing**

**These additional models  
for 1944 production**

- C75 — 4 cyl. 75 horsepower
- C85 — 4 cyl. 85 horsepower
- C115 — 6 cyl. 115 horsepower
- C125 — 6 cyl. 125 horsepower
- C140 — 6 cyl. 140 horsepower

Like all Continental Red Seal Engines these new models can be depended upon to develop their full-rated horsepower.

**Back the Attack  
Buy War Bonds and  
Keep Them**

***Continental Motors Corporation***

*Aircraft Engine Division*  
MUSKEGON MICHIGAN



**H. H. ROBERTSON CO.,**  
2400 Farmers Bank Bldg., Pittsburgh,  
Pa.

PERSONNEL: H. H. Robertson, Pres.; J. H. Young, V. Pres. & Gen. Mgr.; J. K. Davis, Secy.; A. G. Shurlock, Treas.; F. C. Russell, Sales Mgr.; J. Morrow, Pur. Agt.; C. Bianchi, Pers. Dir.; H. B. Winslow, Pub. Dir.; J. A. Cartright, Chief Engr.

**ROCHESTER MFG. CO., INC.,**  
100 Rockwood St., Rochester, N. Y.

PERSONNEL: W. Mulcahy, Pres., Treas. & Gen. Mgr.; C. L. Hastings, V. Pres. & Adv. Mgr.; W. W. Hastings, Secy.; H. A. Kemsley, Prod. Mgr.; L. I. Hall, Sales Mgr. & Pub. Dir.; L. A. Mumford, Pur. Dir.; J. Wright, Pers. Dir.; G. E. Ford, Chief Engr.

**ROCHESTER ROPES, INC.,**  
Jamaica, New York

PERSONNEL: W. L. Rochester, Pres.; W. L. Rochester, Jr. V. Pres.; H. Schroeder, Secy.; T. J. Burke, Sales Mgr.; E. Heffernan, Pur. Dir.; C. A. Castillo, Chief Engr.

**ROCKBESTOS PRODUCTS CORP.,**  
50 Mitchell Rd., New Haven, Conn.

PERSONNEL: A. G. Newton, Pres.; B. H. Reeves, V. Pres.; W. C. Armstrong, Secy. & Treas.; H. O. Anderson, Gen. Sales Mgr.; E. L. Alvord, Pur. Agt.; K. A. Redfield, Pub. Dir.; H. S. Moore, Chief Engr.

**ROCKY MOUNTAIN STEEL PRODUCTS, INC.,** 1360 Wall St., Los Angeles 15, Calif.

PERSONNEL: E. C. LeMunyon, Pres. & Gen. Mgr.; G. L. LeMunyon, V. Pres.; L. E. Hurley, Secy. & Treas.; A. L. Robb, Chief Engr.

**RODDIS LUMBER & VENEER CO.,**  
Marshfield, Wisc.

PERSONNEL: H. Roddis, Pres. & Gen. Mgr.; F. M. Roddis, V. Pres.; J. Hobelsberger, Secy.; R. T. Beggs, Treas.; C. G. Yerkes, Sales Mgr.; H. E. Wenzel, Pur. Agt.; A. C. Barnes, Pers. Dir.; W. Roddis, Chief Engr.

**JOHN A. ROEBLING'S SONS CO.,**  
640 S. Broad St., Trenton 2, N. J.

PERSONNEL: W. A. Anderson, Pres.; C. G. Williams, Exec. V. Pres. & Gen. Mgr.; C. R. Tyson, Secy. & Treas.; J. D. Thompson, Works Mgr.; E. C. Low, Sales Mgr.; L. H. Van Dike, Pur. Dir.; J. A. Turner, Pers. Dir.; F. J. Maple, Adv. Mgr.; C. M. Jones, Dir. of Engr.

**ROGERS PRODUCTS CO., INC.,**

3711 Hudson Blvd., Jersey City, N. J.  
PERSONNEL: C. L. Zabriskie, Pres.; H. Albertine, V. Pres. & Chief Engr.; J. A. Miller, Secy. & Treas.; C. S. Gill, Sales Mgr.; J. Daly, Pur. Agt.

**ROHLM MANUFACTURING CO., INC.,**  
561 E. 18th St., Erie, Pa.

PERSONNEL: J. R. Dunnihoo, Pres. & Gen. Mgr.; M. H. Adams, V. Pres.; H. N. Dunnihoo, Secy.; S. Licklider, Treas.; G. E. Paulson, Prod. Mgr.; J. W. Hellwege, Pur. Dir.; E. F. Sarver, Chief Engr.

**ROHM & HAAS CO.,**

222 W. Washington Sq., Philadelphia 5, Pa.

PERSONNEL: O. Haas, Pres.; E. C. B. Kifsopp, V. Pres.; S. C. Kelton, Secy.; D. Merriwether, Treas.; D. S. Frederick, Sales Mgr.; P. J. Clarke, Pur. Dir.; H. R. Hey, Pers. Dir.; E. Greene, Plastics Pub. Dir. & Adv. Mgr.

**ROHR AIRCRAFT CORP.,**  
Chula Vista, Calif.

PERSONNEL: F. H. Rohr, Pres. & Gen. Mgr.; J. E. Rheim, Exec. V. Pres.; B. P. Lester, V. Pres.-Finance; F. H. Nottbusch, V. Pres., Secy. & Gen. Counsel; G. M. Harrington, Treas.; E. M. Lacey, Asst. to Gen. Mgr.; E. J. Beaugrand, Employment Mgr.; H. R. Wiseman, Ind. Rel. Mgr.; F. E. McCreery, Chief Engr.; K. W. Maynard, Gen. Works Mgr.; J. H. Stromberg, Pur. Agent; I. C. White, Adv. Mgr.

**ROLLER BEARING CO. OF AMERICA,**  
Trenton, N. J.

PERSONNEL: R. E. Trainer, Pres.; F. H. Trainer, V. Pres.; J. J. Trainer, Secy.; E. C. Trainer, Treas.; J. K. Stahl, Sales Mgr.; R. J. McCoy, Pur. Dir.; L. R. Murphy, Adv. Mgr.; V. L. Barr, Chief Engr.

**ROMEC PUMP CO.,**

Abbe & Taylor Sts., Elyria, O.  
PERSONNEL: R. H. McQuat, Pres.; C. F. Shuler, Secy. & Treas.; A. A. Andersen, Prod. Mgr.; F. H. Clewers, Sales Mgr.; L. D. Acheson, Pur. Agt.; M. L. Mathews, Pers. Dir.; W. L. Davis, Chief Engr.

**GEO. D. ROPER CORP.,**  
Blackhawk Park Ave., Rockford, Ill.

PERSONNEL: S. H. Hobson, Pres.; F. K. Lawson, V. Pres. & Treas.; J. P. Curtin, Secy.; H. N. Morse, Prod. Mgr.; S. C. Cochran, Pur. Dir.; S. Weill, Pers. Dir.; E. L. Hollingsworth, Adv. Mgr.; A. E. Jacobs, Chief Engr.

**A. W. ROSEN & CO.,**

1801 First Ave., New York, N. Y.  
PERSONNEL: A. W. Rosen, Pres.; S. Rubinsky, Secy. & Treas.

**ROUGH WEAR CLOTHING CO.,**  
93 Worth St., New York, N. Y.

PERSONNEL: I. Kirschenbaum, Pres., Treas. & Gen. Mgr.; H. Sander, V. Pres. & Sales Mgr.; M. S. Jacobs, Secy.

**ROXALIN FLEXIBLE FINISHES INC.,**  
800 Magnolia Ave., Elizabeth, N. J.

PERSONNEL: L. Roon, Pres.; A. Miesem, V. Pres.; R. V. Kirk, Secy.; K. Butler, Treas.; E. D. Horgan, Sales Mgr.; C. W. Scott, Pub. Dir.; A. B. Marsh, Chief Engr., Aircraft Products.

**RUCKSTELL BURKHARDT MANUFACTURING CORP.,** 999 S. Main St., Elmita, N. Y.

PERSONNEL: J. J. Brooks, Pres.; C. H. Wadsworth, V. Pres. & Treas.; W. M. Huber, Secy.; V. P. Mathews, Factory Mgr.; M. N. Rand, Pur. Agt.; R. S. Phillips, Pers. Dir.; H. L. Burkhardt, Chief Engr.

**RUSSELL, BURDSALL & WARD BOLT AND NUT CO.,** Port Chester, N. Y.

PERSONNEL: E. Ward, Pres.; W. L. Ward, V. Pres.; R. L. Burdsall, Secy.; S. N. Comly, Treas.; H. O. McCully, Sales Mgr. & Adv. Mgr.; P. M. Culyer, Pur. Dir.

**THE RUSSELL MANUFACTURING CO.,**  
88 E. Main St., Middletown, Conn.

PERSONNEL: G. M. Williams, Sr., Pres.; T. M. Russell, V. Pres.; C. J. Sherer, V. Pres. & Treas.; A. P. Smith, V. Pres., Secy. & Pers. Dir.; G. T. Palmer, Pur. Agt.; R. E. Dowd, Chief Engr.

**RUSSELL UNIFORM CO.,**

1600 Broadway, New York, N. Y.  
PERSONNEL: J. A. Russell, Pres., Secy. & Sales Mgr.; A. Russell, V. Pres. & Treas.; C. White, Gen. Mgr. & Pur. Dir.; P. Richmond, Prod. Mgr.

# ROEBLING

*means Control in the Air!*



**Cord and Terminal Assemblies**  
**Aircraft Terminals**  
**Cords and Strands**  
**Engineered Slings**

THE COMPLETE Roebling line has made this name a byword in the control shops of the entire industry.

Illustrated, various types of Roebling Cord and Strand, including 7x7, 19 wire strand, 7x19, and 6x7 with cotton center. Also a section of Lock-Clad control cord and several types of swaged terminals. Wide range of diameters, stainless or galvanized, pre-formed or non-pre-formed. Roebling Slings and Sling Fittings available in sizes and fitting types to meet your specifications.

*Aircord Division*

**JOHN A. ROEBLING'S SONS COMPANY**  
 TRENTON 2, NEW JERSEY

*Branches and Warehouses in Principal Cities*

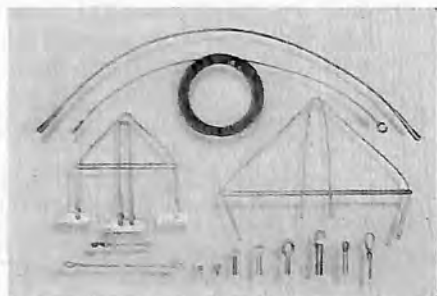



**RYAN AERONAUTICAL CO.,**

Lindbergh Field, San Diego 12, Calif.  
 PERSONNEL: T. C. Ryan, Pres., Treas. & Gen. Mgr.; E. D. Prudden, V. Pres.; E. Molloy, V. Pres.-Mfg.; G. C. Woodard, Secy.; G. E. Barton, Factory Mgr.; S. C. Breder, Sales Mgr.; O. F. Rigley, Pur. Dir.; W. F. Persons, Ind. Rel. Dir.; W. Wagner, Pub. Dir. & Adv. Mgr.; B. T. Salmon, Chief Engr.; J. C. Noakes, Controller.

**JOSEPH T. RYERSON & SON, INC.,**

2558 W. 16th St., Chicago, Ill.  
 PERSONNEL: E. D. Graff, Pres.; H. B. Ressler, V. Pres.; F. S. Doran, V. Pres. & Pur. Agt.; R. C. Ross, Secy.; K. J. Evans, Pub. Dir.

**S****S A E STEELS,**

1420 E. 47th St., Cleveland 3, O.  
 PERSONNEL: F. A. Michell, Gen. Mgr.; E. R. Salisbury, Sales Mgr.; W. S. Bidle, Jr., Pur. Dir.

**SKF INDUSTRIES, INC.,**

Front St. & Erie Ave., Philadelphia, Pa.  
 PERSONNEL: W. L. Batt, Pres.; S. F. Wollmar, Exec. V. Pres.; T. W. Dinlocker, Secy. & Treas.; R. H. DeMott, Gen. Sales Mgr.; H. J. Lance, Pur. Agt.; H. S. Langdon, Pers. Dir.; R. C. Byler, Pub. Dir.; G. Palmgren, Chief Engr.

**S & M Lamp Co.,**

119 W. 36th Pl., Los Angeles, Calif.  
 PERSONNEL: J. Shirreffs, Pres. & Gen. Mgr.; W. G. Shirreffs, V. Pres. & Chief Engr.; S. Friedman, Secy.; L. E. Daubenberger, Treas.; H. S. Gardner, Pur. Agt.

**SAFETEE GLASS CO.,**

Wayne Junction, Philadelphia, Pa.  
 PERSONNEL: R. A. Gibbs, Pres. & Gen. Mgr.; J. W. Gibbs, V. Pres., Pers. Dir. & Pub. Dir.; A. Boehm, Secy.; C. L. Krebs, Treas.; C. A. McCusker, Sales Mgr. & Pur. Agt.; A. G. Worrall, Chief Engr.

**ST. JOHN X-RAY SERVICE, INC.,**

30-20 Thomson Ave., Long Island City 1, N. Y.  
 PERSONNEL: H. R. Isenburger, Pres.; A. St. John, V. Pres.

**ST. LOUIS AIRCRAFT CORP.,**

8000 N. Broadway, St. Louis, Mo.  
 PERSONNEL: E. B. Meissner, Pres. & Gen. Mgr.; H. M. McKay, N. L. Rehnquist, V. Pres.; E. Augustine, Treas.; W. A. Fitzgerald, Pur. Agt.; L. S. Lutton, Chief Engr.

**ST. LOUIS RADIO ENGINEERING CO.,**

6974 Dartmouth Ave., St. Louis 5, Mo.  
 PERSONNEL: B. C. Payne, Gen. Mgr.

**ST. LOUIS SPRING CO.,**

6650 Eastern Ave., St. Louis, Mo.  
 PERSONNEL: H. P. Moog, Pres., Treas. & Gen. Mgr.; A. A. Apple, V. Pres. & Sales Mgr.; A. M. Goetz, Secy.; P. Percich, Pur. Agt.; F. Walters, Pers. Dir.; J. A. Maxwell, Pub. Dir.; H. Paine, Chief Engr.

**SAMSON UNITED CORP.,**

1700 University Ave., Rochester 10, N. Y.  
 PERSONNEL: D. D. Gillespie, Pres.; D. J. Burns, Jr., V. Pres.; J. Lubelle, Secy.; T. E. Krizanek, Treas.; N. Arnold, Prod. Mgr.; W. G. Church, Jr., Sales Mgr.; B. B. Goodman, Pur. Dir.; G. Everett, Pers. Dir.; C. R. Wright, Chief Engr.

**W. J. SAVAGE CO., Knoxville, Tenn.**

PERSONNEL: J. H. Murrian, Pres.; J. A. Murrian, V. Pres. & Gen. Mgr.; C. M. Rawlings, Asst. Secy. & Pur. Agt.; C. W. McConnell, Asst. Treas. & Pers. Dir.; W. W. Carson, Chief Engr.

**SAWYER BELT HOOK CO.,**

16 Warren Ave., Pawtucket, R. I.  
 PERSONNEL: J. D. Sawyer, Treas.; G. F. Minkins, Gen. Mgr.

**SAYLOR BEALL MFG. CO.,**

1501 E. Philadelphia Ave., Detroit, Mich.  
 PERSONNEL: R. V. Allman, Pres.; C. S. Fisher, V. Pres.; E. R. Saur, Pur. Agt.; E. J. Formhals, Chief Engr.

**SCHAUER MACHINE CO.,**

2060 Reading Rd., Cincinnati, O.  
 PERSONNEL: A. J. Kohn, Pres. & Gen. Mgr.; K. Wilson, Sales Mgr.; R. Wheelbarger, Pur. Agt.; L. Brewer, Pers. Dir.; R. E. Cleary, Pub. Dir.; G. L. Nord, Chief Engr.

**SCHLEGEL MFG. CO.,**

277 N. Goodman St., Rochester, N. Y.  
 PERSONNEL: C. P. Schlegel, Pres.; J. F. Sproat, Secy. & Sales Mgr.; G. C. Schlegel, Treas. & Pur. Agt.; C. F. Schlegel, Gen. Mgr.; T. G. White, Pub. Dir.; A. Rydquist, Chief Engr.

**SCHORI PROCESS CORP.,**

8-11 43rd Rd., Long Island City, N. Y.  
 PERSONNEL: H. L. Green, Pres. & Treas.; L. Harris, V. Pres. & Secy.; B. Goldberg, Chief Engr.

**A. SCHRADER'S SON, DIV. OF SCOVILL MANUFACTURING CO., INC., 470 Vanderbilt Ave., Brooklyn, N. Y.**

PERSONNEL: W. T. Hunter, V. Pres. & Gen. Mgr.; R. L. deBrauwere, Asst. Secy.; V. C. Greaves, Asst. Treas.; G. A. Drew, Sales Mgr.; C. Wilcox, Pur. Agt.; T. A. Browne, Pers. Dir.; D. S. Hunter, Pub. Dir.; S. T. Williams, Chief Engr.

**W. A. SCHUYLER,**

250 W. 57th St., New York 19, N. Y.  
 PERSONNEL: W. A. Schuyler, Gen. Mgr.

**THE SCHWARZENBACH HUBER CO.,**

498 Seventh Ave., New York, N. Y.  
 PERSONNEL: E. G. Glaesel, Pres.; A. Schwarzenbach, V. Pres.; G. W. Betts, Secy.; O. Froelicher, Treas.

**L. N. SCHWIEN ENGINEERING CO., 5736 W. Washington Blvd., Los Angeles, Calif.**

PERSONNEL: L. N. Schwiem, Pres.; H. E. Glendinning, Secy.; L. K. Schwiem, Treas.; R. M. Vandegrift, Gen. Mgr. & Pers. Dir.; O. R. Coblentz, Sales Mgr. & Pub. Dir.; R. D. Vandegrift, Pur. Agt.; D. W. McLennan, Chief Engr.

**SCIACKY BROS.,**

4915 W. 67th St., Chicago, Ill.  
 PERSONNEL: D. Sciacky, S. Sciacky, Maurice Sciacky, Mario Sciacky, Partners; R. L. Tetaz, Pur. Agt.; W. R. Bernardi, Sales Mgr.; J. W. Newhall, Adv. Mgr.; D. Sciacky, Chief Engr.

**SCIENTIFIC INSTRUMENT CO.,**

531-35 W. Larned St., Detroit, Mich.  
 PERSONNEL: R. H. Papendell, Pres.; H. L. Emhoff, V. Pres., Treas. & Gen. Mgr.; G. L. Field, Secy.; G. W. Emig, Sales Mgr.; W. G. Byrnl, Pur. Agt.; F. Justice, Pers. Dir.; F. Farrow, Chief Engr.

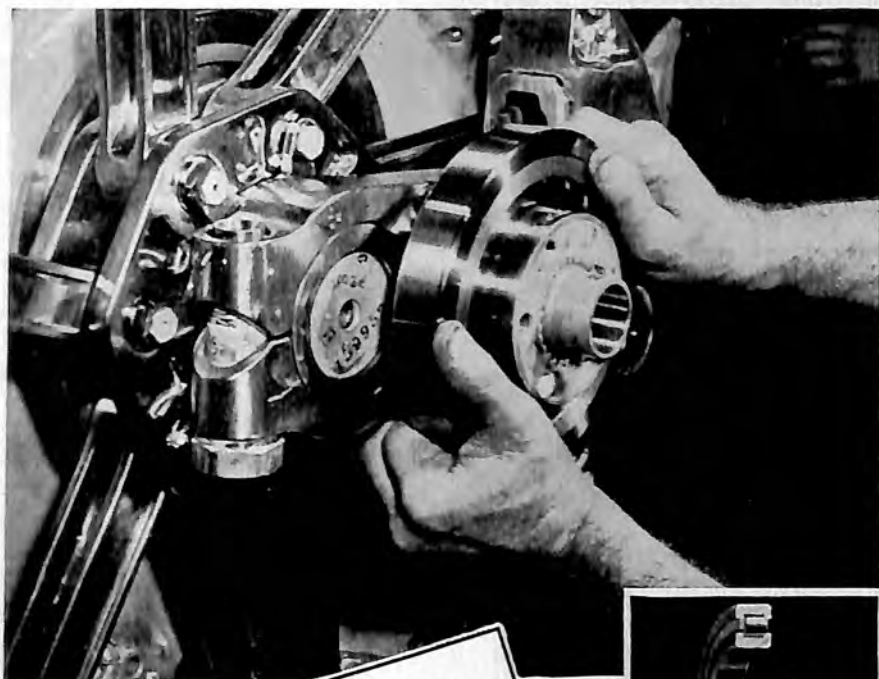

● **SKF** Cylindrical Roller Bearing on crankshaft of Wright Cyclone 14 Engine.

## Tolerances that predict Victory

The exacting tolerances of **SKF** Bearings frequently forecast the performance of the parts to which they are assigned. Ever since they pioneered on aircraft applications, **SKF's** have been synonymous with precision, smoothness, dependability and long life.

**SKF** INDUSTRIES, INC.,  
PHILA. 34, PA.

# SKF

Ball and Roller Bearings

**SCINTILLA MAGNETO DIV., BENDIX AVIATION CORP.,** Sidney, N. Y.

PERSONNEL: E. R. Breech, Pres.; G. E. Steiner, Div. Compt.; H. Hanni, Gen. Mgr.; T. Z. Fagan, Sales Mgr.; A. Bekker, Pur. Agt.; E. M. Van Name, Pers. Dir.; J. R. Frei, Chief Engr.

**SCOTT AVIATION CORP.,** Lancaster, N. Y.

PERSONNEL: E. M. Scott, Pres.; H. A. Benzel, V. Pres. & Chief Engr.; R. D. Pollock, V. Pres. & Treas.; E. C. Prior, Secy.; H. N. Crane, Prod. Mgr.; A. S. Brown, Sales Mgr.; E. J. Allein, Pur. Dir.; L. M. Crans, Pers. Dir.

**SCOVILL MANUFACTURING CO.,**

99 Mill St., Waterbury, Conn.

PERSONNEL: J. H. Goss, Pres. & Gen. Mgr.; L. P. Sperry, Exec. V. Pres. & Treas.; P. E. Fenton, V. Pres. & Sales Mgr.; F. T. Reeves, Secy.; A. P. Hickcox, Pur. Agt.; A. C. Curtiss, Pers. Dir.

**SCREW MACHINE PRODUCTS CO., INC.,**

1012 Eddy St., Providence 5, R. I.

PERSONNEL: G. Briggs, Pres. & Gen. Mgr.; S. E. Lummis, Treas.; D. O. Williams, Sales Mgr.; M. W. Seymour, Adv. Mgr.

**SEALED POWER CORP.,** Muskegon, Mich.

PERSONNEL: C. E. Johnson, Pres.; N. A. Moore, V. Pres. & Gen. Mgr.; R. R. Beardsley, Secy.; L. G. Matthews, Asst. Treas.; P. C. Johnson, Sales Mgr.; R. S. Harvey, Pur. Agt.; W. R. Tyson, Pers. Dir.; J. E. Norwood, Pub. Dir.; H. Olson, H. Ballard, Chief Engrs.

**SEAMAN PAPER CO.,**

222 W. Adams St., Chicago, Ill.

PERSONNEL: D. R. Seaman, Pres.; C. Seaman, V. Pres.; L. Springer, Secy.; A. J. Drusch, Treas., Gen. Mgr. & Sales Mgr.; A. J. Drusch, Jr., Prod. Mgr.

**SEAMLEX COMPANY, INC.,**

27-27 Jackson Ave., Long Island City 1, N. Y.

PERSONNEL: F. F. Jacobson, Pres. & Chief Engr.; A. E. Loeb, V. Pres. & Prod. Mgr.; A. M. Clair, Pur. Dir.

**SEARLE AERO INDUSTRIES, INC.,**

Orange, Calif.

PERSONNEL: M. O. Searle, Pres. & Chief Engr.; G. M. Marco, V. Pres.; V. A. Marco, Secy. & Sales Mgr.; M. Dittman, Treas.; F. Harrington, Gen. Mgr.; M. W. Kiphart, Pur. Agt.; D. L. Rahn, Pers. Dir.

**SEIBERLING RUBBER CO.,** Akron, O.

PERSONNEL: J. P. Seiberling, Pres.; C. W. Seiberling, V. Pres.; W. E. Palmer, Secy.; W. A. M. Vaughan, Treas.; J. L. Cochrun, Sales Mgr.; E. E. Neyland, Pur. Agt.; P. A. Bunnelle, Chief Engr.

**SEIDEN PNEUMATIC TOOL CO.,**

423 Barrett St., Jackson, Mich.

PERSONNEL: O. D. Lutes, Gen. Mgr.

**SEIDLITZ PAINT & VARNISH CO.,**

Kansas City, Mo.

PERSONNEL: C. N. Seidlitz, Pres. & Gen. Mgr.; L. J. Bohannon, V. Pres. & Sales Mgr.; W. P. Marsh, Secy.; W. E. Sunderland, Treas.; K. W. Ward, Pur. Agt.; H. Gershman, Pub. Dir.; O. Jensen, Chief Engr.

**SELECTAR MFG. CO.,**

21-10 49th Ave., Long Island City, N. Y.

PERSONNEL: F. Berhendt, Pres.; W. A. Johnson, Gen. Mgr.; B. J. Braker, Sales Mgr.

**SELLSTROM MANUFACTURING CO.,**

615 N. Aberdeen St., Chicago, Ill.

PERSONNEL: G. E. Sellstrom, Pres. & Gen. Mgr.; G. E. Wenstrom, Secy. & Treas.; C. E. Dennis, Sales Mgr. & Pub. Dir.; R. L. Calm, Pur. Agt.

**SENSENICH BROS.,** Lititz, Pa.

PERSONNEL: H. M. Sensesnich, M. M. Sensesnich, Partners; C. H. Brubaker, Prod. Mgr.; R. N. Bomberger, Sales Mgr. & Adv. Mgr.; M. S. Erb, Pur. Dir.; L. M. Witmer, Pers. Dir.; H. R. Uhrich, Chief Engr.

**THE SENTRY CO.,** Foxboro, Mass.

PERSONNEL: P. B. Crocker, Treas. & Gen. Mgr.; G. Wheeler, Sales Mgr.

**THE SERVICE RECORDER CO.,**

1375 Euclid Ave., Cleveland, O.

PERSONNEL: H. R. Cool, Pres., Treas. & Gen. Mgr.; E. L. Viets, V. Pres. & Sales Mgr.; K. A. Cool, Secy.

**SEWALL PAINT & VARNISH CO.,**

Kansas City, Mo.

PERSONNEL: E. R. Kyger, V. Pres. & Secy.; A. C. Bales, V. Pres.; R. E. Bernauer, Treas.; E. D. Liddy, Gen. Mgr.; G. W. Weissert, Sales Mgr.; W. LaBrant, Pur. Agt.; B. VanDel, Pub. Dir.

**SHAFER BEARING CORP.,**

35 E. Wacker Dr., Chicago, Ill.

PERSONNEL: R. P. Tennes, Pres. & Treas.; J. F. Ditzell, V. Pres. & Gen. Mgr.; A. H. Williams, V. Pres. & Chief Engr.; T. B. Lipson, Secy.; W. L. Kinnaw, Pur. Agt.; J. M. O'Dea, Pub. Dir.

**SHAKEPROOF INC.,**

2501 N. Keeler Ave., Chicago 39, Ill.

PERSONNEL: H. B. Smith, Pres. & Treas.; F. W. England, Exec. V. Pres.; C. L. Johnson, V. Pres. & Secy.; C. S. Schwartz, Prod. Mgr.; E. W. Fuller, Sales Mgr.; W. R. Smith, Pur. Dir.; J. Tomlin, Pers. Dir.; R. M. Wall, Adv. Mgr.; R. Wicks, Chief Engr.

**SHAKESPEARE PRODUCTS CO.,** 241 E.

Kalamazoo Ave., Kalamazoo, Mich.

PERSONNEL: H. G. Shakespeare, Pres. & Gen. Mgr.; D. E. Wallace, V. Pres.; M. Shakespeare, Secy.; W. J. Harrison, Treas.; M. Balch, Sales Mgr.; H. Barron, Pur. Agt.; E. Batterson, Chief Engr.

**SHALLCROSS MFG. CO.,**

10 Jackson Ave., Collingdale, Pa.

PERSONNEL: D. A. Shallcross, Gen. Mgr.; J. S. Shallcross, Sales Engr.; E. H. Miller, Pur. Agt.; F. D. Mitchell, Chief Engr.

**SHARON STEEL CORP.,** Sharon, Pa.

PERSONNEL: H. A. Roemer, Pres.; B. E. Kibbee, V. Pres. & Treas.; J. H. Morrison, D. B. Carson, G. A. Connors, V. Pres.; A. J. Watson, Secy.; W. S. Jackson, Gen. Mgr.; J. M. May, Prod. Mgr.; R. C. Garlick, Sales Mgr.; J. M. Hughes, Pur. Dir.; J. W. Swanson, Adv. Mgr.

**THE SHEFFIELD CORP.,**

721 Springfield St., Dayton 1, O.

PERSONNEL: L. F. Polk, Pres. & Gen. Mgr.; E. T. Noe, Secy.; O. M. Polk, Treas.; J. P. Bernard, Prod. Mgr.; R. H. Cannon, Pur. Dir.; W. Y. Conrad, Pers. Dir.; C. W. Hamilton, Pub. Dir.; W. I. Wilt, Adv. Mgr.; A. Wartiniger, Chief Engr.

**SHELL OIL CO., INC., AVIATION DEPT.,**

50 W. 50th St., New York, N. Y.

PERSONNEL: R. T. Goodwin, Mgr.; J. W. Freeman, J. L. Wheeler, Aviation Supervisors.

# THE SHEFFIELD VISUAL GAGE

*For*

**TOOL ROOM CHECKING  
CHECKING PRODUCTION GAGES  
PROCESS INSPECTION  
LABORATORY AND RESEARCH  
PRODUCTION INSPECTION  
CHECKING MASTER GAGES  
CHECKING PURCHASED PARTS  
ON ARRIVAL**

**MAGNIFICATIONS:  
10,000 5,000  
2,000 1,000  
AND  
500**



*Other*  
**SHEFFIELD  
PRECISION PRODUCTS**

- Internalgages
- Precision 5 inch Sine Bar
- Electrichek
- Multicheks
- Precisionaire
- Thread Checking Attachment for Visual Gages
- Air Gages
- Thread Lead Checking Instrument
- Universal External Measuring Instrument
- Universal Internal Measuring Instrument
- Checkmatic
- Nitrigages, Cylindrical and Taper Plugs and Rings
- Nitrigages, Thread Plugs and Rings, Straight and Taper
- Guidegage
- Nitrigages, Pipe Thread
- Indicator Plug Gage
- Indicator Snap Gages
- Double End Thread Ring Gage Holder
- Thread Measuring Wires
- Length Gages, Adjustable Limit
- Adjustable Limit Plug Gages
- Snap Gages, Adjustable Limit
- Spline and Serration Gages
- Special Gages
- Woodruff Keyway Gages
- Vibration Frequency Meter

**THE SHEFFIELD CORPORATION**

\*\*\*

*Dayton, Ohio* U.S.A.

\*\*\*

**H. B. SHERMAN MFG. CO.,**

Battle Creek, Mich.

PERSONNEL: D. P. Ordway, Pres.; E. D. Sperry, V. Pres. & Gen. Mgr.; G. Townsend, Secy. & Treas.; H. H. Isaac, Pur. Agt.; W. Barrett, Pub. Dir.; L. M. Stinchcomb, Engr.

**THE SHERWIN-WILLIAMS CO.,**

101 Prospect Ave., Cleveland 1, O.

PERSONNEL: A. W. Stuedel, Pres.; H. D. Whittlesey, V. Pres.; T. G. Murphy, Secy.; L. H. Schroeder, Treas.; C. M. Lemperly, Gen. Mgr.; N. E. Van Stone, Prod. Mgr.; F. E. Davis, Pur. Dir.; L. E. Ebeling, Pers. Dir.; C. F. Toll, Pub. Dir.; L. W. Dasbach, Adv. Mgr.

**SHULER AXLE CO., INC.,** Louisville, Ky.

PERSONNEL: J. P. Potter, Pres. & Gen. Mgr.; R. L. Bishop, V. Pres.; J. J. Hart, Secy. & Treas.; C. M. Erthle, Pur. Agt.; W. Anderson, Pub. Dir.; R. B. Liggatt, Chief Engr.

**SHURE BROTHERS,**

225 West Huron, Chicago, Ill.

PERSONNEL: S. N. Shure, Gen. Mgr.; M. A. Cope, Prod. Mgr.; J. A. Berman, Sales Mgr. & Adv. Mgr.; R. Clark, Pur. Dir.; R. Parowski, Pers. Dir.; A. C. Coleman, Pub. Dir.; B. Bauer, Chief Engr.

**SIGMA INSTRUMENTS, INC.,**

78 Freeport St., Boston, Mass.

PERSONNEL: S. B. Allen, Pres.; C. Bassett, Treas. & Pur. Agt.; H. N. Boyle, Jr., Gen. Mgr. & Sales Mgr.; R. T. Fisher, Chief Engr.

**SIMMONDS AEROCESSORIES, INC., 10**

Rockefeller Plaza, New York, N. Y.

Plants

Long Island City, N. Y.; Vergennes, Vt.; Glendale, Calif.

**THE SIMMONS MANUFACTURING CO.,**

Ashland, O.

PERSONNEL: S. A. Rogers, Pres.; J. D. Rogers, V. Pres. & Gen. Mgr.; J. H. Griswold, Secy.; H. Dennison, Treas.; H. D. McNamara, Pur. Dir.; J. W. Miller, Pers. Dir.; H. M. Reuss, Chief Engr.

**SIMONS PAINT SPRAYING EQUIPMENT**

CO., 17 Maryland Ave., Dayton, O.

PERSONNEL: G. W. Simons, Prop.

**SIMPLEX PRODUCTS CORP.,**

3830 Kelley Ave., Cleveland, O.

PERSONNEL: F. G. Ferguson, Pres., Secy. & Treas.; D. M. Solenberger, V. Pres.; H. T. Scoville, Sales Mgr.; D. Schappi, Pur. Agt.; R. C. Thompson, Chief Engr.

**SIMPLEX WIRE & CABLE CO.,**

79 Sidney St., Cambridge 39, Mass.

PERSONNEL: E. Morss, Pres.; G. L. Roberts, Sales Mgr.; E. N. Bowry, Pur. Dir.; A. F. Lewis, Adv. Mgr.

**SINCLAIR REFINING CO.,**

630 Fifth Ave., New York, N. Y.

PERSONNEL: E. W. Sinclair, Pres.; J. W. Carnes, V. Pres.; M. L. Gosney, V. Pres. & Treas.; O. M. Gerstung, Secy.; L. P. Lochridge, Mgr.-Domestic Lubricating Sales; D. S. Bixler, Asst. Mgr.-Aviation Sales; C. M. Larson, Chief Consulting Engr.; C. W. McAllister, Aeronautical Engr.

**SKILSAW, INC.,**

5033 Elston Ave., Chicago 30, Ill.

PERSONNEL: B. J. Sullivan, Pres. & Gen. Mgr.; E. W. Ristav, V. Pres. & Adv. Mgr.; E. J. Kelley, Secy.; E. B. McConville, Treas.; J. J. Topolinski, Prod. Mgr.; M. F. Huseby, Sales Mgr.; W. Ruppert, Pur. Dir.; W. Grafe, Pers. Dir.; F. Koenig, Chief Engr.

**SKYDYNE, INC.,**

River Rd., Port Jervis, N. Y.

PERSONNEL: M. K. Weill, Pres.; R. L. Weill, V. Pres. & Secy.

**SKYLARK MANUFACTURING CO., INC.,**

350 Washington Blvd., Venice, Calif.

PERSONNEL: F. G. Perkins, Pres.; E. A. Perkins, V. Pres.; V. R. G. Wilbur, Secy. & Treas.; F. H. Perkins, Pur. Agt.

**A. O. SMITH CORP.,**

3533 N. 27th St., Milwaukee, Wisc.

PERSONNEL: W. C. Heath, Pres.; R. F. Bell, J. M. Floyd, V. Pres.; J. J. Stamm, Secy. & Treas.; W. Froderman, Pur. Agt.; L. J. Parrish, Pers. Dir.; D. W. Sherman, Chief Engr.

**D. B. SMITH & CO.,**

414 Main St., Utica, N. Y.

PERSONNEL: M. H. Smith, Pres.; T. M. Burton, V. Pres.; G. R. Smith, Jr., Secy.; A. P. Smith, Treas.

**F. A. SMITH MANUFACTURING CO., INC.,**

Rochester 2, N. Y.

PERSONNEL: H. P. Toppin, Pres.; H. M. Sylvester, Secy. & Treas.; H. A. Ketchum, Gen. Mgr.; C. B. Mahan, Prod. Mgr.; D. R. Schroedel, Sales Mgr.; G. J. Andres, Pur. Dir.; F. J. O'Grady, Pers. Dir.; W. T. Jensen, Pub. Dir. & Adv. Mgr.; E. I. Rusk, Chief Engr.

**J. EARL SMITH,**

2821 Live Oak St., Dallas, Tex.

PERSONNEL: J. E. Smith, Pres., Gen. Mgr. & Chief Engr.; Mrs. J. E. Smith, V. Pres.; M. C. Raithel, Secy.

**SMITH TOOL & ENGINEERING CO.,**

900 N. Sandusky Ave., Bucyrus, O.

PERSONNEL: S. H. Smith, Pres. & Treas.; J. A. Davis, Secy.; J. W. Overholt, Prod. Mgr.; K. C. Jenney, Sales Mgr. & Adv. Mgr.; C. F. Zincke, Pur. Dir.; S. K. Kalber, Chief Engr.

**SMITH WELDING EQUIPMENT CORP.,**

2633 Fourth St., S. E., Minneapolis, Minn.

PERSONNEL: E. H. Smith, Pres.; J. E. Smith, V. Pres. & Prod. Mgr.; L. L. McBurney, Secy. & Gen. Mgr.; N. L. Andrus, Asst. Sales Mgr.; E. B. Johnson, Pur. Dir.; E. T. Gadois, Pers. Dir.; N. N. Canfield, Adv. Mgr.; L. J. Ganyaw, Chief Engr.

**SNAP-ON TOOLS CORP.,**

Kenosha, Wisc.

PERSONNEL: J. Johnson, Pres.; R. Palmer, V. Pres. & Sales Mgr.; W. A. Seidemann, Secy. & Prod. Mgr.; W. C. Nemitz, Treas.; F. A. Tetzlaff, Pur. Dir.; C. Holderness, Pers. Dir.; W. F. Holz, Pub. Dir.; G. A. Smith, Adv. Mgr.; G. Walraven, Chief Engr.

**SNAPVENT CO.,**

521 W. Cumberland Ave., Knoxville 1, Tenn.

PERSONNEL: B. B. Simcox, Pres.; M. P. Simcox, Treas.

**SNOW REMOVAL EQUIPMENT CO.,**

400 Seventh St., San Francisco, Calif.

PERSONNEL: N. K. Davis, Pres.; A. E. Mason, V. Pres., Gen. Mgr. & Sales Mgr.; J. M. Azevedo, Secy., Treas. & Pur. Agt.; H. Pruss, Pub. Dir.

**M. L. SNYDER & SON,**

Jasper &amp; York Sts., Philadelphia, Pa.

PERSONNEL: H. A. Greene, Pres.; C. Synder, Treas.; F. M. Greene, Sales Mgr.; H. M. Simpson, Pur. Agt.; O. P. Montgomery, Pub. Dir.



**“WHEN GIRDING FOR GOLIATHS . . .”**



. . . it is often the items of slingshot proportions that count. And in fighter planes or bombers it is the little parts that make the larger ones important. This is especially true of junction box assemblies, the metal compartments that hold the nerve-ends of the plane, myriad wires that control its every reflex. Unionair junction box assemblies and other related equipment have built into them much more than the specifications require. This plus—in craftsmanship and engineering—has earned us the unique position we enjoy today in the aircraft industry.

**UNIONAIR**

*Junction Box Assemblies — Hydraulic Fittings  
Conduit Fittings — Junction Boxes*

UNION AIRCRAFT PRODUCTS CORP., NEW YORK



**SOCONY-VACUUM OIL CO., INC.,**

26 Broadway, New York 4, N. Y.  
 PERSONNEL: J. A. Brown, Pres.; F. E. Powell, Jr., Gen. Mgr.-Marine & Aviation Sales Dept.; W. L. Baker, Dom. Mgr.; P. V. Keyser, Research (Aviation); A. E. Smith, Aviation Engr. (Eastern); B. H. Henderson, Aviation Engr. (Central Western).

**SOLAR AIRCRAFT CO.,**

1212 W. Juniper St., San Diego 12, Calif.  
 PERSONNEL: E. T. Price, Pres. & Gen. Mgr.; R. E. Craig, V. Pres. & Prod. Mgr.; J. I. Oatman, Secy.; A. W. Briggs, Treas.; P. S. Seitz, Sales Mgr.; G. H. Bateman, Pur. Dir.; E. E. Binger, Pers. Dir.; V. Wyatt, Pub. Dir. & Adv. Mgr.; W. C. Heath, Chief Engr.

**SOSS MANUFACTURING CO.,**

21777 Hoover Rd., Detroit, Mich.  
 PERSONNEL: C. J. Soss, Pres.; S. Soss, V. Pres., Secy., & Sales Mgr.; H. Soss, Treas.; S. R. Synder, Pur. Agt.; W. Hamilton, Pers. Dir.; A. TenEyck, Pub. Dir.; F. Wambold, Chief Engr.

**THE SOUND SCRIBER CORP.,**

82 Audubon St., New Haven, Conn.  
 PERSONNEL: L. Thompson, Pres.; H. Gfroerer, V. Pres., Treas. & Gen. Mgr.; H. K. Greer, Secy.; O. M. Ober, Pur. Agt.; R. L. Stone, Chief Engr.

**SOUTH BEND LATHE WORKS,**

South Bend, Ind.

**SOUTH SHORE MACHINE & TOOL WORKS, INC.,**

Merrick Rd., Seaford, N. Y.  
 PERSONNEL: G. A. Bauer, Pres.; A. G. Bauer, V. Pres.; J. A. Sullivan, Secy. & Treas.

**SOUTHERN AIRCRAFT CORP.,**

Garland, Tex.  
 PERSONNEL: J. R. McClain, Ch. of Board; W. C. Brown, Pres.; A. E. Pattison, V. Pres. & Treas.; F. H. Brown, Secy.

**SOUTHERN CALIFORNIA AIRPARTS, DIV. OF JARVIS MANUFACTURING CO.,**

924 Thompson Ave., Glendale, Calif.  
 PERSONNEL: S. M. Jarvis, Pres. & Gen. Mgr.; B. C. Jarvis, V. Pres.; L. W. Martin, Secy. & Treas.; F. I. Palmer, Compt.; E. H. Fetschke, Prod. Mgr.; D. S. Bentley, Sales Mgr.; C. A. Hasenstab, Pur. Dir.; W. K. Whitney, Pers. Dir.

**SOUTHERN ENGINEERING CO., INC.,**

816 W. Fifth St., Los Angeles, Calif.  
 PERSONNEL: H. R. Peacock, Pres.; C. Coe, V. Pres. & Gen. Mgr.; D. B. Coe, Secy.

**SPARKS WITHINGTON CO.,**

North St., Jackson, Mich.  
 PERSONNEL: W. Sparks, Pres.; W. J. Corbett, V. Pres.; D. Johnson, Secy.; H. Johnston, Treas.; R. W. Clark, Gen. Mgr.; E. T. H. Hutchinson, Sales Mgr.; J. Towler, Pur. Agt.

**SPARTAN AIRCRAFT CO.,**

1900 N. Sheridan Rd., Tulsa, Okla.  
 PERSONNEL: J. P. Getty, Pres.; M. W. Balfour, V. Pres.; F. T. Hopp, Secy. & Treas.; G. F. Shortess, Contract Officer; J. Bredouw, Pur. Agt.; W. H. Woodward, Pers. Dir.; F. Stewart, Chief Engr.

**SPAULDING FIBRE CO., INC.,**

310 Wheeler St., Tonawanda, N. Y.  
 PERSONNEL: C. C. Steck, Pres. & Gen. Mgr.; H. W. Grieser, V. Pres. & Prod. Mgr.; C. M. Pike, Secy.; S. E. Clow, Treas.; A. P. Hardleben, Pur. Dir.; R. B. Green, Adv. Mgr.

**SPECIAL MACHINE TOOL ENGINEERING WORKS,**

254 Canal St., New York 13, N. Y.  
 PERSONNEL: V. Silber, Pres. & Gen. Mgr.; W. Silber, V. Pres.; D. Blatt, Prod. Mgr.; A. H. Cook, Pur. Dir.; H. G. Glugatch, Pers. Dir.; D. E. Alton, Chief Engr.

**SPEED WAY MFG. CO.,**

1834 S. 52nd Ave., Cicero, Ill.  
 PERSONNEL: G. L. Newcome, Pres.; M. Chapek, Treas. & Gen. Mgr.; F. W. Anderson, Sales Mgr.; D. A. Baker, Pur. Agt.; R. S. McKeage, Chief Engr.

**SPENCER THERMOSTAT CO.,**

34 Forest St., Attleboro, Mass.  
 PERSONNEL: R. Willard, Pres.; V. D. Davignon, V. Pres.; C. J. Stone, Secy. & Treas.; V. G. Vaughan, Gen. Mgr.; E. F. Kurtz, Sales Mgr.; J. D. Bolesky, Chief Engr.

**SPERRY GYROSCOPE CO., INC.,**

Manhattan Bridge Plaza, Brooklyn, N. Y.  
 PERSONNEL: R. E. Gillmor, Pres. & Gen. Mgr.; R. B. Lea, V. Pres.-Sales; P. R. Bassett, V. Pres.-Engrg.; L. F. Malkovsky, V. Pres.-Mfg.; J. Sanderson, V. Pres.-Finance; J. B. Wilson, Secy.; F. W. Kilduff, Treas.; H. H. Willis, Gen. Sales Mgr.; J. J. Wilson, Pur. Dir.; H. L. Grosvenor, Gen. Pers. Dir.; J. H. Fountain, Pub. Dir.; J. A. Fitz, Adv. Dir.; E. C. Sparling, Chief Engr.

**SPERRY PRODUCTS, INC.,**

1505 Willow Ave., Hoboken, N. J.  
 PERSONNEL: J. B. Farwell, Pres. & Gen. Mgr.; E. G. Sperry, V. Pres., & Treas.; J. H. Lipschutz, Secy.; M. F. Sproul, Sales Mgr.; L. C. Wohlberg, Pur. Agt.; E. P. Dodge, Pers. Dir.; P. E. Moreton, Pub. Dir.; E. A. Crawford, Chief Engr.

**THE SPOOL COTTON CO., CROWN FASTENER DIV.,**

745 Fifth Ave., New York, N. Y.  
 PERSONNEL: H. Grandage, V. Pres.; J. S. Campbell, Sales Mgr.; C. H. Neuer, Pur. Dir.; D. F. Sullivan, Adv. Mgr.

**SPRAY ENGINEERING CO.,**

114 Central St., Somerville, Mass.  
 PERSONNEL: W. B. Thompson, Pres. & Treas.; F. G. Dennison, V. Pres. & Chief Engr.; A. S. True, Sales Mgr.; A. L. MacLachlan, Pur. Agt.

**SPRIESCH TOOL & MFG. CO., INC.,**

10 Howard St., Buffalo, N. Y.  
 PERSONNEL: J. Cheney, Pres. & Treas.; J. Spriesch, V. Pres.; W. Cheney, Secy.

**SPRUCE LUMBER & VENEER CO.,**

Vancouver, Wash.  
 PERSONNEL: H. H. McLaughlin, G. K. Voss, Partners.

**SQUARE D CO.,**

6060 Rivard St., Detroit, Mich.  
 PERSONNEL: F. W. Magin, Pres.; L. W. Mercer, V. Pres.; H. Morgan, Secy. & Treas.; C. L. Hull, Sales Mgr.; K. L. Winslow, Pur. Agt.; E. W. Fry, Pers. Dir.; J. H. Venum, Pub. Dir.; J. L. Jackson, Chief Engr.

**STALEY MANUFACTURING CORP.,**

14th & Union Sts., Columbus, Ind.  
 PERSONNEL: J. H. Staley, Pres.

**STANDARD AIRCRAFT PRODUCTS, INC.,**

121 Franklin St., Dayton 2, O.  
 PERSONNEL: R. N. Webster, Pres.; J. Golob, V. Pres. & Chief Engr.; L. G. Zarbock, V. Pres. & Sales Mgr.; A. H. Ellinger, Secy. & Treas.; R. Casey, Gen. Mgr.; F. Abercrombie, Prod. Mgr.; W. Ruetz, Pur. Dir.; D. E. Stauffer, Pers. Dir.; V. Sheffield, Pub. Dir.; V. L. Hansen, Adv. Mgr.



### Bill's *Idea* Is In The Fight Too!

Bill has only been in the army a short time, but he's been in the war a lot longer! Now, he's pitching shells at the enemy, but overhead is the air-cover of American planes he helped assure.

The reason Bill liked working at Solar and is looking forward to his peacetime job is because—as he says,

"the outfit really *makes* things!" He feels that the future is bright where a fellow has an opportunity to do more than just assemble parts...where thought and skill put an indelible stamp of quality on a product.



**SOLAR AIRCRAFT COMPANY • SAN DIEGO 12, CALIFORNIA**

**STANDARD CONVEYOR CO.,**

N. St. Paul 9, Minn.

PERSONNEL: H. L. Donahower, Pres. & Treas.; C. M. Bend, V. Pres.; A. M. Giefer, Secy.; E. E. Boberg, Gen. Sales Mgr.; D. A. Chandler, Sales Mgr.; H. Keech, Pur. Dir.; I. M. Carlson, Adv. Mgr.; C. M. Bodin, Chief Engr.

**STANDARD ELECTRIC CO., INC.,**

Route 3, Box 121-B, San Antonio, Tex.

PERSONNEL: B. Dubinski, Pres.; L. Dubinski, Secy. & Treas.; A. Lamm, Prod. Mgr.; E. E. Eckert, Sales Mgr.

**THE STANDARD ELEC. TIME CO.,**

Springfield, Mass.

PERSONNEL: F. A. Riggs, Pres.; C. M. Whiteford, V. Pres.; H. W. Angier, Secy.; C. B. Fitts, Treas. & Gen. Mgr.; H. P. Blake, Sales Mgr.; L. P. Marshall, Pur. Agt.; Pers. Dir. & Chief Engr.; C. F. Barrett, Pub. Dir.

**THE STANDARD ELECTRICAL TOOL CO.,**

2488 River Rd., Cincinnati, O.

PERSONNEL: W. A. Ferguson, Pres. & Treas.; L. A. Hauck, V. Pres. & Chief Engr.; R. A. Huhn, Secy. & Sales Mgr.; J. J. Klopp, Pur. Agt.

**STANDARD FELT CO., DIV. OF HUNTINGTON LAND AND IMPROVEMENT CO.,**

29-115 S. Palm Ave., Alhambra, Calif.

PERSONNEL: H. S. Cook, V. Pres. & Gen. Mgr.; J. S. Roome, Pur. Agt.; C. M. O'Donnell, Pers. Dir.; J. S. Murray, Chief Engr.

**STANDARD MACHINERY CO.,**

351 Indiana Ave., N. W., Grand Rapids 4, Mich.

PERSONNEL: J. Monahan, Pres. & Gen. Mgr.

**STANDARD OIL CO. OF CALIFORNIA,**

225 Bush St., San Francisco 20, Calif.

PERSONNEL: H. D. Collier, Pres.; R. C. Stoner, J. L. Hanna, J. H. MacGaregill, F. S. Bryant, R. G. Pollis, T. S. Peterson, E. J. McClanahan, G. J. O'Brien, R. K. Davies, V. Pres.; B. W. Letcher, Secy. & Compt.; H. C. Judd, Treas.; H. R. Cuyler, Gen. Sales Mgr.; J. E. Black, Foreign Trade Dept. Mgr.; L. B. Waters, Pur. & Stores Dept. Mgr.; R. F. Bradley, Aviation Sales Mgr.; L. W. Aubry, Asst. Aviation Sales Mgr.

**STANDARD OIL CO., OF KENTUCKY,**

426 Bloom St., Louisville, Ky.

PERSONNEL: W. E. Smith, Pres.; W. G. Violette, V. Pres.; D. F. Cocks, Secy.

**STANDARD OIL CO. OF NEW JERSEY,**

26 Broadway, New York, N. Y.

PERSONNEL: R. C. Oertel, Sales Mgr., Aviation Dept.

**STANLEY ELECTRIC TOOL DIV.,**

New Britain, Conn.

PERSONNEL: L. M. Knouse, Gen. Mgr.; C. Powers, Prod. Mgr.; H. W. Blackman, Sales Mgr.; D. E. Buckwell, Pub. Dir.; G. M. Fletcher, Adv. Mgr.

**STAR PATTERN WORKS,**

1248 Ray St., Dayton, O.

PERSONNEL: C. L. Templeton, Gen. Mgr.

**THE L. S. STARRETT CO.,**

Athol, Mass.

PERSONNEL: D. Findlay, Pres.; A. H. Starrett, V. Pres.; W. G. Nims, Treas.; W. J. Greene, Sales Mgr.; E. E. Warner, Pur. Agt.; J. Hunton, Pers. Dir.; H. E. Masters, Pub. Dir.; A. E. Williams, Chief Engr.

**THE STATES CO.,**

19 New Park Ave., Hartford 6, Conn.

PERSONNEL: E. C. Alden, Pres.; H. N. Porter, Secy., Sales Mgr. & Adv. Mgr.; H. P. Blakeslee, Treas.; C. Fitchner, Pur. Dir.; H. J. Liebe, Engr.

**STAYNEW FILTER CORP.,**

11 Centre Park, Rochester, N. Y.

PERSONNEL: L. L. Dollinger, Pres. & Gen. Mgr.; F. J. Willson, V. Pres.; I. H. Bauman, Secy.; N. A. Hamill, Treas.; J. S. Zahniser, Sales Mgr.; L. J. Holden, Pur. Agt.; C. F. Hasselwander, Chief Engr.

**STEEL FORMING CORP.,**

1619 S. Alameda St., Los Angeles, Calif.

PERSONNEL: I. T. Sepin, Pres.; J. A. Stone, V. Pres.; K. E. Drebert, Secy.; N. K. Myers, Pur. Agt.

**THE STEEL PRODUCTS ENGINEERING**

CO., 1205 W. Columbia St., Springfield, O.

PERSONNEL: J. E. McAdams, Pres.; S. L. Tatum, V. Pres.; W. C. Jordan, V. Pres. & Gen. Mgr.; I. W. Clark, Secy.; D. Applegate, Pur. Agt.; A. W. Endter, Pers. Dir.; E. F. Fowle, Chief Engr.

**STEEL AND TUBES DIV., REPUBLIC**

STEEL CORP., 224 E. 131st St., Cleveland 8, O.

PERSONNEL: J. V. Burley, Gen. Mgr.-Sales; C. H. Reinert, Gen. Mgr.-Operations; J. A. Ireland, Asst. Gen. Mgr.-Sales; J. F. Keeler, Adv. Mgr.; E. B. Kelly, Special Aircraft Representative.

**STERLING ELECTRIC MOTORS, INC.,**

5401 Telegraph Rd., Los Angeles, Calif.

PERSONNEL: C. E. Johnson, Pres.; E. Mendenhall, V. Pres, Secy. & Gen. Mgr.; A. Adams, Treas.; W. D. Fabling, Sales Mgr.; R. McCormack, Pur. Agt.; M. Frink, Pers. Dir.; B. Palm, G. Whitman, Engrs.

**STERLING TOOL PRODUCTS CO.,**

363 E. Ohio St., Chicago, Ill.

PERSONNEL: S. A. Crosby, Pres. & Gen. Mgr.; B. M. Wood, Secy.; W. B. Muse, Sales Mgr. & Pub. Dir.; C. A. Hamilton, Pur. Agt.

**FREDERIC B. STEVENS, INC.,**

Detroit, Mich.

PERSONNEL: W. J. Cluff, Pres. & Gen. Mgr.; J. M. Mayers, V. Pres.; L. W. Montgomery, Secy. & Treas.; A. D. Hummel, Pur. Dir. F. Roberts, Adv. Mgr.

**M. C. STEWART, Ashburnham, Mass.**

PERSONNEL: M. C. Stewart, Pres. &amp; Treas.

**STEWART-WARNER CORP.,**

1826 Diversey Pkwy., Chicago, Ill.

PERSONNEL: J. S. Knowlson, Pres.; F. A. Ross, V. Pres.; L. Williams, Jr., V. Pres. & Secy.; F. A. Hiter, V. Pres. & Sales Mgr.; F. Kirch, Treas.; R. F. Stiles, Pur. Agt.; E. H. Dunning, Pers. Dir.; C. W. Grange, Pub. Dir.; A. W. LeFevre, Chief Engr.

**HERMAN H. STICHT CO., INC.,**

27 Park Place, New York 7, N. Y.

PERSONNEL: M. F. Sticht, Pres.; H. Sticht, V. Pres.; D. H. Sticht, Secy.; A. H. Volker, Treas., Gen. Mgr., Sales Mgr., Pur. Dir., Pers. Dir. & Adv. Mgr.

**EDWIN B. STIMPSON CO., INC.,**

70 Franklin Ave., Brooklyn 5, N. Y.

PERSONNEL: H. Banner, Adv. Mgr.

Choose your own opening  
with Crown Zippers

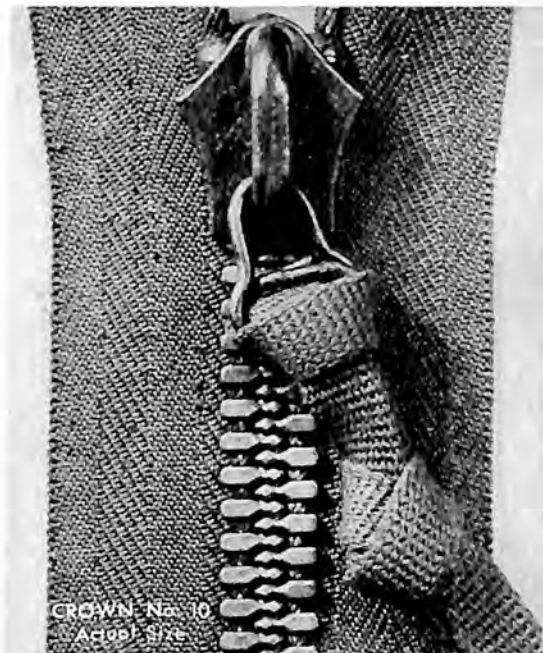

CROWN No. 10  
Actual Size

**NEW!**

Double-acting feature allows multiple slider assemblies (*some military jobs developed by Crown have as high as 10 sliders to a single track*)—enables you to choose your opening at any given point along zipper track.

Crown No. 10 Junbo Zippers for better engine covers, now used on leading types of military planes — use Crown No. 7 for Gunner's Windbreaks, Boots for Tail Wheels, Torque Tubes and Central Columns, Flying Boots.

The Services of Crown's Engineering Division are at your command to assist in installation or design problems.

SEND FOR SAMPLES



Test Crown's easy, smooth action  
Write or wire: The Spool Cotton Company  
Crown Fastener Division  
745 Fifth Avenue, New York 22, N. Y.

Use **CROWN ZIPPERS**  
FOR ALL AVIATION NEEDS

**STODDART AIRCRAFT RADIO CO.,**  
6630 Santa Monica Blvd., Hollywood 38,  
Calif.

PERSONNEL: R. R. Stoddart, Pres.; S. Timbrell, Treas.; W. H. Chester, Prod. Mgr.; P. J. Holmes, Chief Engr.

**STOKERUNIT CORP.,** 4548 W. Mitchell St.,  
Milwaukee 14, Wisc.

PERSONNEL: L. J. Radermacher, Pres.; P. O. Wernicke, V. Pres. & Chief Engr.; L. Petik, Prod. Mgr.; E. P. Wenke, Pur. Dir.

**STONE PROPELLER CO.,**  
701 E. Gilbert, Wichita, Kans.

PERSONNEL: M. J. Stone, A. M. Stone, Partners; A. M. Stone, Treas.; I. Hayden, Gen. Mgr.; W. Stoessel, Pers. Dir.

**STORMS DROP FORGING CO.,**  
70 Storms Court, Springfield, Mass.

PERSONNEL: R. A. Charpentier, Pres., Treas. & Gen. Mgr.; R. E. Whittle, V. Pres.; R. J. McKenna, Sales Mgr.

**THE STRIPPIT CORP.,**  
345 Payne Ave., N. Tonawanda, N. Y.

PERSONNEL: G. F. Wales, Pres.

**D. A. STUART OIL CO., LIMITED,**  
2727 S. Troy St., Chicago, Ill.

PERSONNEL: W. H. Oldacre, Pres.; F. J. Schmitt, Sales Mgr.; L. B. Perkins, Pur. Dir.; J. I. Carr, Adv. Mgr.; W. M. Duncan, Chief Engr.

**B. F. STURTEVANT CO.,**  
Damon St., Hyde Park, Boston, Mass.

PERSONNEL: E. B. Freeman, Pres. & Gen. Mgr.; G. C. Derry, H. F. Hagen, H. R. Sewell, N. Foss, E. B. Williams, Vice Pres.; J. H. Melzard, Secy.; B. S. Foss, Treas.; J. C. Thompson, Sales Mgr.; H. D. Orrok, Pur. Agt.; R. W. Chaplin, Pers. Dir.; E. W. Andros, Pub. Dir.; M. S. Leonard, Chief Engr.

**P. A. STURTEVANT CO.,** Addison, Ill.  
PERSONNEL: P. A. Sturtevant, Pres.; H. C. Hahn, V. Pres.; A. R. Sturtevant, Secy.; H. Nusperle, Asst. Gen. Mgr.; H. G. Rudd, Sales Mgr.; R. Stone, Pur. Agt.

**SUCCESS PLASTICS RECOVERY WORKS,**  
307 N. Pennsylvania St., Indianapolis 4,  
Ind.

PERSONNEL: I. C. Strohm, Pres.; L. R. Sereinsky, Gen. Mgr.; I. R. Davis, Pur. Dir.

**SUMMERILL TUBING CO.,**  
W. Fourth St., Bridgeport, Pa.

PERSONNEL: E. L. Parker, Pres.; R. R. Lawson, Exec. V. Pres.; G. E. Parker, V. Pres.-Sales; G. P. Kraemer, Secy. & Treas.; J. P. Dods, Dir. of Research & Adv. Dir.; W. A. Slater, Compt.; T. Heske, Plant Mgr.; C. W. Johnson, Pur. Agt.; A. J. Williamson, Chief Metallurgist; S. E. Kelso, Supt.; D. Frank, Dir. Pers.; P. V. Fly, Prod. Mgr.; B. C. Reiter, Plant Engr.

**SUN OIL CO.,**  
1608 Walnut St., Philadelphia, Pa.

PERSONNEL: J. H. Pew, Pres.; J. N. Pew, Jr., A. E. Pew, Jr., V. Pres.; S. B. Eckert, V. Pres. & Sales Mgr.; F. Cross, Secy. & Treas.; H. Thomas, Pur. Agt.; F. S. Cannan, Pub. Dir.

**SUNDSTRAND MACHINE TOOL CO.,**  
2531 11th St., Rockford, Ill.

PERSONNEL: H. L. Olson, Pres. & Gen. Mgr.; A. E. Johnson, V. Pres.; G. A. Lindblade, Secy. & Treas.; T. B. Buell, Sales Mgr.; A. E. Nelson, Pur. Agt.; B. Granberg, Chief Engr.

**SUNNEN PRODUCTS CO.,**  
7900 Manchester, St. Louis, Mo.

PERSONNEL: J. Sunnen, Pres.; W. A. Douglass, V. Pres., Gen. Mgr. & Sales Mgr.; R. S. Nichols, Secy. & Pur. Agt.; C. J. Schuepbach, Treas.; D. H. Nicholson, Pers. Dir. & Pub. Dir.; M. Langford, Chief Engr.

**SUPERIOR TUBE CO.,** Norristown, Pa.  
PERSONNEL: C. A. Warden, Pres.; S. L. Gabel, Gen. Mgr.; C. A. Warden, Jr., Exec. V. Pres. & Secy.; R. H. Gabel, V. Pres.-Engr.; P. E. Kelly, Treas. & Asst. Secy.; C. E. Pugh, Asst. Treas.; H. B. Brown, Jr., Sales Mgr.; J. J. Bowe, Asst. Gen. Mgr.; C. W. Buler, Plant Supt.; J. J. Buckley, Dir. of Pur.; W. J. McFarland, Pers. Dir.

**SURFACE COMBUSTION CORP.,**  
2375 Dorr St., Toledo 1, O.

PERSONNEL: F. H. Adams, V. Pres. & Gen. Mgr.; C. B. Phillips, V. Pres.-Sales; E. H. Taylor, Secy. & Treas.; M. Goodman, Pur. Dir.; W. J. Grover, Pub. Dir. & Adv. Mgr.; W. H. Hepburn, Chief Engr.

**SUTORBIT CORP.,**  
2008 E. Slauson Ave., Los Angeles 11,  
Calif.

PERSONNEL: W. F. Sutor, Pres. & Adv. Mgr.; R. S. Clark, V. Pres.; M. Collenge, Secy. & Treas.; G. W. Leeming, Pur. Dir.; R. Sharon, Chief Engr.

**SWIFT LUBRICATOR CO.,** Elmira, N. Y.  
PERSONNEL: C. T. Burke, Gen. Mgr.; C. W. Swift, Jr., Sales Mgr. & Pur. Agt.; E. Stachel, Pers. Dir.

**SWITLIK PARACHUTE CO.,**  
Lalor & Hancock Sts., Trenton 7, N. J.  
PERSONNEL: S. Switlik, W. Switlik, R. Switlik, L. Switlik, Partners; E. F. Connelly, Pub. Dir. & Adv. Dir.

**SYNTHANE CORP.,** Oaks, Pa.  
PERSONNEL: R. R. Titus, Pres.; J. B. Rittenhouse, V. Pres.; R. E. Heaton, Secy.; S. M. Fox, Pur. Agt.

---

## T

---

**THE TAFT PEIRCE MFG. CO.,**  
Woonsocket, R. I.

PERSONNEL: F. S. Blackall, Pres., Treas. & Gen. Mgr.; J. W. Wheeler, V. Pres.; W. A. Gordon, Secy.; P. V. Miller, Prod. Mgr.; W. E. Rogers, Sales Mgr. & Adv. Mgr.; A. M. Robinson, Pur. Dir.; J. Mason, Pers. Dir.; N. E. Brown, Chief Engr.

**C. J. TAGLIABUE MANUFACTURING CO.,**  
550 Park Ave., Brooklyn 5, N. Y.

PERSONNEL: A. E. Rowse, Prod. Mgr.; J. H. Nichols, Pur. Dir.; G. A. Terhune, Adv. Mgr.

**THE TANNEWITZ WORKS,** 301-325 Front  
Ave., N. W., Grand Rapids, Mich.  
PERSONNEL: E. C. Tannewitz, Pres.; L. Erhardt, Secy.; O. De Groot, Asst. Mgr.

V-TYPE (VAPORIZING). 15,000 B.t.u. Output. (Shown with fan). Also available in 50,000 B.t.u. Output Capacity. Both sizes supplied with or without fan.

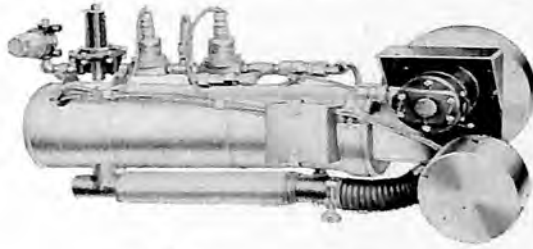

S-TYPE (SPRAY). 100,000 B.t.u. Output. Also available in 50,000 and 125,000 B.t.u. Output Capacities. All sizes can be operated on ram air or with fan.

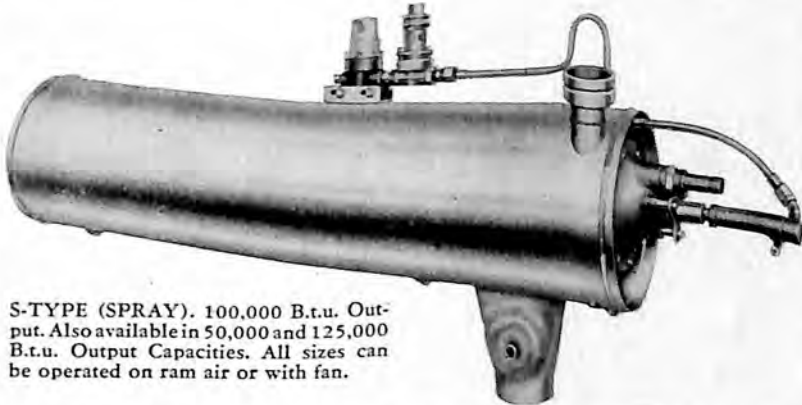

## SURFACE COMBUSTION AIRCRAFT HEATERS for High Altitude Operation

• Surface Combustion Aircraft Heaters are specified by leading American and Canadian aircraft manufacturers. They are specifically designed for operation at any altitude by employing the whirling flame combustion principle. Ignition is positive and lights at low temperatures. They are light weight and compact, simplifying application and installation. They have been flight-tested at 37,500 feet and pressure-chamber tested under conditions simulating over 50,000 feet.

PORTABLE HEATERS—Gasoline fired, are available for all ground heating purposes: Engine warming, pre-warming of cabins and cockpits, emergency heating, etc.

**SURFACE COMBUSTION**  
*Janitrol*  
**AIRCRAFT HEATERS**  
*with the whirling flame*

**SURFACE  
COMBUSTION**  
TOLEDO 1, OHIO





**TAYLOR FIBRE CO., Norristown, Pa.**

PERSONNEL: J. M. Taylor, Pres.; L. T. McCloskey, C. N. Jacobs, V. Pres.; W. H. Taylor, Secy.; R. S. McIver, Treas.

**TAYLOR-HALL WELDING CORP.,**

99 Hope Ave., Worcester, Mass.  
PERSONNEL: P. M. Hall, Pres. & Treas.

**TAYLOR INSTRUMENT COMPANIES,**

95 Ames St., Rochester, N. Y.  
PERSONNEL: L. B. Swift, Pres.; H. W. Kimmel, Secy.; H. J. Noble, Treas.; P. R. Jameson, Gen. Mgr.; F. K. Taylor, Sales Mgr.; C. D. Hart, Pur. Agt.; W. W. Lockwood, Pub. Dir.; K. K. Hubbard, Chief Engr.

**THE TAYLOR MACHINE CO.,**

1917 E. 61st St., Cleveland, O.  
PERSONNEL: W. W. Taylor, Pres. & Gen. Mgr.; M. A. Taylor, Secy. & Treas.; A. E. McGovney, Sales Mgr.; D. Stephenson, Pur. Agt. & Pub. Dir.; A. W. Taylor, Pers. Dir.; C. W. Gifford, Chief Engr.

**TAYLOR MANUFACTURING CO., 3056 W.**

Meinecke Ave., Milwaukee 10, Wisc.  
PERSONNEL: T. F. Millane, Pres. & Gen. Mgr.; C. V. Kray, Sales Mgr.; R. I. McDonald, Pur. Dir.; J. F. Millane, Pers. Dir.; H. Karweik, Chief Engr.

**THE TAYLOR-WINFIELD CORP.,**

Warren, O.  
PERSONNEL: J. A. Anderson, Pres.; W. A. Anderson, V. Pres.; N. H. Cobb, Secy.; J. D. Anderson, Treas.; T. S. Long, Acting Gen. Mgr. & Sales Mgr.; W. G. Tilsher, Prod. Mgr.; W. H. Marion, Pur. Dir.; E. E. Steigner, Pers. Dir.; R. E. Dauber, Pub. Dir.; E. J. Del Vecchio, Asst. Sales Mgr.; S. M. Humphrey, Exec. Engr.

**TAYLORCRAFT AVIATION CORP.,**

Alliance, O.  
PERSONNEL: J. C. Hart, Pres.; C. W. Elkins, Asst. to the Pres.-Sales; R. H. Wendt, V. Pres.-Engrg.; K. W. Tibbits, V. Pres.-Mfg.; D. L. Zacharias, Secy. & Treas.; M. W. Third, Asst. Treas. & Pers. Dir.; J. F. Masterson, Pub. Dir.; A. J. Dodge, Pur. Dir.

**TECHNICAL PLY-WOODS,**

228 N. LaSalle St., Chicago 1, Ill.  
PERSONNEL: J. R. Fitzpatrick, Dir. & Sales Mgr.; A. N. Carstens, Associate; M. B. Griswold, Treas. & Pur. Dir.; H. J. Hansen, Chief Engr. & Res. Dept.

**TECHNICAL PRODUCTS CO.,**

6670 Lexington Ave., Los Angeles, Calif.  
PERSONNEL: E. R. Chilcott, Pres.; F. E. Chilcott, Gen. Mgr.; G. L. Hawkins, Pur. Agt.

**TEICHER MANUFACTURING CORP.,**

136-23 34th Ave., Flushing, N. Y.  
PERSONNEL: A. A. Teicher, Pres.; G. B. Cluett, II, V. Pres.; L. L. Wilke, Secy.; L. Teicher, Treas.; K. E. Friedemann, Prod. Mgr.

**TELAUTOGRAPH CORP.,**

16 W. 61st St., New York 23, N. Y.  
PERSONNEL: W. F. Vieh, Pres.; H. Shea, Treas.; T. F. Duncan, Prod. Mgr.; J. B. Carlyon, Sales Mgr.; H. Wilkins, Pur. Dir.; A. H. Drew, Adv. Mgr.; G. T. Stanton, Chief Engr.

**TELEVISION PRODUCTS, INC., 6533 Olmsted**

Ave., Northwest Highway, Chicago, Ill.  
PERSONNEL: S. S. Schiller, Pres.; H. D. Von Jenef, V. Pres. & Chief Engr.; J. B. Atkinson, Secy.; F. Schalk, Gen. Mgr.; J. D. Ellis, Pur. Agt.; D. Sherman, Pers. Dir.

**TEMPLETON, KENLY & CO., 1020 S. Central**

Ave., Chicago 44, Ill.  
PERSONNEL: J. B. Templeton, Pres.; R. H. Webb, Pur. Dir.; A. C. Lewis, Sales Mgr.; P. J. Jakoubek, Chief Engr.

**TENNESSEE AIRCRAFT, INC.,**

126 Tenth Ave., South Nashville, Tenn.  
PERSONNEL: L. E. Reiser, Pres. & Gen. Mgr.; C. S. Ragland, V. Pres.; W. Phillips, Secy. & Treas.; C. Walden, Pur. Agt.; A. Duting, Pers. Dir.

**TENNESSEE EASTMAN CORP.,**

Kingsport, Tenn.  
PERSONNEL: P. S. Wilcox, Pres.; J. C. White, V. Pres. & Gen. Mgr.; M. K. Robinson, Secy.; J. C. Stone, Treas.; S. E. Palmer, Sales Mgr.; H. L. Ford, Pur. Dir.

**TENNEY ENGINEERING, INC.,**

8-10 Elm St., Montclair, N. J.  
PERSONNEL: D. Tenney, Pres.; A. J. Peck, Secy. & Treas.; R. Fagerlund, Prod. Mgr.; F. C. Frost, Sales Mgr.; R. Stackhouse, Pur. Dir.; V. P. O'Reilly, Pers. Dir.; T. Lopiccolo, Chief Engr.

**GEORGE A. TERRY CO.,**

356 S. Elmwood Ave., Buffalo 1, N. Y.  
PERSONNEL: G. A. Terry, Owner; A. M. Dodge, Secy.

**THE TEXAS CO.,**

135 E. 42nd St., New York 17, N. Y.  
PERSONNEL: W. S. S. Rodgers, Pres.; H. W. Dodge, V. Pres.; R. L. Saunders, Secy.; L. H. Lindeman, Treas.; M. Halpern, Prod. Mgr.; R. T. Herndon, Sales Mgr.; G. W. Orton, Pur. Dir.; C. O. Strahley, Pers. Dir.; P. C. Humphrey, Pub. Dir.; A. R. Dunphy, Asst. Adv. Mgr.; D. W. Carswell, Chief Engr.

**M. N. THACKABERRY,**

304-308 E. Third St., Los Angeles, Calif.  
PERSONNEL: M. N. Thackaberry, Owner & Treas.; R. G. Spangler, Sales Mgr. & Pur. Agt.; L. Smith, Chief Engr.

**THIOKOL CORP.,**

780 N. Clinton Ave., Trenton, N. J.  
PERSONNEL: B. L. Longstreth, Pres. & Gen. Mgr.; J. C. Patrick, V. Pres.; H. A. Richards, Secy.; J. W. Crosby, Sales Mgr.; J. C. Campbell, Pur. Agt.

**THOMPSON AIRCRAFT PRODUCTS CO.,**

Euclid, O.  
PERSONNEL: F. C. Crawford, Pres.; L. M. Clegg, Exec. V. Pres.; J. D. Wright, V. Pres., Secy. & Gen. Mgr.; A. T. Colwell, V. Pres.; J. H. Coolidge, Treas.; G. V. Sevald, Sales Mgr.; H. D. Myers, Pur. Agt.; R. S. Livingstone, Pers. Dir.; F. R. Witt, Pub. Dir.; H. D. Bubb, Chief Engr.

**THE THOMPSON GRINDER CO.,**

1534 W. Main St., Springfield, O.  
PERSONNEL: C. Baldenhofer, Pres., Treas. & Gen. Mgr.; W. G. Baldenhofer, V. Pres.; R. M. McDonough, Secy.; J. C. Wilson, Sales Mgr., Pub. Dir. & Chief Engr.; R. L. Powers, Pur. Agt. & Pers. Dir.

**THE HENRY G. THOMPSON & SON CO.,**

277 Chapel St., New Haven 5, Conn.  
PERSONNEL: D. W. Northup, Pres.; T. A. Hyde, V. Pres.; A. W. Tucker, Secy., Sales Mgr. & Adv. Mgr.; D. C. Smyth, Treas. & Pur. Dir.; M. J. Radecki, Chief Engr.

# FASTER BETTER WELDING

TAYLOR-WINFIELD HAS MET  
THE DEMAND FOR WELDERS  
THAT WILL STEP UP AIRCRAFT  
PRODUCTION WITHOUT SACRI-  
FICING QUALITY . . .



B-800  
HYDRAULIC  
FLASH-BUTT  
WELDER



ROCKER ARM  
TYPE HI-WAVE  
WELDER



TAYLOR-WINFIELD ENGINEERING  
TAKES INTO CONSIDERATION ALL  
PROBLEMS OF AIRCRAFT STRUC-  
TURAL WELDING — AND SOLVES  
THEM.



THE MOST COMPLETE LINE  
OF RESISTANCE WELDING  
EQUIPMENT IN THE COUNTRY

The **TAYLOR**  
**WINFIELD** Corporation  
WARREN, OHIO, U.S.A.

**THOMPSON PRODUCTS, INC.,**

8354 Wilcox Ave., Bell, Calif.

PERSONNEL: F. C. Crawford, Pres.; L. M. Clegg, V. Pres.; J. D. Wright, Secy.; P. D. Hileman, Gen. Mgr.; A. F. Anderson, Factory Mgr.; W. H. Carhart, Sales Mgr.; S. A. Richards, Pur. Dir.; J. R. Bair, Pers. Dir.; R. M. Rogers, Chief Engr.

**THOMPSON PRODUCTS, INC.,**

2196 Clarkwood Rd., Cleveland 3, O.

PERSONNEL: F. C. Crawford, Pres.; L. M. Clegg, Exec. V. Pres.; J. H. Coolidge, V. Pres. & Treas.; J. D. Wright, V. Pres. & Secy.; T. O. Duggan, A. T. Colwell, W. M. Albaugh, R. S. Livingstone, V. Pres.; J. M. Kerwin, Factory Mgr.; D. Graef, Prod. Mgr.; G. V. Sevald, Sales Mgr.; H. D. Myers, Pur. Dir.; R. D. Livingstone, Pers. Dir.; F. R. Witt, Adv. & Pub. Dir.; H. D. Bubbs, Chief Engr.

**THOMSON-GIBB ELECTRIC WELDING CO.,**

Lynn, Mass.

PERSONNEL: G. A. Cutter, Pres.; H. B. Warren, W. T. Ober, V. Pres.; D. J. Lyne, Secy.; A. P. Reed, Treas.; C. E. Seifert, Prod. Mgr.; I. C. Brown, Sales Mgr.; E. L. C. Clark, Adv. Mgr.; F. H. Speed, Chief Engr.

**THORDARSON ELECTRIC MANUFACTURING CO.,**

500 W. Huron St., Chicago, Ill.

PERSONNEL: R. E. Onstad, Pres. & Gen. Mgr.; L. G. Winney, V. Pres.; O. W. Storey, Secy.; W. R. Mahoney, Asst. Treas.; M. Flechsig, Prod. Mgr.; J. Beebe, Sales Mgr.; C. A. Schmidt, Pur. Dir.; T. Kissling, Pers. Dir.; E. J. Rehfeldt, Pub. Dir. & Adv. Mgr.; W. Howe, Chief Engr.

**THE THRESHER VARNISH CO.,**

1100 E. Monument Ave., Dayton, O.

PERSONNEL: C. L. Sullivan, Jr., Pres., Gen. Mgr. & Pur. Agt.; E. H. Kessler, Sales Mgr.; P. W. Blue, Pers. Dir. & Pub. Dir.; J. E. Heller, Chief Engr.

**W. HARRIS THURSTON-THURSTON CUTTING CORP.,**

40 Worth St., New York, N. Y.

PERSONNEL: W. H. Thurston, Pres.; J. G. Bausher, Sales Mgr., Dir. Airwing Prod.

**TIDE WATER ASSOCIATED OIL CO.,**

17 Battery Pl., New York, N. Y.

PERSONNEL: W. F. Humphrey, Pres.; B. L. Graves, V. Pres.; W. J. Burkner, Secy.; K. R. Hankinson, Treas.; J. D. Collins, Sales Mgr.

79 New Montgomery St., San Francisco, Calif.

PERSONNEL: L. F. Bayer, V. Pres.; P. E. Allen, Sales Mgr.

**TIETZMANN ENGINEERING CO.,**

Englewood, O.

PERSONNEL: C. Tietzmann, Pres.; W. A. Tietzmann, V. Pres., Gen. Mgr., Sales Mgr., Pur. Agt. & Pub. Dir.; D. Randolph, Secy.; M. Tietzmann, Treas.; A. Hocker, Pers. Dir.; J. A. Anderson, Chief Engr.

**THE TIMKEN ROLLER BEARING CO.,**

Canton, O.

PERSONNEL: W. E. Umstatted, Pres.; W. R. Timken, Exec. V. Pres.; L. M. Klinedinst, T. V. Buckwalter, A. M. Donze, J. E. Fick, V. Pres.; R. C. Brower, Secy. & Treas.; W. B. Moore, Dir. Sales; D. A. Bessmer, Pur. Dir.; P. J. Reeves, Adv. Mgr.; A. L. Bergstrom, Exec. Engr.

**TIMM AIRCRAFT CORP.,**

117 W. Ninth St., Los Angeles, Calif.

PERSONNEL: O. W. Timm, Pres. & Chief Engr.; R. B. Buckley, V. Pres. & Gen. Mgr.; D. P. Murdy, Secy. & Treas.; W. A. Campbell, Pub. Rel. Dir.; W. Silsby, Ind. Rel. Dir.

**TINGLEY RELIANCE RUBBER CORP.,**

903 Ross St., Rahway, N. J.

PERSONNEL: W. McCollum, Pres. & Sales Mgr.; P. N. Furber, V. Pres.; D. Armstrong, Secy.; W. Rand, Treas., Gen. Mgr. & Pur. Agt.; H. Peins, Chief Engr.

**TINNERMAN PRODUCTS, INC.,**

2038 Fulton Rd., Cleveland 13, O.

PERSONNEL: A. H. Tinnerman, Pres. & Treas.; G. A. Tinnerman, V. Pres. & Gen. Mgr.; A. T. Buttriss, Secy.; W. M. Buttriss, Sales Mgr. & Adv. Mgr.; R. Overstreet, Pur. Dir.; C. H. Judd, Chief Engr.

**TITANNE, INC.,**

Morris &amp; Elmwood Aves., Union, N. J.

PERSONNEL: E. G. Davis, Pres., Treas. & Gen. Mgr.; T. A. J. Ward, V. Pres., Secy. & Pur. Agt.; W. Bagley, Sales Mgr.

**TITFLEX, INC.,**

500 Frelinghuysen Ave., Newark 5, N. J.

PERSONNEL: E. E. Husted, Pres.; P. L. Procter, V. Pres. & Treas.; E. A. Robertson, V. Pres.; V. C. Bonardel, Contract Mgr.; J. Dunn, Works Mgr.; A. Pennington, Prod. Mgr.; C. Lane, Pur. Dir.; W. Oliver, Pers. Dir.; E. W. Allen, Jr., Pub. Dir.; D. Ingalls, Chief Engr.

**THE TOBRIN TOOL CO.,**

Plantsville, Conn.

PERSONNEL: W. F. Thomson, Pres. & Treas.; D. S. Blakeslee, V. Pres.; R. H. Brannin, Secy.; E. L. Barlow, Sales Mgr.

**TOLEDO SCALE CO.,**

Telegraph Rd., Toledo, O.

PERSONNEL: H. D. Bennett, Pres.; W. A. Fink, V. Pres. & Treas.; G. R. Bennett, V. Pres. & Gen. Mgr.; C. O. Marshall, Secy.; M. E. Holmes, Sales Mgr.; G. S. Yost, Pur. Agt.; R. H. Herron, Pers. Dir.; L. Ellingwood, Pub. Dir.; F. W. Gilchrist, Chief Engr.

**THE TOLEDO STANDARD COMMUTATOR CO.,**

2242 Smead Ave., Toledo, O.

PERSONNEL: E. D. Moon, Pres.; W. D. Moon, V. Pres.; H. R. Moon, Secy. & Treas.; A. G. Ollivier, Gen. Mgr. & Chief Engr.; F. E. Rigney, Pur. Agt.

**THE TOMKINS JOHNSON CO.,**

617 N. Mechanic St., Jackson, Mich.

PERSONNEL: A. R. Johnson, Pres.; D. M. J. Tracey, V. Pres., Gen. Mgr. & Pur. Dir.; L. E. Eberhardt, Secy.; A. M. Miller, Treas.; G. K. Watson, Prod. Mgr.; W. J. Remund, Sales Mgr.; G. B. Cranor, Chief Engr.

**THE TRANE CO.,**

Second &amp; Cameron Ave., La Crosse, Wisc.

PERSONNEL: R. N. Trane, Pres.; E. H. Erickson, V. Pres.; A. T. Holmes, Secy.; F. Hood, Treas.; D. C. Minard, Sales Mgr.; R. H. Pearce, Pur. Dir.; R. W. Gillette, Pers. Dir.; L. A. Trumble, Adv. Mgr.; R. H. Anderegg, Chief Engr.

**TRANS-AMERICAN AIRPORTS CORP.,**

271 Madison Ave., New York 16, N. Y.

PERSONNEL: E. H. Bauman, Pres., Sales Mgr., Pur. Dir., Pub. Dir. & Adv. Mgr.; B. Wallace, V. Pres.; L. Adler, Secy.; E. Bauman, Treas.

**TRANSUE & WILLIAMS STEEL FORGING**

CORP., Alliance, O.

PERSONNEL: J. R. Gorman, Pres. & Gen. Mgr.; J. C. Redmond, V. Pres.; H. C. Senour, Secy. & Treas.; E. M. Cook, Sales Mgr.; H. C. Martin, Pur. Dir.; E. H. Meeks, Pers. Dir.; L. Donnelly, Adv. Mgr.; R. Scott, Chief Engr.

**HAROLD E. TRENT CO.,**

Leverington Ave. &amp; Wilde St., Philadelphia, 27, Pa.

PERSONNEL: E. F. Ewing, Sales Mgr.

# Right ON the Button

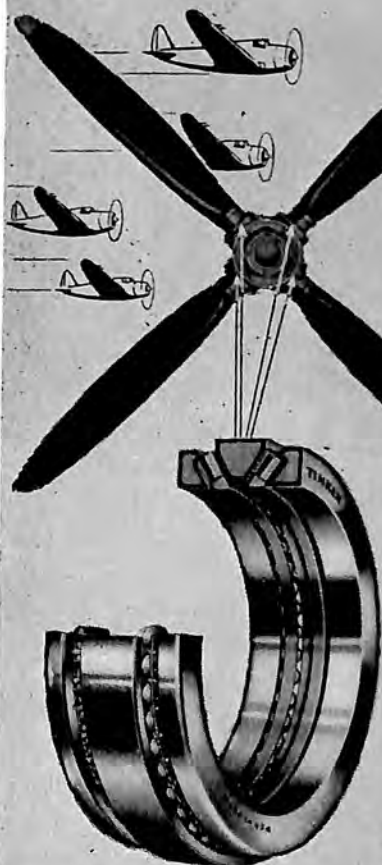

Without reservation the Timken Propeller Blade Bearing is the most difficult bearing we have ever manufactured.

The bearing surfaces must be finished unbelievably smooth otherwise the blades will not feather correctly at high propeller speeds. Every bearing is given a most severe torque test.

Weight variations between any two complete bearings are held "right on the button," otherwise bearings alone would throw propellers out of balance.

There are thousands of Timken Propeller Blade Bearings in service and they are making an excellent performance record in fighter and bomber planes.

If you are interested in propeller blade feathering bearings we welcome your consultation.

THE TIMKEN ROLLER BEARING COMPANY, CANTON, OHIO

**TIMKEN**  
TRADE-MARK REG. U. S. PAT. OFF.  
**TAPERED ROLLER BEARINGS**

**THE TRIPLETT ELECTRICAL INSTRUMENT CO., Bluffton, O.**

PERSONNEL: R. L. Triplett, Pres.; C. A. Biery, V. Pres.; L. Fenn, Prod. Mgr.; N. A. Triplett, Sales Mgr.; G. Linden, Pur. Dir.; A. R. Baker, Pers. Dir. & Adv. Mgr.

**TRIPPE MANUFACTURING CO., 564 W. Adams St., Chicago 6, Ill.**

PERSONNEL: G. Trippe, Pres.; S. H. Moss, Secy.; J. G. Cohen, Prod. Mgr.

**TROYER AIRCRAFT, 742 Bridge St., Grand Rapids, Mich.**

PERSONNEL: K. R. Troyer, Pres. & Chief Engr.

**TUBE TURNS, INC., 224 E. Broadway, Louisville 1, Ky.**

PERSONNEL: W. H. Girdler, Sr., Pres.; R. E. Fritsch, V. Pres. & Sales Mgr.; O. O. Funk, Secy. & Treas.; C. J. Hodapp, Gen. Mgr.; N. C. Dooley, Prod. Mgr.; R. J. Dilger, Pur. Dir.; W. H. Girdler, Jr., Pers. Dir.; O. C. Husted, Pub. Dir.; G. V. Wedereit, Adv. Mgr.; F. C. Smith, Chief Engr.

**TUBING SEAL-CAP, INC., 215 W. Seventh St., Los Angeles, Calif.**

PERSONNEL: R. A. Livingston, Pres.; F. W. Livermont, V. Pres. & Chief Engr.; R. L. Ames, V. Pres. & Sales Mgr.; L. Cole, Secy.; C. Rowe, Asst. Treas.

**TUBULAR RIVET AND STUD CO., Wollaston, Mass.**

PERSONNEL: E. N. Bray, Pres.; L. P. Worcester, V. Pres. & Sales Mgr.; F. A. Edmands, Treas.; B. C. Edmands, Prod. Mgr.

**TUBULAR SERVICE CORP., 32 Broadway, New York, N. Y.**

PERSONNEL: H. L. Wanderman, Pres. & Adv. Mgr.; M. L. Rosenblum, V. Pres. & Gen. Mgr.; A. W. Brand, Secy. & Treas.; E. Lerner, Pers. Dir.; I. J. Freedman, Chief Engr.

**TUCKER AVIATION CO., 110 N. Park St., Ypsilanti, Mich.**

PERSONNEL: P. T. Tucker, Pres. & Sales Mgr.; W. M. Harris, Secy.; M. R. Diggs, Treas.; E. E. Schaffer, Gen. Mgr.; F. W. Glatt, Pur. Agt.; C. N. Hazlewood, Chief Engr.

**TURBO ENGINEERING CORP., Hancock & Lalor Sts., Trenton, N. J.**

PERSONNEL: G. E. Besler, Pres.; R. Birmann, V. Pres., Secy. & Chief Engr.; L. S. Rice, Treas.; P. Doxey, Works Mgr.; E. J. Schwarz, Pur. Agt.; F. Jarrell, Pers. Dir.

**TURCO PRODUCTS, INC., 6135 S. Central Ave., Los Angeles, Calif.**

PERSONNEL: S. G. Thornbury, Pres. & Treas.; R. Sanders, V. Pres., Gen. Mgr. & Sales Mgr.; E. S. Harrington, Secy.; J. C. Walker, Pur. Agt.; D. M. LeVasseur, Pers. Dir.; S. E. Goldsmith, Pub. Dir.; C. A. Stine, Chief Engr.

**TUTHILL SPRING CO., 760 Polk St., Chicago 7, Ill.**

PERSONNEL: H. T. Moore, Pres., Gen. Mgr., Sales Mgr. & Adv. Mgr.; W. S. Van Bergen, V. Pres., Prod. Mgr., Pur. Dir. & Chief Engr.; J. H. Schmidt, Secy.; O. C. Nuss, Treas.

**TWIN CITY TOOL CO., 2520 Marshall St., N. E., Minneapolis, Minn.**

PERSONNEL: S. J. Leba, Pres. & Gen. Mgr.; J. J. Leba, Secy., Treas. & Chief Engr.

**TYLER FIXTURE CORP., Niles, Mich.**

PERSONNEL: J. Tyler, Pres., Gen. Mgr. & Sales Mgr.; C. P. Eliason, V. Pres.; G. H. Mayhew, Secy. & Treas.; E. W. Kent, Prod. Mgr.; H. C. Davis, Pur. Dir.; S. D. Vanderweg, Pers. Dir., Pub. Dir. & Adv. Mgr.

**TYSON ROLLER BEARING CORP., Massillon, O.**

PERSONNEL: R. H. Maxson, Pres. & Gen. Mgr.; E. R. Earnest, V. Pres. & Secy.; J. K. Colgate, Treas.; H. J. Deal, Sales Mgr.; L. W. Weddell, Pub. Dir.; W. Rastetter, Chief Engr.

## U

**U. S. INDUSTRIAL CHEMICALS, INC., 60 E. 42nd St., New York, N. Y.**

PERSONNEL: C. S. Munson, Pres.; G. Haskell, V. Pres.; B. H. Young, Secy.; K. Peck, Treas.; L. A. Keane, Sales Mgr.; E. R. Lawrence, Pur. Agt.

**U. S. TOOL CO., INC., Ampere (East Orange) N. J.**

PERSONNEL: C. Todd, Pres. & Treas.; A. E. Borton, V. Pres.; W. P. Powers, Secy.; J. Armour, Gen. Mgr.; F. Koch, Prod. Mgr.; P. E. McKeith, Sales Mgr., Pub. Dir. & Adv. Mgr.; W. Downey, Pur. Dir.; R. G. Bliss, Pers. Dir.; E. Grimm, Chief Engr.

**UNIFORM HOOD LACE CO., 1609 College Ave., Indianapolis, Ind.**

PERSONNEL: J. L. Anthony, Pres.; L. M. Anthony, Secy. & Treas.; C. Jacks, Gen. Mgr.; J. B. Given, Prod. Mgr.

**UNION AIRCRAFT PRODUCTS CORP., 380 Second Ave., New York, N. Y.**

PERSONNEL: I. M. Felt, Pres.; E. Ellinger, Jr., Exec. V. Pres.; D. Fordsman, V. Pres.; S. C. Jones, Secy. & Treas.

**UNION MANUFACTURING CO., 296 Church St., New Britain, Conn.**

PERSONNEL: C. S. Neumann, Pres., Gen. Mgr. & Sales Mgr.; C. S. Mueller, Secy.; H. H. Wheeler, Treas. & Pur. Agt.; C. N. Baisden, Pers. Dir.; G. C. Prime, Chief Engr.

**UNITED AIRCRAFT PRODUCTS, INC., Dayton 1, O.**

2929 Santa Fe Ave., Los Angeles, Calif.  
PERSONNEL: F. G. Sorensen, Pres. & Gen. Mgr.; P. W. Christensen, F. W. Wilkens, V. Pres.; J. Shotwell, Secy. & Treas.; W. W. Cowan, Works Mgr.; E. C. Hartleb, Sales Mgr.; J. A. Connolly, Pur. Dir.; L. K. Sherrill, Pers. Dir.; A. C. Hoffman, Chief Engr.

**UNITED-CARR FASTENER CORP., 31 Ames St., Cambridge 42, Mass.**

PERSONNEL: A. W. Kimbell, Pres. & Gen. Mgr.; C. L. Hall, V. Pres.; A. S. Boynton, Secy.; J. J. Ellsworth, Treas.; D. J. Rogers, Prod. Mgr.; G. S. Maynard, Sales Mgr.; F. J. Ross, Pur. Dir.; W. A. Nye, Pers. Dir.; R. O. Chaffee, Chief Engr.; A. W. Rice, Jr., Engr. Service Mgr.

**THE UNITED STATES ELECTRICAL TOOL CO., 1050 Findlay St., Cincinnati 14, O.**

PERSONNEL: J. C. Smith, Pres. & Gen. Mgr.; G. E. Smith, V. Pres. & Treas.; J. M. Hogan, Secy.; G. D. Behlen, Prod. Mgr. & Chief Engr.; J. D. O'Flaherty, Sales Mgr. & Adv. Mgr.; H. E. Neske, Pur. Dir.

**UNITED STATES GAUGE CO., 14 Wall St., New York, N. Y.**

PERSONNEL: J. W. Place, Pres.; W. G. Ziegler, Sales Mgr.; F. D. Heyder, Pur. Agt.; R. F. Stackel, Pers. Dir.; M. Klein, Chief Engr.

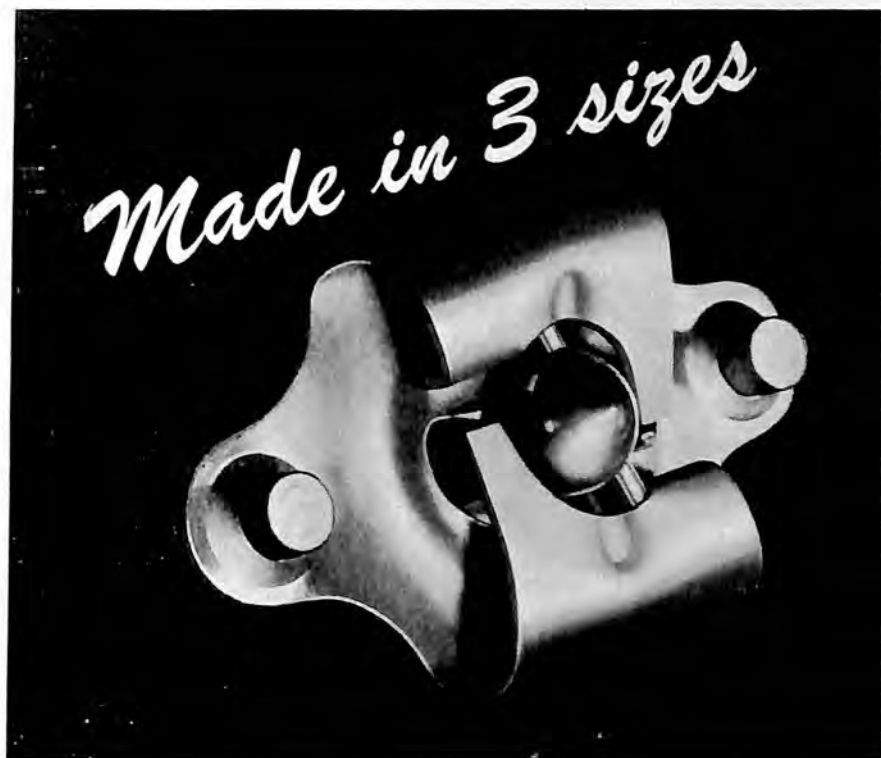

## THE *Airloc* FASTENER

THERE IS a correct size of Airloc for every application that calls for a cowling fastener...  $\frac{3}{4}$ -inch, 1-inch and  $1\frac{3}{8}$ -inch. They test to 300, 750 and 1050 lbs. tensile strength respectively. Selecting the exact size you need will save the unnecessary weight of using a larger fastener where a smaller one will meet requirements. The Airloc's compact design saves space with no loss of security.

NEW CATALOG. Send for a copy of the new Airloc Catalog complete in every detail. Address Dept. Y-44.

**UNITED-CARR FASTENER CORP.**  
CAMBRIDGE 42, MASSACHUSETTS



**THE UNITED STATES GRAPHITE CO.,**

1621 Holland Ave., Saginaw, Mich.  
 PERSONNEL: H. R. Wickes, Pres.; L. Field, V. Pr. & Gen. Mgr.; O. R. Miller, Secy.; H. E. Ward Treas.; S. Bolton, Sales Mgr.; C. J. Powers, Pur. Agt.; H. F. Mitchel, Chief Engr.

**UNITED STATES PLYWOOD CORP.,**

616 W. 46th St., New York 19, N. Y.  
 PERSONNEL: L. Ottinger, Pres.; R. C. Wilcox, V. Pres.; S. Ottinger, Secy.; W. Leary, Treas. & Pers. Dir.; C. Brown, Gen. Mgr.; W. Bailey, C. Yerkes, Prod. Mgrs.; S. W. Antoville, Sales Mgr.; C. C. Holdsworth, Pur. Dir.; J. G. Berens, Pub. Dir.; R. S. Lowell, Adv. Mgr.; O. S. Tuttle, Chief Engr.

**UNITED STATES RUBBER CO.,**

1230 Sixth Ave., New York 20, N. Y.  
 PERSONNEL: H. E. Smith, Pres.; E. Burkman, Secy.; A. Surkamp, Treas.; G. M. Tisdale, Pur. Dir.; H. Kaiser, Pers. Dir.; R. Wilks, Pub. Dir.; T. H. Young, Adv. Mgr.; C. A. Ostling, Chief Engr.

**UNITED STATES VARNISH CO.,**

Hasbrouck Heights, N. J.  
 PERSONNEL: H. G. Hose, Pres.

**UNITED TRANSFORMER CO.,**

150 Varick St., New York 13, N. Y.  
 PERSONNEL: I. A. Mitchell, Pres., Treas., Pub. Dir. & Adv. Mgr.; S. L. Baraf, V. Pres., Secy. & Sales Mgr.; R. E. Cochran, Gen. Mgr. & Pur. Dir.; L. A. Goldstone, Prod. Mgr.; H. B. Golden, Pers. Dir.; L. G. Burnell, Chief Engr.

**UNIVERSAL BORING MACHINE CO.,**

Hudson, Mass.  
 PERSONNEL: F. S. Jefferies, Pres.; C. A. Clarke, V. Pres.; A. H. Goodsell, Secy. & Treas.

**UNIVERSAL BUILDING PRODUCTS CORP.,**

2625 Elm St., Dallas, Tex.  
 PERSONNEL: J. P. Travis, Pres. & Gen. Mgr.; C. R. Harrison, V. Pres. & Sales Mgr.; E. Williams, Secy. & Treas.; R. K. McLaury, Dir. Pur.; H. W. Strong, Dir. Pub. Rel. & Adv.; G. W. White, Pub. Dir.; A. Rickard, Chief Engr.

**UNIVERSAL FIXTURE CORP.,**

135 W. 23rd St., New York, N. Y.  
 PERSONNEL: S. Brimberg, Pres.; S. Goldberg, V. Pres.; P. Rosenberg, Secy. & Treas.; E. Macauley, Gen. Mgr.

**UNIVERSAL MICROPHONE CO.,**

424 Warren Lane, Inglewood, Calif.  
 PERSONNEL: J. L. Fouch, Pres.; C. L. Sly, V. Pres. & Treas.; D. D. Allen, Secy.; R. Hannan, Prod. Mgr.; H. Baumgarten, Pur. Dir.; G. Schmidt, Pers. Dir.; R. L. Power, Adv. Mgr.; L. Willyard, Chief Engr.

**THE UNIVIS LENS CO.,**

401 Leo St., Dayton, O.  
 PERSONNEL: J. R. Silverman, Pres. & Gen. Mgr.; G. F. Stanley, V. Pres.; M. H. Stanley, Exec. V. Pres., Secy. & Treas.; R. Marks, Prod. Mgr.; V. H. Hancock, Sales Mgr.; J. Murray, Pur. Dir.; G. Campbell, Pers. Dir.; L. V. Browne, Pub. Dir.; W. Savage, Adv. Mgr.; R. E. Allan, Chief Engr.

**UTICA DROP FORGE & TOOL CORP.,**

2415 Whitesboro St., Utica 4, N. Y.  
 PERSONNEL: E. Norris, Pres. & Treas.; W. V. Daugherty, V. Pres.; F. P. Tenney, V. Pres. & Sales Mgr.; D. L. Tyler, Secy.; A. L. Evans, Pur. Dir.; V. W. Bannigan, Pers. Dir.; W. A. Barnes, Chief Engr.

**UTILITY ELECTRIC STEEL FOUNDRY,**

3334 E. Slauson Ave., Vernon, Calif.  
 PERSONNEL: E. W. Bennett, Pres.; G. L. Knox, V. Pres.; H. C. Bennett, Secy. & Treas.; E. C. Hummel, Gen. Mgr.; J. C. Kidd, Sales Mgr.

**UTILITY FAN CORP.,**

4851 S. Alameda St., Los Angeles, Calif.  
 PERSONNEL: B. B. Breslow, Pres. & Gen. Mgr.; M. Breslow, V. Pres., Sales Mgr. & Pub. Dir.; B. Harris, Secy.; H. A. Goldman, Treas.; S. G. Scott, Pur. Agt.; A. Silver, Pers. Dir.; H. Sachs, Chief Engr.

**UXBRIDGE WORSTED CO., INC.,**

Uxbridge, Mass.  
 PERSONNEL: H. J. Walter, Treas.; G. P. Carver, Jr., Pur. Agt.

## V

**V. & E. MANUFACTURING CO.,**

P. O. Box 950, Pasadena 20, Calif.  
 PERSONNEL: F. E. Vaughan, Partner, Gen. Mgr., Sales Mgr. & Adv. Mgr.; F. G. Eubanks, Partner & Prod. Mgr.; H. Pursel, Pur. Dir.; E. M. Eubanks, Perc. Dir.; H. Harris, Chief Engr.

**VALENTINE & CO. INC.,**

11 E. 36th St., New York, N. Y.  
 PERSONNEL: T. J. Campbell, Pres.; G. M. Bralla, Secy. & Treas.; A. L. Clark, Sales Mgr., Aeronautical Div.; H. N. Plumb, Jr., Pur. Agt.

**VALVOLINE OIL CO.,**

453 Culvert St., Cincinnati 2, O.  
 PERSONNEL: G. P. Doll, Pres. & Gen. Mgr.; C. J. Leroux, V. Pres., Treas. & Sales Mgr.; E. H. Shepard, Asst. Secy. & Pur. Dir.; C. W. Luton, Prod. Mgr.-Refinery; C. C. Gould, Secy.; G. L. Service, Pub. Dir. & Adv. Mgr.; L. A. Calkins, Chief Engr.

**VAN NORMAN CO.,**

3640 Main St., Springfield, Mass.  
 PERSONNEL: J. Y. Scott, Pres. & Treas.; L. F. Lunderup, V. Pres. & Prod. Mgr.; F. D. Van Norman, Secy.; H. G. Hoglund, Sales Mgr.-Machine Tools; C. R. Crowder, Sales Mgr.-Automotive Equipment; C. A. Thompson, Pur. Dir.; F. P. Healy, Chief Engr.

**VAPOR CAR HEATING CO., INC.,**

1450 Railway Exchange, Chicago, Ill.  
 PERSONNEL: W. L. Conwell, Pres.; A. D. Bruce, Exec. V. Pres.; O. A. Rosboro, Secy.; D. W. Fox, Treas.; L. H. Gillick, Sales Mgr.; E. A. Russell, Chief Engr.

**VARD, INC.,**

2961 E. Colorado St., Pasadena, Calif.  
 PERSONNEL: V. B. Wallace, Pres.; H. E. Robinson, V. Pres. & Prod. Mgr.; H. M. Bray, Secy., Treas. & Sales Mgr.; N. O. Nelson, Pur. Dir.; R. D. Tyler, Adv. Mgr.

**THE VARIETY AIRCRAFT CORP.,**

2901 W. Third St., Dayton, O.  
 PERSONNEL: L. M. Coppock, Pres. & Gen. Mgr.; E. J. McBride, V. Pres.; C. A. Coppock, Secy., Treas. & Pur. Agt.; E. A. Johnson, Sales Mgr.; A. J. King, Pers. Dir.; E. C. Yount, Chief Engr.

**VASCOLOY-RAMET CORP.,**

800 Market St., Waukegan, Ill.  
 PERSONNEL: R. J. Aitchison, Pres.; A. J. Dowe, F. H. Driggs, V. Pres.; E. F. Radke, Secy. & Treas.; J. A. Fraser, Asst. Sales Mgr.; P. J. Guentherman, Prod. Mgr.; H. B. Clark, Gen. Sales Mgr.; C. G. Howard, Asst. Sales Mgr.; H. W. Highriter, Lab. Dir.; N. E. Bradley, Adv. Mgr.

# Low-Pressure Molded Plastics

**Weldwood's latest development for the aircraft industry...**



← **LOW PRESSURE MOLDED PLASTICS**—This paraboloid is a Weldwood low-pressure, all-plastic molding now in war use. Parts to specification can be low-pressure molded using impregnated papers, fabrics, glass cloths and wood veneers.

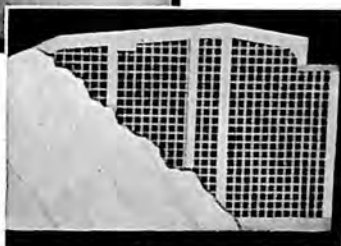

← **FABRICATED WELDWOOD SAVES METAL, SAVES WEIGHT**—Bomber floors, partitions, wing tips, navigators' tables and other aircraft parts are produced in a special Fabricated Parts Plant.

➔ **MOLDED WELDWOOD SPEEDS AIRCRAFT PRODUCTION**—This photo shows resin-coated veneer sheets being conformed to mandrels prior to cooking. Two plants are devoted exclusively to molding Weldwood.



➔ **FLAT WELDWOOD CONSTRUCTION SAVES TIME**—Light to handle yet pound for pound as strong as steel, flat Weldwood serves the aircraft industry in many ways. Illustrated is an aileron produced by a leading plane manufacturer.

Write now for complete information on Weldwood for aircraft.

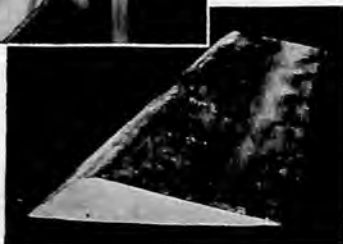

## **WELDWOOD Plywood**

*Weldwood Plywood and Plywood Products are manufactured and marketed by*

**UNITED STATES PLYWOOD CORPORATION**  
New York, N. Y.

*Waterproof Weldwood, so marked, is bonded with phenol formaldehyde synthetic resin. Other types of water-resistant Weldwood are manufactured with extended urea resins and other approved bonding agents. Molded Weldwood products are made by The Vidal Process U. S. Patent No. 2073290. The services of qualified engineers, chemists and wood technologists are available.*



**VEEDER-ROOT INC.,** Hartford 2, Conn.  
PERSONNEL: G. H. Anthony, Pres.; J. H. Chaplin, V. Pres. & Sales Mgr.; C. F. Pendlebury, Secy.; C. G. Allyn, Treas.; K. D. Graham, Prod. Mgr.; J. M. Brown, Pur. Dir.; R. W. Bailey, Pers. Dir.; E. B. Smith, Adv. Mgr.; H. L. Spaunburg, Chief Engr.

**THE VELLUMOID CO.,**  
54 Rockdale St., Worcester, Mass.  
PERSONNEL: R. B. Stanley, Pres.; L. Wald, V. Pres., Gen. Mgr. & Pur. Agt.; W. W. Webster, Treas.; C. S. Livingstone, Sales Mgr.

**VERSON ALLSTEEL PRESS CO.,**  
1363 E. 93rd St., Chicago 19, Ill.  
PERSONNEL: D. C. Verson, Pres. & Treas.; J. Verson, V. Pres. & Secy.; P. B. Duggan, Gen. Mgr.; H. Duxler, Prod. Mgr.; A. C. Ortman, Sales Mgr.; H. G. Wiggins, Pur. Dir.; N. Dillman, Pers. Dir.; F. J. Heid, Pub. Dir. & Adv. Mgr.; A. Clements, Chief Engr.

**VICKERS, INC.,**  
1400 Oakman Blvd., Detroit, Mich.  
PERSONNEL: H. F. Vickers, Pres.; K. R. Herman, V. Pres. & Gen. Mgr.; F. T. Harrington, V. Pres. & Sales Mgr.; J. F. Forster, Treas.; R. M. McCabe, Pur. Agt.; L. R. Twyman, Pub. Dir.; R. C. Griffith, Mgr., Aircraft Products Div.

**VICTOR EQUIPMENT CO.,**  
844 Folsom St., San Francisco 7, Calif.  
PERSONNEL: L. W. Stettner, Pres. & Gen. Mgr.; E. L. Mathy, V. Pres., Pub. Dir. & Adv. Mgr.; W. S. Fulwider, Secy. & Treas.; E. A. Daniels, Sales Mgr.; W. Kothgassner, Pur. Dir.; E. B. Stinson, Chief Engr.

**VICTOR MANUFACTURING & GASKET CO.,** 5750 Roosevelt Rd., Chicago, Ill.  
PERSONNEL: J. H. Victor, Pres.; G. Victor, V. Pres.; T. D. Huff, Secy.; G. McAninch, Treas.; A. A. Frymark, Gen. Mgr.; C. C. Secrist, Sales Mgr.; O. W. Clifton, Pur. Agt.; O. C. Nichols, Pers. Dir.; M. L. Liston, Pub. Dir.; A. J. Auwers, Chief Engr.

**VICTOR METAL PRODUCTS CORP.,**  
196 Diamond St., Brooklyn, N. Y.  
PERSONNEL: J. Kronman, Pres.; L. Baron, Secy.; H. Spurn, Pur. Dir.; A. Jaris, Pers. Dir.

**VIDAL RESEARCH CORP.,**  
Central Airport, Camden, N. J.  
PERSONNEL: E. L. Vidal, Pres.; L. J. Marhoefer, V. Pres. & Chief Engr.; H. D. Starr, V. Pres. & Secy.; T. Epprecht, Treas.; H. Coleman, Sales Mgr.; H. Plasket, Pur. Agt.; R. Halbert, Pers. Dir.; P. Christian, Pub. Dir.

**VIDE PRODUCTS,**  
1960 E. 48th St., Vernon, Calif.  
PERSONNEL: M. McGillivray, Gen. Mgr.; C. Willoughby, Compt.; D. Place, Pers. Dir.; L. Score, Chief Engr.

**THE VIMALERT CO., LTD.,**  
90 Forrest St., Jersey City, N. Y.  
PERSONNEL: R. Cuse, Pres.; H. A. Schaufelberger, V. Pres. & Treas.; H. Shapiro, Secy.; H. H. Butler, Prod. Mgr.; R. H. Clarke, Chief Engr.

**VINCO CORP.,**  
8855 Schaefer Highway, Detroit 27, Mich.  
PERSONNEL: J. J. Osplack, Pres.; E. E. Butler, Exec. V. Pres. & Sales Mgr.; R. A. Putnam, V. Pres.; A. S. Lloyd, Secy. & Treas.; G. A. Secord, Gen. Mgr.; W. P. Head, Pur. Dir.; H. Pilsen, Pers. Dir.; R. G. Cooper, Pub. Dir. & Adv. Mgr.; C. B. Smith, Chief Engr.

**VIRGINIA RUBATEX, DIV. OF SALTA CORP.,** 1 Exchange Pl., Jersey City, N. J.  
PERSONNEL: W. L. Smith, Pres.; S. A. Odum, V. Pres.; M. C. Mulloy, Secy.; C. A. Warden, Treas.; H. F. Gremmel, Sales Mgr.; G. H. Cornelius, Pur. Agt.; R. L. Overstreet, Chief Engr.

**THE VLCEK TOOL CO.,**  
3001 E. 87th St., Cleveland, O.  
PERSONNEL: F. J. Vlcek, Pres.; E. C. Koster, V. Pres. & Gen. Mgr.; D. B. Wilson, Secy.; H. F. Vlcek, Treas.; E. Krall, Sales Mgr.; F. Tkach, Pur. Agt.; J. Nichta, Pers. Dir.; J. Pazovrek, Chief Engr.

**VOGES MFG. CO., INC.,**  
99th St. & 103rd Ave., Ozone Park, N. Y.  
PERSONNEL: F. Voges, Pres. & Treas.; F. W. Voges, V. Pres., Secy. & Gen. Mgr.

**THE JOHN W. VOGLER CO., INC.,**  
1218 Olive St., St. Louis, Mo.  
PERSONNEL: J. W. Vogler, Pres. & Treas.; H. Duetscher, V. Pres.; A. L. Vogler, Secy.; C. D. Green, Sales Mgr. & Chief Engr.

**VONNEGUT MOULDER CORP.,**  
1815 Madison Ave., Indianapolis, Ind.  
PERSONNEL: A. Vonnegut, Pres., Treas. & Gen. Mgr.; R. W. Smart, V. Pres. & Sales Mgr.; W. E. Stroup, Secy.; J. H. Weisenauer, Pur. Agt.; J. N. Clyne, Pers. Dir. & Chief Engr.; V. L. Lee, Pub. Dir.

---

## W

---

**WABASH APPLIANCE CORP.,**  
345 Carroll St., Brooklyn 31, N. Y.  
PERSONNEL: A. M. Parker, Pres.; O. Foell, V. Pres. & Gen. Mgr.; A. Adler, Secy.; R. L. Adler, Treas.; J. Greenberg, Prod. Mgr.; W. R. Freeman, Sales Mgr.; J. Taylor, Pur. Dir.; M. Levy, Pers. Dir.; H. Spence, Pub. Dir. & Adv. Mgr.; L. Anderson, Chief Engr.

**PAUL G. WAGNER CO.,** 2865 E. Washington Blvd., Los Angeles, Calif.  
PERSONNEL: P. G. Wagner, Owner; R. C. Wagner, Office Mgr.; W. F. Wagner, Gen. Supt.

**WAGNER ELECTRIC CORP.,**  
6400 Plymouth Ave., St. Louis, Mo.  
PERSONNEL: P. B. Postlethwaite, Pres.; J. H. Devor, V. Pres.; J. W. Westcott, Secy.; V. W. Bergenthal, Treas.; A. H. Timmerman, Gen. Mgr.; J. A. Gelzer, Sales Mgr.; J. D. Eby, Pur. Agt.; G. W. Brown, Pers. Dir.; C. B. Dietrich, Pub. Dir.; B. Dick, Chief Engr.

**CHARLES WAGNER LITHO MACHINERY CO. DIV. OF NATIONAL STANDARD CO.,** 51 Park Ave., Hoboken, N. J.  
PERSONNEL: W. H. Parkin, Pres.; A. H. Johnson, V. Pres.; A. Miller, Secy.; J. A. Cooke, Treas.; C. F. Scheehle, Jr., Div. Mgr.; J. De Garmo, Sales Mgr.; C. E. Drake, Pur. Agt.; J. A. Ward, Pers. Dir.; R. C. Pierce, Chief Engr.

**E. R. WAGNER MANUFACTURING CO.,**  
4611 N. 32nd St. Milwaukee, Wisc.

**WAILES DOVE-HERMISTON CORP.,**  
Westfield, N. J.  
PERSONNEL: L. Stuart, Pres.; W. H. T. Thornhill, V. Pres. & Sales Mgr.; L. H. deBeauchamp, V. Pres., Treas. & Pur. Dir.; F. R. Stovekin, Secy.

# Heli-Coil

## SCREW THREAD INSERTS

Used With 'NF' and 'NC' Screws and Studs For Original Installations, Salvage and Maintenance in Aircraft Engines and Parts

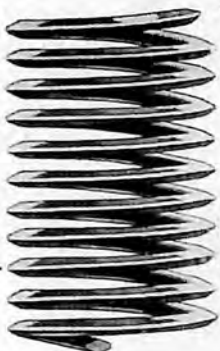

"Heli-Coil" Screw Thread Inserts provide a simple and inexpensive method of protecting tapped threads in light metals and plastics against abrasion, stripping and seizing. Furnished in stainless steel or phosphor bronze, they can be quickly installed with hand or power tools. Manufacturers of aircraft engines and accessories use "Heli-Coil" Inserts in applications where solid screw bushings were used previously.

### The "Aero-Thread" System

The "Aero-Thread" Screw Thread System uses screws or studs with a circular thread form to engage precision-shaped phosphor bronze or stainless steel helical coil inserts in the tapped threads. Such fastenings have 100% more dynamic strength and 25% more static strength than conventional fastenings.

THE SCREW SYSTEM WITH THE ANTI-FRICTION THREAD LINING



U.S. and Foreign Patents Issued and Pending.

**AIRCRAFT SCREW PRODUCTS COMPANY, INC.**  
47-23 35th STREET • LONG ISLAND CITY, N.Y.

by

Victor

Plastics

MOLDED  
ROLLERS

Metals

STAMPINGS  
IMPACT EXTRUSIONS

VICTOR METAL PRODUCTS CORP., 190 Diamond St., Brooklyn, N. Y.

**WALDES KOH-I-NOOR INC.,**

Long Island City, N. Y.

PERSONNEL: S. Waldes, Pres.; H. Axthelm, V. Pres. & Gen. Mgr.; H. J. Cooke, Secy. & Sales Mgr.; M. M. Miller, Treas.; B. Brozek, Prod. Mgr.; L. Wolf, Pur. Agt.; L. Amsterdam, Pers. Dir.; C. K. Rudman, Pub. Dir. & Adv. Mgr.; H. T. Wines, Chief Engr.

**WALES-STRIPPIT CORP.,**

345 Payne Ave., N. Tonawanda, N. Y.

PERSONNEL: G. F. Wales, Pres.; C. C. Fichtner, V. Pres., Treas. & Adv. Mgr.; C. F. Michel, Secy. & Pur. Dir.; H. K. Beebe, Works Mgr.; A. Wasserman, Prod. Mgr.; J. S. Andrews, Sales Mgr. & Chief Engr.; H. Rook, Pers. Dir.

**WALKER-TURNER CO., INC.,**

Plainfield, N. J.

PERSONNEL: W. B. Turner, Pres.; J. A. Carey, V. Pres.; H. J. Fink, Treas. & Sales Mgr.; E. T. Walker, Treas.; A. D. Bernard, Pur. Agt.; W. P. Ocenasek, Chief Engr.

**WALLACE ENGINEERING CO.,**

3640 W. 135th St., Hawthorne, Calif.

PERSONNEL: F. L. Wallace, Pres. & Gen. Mgr.; W. Edwards, Chief Engr.

**WALLACE SUPPLIES MFG. CO., 1300-12**

W. Diversey Pkway., Chicago, Ill.

PERSONNEL: E. Metterhausen, Pres.; E. J. De Witt, V. Pres.; E. A. Ptack, Sales Mgr.; W. H. Hannan, Pur. Agt.; F. J. Lammers, Chief Engr.

**WAMSUTTA MILLS, New Bedford, Mass.**

PERSONNEL: C. E. Broughton, Pres.; O. M. Dunham, Treas.; D. F. Horne, Sales Mgr.; C. P. Harrington, Pur. Agt.

**WARD LEONARD ELECTRIC CO.,**

4747 Bronx Blvd., Bronx, N. Y.

PERSONNEL: L. Kebler, Pres.; D. J. Burns, V. Pres.; L. H. Haight, Secy. & Treas.; G. A. Harrington, Prod. Mgr.; A. A. Berard, Sales Mgr.; C. Otis, Pur. Agt.; D. Guthrie, Pers. Dir.; J. R. Jones, Adv. Mgr.; W. W. Miller, Chief Engr.

**THE WARD PRODUCTS CORP.,**

1523 E. 45th St., Cleveland, O.

PERSONNEL: R. N. Wiessenberger, Pres. & Gen. Mgr.; H. R. Wiessenberger, V. Pres., Secy. & Sales Mgr.; A. G. Wiessenberger, Treas.; L. V. Coburn, Pur. Agt.; H. Ross, Pers. Dir.; J. Altmayer, Pub. Dir. & Chief Engr.

**WARMAN STEEL CASTING CO.,**

6100 S. Boyle Ave., Los Angeles, Calif.

PERSONNEL: F. D. Wild, Pres. & Treas.; W. P. McGervey, Jr., V. Pres.; H. T. Adams, Secy.; C. B. Callomon, Sales Mgr.; J. C. Meyer, Pur. Agt.; W. B. McCartney, Pers. Dir.

**WARNER AIRCRAFT CORP.,**

20263 Hoover Ave., Detroit, Mich.

PERSONNEL: W. O. Warner, Pres. & Gen. Mgr.; L. A. Faunce, V. Pres., Sales Mgr. & Pub. Dir.; W. J. Jarvie, Secy. & Treas.; R. F. Irwin, Pur. Agt.; L. Gendernalik, Pers. Dir.; L. A. Majneri, Chief Engr.

**WARNER MANUFACTURING CO.,**

666 Hawthorne St., Glendale 4, Calif.

PERSONNEL: T. W. Warner, Sr., Pres.; T. W. Warner, Jr., V. Pres., Secy., Treas. & Gen. Mgr.; E. Discoe, Prod. Mgr.; K. E. Raife, Sales Mgr.; R. L. Sherer, Pur. Dir.; J. Blevins, Pers. Dir.; G. Barnett, Pub. Dir. & Adv. Mgr.; M. Owen, Chief Engr.

**THE WASHBURN CO.,**

28 Union St., Worcester, Mass.

PERSONNEL: J. S. Tomajan, Pres.; A. G. Andrews, V. Pres.; N. Hood, Secy. & Treas.; R. G. Hess, Prod. Mgr.; E. H. Gorton, Sales Mgr. & Adv. Mgr.; J. A. Prouty, Pur. Dir.; R. H. Chadwick, Chief Engr.

**WASELL ORGANIZATION, Westport, Conn.**

PERSONNEL: F. L. Wassell, W. D. Wassell, R. W. Watts, Partners; R. W. Watts, Sales Mgr.; A. E. Coley, Pur. Agt.; S. R. Ellis, Adv. Mgr.

**WAUKESHA MOTOR CO., Waukesha, Wisc.**

PERSONNEL: J. E. DeLong, Pres. & Gen. Mgr.; J. B. Fisher, V. Pres. & Chief Engr.; C. P. Ross, Secy. & Treas.; G. R. Evans, Prod. Mgr.; J. G. Swain, Sales Mgr.; L. F. Whisler, Pur. Dir.; J. R. Matters, Pers. Dir.; P. C. Ritchie, Pub. Dir. & Adv. Mgr.

**WAYNE CHEMICAL PRODUCTS CO.,**

9400 A.C. Copeland Ave., Detroit 17 Mich.

PERSONNEL: E. G. Behr, Pres. & Gen. Mgr.; K. G. Behr, V. Pres.; W. L. Behr, Secy. & Treas.; W. C. Dilloway, Prod. Mgr.

**THE WEATHERHEAD CO.,**

300 E. 131 St., Cleveland, O.

PERSONNEL: A. J. Weatherhead, Jr., Pres.; H. I. Lewis, Exec. V. Pres.; J. Reavis, Secy.; E. Ferguson, Treas.; C. H. Weatherhead, Prod. Mgr.; H. Church, Sales Mgr. Aviation Div.; C. Craig, Pur. Dir.; G. P. Robers, Pub. Dir. & Adv. Mgr.; A. Abramaska, Chief Engr.

**WEBER SHOWCASE & FIXTURE CO., INC.,**

5700 Avalon Blvd., Los Angeles, Calif.

PERSONNEL: K. Weber, Pres.; E. V. Williams, V. Pres.; I. S. Summerfield, Secy.; F. Weber, Jr., Treas.; F. Schwind, Gen. Mgr.; A. Johnson, Sales Mgr.; J. P. Hoffman, Pur. Agt.; D. Hülke, Pers. Dir.; D. Mack, Pub. Dir.; B. Pruett, Chief Engr.

**WEEMS SYSTEM OF NAVIGATION,**

Randall House, Annapolis, Md.

PERSONNEL: M. T. Weems, Pres.; A. A. Illyne, Exec. Secy.; F. D. Johnson, H. R. Rich, Secys.

**WEIMER METAL CRAFTS CORP., Imperial**

Power Bldg., Penn Ave. &amp; Barbeau St., Pittsburgh, Pa.

PERSONNEL: R. C. Sproul, Trustee; F. J. McClaskey, Gen. Mgr., Sales Mgr. & Pur. Agt.

**WELLINGTON SEARS CO.,**

65 Worth St., New York, N. Y.

PERSONNEL: H. L. Bailey, Pres.; N. S. Hope, V. Pres.; C. A. Sweet, Secy.; C. Richmond, Treas.; W. O. Hay, Sales Mgr.; N. Horn, Pub. Dir.

**THE WELLMAN BRONZE & ALUMINUM CO., 2525 E. 93rd St., Cleveland, O.**

PERSONNEL: F. S. Wellman, Pres. & Treas.; H. G. Wellman, V. Pres. & Secy.; D. Smith, Gen. Mgr.; J. Duffield, Prod. Mgr.; H. Allchin, Sales Mgr.; J. Wellman, Pur. Dir.; H. Robertson, Pers. Dir.

**A. H. WELLS & CO., INC., Waterbury, Conn.**

PERSONNEL: F. A. Wells, Pres.; I. F. Schoonmaker, V. Pres.; C. H. Wells, Secy.; G. H. Wells, Treas.; L. K. Hartman, Sales Mgr.

**WELTRONIC CO.,**

3080 E. Outer Drive, Detroit, Mich.

PERSONNEL: F. Johnson, Pres.; C. J. Collom, V. Pres. & Gen. Mgr.; W. Martin, Secy. & Treas.; L. F. Stander, Sales Mgr.; J. Powers, Pur. Agt.; G. Undy, Chief Engr.

**R. D. WERNER CO., INC.,**

380 Second Ave., New York, N. Y.

PERSONNEL: R. D. Werner, Pres. & Gen. Mgr.; V. C. Petersen, V. Pres. & Sales Mgr.; L. Werner, Secy., Treas., Pur. Agt. & Pers. Dir.; L. Giblin, Pub. Dir.; A. Olsen, Chief Engr.

**WESLEY LACQUER CO.,**

95 Fourth St., Brooklyn, N. Y.

PERSONNEL: F. J. Wesley, Pres.

# Aircraft accessory equipment\*

*by the million!*

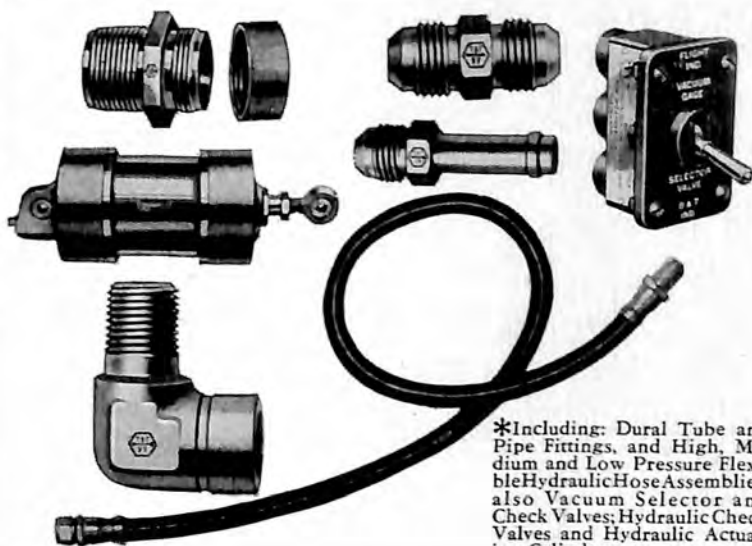

\*Including: Dural Tube and Pipe Fittings, and High, Medium and Low Pressure Flexible Hydraulic Hose Assemblies; also Vacuum Selector and Check Valves; Hydraulic Check Valves and Hydraulic Actuating Cylinders.

The Weatherhead Company's vast wartime production record is an indication of what the aviation industry can expect from us in the days of Peace. Every Weatherhead part has been engineered for maximum performance, speed of production and competitive pricing. They are made to "AN" specifications in regular accepted sizes as standard production.

*Look Ahead with* 

# Weatherhead

THE WEATHERHEAD COMPANY, CLEVELAND, OHIO

Branch Offices:

Detroit, Los Angeles, New York, St. Louis



**WESTERN AERONAUTICAL SUPPLY MANUFACTURING CO.,** 1729 Standard Ave., Glendale, Calif.

PERSONNEL: E. Boyer, Pres.; W. T. Boyer, V. Pres.; R. M. Brown, Secy.

**WESTERN AUTOMATIC MACHINE SCREW CO., AIRCRAFT PRODUCTS DIV.,** Lake Ave., Elyria, O.

PERSONNEL: B. C. Franklin, V. Pres. &amp; Gen. Mgr.; F. H. Byrant, Secy.; C. H. Smith, Treas.; R. D. Oldfield, Sales Mgr.; A. F. Steller, Pur. Agt.; R. D. Buol, Pers. Dir.; W. J. Cox, Pub. Dir.; R. A. Green, Chief Engr.

**WESTERN ELECTRIC CO., INC., RADIO DIV.,** 120 Broadway, New York, N. Y.

PERSONNEL: C. G. Stoll, Pres.; F. R. Lack, V. Pres.; N. R. Frame, Secy.; G. B. Proud, Treas.; H. N. Willets, Sales Mgr.; D. F. G. Eliot, Pur. Agt.; A. B. Goetze, Pers. Dir.; F. B. Wright, Pub. Dir.; H. W. Forster, Adv. Mgr.

**WESTERN INDUSTRIAL ENGINEERING CO.,** 3301 Medford St., Los Angeles, Calif.

PERSONNEL: M. B. Butler, Pres. &amp; Gen. Mgr.; N. B. Taylor, V. Pres.; C. H. Billingsley, Secy.; F. J. Butler, Treas.; L. J. Highfield, Sales Mgr.; A. Willenbring, Pur. Agt.; V. Schneider, Pers. Dir.; W. F. Jaynes, Chief Engr.

**WESTINGHOUSE ELECTRIC & MANUFACTURING CO.,** East Pittsburgh, Pa.

PERSONNEL: G. H. Bucher, Pres.; B. W. Clark, V. Pres.; C. B. Stainback, Sales Mgr.; G. E. Pendray, Adv. Mgr.

**WESTON ELECTRICAL INSTRUMENT CORP.,** 614 Frelinghuysen Ave., Newark, N. J.

PERSONNEL: E. F. Weston, Pres.; C. Brown, V. Pres. &amp; Secy.; E. R. Mellen, Treas.; R. R. Lambe, Gen. Mgr.; H. L. Gerstenberger, Sales Mgr.; A. R. Briggs, Pur. Agt.; S. Cassey, Pub. Dir.; W. N. Goodwin, Chief Engr.

**WHEELCO INSTRUMENTS CO.,**

847 W. Harrison St., Chicago, Ill.

PERSONNEL: L. W. Wheeler, Pres. &amp; Gen. Mgr.; R. A. Schoenfeld, V. Pres. &amp; Sales Mgr.; T. A. Cohen, V. Pres. &amp; Chief Engr.; G. A. Wheeler, Secy. &amp; Treas.; W. Flynn, Pur. Agt.; R. W. Murphy, Pers. Dir. &amp; Pub. Dir.

**WHEELER REFLECTOR CO.,**

275 Congress St., Boston, Mass.

PERSONNEL: G. J. Henry, Pres.; R. Burrage, Treas.; H. A. Barnes, Sales Mgr.; W. R. Jones, Pur. Agt.; J. S. Sessler, Pub. Dir.; K. A. Sawin, Chief Engr.

**DAVID WHITE CO.,**

315 W. Court St., Milwaukee, Wisc.

PERSONNEL: C. Rothweiler, Pres.; C. J. Otjen, V. Pres.; T. Salzer, Secy. &amp; Treas.; E. G. Lucke, Sales Mgr.; G. R. Flynn, Pur. Agt.

**THE S. S. WHITE DENTAL MFG. CO.,**

10 E. 40th St., New York, N. Y.

**WHITE RODGERS ELECTRIC CO.,**

1209 Cass Ave., St. Louis, Mo.

PERSONNEL: L. F. Blough, Pres.; J. A. Rodgers, V. Pres.-Engrg.; C. White, V. Pres. &amp; Pur. Dir.; M. A. Hellman, Secy.; L. G. Rowe, Treas.; T. W. Broesel, Adv. Mgr.

**WHITEHEAD STAMPING CO.,**

1661 W. Lafayette Blvd., Detroit, Mich.

PERSONNEL: J. F. Whitehead, Pres.; T. C. Whitehead, V. Pres.; G. W. Schreck, Secy.

**WHITING CORP.,**

157th St. &amp; Lathrop Ave., Harvey, Ill.

PERSONNEL: H. D. Grant, Pres.; S. H. Hammond, Exec. V. Pres.; H. W. Anderson, Aviation Div. Mgr.

**BAXTER D. WHITNEY & SON, INC.,**

Winchendon, Mass.

PERSONNEL: W. M. Whitney, Pres.; W. H. Morlock, V. Pres. &amp; Gen. Mgr.; K. O. Brown, Sales Mgr.; E. D. May, Chief Engr.

**THE WHITNEY CHAIN & MFG. CO.,**

237 Hamilton St., Hartford, Conn.

PERSONNEL: W. H. Whitney, Pres. &amp; Gen. Mgr.; L. B. Reed, V. Pres.; P. C. Boyd, Secy. &amp; Treas.; V. A. Hanson, Sales Mgr.; J. D. McGrath, Pur. Agt.; C. H. Sweet, Pers. Dir.; E. N. Bidwell, Pub. Dir.; W. H. C. Berg, Chief Engr.

**WHITNEY SCREW CORP.,** Nashua, N. H.

PERSONNEL: E. D. Sargent, Pres.; D. F. Jeffery, V. Pres.; A. L. Whitney, Treas. &amp; Gen. Mgr.; L. P. Whitney, Sales Mgr.

**WICHITA WIRE PRODUCTS CO.,**

624 E. Harry, Wichita, Kans.

PERSONNEL: D. E. Varner, Owner; G. W. Hauck, Pur. Agt.

**WICKES BROTHERS,** 515 N. Washington Ave., Saginaw, Mich.

PERSONNEL: H. R. Wickes, Pres. &amp; Gen. Mgr.; C. Bintz, V. Pres. &amp; Sales Mgr.; C. G. Morrell, Secy. &amp; Treas.; W. E. Moore, Pur. Dir.; C. S. Thorson, Pers. Dir.; G. A. Kendall, Adv. Mgr.; F. S. Floeter, Chief Engr.

**WICO ELECTRIC CO.,**

West Springfield, Mass.

PERSONNEL: E. L. Stoughton, Pres. &amp; Gen. Mgr.; K. A. Harmon, V. Pres.; H. P. Streeter, Secy.; H. J. Bock, Treas.; G. J. Lang, Sales Mgr.; A. L. Parker, Pur. Agt.; M. F. Allen, Pers. Dir.

**EDWIN L. WIEGAND CO.,**

7500 Thomas Blvd., Pittsburgh, Pa.

PERSONNEL: E. L. Wiegand, Pres. &amp; Gen. Mgr.; A. P. Wiegand, V. Pres.; M. M. Greer, Secy.; E. N. Calhoun, Treas. &amp; Sales Mgr.; R. D. Allshouse, Pur. Agt.; M. B. Holsopple, Pers. Dir.; D. A. Wolff, Pub. Dir.; J. McOrly, Chief Engr.

**E. W. WIGGINS AIRWAYS INC.,**

Norwood, Mass.

PERSONNEL: C. S. Cowan, Pres.; C. H. Scott, V. Pres. &amp; Prod. Mgr.; J. Garside, Secy. &amp; Chief Engr.; E. W. Wiggins, Treas. &amp; Gen. Mgr.; F. S. Tobey, Sales Mgr. &amp; Adv. Mgr.; H. E. Martin, Pur. Dir.

**WILBER & SON,**

545 Mission St., San Francisco, Calif.

PERSONNEL: B. M. Wilber, Pres.

**WILKENING MANUFACTURING CO.,**

2000 S. 71st St., Philadelphia, Pa.

PERSONNEL: F. W. Wilkening, Pres.; W. K. Lee, W. S. Loeb, V. Pres.; H. E. Gerstley, V. Pres. &amp; Treas.; C. Wilkening, Secy.; D. A. Cowhig, Gen. Mgr.; W. A. Clouser, Sales Mgr.; F. S. Cohen, Pur. Agt.; W. A. Kirkpatrick, Pub. Dir.; P. E. Friend, Chief Engr.

**THE WILBUR & WILLIAMS CO.,** Park Square Bldg., 33 St. James Ave., Boston, Mass.

PERSONNEL: M. E. Williams, Pres. &amp; Sales Mgr.; D. E. Wilbur, Treas. &amp; Gen. Mgr.; F. R. Farnham, Pub. Dir.

***From here to everywhere!***

**H**UB of tomorrow's world will be the airport — routes radiating from it to every quarter of the globe will be charted in the skies by radio.

For your new and finer post-war radio equipment, come to Western Electric—the nation's largest producer of electronic and communications equipment for war!

*Buy War Bonds regularly — from now till Victory!*

75<sup>th</sup> ANNIVERSARY

**Western Electric**

ARSENAL OF COMMUNICATIONS EQUIPMENT



**WILLIS & GEIGER, INC.,**

529 W. 42nd St., New York, N. Y.

PERSONNEL: B. W. Willis, Pres.; P. P. Geiger, V. Pres.; H. W. Geiger, Secy. &amp; Treas.

**WILLSON PRODUCTS, INC.,**

Second &amp; Washington Sts., Reading, Pa.

PERSONNEL: T. A. Willson, Pres., Gen. Mgr. &amp; Sales Mgr.; H. M. Hafer, V. Pres.; J. F. Clark, Secy.; F. S. Stump, Treas.; M. C. Rider, Pur. Agt.; H. W. Werner, Pers. Dir.; B. M. Leavy, Pub. Dir.; H. F. Shindel, Chief Engr.

**WILMINGTON FIBRE SPECIALTY CO.,**  
Wilmington, Del.

PERSONNEL: J. W. Morris, Pres.; F. L. Gerhauser, V. Pres.; A. O. Stehl, Secy.; M. L. K. Armstrong, Treas.; H. M. Romig, Sales Mgr.; J. R. Quinn, Pur. Agt.

**H. A. WILSON CO.,**

105 Chestnut St., Newark, N. J.

PERSONNEL: H. A. Wilson, Pres.; F. B. Fry, V. Pres.; F. O. Williams, Secy.; F. E. Matzenbacker, Asst. Treas. &amp; Pur. Agt.; L. Brock, Sales Mgr., Bi-metals; A. N. Rohr, Sales Mgr., Electrical Contacts.

**WIL-X-M'F'G. CORP.,**

29 Ryerson St., Brooklyn, N. Y.

PERSONNEL: E. A. Reynolds, Pres. &amp; Secy.; H. L. Gage, Exec. V. Pres.; R. L. Harrison, V. Pres.-Sales; G. A. Schwaninger, Treas.

**WINCHESTER REPEATING ARMS CO. DIV. OF WESTERN CARTRIDGE CO.,**  
275 Winchester Ave., New Haven, Conn.

PERSONNEL: F. W. Olin, Pres.; J. M. Olin, V. Pres.; S. T. Olin, Secy. &amp; Treas.; T. I. S. Boak, Works Mgr. &amp; Chief Engr.; R. Wier, Jr., Sales Mgr.; R. C. Swanton, Pur. Agt.; A. F. Snyder, Pers. Dir.; D. E. Whitelam, Pub. Dir.

**WINTER BROTHERS CO.,**

Kendrick St., Wrentham, Mass.

PERSONNEL: J. E. Winter, Pres.; M. Winter, V. Pres.; C. C. Winter, Secy. &amp; Chief Engr.; J. L. Cook, Treas., Gen. Mgr. &amp; Sales Mgr.; G. F. Gardner, Pur. Agt.; H. B. Stringer, Pers. Dir.

**WIPE-ON CORP.,**

105 Hudson St., New York, N. Y.

PERSONNEL: R. B. Anderson, Pres.; D. C. Anderson, V. Pres. &amp; Treas.; W. J. Anderson, Secy.; R. G. Dooling, Gen. Mgr.

**THE WIREMOLD CO.,**

Elmwood, P. O., Hartford, Conn.

PERSONNEL: D. H. Murphy, Pres.; J. D. Murphy, V. Pres.; W. D. Ball, Secy. &amp; Sales Mgr.; L. S. Zahronsky, Treas.; G. M. Armor, Pur. Agt.; A. O. LaDucer, Chief Engr.

**WITTEK MANUFACTURING CO.,**

4305-15 W. 24th Pl., Chicago, Ill.

PERSONNEL: B. A. Tetzlaff, Pres.; C. Tetzlaff, V. Pres., Gen. Mgr. &amp; Sales Mgr.; H. E. Forde, Pur. Agt.

**WOLF'S HEAD OIL REFINING CO.,**

Oil City, Pa.

PERSONNEL: E. W. Chase, Pres.; A. W. Scott, V. Pres., Secy. &amp; Gen. Mgr.; E. E. Bellen, Treas.; W. J. Scott, Pur. Agt.; B. H. Waterbury, Chief Engr.

**F. P. WOLL & CO.,**

Church &amp; Tacony Sts., Philadelphia, Pa.

**WOLVERINE TUBE DIV. OF CALUMET & HECLA CONSOLIDATED COPPER CO.,**  
1411 Central Ave., Detroit, Mich.

PERSONNEL: V. D. Hanna, Secy. &amp; Treas.; O. Z. Klopsch, Gen. Mgr.; R. F. Moody, Sales Supervisor; R. H. Gill, Pur. Agt.; D. D. Decker, Pers. Dir.; J. A. Marshall, Pub. Dir.; J. W. Andrews, Chief Engr.

**J. W. WOOD ELASTIC WEB CO.,**

Stoughton, Mass.

PERSONNEL: J. W. Wood, Pres.; P. Wood, V. Pres.; T. S. Walker, Secy.; K. A. Crimmins, Treas.; H. W. Denison, Gen. Mgr.

**WOODWARD GOVERNOR CO.,**

5001 N. Second St., Rockford, Ill.

PERSONNEL: I. C. Martin, Pres. &amp; Gen. Mgr.; H. W. Thorrell, V. Pres. &amp; Prod. Mgr.; R. W. Estell, V. Pres., Sales Mgr. &amp; Pub. Dir.; D. Sandell, Secy.; W. A. Ring, Treas. &amp; Pur. Dir.; F. Crawford, Pers. Dir.; W. J. Whitehead, Chief Engr.

**N. A. WOODWORTH CO.,** Sales Div., 1300 E. Nine Mile Rd., Detroit 20, Mich.

PERSONNEL: N. A. Woodworth, Pres.; V. A. Anderson, Secy. &amp; Treas.; E. W. LaMonte, Prod. Mgr.; R. E. Kramer, Sales Mgr.; E. P. Gallagher, Pur. Dir.; D. E. Wright, Pers. Dir.; A. R. Gloster, Pub. Dir.; R. E. Kramer, Adv. Mgr.

**WORCESTER PRESSED STEEL CO.,**

100 Barber Ave., Worcester, Mass.

PERSONNEL: J. W. Higgins, Pres. &amp; Treas.; A. P. Higgins, V. Pres. &amp; Secy.; T. P. Draper, V. Pres. &amp; Gen. Mgr.; C. C. Higgins, Sales Mgr. &amp; Pub. Dir.; C. C. Fletcher, Pur. Agt.; C. S. Holbrook, Pers. Dir.; W. Werme, Chief Engr.

**WORCESTER STAMPED METAL CO.,**

9 Hunt St., Worcester, Mass.

PERSONNEL: F. E. Billings, Pres. &amp; Treas.; C. F. Carlstrom, V. Pres. &amp; Gen. Mgr.; W. E. Billings, Secy. &amp; Pur. Agt.; S. P. Hull, Sales Mgr.

**WORCESTER TAPER PIN CO.,**

47 LaGrange St., Worcester, Mass.

PERSONNEL: F. J. Barry, Pres. &amp; Gen. Mgr.; E. Hirvonen, V. Pres. &amp; Chief Engr.; P. Sibley, Secy., Treas., Sales Mgr., Pur. Agt. &amp; Pub. Dir.; A. T. Warman, Pers. Dir.

**WORTHINGTON MOWER CO.,**

Stroudsburg, Pa.

PERSONNEL: E. R. Sawtelle, Pres. &amp; Sales Mgr.; J. I. Blair, V. Pres. &amp; Chief Engr.; C. R. Bensingler, Secy.; J. C. Rodewald, Treas.; W. U. Roulette, Jr., Pur. Agt.

**WROUGHT WASHER MFG. CO.,**

2100 South Bay St., Milwaukee, Wisc.

PERSONNEL: F. C. Doepke, Pres.; C. H. Disch, V. Pres. &amp; Pur. Agt.; W. F. Disch, Secy. &amp; Sales Mgr.; J. A. Holzer, Treas.; C. R. Dowdy, Chief Engr.

**WYANDOTTE CHEMICALS CORP.,** J. B. FORD, DIV., Wyandotte, Mich.

PERSONNEL: C. B. Robinson, V. Pres.-Sales; W. M. Cole, Sales Mgr., Ind. Dept.

**WYMAN-GORDON CO.,**

105 Madison St., Worcester, Mass.

PERSONNEL: H. G. Stoddard, Pres.; R. W. Stoddard, V. Pres.; C. C. Winn, Treas.; R. M. Powell, F. E. Wellington, Sales Mgrs.; C. A. Crabbe, H. Layport, Pur. Dir.; C. H. Beck, Pers. Dir.; J. H. Nelson, Chief Engr.

**Y****THE YALE & TOWNE MFG. CO.,**

200 Henry St., Stamford, Conn.

PERSONNEL: W. G. Carey, Jr., Pres.; J. A. Horne, V. Pres.; F. Dunning, Secy. &amp; Treas.; W. R. Hoyt, Gen. Mgr.; M. A. Miller, Sales Mgr.; A. B. Nordin, Jr., Pur. Agt.; J. Williams, Pers. Dir.

*The largest producer  
of aircraft forgings in  
the world.*

**WYMAN-GORDON**

**WORCESTER, MASS.**

**HARVEY, ILL.**

**DETROIT, MICH.**

**LIQUIDOMETER**

**TANK QUANTITY GAUGES**



Liquidometer Gauges are used on thousands of military, naval and commercial airplanes in service throughout the world. They provide positive, dependable and accurate knowledge of the quantity of fuel, oil, de-icer fluid, or other liquids contained in tanks.

**The Liquidometer Corp.**

37th Street and Skillman Ave.

Long Island City, N. Y.



**WITTEK**

*Aviation*

**HOSE CLAMPS**

For Leakproof  
Hose Connections

**WITTEK MANUFACTURING CO.**  
Chicago 23, Illinois

**THE YODER CO.,**  
5500 Walworth Ave., Cleveland, O.  
PERSONNEL: C. M. Yoder, Pres.; J. I. Lucas,  
V. Pres.; H. O. Yoder, Secy. & Treas.; N. C.  
Rubin, Sales Mgr.; C. A. Elicker, Pur. Agt.;  
L. Morgan, Pers. Dir.; A. F. Greene, Pub. Dir.;  
G. E. Kentis, Jr., Chief Engr.

**YOUNG RADIATOR CO.,**  
709 Marquette St., Racine, Wisc.  
PERSONNEL: F. M. Young, Pres.; J. J. Hilt, R.  
Grant, V. Pres.; W. H. Schleck, Secy. & Treas.;  
G. Haislmaier, Sales Mgr.; R. W. Baggott,  
Pur. Agt.; A. D. Lynch, Pers. Dir.; R. M. Snow,  
Pub. Dir.; W. V. Astrup, Chief Engr.; J. C.  
Shaw, Aircraft Products Engr.

## Z

**ZIEROLD METALS CO.,**  
224 W. Orange Grove, Burbank, Calif.  
PERSONNEL: H. A. Zierold, Owner; E. M.  
Zierold, Secy.; F. A. Demshaw, Pur. Agt.

**ZENITH CARBURETOR DIV., BENDIX  
AVIATION CORP.,** 696 Hart Ave.,  
Detroit, Mich.  
PERSONNEL: G. C. Fricke, Gen. Mgr.; R. C.  
Allan, Sales Mgr.; D. J. Martin, Pur. Agt.; R.  
W. Sloane, Asst. Chief Engr.

## DEALERS, DISTRIBUTORS, EXPORTERS AND SHIPPERS

**EDWIN D. ALLMENDINGER,**  
15 Moore St., New York, N. Y.  
**AIRCRAFT EXPORT CORP.,**  
30 Rockefeller Plaza, New York, N. Y.  
**AMERICAN EASTERN CORP.,**  
30 Rockefeller Plaza, New York, N. Y.  
**AVIATION EQUIPMENT & EXPORT, INC.,**  
25 Beaver St., New York, N. Y.  
**AVIQUIPO, INC.,**  
25 Beaver St., New York, N. Y.  
**CHARLES H. BARB CO.,**  
Grand Central Air Terminal, Glendale,  
Calif.  
**BAKER STEEL & TUBE CO.,**  
955 S. Alameda St., Los Angeles, Calif.  
**BARR SHIPPING CORP.,**  
25 Broadway, New York, N. Y.  
**BENDIX EXPORT DIV. OF BENDIX AVIA-  
TION CORP.,** 30 Rockefeller Plaza,  
New York, N. Y.  
**BLUEFRIES-NEW YORK, INC.,**  
44 Whitehall St., New York, N. Y.  
**CALIFORNIA PANEL & VENEER CO.,**  
955 Alameda St., Los Angeles, Calif.  
**CAMPBELL HARDWARE & SUPPLY CO.,**  
108 First Ave., S., Seattle, Wash.  
**CHINA AIRMOTIVE CO.,**  
444 Madison Ave., New York, N. Y.

**CURTISS EXPORTS DIV. OF CURTISS-  
WRIGHT CORP.,** 30 Rockefeller Plaza,  
New York, N. Y.  
**GILLIES AVIATION CORP.,**  
Bethpage, N. Y.  
**J. V. W. CORPORATION,**  
1100 Raymond Blvd., Newark, N. J.  
**MIRANDA BROTHERS, INC.,**  
6 E. 45th St., New York, N. Y.  
**NORTHWEST AIR SERVICE, INC.,**  
Boeing Field, Seattle, Wash.  
**ROYAL SHIPPING CO.,**  
21 Pearl St., New York, N. Y.  
**STANDARD AIRCRAFT EQUIPMENT CO.,**  
Roosevelt Field, Mineola, N. Y.  
**TRI-AMERICAN AIRCRAFT CORP.,**  
Graybar Bldg., New York, N. Y.  
**UNITED AIRCRAFT EXPORT DIV. OF  
UNITED AIRCRAFT CORP.,** E. Hart-  
ford, Conn.  
**THE VIMALERT CO., LTD.,**  
807 Garfield Ave., Jersey City, N. J.

Cable Address—"Bluefries" New York  
Telephones—Bowling Green 9-6395

## BLUEFRIES-NEW YORK, Inc.

INTERNATIONAL SHIPPING AGENTS

**44 WHITEHALL STREET  
NEW YORK**

Specializing in Preparing, Boxing,  
Processing of Airplanes and Spare  
Parts for Shipment Overseas.

*Our Activities Include:*  
**EXPORT-IMPORT SHIPPING  
CUSTOMS BROKERAGE  
SUPERINTENDENCE  
WEIGHING  
SURVEYING  
SAMPLING**

Packing · Distribution and Splitting  
of Carloads · Trucking

Combined Freight Service  
to Various Countries

**COUSE MOBILE SHOPS AND EQUIPMENT**

**1. TYPE "A" WELDING SHOP**

Illustrated here. This Shop contains all equipment needed for light and heavy spot repairs including: 8-ton lifting crane, 10-ton hydraulic floor jack with base, 100-ton hydraulic press, sockets from midget to 2½", complete general tools. The truck provides both oxy-acetylene and electric arc welding, the 300 amp. D.C. welder operating either from city lines or truck engine. The truck also supplies 10 K.W. A.C. electric power in the field.



draulic press, valve grinder and reseater, heavy duty lathe, milling, grinding, and keyseating converter, complete chucking and tool equipment, precision machinists' tools, taps, dies, drills and reamers.

*"Take the Shop to the Work"*

**2. TYPE "B" MACHINE SHOP**

Does all work requiring machining. The truck includes: 3-ton pry boom, radial air drill press, compressor, electric generator, complete air and electric tools, 10-ton hy-

**COUSE LABORATORIES, 300 Passaic Street, Newark, N. J.**

**AIRCRAFT AND MARINE  
SPECIALTY COMPANY**

302 South Central Avenue  
Baltimore, 2, Maryland

As sub-contractors for the leading aircraft manufacturers we are producing engine and surface control components, tapered aluminum shims, fillers, indicator lights, fittings, and a variety of miscellaneous mechanisms. We solicit your inquiries for engineering and development work, as well as your production requirements.

**J. RAMSEY SPEER, JR., President.**



## AERONAUTICAL CHAMBER OF COMMERCE OF AMERICA, INC.

Shoreham Building, Washington, D. C.

### Officers

Chairman of the Board, E. E. Wilson ..... President, United Aircraft Corp.  
 Vice Chairman of the Board, Donald W. Douglas ..... President, Douglas Aircraft Co., Inc.  
 President, James P. Murray ..... Vice President, Boeing Aircraft Co.  
 Vice President, Lawrence D. Bell ..... President, Bell Aircraft Corp.  
 Vice President, LaMotte T. Cohn ..... President, Northrop Aircraft, Inc.  
 Secretary, Harrison Brand, Jr. .... Aeronautical Chamber of Commerce of America, Inc.  
 Treasurer, John E. P. Morgan ..... Aeronautical Chamber of Commerce of America, Inc.

### Governors

E. R. Breech\* ..... Bendix Aviation Corp.  
 Clayton J. Brukner ..... The Waco Aircraft Co.  
 Donald W. Douglas\* ..... Douglas Aircraft Co., Inc.  
 Victor Emanuel ..... The Aviation Corp.  
 R. E. Gilmor ..... Sperry Gyroscope Co.  
 Robert E. Gross ..... Lockheed Aircraft Corp.  
 P. G. Johnson\* ..... Boeing Aircraft Co.  
 J. H. Kindelberger ..... North American Aviation, Inc.  
 Alfred Marchev ..... Republic Aviation Corp.  
 Glenn L. Martin\* ..... The Glenn L. Martin Co.  
 T. Claude Ryan ..... Ryan Aeronautical Corp.  
 Guy W. Vaughan ..... Curtiss-Wright Corp.  
 J. Carlton Ward, Jr. .... Fairchild Engine & Airplane Corp.  
 E. E. Wilson\* ..... United Aircraft Corp.  
 Harry Woodhead ..... Consolidated Vultee Aircraft Corp.

\* Executive Committee

### Staff of the Chamber

General Manager ..... Harrison Brand, Jr.  
 Manager, Technical Department ..... Eugene W. Norris  
 Engine Technical Expert ..... J. H. Sidebottom  
 Airplane Technical Expert ..... Ivar C. Peterson  
 Manager, Traffic Department ..... Harry R. Brashear  
 Manager, Information Department ..... Paul R. Price  
 Manager, Economic Development Department ..... John Howard Payne  
 Manager, Personal Aircraft Department ..... John E. P. Morgan  
 Manager, Legislative Department ..... Halford G. Davis  
 Manager, Research & Statistics Department ..... E. E. Lothrop  
 Manager, Industrial Relations Research Department ..... R. Randall Irwin

## AIR TRANSPORT ASSOCIATION OF AMERICA

1515 Massachusetts Ave., N. W.

Washington 5, D. C.

### Officers

President ..... Edgar S. Gorrell  
 Vice President ..... Croil Hunter  
 Secretary ..... M. F. Redfern  
 Treasurer ..... J. F. Hintersehr

### Directors

|                  |                 |                    |
|------------------|-----------------|--------------------|
| T. E. Braniff    | Jack Frye       | W. A. Patterson    |
| T. C. Drinkwater | C. Bedell Monro | E. V. Rickenbacker |
|                  | O. M. Mosier    |                    |



## Hammering the *Herrenvolk*

The planes that fly from Britain by night, supplemented by daylight raids, have been softening Germany by increasingly heavier blows at her vitals, making it more difficult for the Nazis to supply their fronts.

No small part in the superiority of today's American planes is being played by tough, drop forged parts, several hundred of which are used in a single bomber. At Kropp Forge Aviation, we rejoice in the volume of forgings which we are turning out for wing, strut, fuselage, engine, landing gear, linkage mechanism and bomb release parts; rugged, stress resistant parts delivered on time.



Member of the A.C.C.A.

**K** *Kropp Forge Aviation Co.*  
 5301 W. ROOSEVELT ROAD CHICAGO  
 Engineering Representatives in Principal Cities

## MANUFACTURERS AIRCRAFT ASSOCIATION, INC.

30 Rockefeller Plaza, New York

## Officers

1944

|                         |                                                |
|-------------------------|------------------------------------------------|
| S. S. Bradley.....      | Chairman of the Board                          |
| F. H. Russell.....      | President                                      |
| Clayton J. Brukner..... | Vice President                                 |
| Robert E. Gross.....    | Vice President                                 |
| Joseph T. Hartson.....  | Vice President                                 |
| J. H. Kindelberger..... | Vice President                                 |
| Raymond S. Pruitt.....  | Vice President                                 |
| John M. Rogers.....     | Vice President                                 |
| Raycroft Walsh.....     | Vice President                                 |
| James P. Murray.....    | Secretary                                      |
| William E. Valk.....    | Treasurer                                      |
| John A. Sanborn.....    | Asst. Treas., Asst. Secy., and General Manager |

## Directors

|                           |                                          |
|---------------------------|------------------------------------------|
| S. S. Bradley.....        | Chairman of the Board                    |
| A. T. Burton.....         | North American Aviation, Inc.            |
| Charles H. Chatfield..... | United Aircraft Corporation              |
| Frank N. Fleming.....     | Douglas Aircraft Company, Inc.           |
| G. Sumner Ireland.....    | Lockheed Aircraft Corporation            |
| George D. Jones.....      | The Glenn L. Martin Company              |
| Charles Kingsley.....     | Grumman Aircraft Engineering Corporation |
| James P. Murray.....      | Boeing Aircraft Company                  |
| R. S. Pruitt.....         | Consolidated Vultee Aircraft Corporation |
| Frank H. Russell.....     | President                                |
| William E. Valk.....      | Curtiss-Wright Corporation               |
| Ray P. Whitman.....       | Bell Aircraft Corporation                |

## NATIONAL AERONAUTIC ASSOCIATION OF U. S. A., INC.

(Founded 1922)

1025 Connecticut Avenue, Washington 6, D. C.

United States Representative of Federation Aeronautique Internationale  
Governing Body for Sporting Aviation in the United States

## Officers

|                      |                            |
|----------------------|----------------------------|
| President.....       | William R. Enyart          |
| Vice President.....  | Harry K. Coffey            |
| Vice President.....  | Glenn B. Eastburn          |
| Vice President.....  | James R. Graham            |
| Treasurer.....       | William P. Redding         |
| Secretary.....       | Richard C. Palmer          |
| General Counsel..... | William P. MacCracken, Jr. |
| Manager.....         | Lowell H. Swenson          |

## Board of Directors

|                   |                   |                         |
|-------------------|-------------------|-------------------------|
| J. Lee Barrett    | Roger Wolfe Kahn  | Laurance S. Rockefeller |
| Harry A. Bruno    | Wesley E. Keller  | William B. Stout        |
| Raymond E. Buck   | George B. Logan   | C. C. Thompson          |
| Dudley H. Dorr    | W. Percy McDonald | Roscoe Turner           |
| Stanley C. Draper | C. R. Mooney      | Stanley T. Wallbank     |
| Arthur S. Dudley  | H. W. Morrison    | O. S. Warden            |
| Carl Hinton       | Rudy C. Mueller   | J. Howard Wilcox        |
| John H. Jouett    | Wayne W. Parrish  | Gill Robb Wilson        |

*FAMOUS FORERUNNERS OF  
WINGED VICTORY  
OVER BERLIN, ROME AND TOKYO*



**B**ELLANCA planes gave the three Axis centers a preview of American air prowess many years before Hitler made the fatal mistake of starting this global war.

It was a Bellanca cabin monoplane that Chamberlin flew non-stop in 1927 from New York to Germany. It was a Bellanca that Williams and Yancey piloted in 1929 to Rome. And it was a Bellanca that Pangborn and Herndon guided over the Pacific on their sensational Tokyo flight of 1931.

These famous forerunners of winged victory blazed world sky trails which U. S. Army Air Forces are traveling with more and more powerful blows at our savage enemies.

Many other Bellanca transoceanic flights pioneered international air routes. And today Bellanca engineers contribute to Victory with their precision-built armament, warplane components and the AT-21-BL gunnery crew trainer. They're planning, too, for your peacetime plane!

**BELLANCA** AIRCRAFT CORPORATION  
NEW CASTLE, DELAWARE

## SOCIETY OF AUTOMOTIVE ENGINEERS, INC.

20 West 30th St., New York 18, New York

## Officers for 1944

|                                                   |                   |
|---------------------------------------------------|-------------------|
| President.....                                    | W. S. James       |
| Vice President (Rep. Aircraft Engrg.).....        | R. D. Kelly       |
| Vice President (Rep. Aircraft-Engine Engrg.)..... | A. T. Gregory     |
| Secretary and General Manager.....                | John A. C. Warner |

## The Council

|                                  |                                         |
|----------------------------------|-----------------------------------------|
| A. J. Blackwood, Vice President  | Arthur Nutt, Councilor                  |
| J. R. Sabina, Vice President     | N. P. Petersen, Councilor               |
| Earl H. Smith, Vice President    | C. G. A. Rosen, Councilor               |
| E. C. DeSmet, Vice President     | L. R. Buckendale, Councilor             |
| J. E. Hacker, Vice President     | R. F. Steeneck, Councilor               |
| O. R. Schoenrock, Vice President | H. T. Youngren, Councilor               |
| E. W. Templin, Vice President    | B. B. Bachman, Treasurer                |
| E. M. Schultheis, Vice President | A. W. Herrington, Past President (1942) |
|                                  | Mac Short, Past President (1943)        |

## Aeronautic Committees

|                                                              |                              |
|--------------------------------------------------------------|------------------------------|
| Aircraft Activity Committee.....                             | R. D. Kelly, Chairman        |
| Aircraft-Engine Activity Committee.....                      | A. T. Gregory, Chairman      |
| Air Transport Activity Committee.....                        | William Littlewood, Chairman |
| Standards Committee                                          |                              |
| Aeronautics Division.....                                    | Arthur Nutt, Chairman        |
| Aircraft-Engine Subdivision.....                             | C. E. Mines, Chairman        |
| Aircraft Access. & Equip. Subdivision.....                   | William Littlewood, Chairman |
| Aircraft-Engine Propeller Subdivision.....                   | Erle Martin, Chairman        |
| Aircraft Materials & Processes Coordinating Subdivision..... | J. B. Johnson, Chairman      |
| Aircraft-Engine Materials & Processes Committee.....         | B. Clements, Chairman        |
| Airframes Materials & Processes Committee.....               | L. D. Bonham, Chairman       |
| Aircraft Accessory Materials & Processes Committee.....      | N. E. Woldman, Chairman      |

## INSTITUTE OF THE AERONAUTICAL SCIENCES

1505 RCA Building, West, 30 Rockefeller Plaza

New York 20, New York

## Officers for 1944

|                                 |                      |
|---------------------------------|----------------------|
| President.....                  | R. H. Fleet          |
| Vice President.....             | Wellwood E. Beall    |
| Vice President.....             | William K. Ebel      |
| Vice President.....             | Elmer A. Sperry, Jr. |
| Vice President.....             | G. M. Williams       |
| Executive Vice President.....   | Bennett H. Horchler  |
| Treasurer.....                  | Charles H. Colvin    |
| Chairman of the Council.....    | Lester D. Gardner    |
| Assistant to the President..... | George R. Forman     |
| Secretary.....                  | Robert R. Dexter     |
| Controller.....                 | Joseph J. Maitan     |

## Council Members for 1944

|                    |                  |                 |
|--------------------|------------------|-----------------|
| P. R. Bassett      | C. S. Jones      | Alfred Marchev  |
| W. A. M. Burden    | Roger Wolfe Kahn | Ralph S. Damon  |
| R. T. Goodwin      | John C. Leslie   | Charles Froesch |
| R. Paul Harrington | Robb C. Oertel   | Earl D. Osborn  |

**"NORMA-HOFFMANN"**

**PRECISION BEARINGS**

BALL, ROLLER AND THRUST

Norma-Hoffmann is devoting all its resources and its 33 years' experience to the production of Precision Bearings for Army, Navy and Air Corps units.



NORMA-HOFFMANN BEARINGS CORP'N., STAMFORD, CONN., U. S. A.—FOUNDED 1911

**UNFAILING SECURITY!**

**DOUBLE LOCKING**

**PALNUTS**

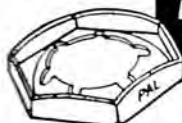

The PALNUT is a single thread, spring tempered locknut, which provides a powerful Double Locking action in very small space. When tightened, its arched slotted jaws grip the bolt like a chuck (B-B) while spring tension is exerted upward on the bolt thread and downward on the regular nut (A-A), securely locking both. PALNUTS are standard on leading aircraft engines and accessories.

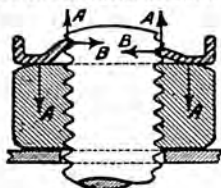

● Write for Palnut Manual No. 1

**THE PALNUT COMPANY**  
67 Cordier St., Irvington 11, N. J.

*Research  
and/or  
Production*



New booklet, \*When the Shooting Stops, locates **ENGINEERING INGENUITY** (available now) to help with new products and methods, machines, tools and dies to make them. It highlights our facilities (available after Victory) for experimental or mass production on contract of parts or products.

\*If you are an industrial executive, write me **TO-DAY** for a copy of this booklet. Joseph J. Cheney, President.

**WE OFFER  
INGENUITY  
After Victory**

**Spriesch** EST. 1923  
**TOOL & MANUFACTURING CO., Inc.**  
24 HOWARD ST. AD No 27-A BUFFALO 6, N. Y.



## U. S. ARMY AIR FORCES, WAR DEPARTMENT

Washington, D. C.

Henry L. Stimson, Secretary of War  
 Robert W. Patterson, Under Secretary of War  
 Robert A. Lovett, Asst. Secretary of War for Air

## Army Air Forces

March 1, 1944

|                                                                                |                                                                               |
|--------------------------------------------------------------------------------|-------------------------------------------------------------------------------|
| Commanding General, Army Air Forces.....                                       | General Henry H. Arnold                                                       |
| Chief of Air Staff.....                                                        | Major General Barney H. Giles                                                 |
| Deputy Chief of Air Staff.....                                                 | Brigadier General H. S. Vandenberg                                            |
| Deputy Chief of Air Staff.....                                                 | Brigadier General E. S. Perrin                                                |
| Deputy Chief of Air Staff.....                                                 | Brigadier General William E. Hall                                             |
| Assistant Chief of Air Staff, Personnel.....                                   | Major General J. H. Revans                                                    |
| Assistant Chief of Air Staff, Intelligence.....                                | Brigadier General Thomas D. White                                             |
| Assistant Chief of Air Staff, Training.....                                    | Major General R. W. Harper                                                    |
| Assistant Chief of Air Staff, Material, Maintenance and<br>Distribution.....   | Major General Oliver P. Echols                                                |
| Assistant Chief of Air Staff, Operations, Commitments and<br>Requirements..... | Brigadier General H. A. Craig                                                 |
| Assistant Chief of Air Staff, Plans.....                                       | Major General L. S. Kuter                                                     |
| Training Command.....                                                          | Lieutenant General Barton K. Yount<br>Texas & Pacific Bldg., Ft. Worth, Texas |
| Air Service Command.....                                                       | Major General W. H. Frank<br>Patterson Field, Ohio                            |
| Air Transport Command.....                                                     | Major General H. L. George<br>Gravelly Point, Washington, D. C.               |
| Material Command.....                                                          | Major General C. E. Branshaw<br>Wright Field, Dayton, Ohio                    |
| AAF Tactical Center.....                                                       | Brigadier General Hume Peabody<br>Orlando, Florida                            |
| Proving Ground Command.....                                                    | Brigadier General Grandison Gardner<br>Eglin Field, Florida                   |
| I Troop Carrier Command.....                                                   | Brigadier General F. W. Evans<br>Stout Field, Indianapolis, Ind.              |
| AAF Redistribution Center.....                                                 | Colonel Henry Bailey                                                          |
| Management Control.....                                                        | Brigadier General B. E. Gates                                                 |
| Office of Flying Safety.....                                                   | Colonel George C. Price<br>Winston-Salem, N. C.                               |
| Air Inspector.....                                                             | Brigadier General J. W. Jones                                                 |
| Air Surgeon.....                                                               | Major General D. N. W. Grant                                                  |
| Budget and Fiscal.....                                                         | Brigadier General L. W. Miller                                                |
| Air Judge Advocate.....                                                        | Brigadier General L. H. Hedrick                                               |
| Air Communications Office.....                                                 | Brigadier General H. H. McClelland                                            |
| Special Assistant for Anti-Aircraft.....                                       | Major General H. R. Oldfield                                                  |

## AVIATION WRITERS ASSOCIATION

P. O. Box 856, Grand Central Annex, New York 17, N. Y.

## Officers

|                            |                    |
|----------------------------|--------------------|
| President.....             | Wayne W. Parrish   |
| First Vice President.....  | George E. Haddaway |
| Second Vice President..... | Phillip Andrews    |
| Executive Secretary.....   | Devon Francis      |
| Treasurer.....             | Leslie V. Spencer  |



# UMBRELLA

Republic P-47 Thunderbolts were designed to put an umbrella over our bombers. They're fast, heavily armed...and of great importance, *they fly high!*

Fighting six to seven miles up, these Thunderbolts are testing out the air transport routes of tomorrow. Because the stratosphere is ideal for long distance transport planes...above cloud and weather and where the thin air means *speed*.

Thus, the work of the men and women of Republic who designed and built the Thunderbolt to operate best in the stratosphere represents a substantial contribution not only to aviation at war but also to aviation at peace. Republic Aviation Corporation, Farmingdale, L. I., New York, and Evansville, Indiana.

## REPUBLIC AVIATION

CORPORATION

SPECIALISTS IN HIGH-SPEED  
...HIGH ALTITUDE AIRCRAFT

MAKERS OF THE



FARMINGDALE DIVISION

# Thunderbolt

# DIRECTORY

## U. S. NAVAL AVIATION

Washington, D. C.

January 1, 1944

Frank Knox, Secretary of the Navy  
James V. Forrestal, Under Secretary of the Navy  
Artemus L. Gates, Assistant Secretary of the Navy for Air  
Ralph A. Bard, Assistant Secretary of the Navy

|                                   |                                                              |
|-----------------------------------|--------------------------------------------------------------|
| Adm. E. J. King.....              | Commander-in-Chief U. S. Fleet and Chief of Naval Operations |
| Vice Adm. J. S. McCain.....       | Deputy Chief of Naval Operations (Air)                       |
| Vice Adm. J. H. Towers.....       | Commander, Air Force Pacific Fleet                           |
| Vice Adm. P. N. L. Bellinger..... | Commander, Air Force Atlantic Fleet                          |
| Brig. Gen. L. E. Woods.....       | Director, Marine Aviation                                    |
| Capt. D. F. Smith.....            | Director, Naval Air Transport Service                        |
| Rear Adm. F. D. Wagner.....       | Asst. Deputy Chief of Naval Operations (Air)                 |
| Capt. S. C. Ring.....             | Director, Aviation Training                                  |
| Comdr. G. T. Mundorff.....        | Director, Air Information                                    |
| Capt. C. W. Wieber.....           | Director, Aviation Planning                                  |
| Capt. R. F. Hickey.....           | Director, Aviation Personnel                                 |
| Capt. J. W. Harris.....           | Director, Flight                                             |

### Bureau of Aeronautics\*

|                                 |                                    |
|---------------------------------|------------------------------------|
| Rear Adm. D. C. Ramsey.....     | Chief, Bureau of Aeronautics       |
| Rear Adm. L. B. Richardson..... | Asst. Chief, Bureau of Aeronautics |
| Comdr. J. S. Russell.....       | Director, Military Requirements    |
| Capt. L. S. Pope.....           | Director, Photographic             |
| Capt. L. DeFlorez.....          | Director, Special Devices          |
| Capt. A. C. Miles.....          | Director, Procurement              |
| Capt. H. R. Oster.....          | Director, Engineering              |
| Capt. D. Royce.....             | Director, Production               |

\* The Bureau of Aeronautics is responsible for the design and procurement of Naval aircraft. The aircraft then are turned over to the Office of the Deputy Chief of Naval Operations (Air).

### POST OFFICE DEPARTMENT AIR MAIL SERVICE

Washington, D. C.

|                                          |                 |
|------------------------------------------|-----------------|
| Postmaster General.....                  | Frank C. Walker |
| Second Assistant Postmaster General..... | Smith W. Purdum |

#### Domestic Air Mail Service:

|                                                     |                  |
|-----------------------------------------------------|------------------|
| Superintendent.....                                 | Roy M. Martin    |
| Assistant Superintendent.....                       | Vacant           |
| Assistant Superintendent, New York, N. Y.....       | W. H. Nichols    |
| Assistant Superintendent, Chicago, Ill.....         | R. E. Pollard    |
| Assistant Superintendent, Atlanta, Ga.....          | R. S. Burgess    |
| Assistant Superintendent, Fort Worth, Tex.....      | A. C. Hodges     |
| Assistant Superintendent, San Francisco, Calif..... | A. O. Willoughby |

Director of International Postal Service..... George H. Grayson



DESIGNED AND MANUFACTURED BY



**GRUMMAN**

AIRCRAFT ENGINEERING CORPORATION  
BETHPAGE LONG ISLAND NEW YORK

### NATIONAL ADVISORY COMMITTEE FOR AERONAUTICS

1500 New Hampshire Avenue, N. W., Washington, D. C.

Laboratories, Langley Field, Va.; Moffett Field, Calif.; Cleveland, O.

Created by act of Congress approved March 3, 1915, for the supervision and direction of the scientific study of the problems of flight. Its membership was increased to 15 by act approved March 2, 1939. The members are appointed by the President, and serve as such without compensation.

|                                                                                                               |                                                                                                            |
|---------------------------------------------------------------------------------------------------------------|------------------------------------------------------------------------------------------------------------|
| Jerome C. Hunsaker, Sc.D., (Chairman),<br>Massachusetts Institute of Technology,<br>Cambridge, Massachusetts. | Oliver P. Echols, Major General, Asst. Chief<br>of Air Staff, Army Air Forces.                             |
| Lyman J. Briggs, Ph.D., (Vice Chairman),<br>Director, National Bureau of Standards.                           | William A. M. Burden, Special Assistant to<br>the Secretary of Commerce.                                   |
| Charles G. Abbott, Sc.D., Secretary, Smith-<br>sonian Institution.                                            | Ernest M. Pace, Rear Admiral, Bureau of<br>Aeronautics, Navy Department.                                   |
| Henry H. Arnold, General, Commanding<br>General, Army Air Forces.                                             | Francis W. Reichelderfer, Sc.D., Chief, U. S.<br>Weather Bureau.                                           |
| Vannevar Bush, Sc.D., U. S. Office of Scien-<br>tific Research and Development, Washing-<br>ton, D. C.        | John S. McCain, Vice Admiral, Deputy Chief<br>of Naval Operations (Air), Navy Depart-<br>ment.             |
| William F. Durand, Ph.D., Stanford Univer-<br>sity, California.                                               | Edward Warner, Sc.D., Civil Aeronautics<br>Board.                                                          |
| William Littlewood, Vice-Pres., American<br>Airlines, New York.                                               | Orville Wright, Sc.D., Dayton, Ohio.                                                                       |
|                                                                                                               | Theodore P. Wright, Sc.D., Director, Aircraft<br>Resources Control Office, Aircraft Produc-<br>tion Board. |

---

George W. Lewis, Sc.D., Director of Aeronautical Research.

John F. Victory, LL.M., Secretary.

Edward H. Chamberlin, Assistant Secretary.

Henry J. E. Reid, Engineer-in-Charge, Langley Memorial Aeronautical Laboratory, Langley  
Field, Virginia.

Smith J. DeFrance, Engineer-in-Charge, Ames Aeronautical Laboratory, Moffett Field,  
California.

Edward R. Sharp, Administrative Officer, Aircraft Engine Research Laboratory, Cleveland,  
Ohio.

Carlton Kemper, Exec. Engineer, Aircraft Engine Research Laboratory, Cleveland, Ohio.

### FEDERAL COMMUNICATIONS COMMISSION

Washington, D. C.

#### Commissioners

|                              |                  |
|------------------------------|------------------|
| James Lawrence Fly, Chairman |                  |
| Paul A. Walker               | T. A. M. Craven  |
| Norman S. Case               | Ray C. Wakefield |
| C. J. Durr                   |                  |



A COMPLETE SERVICE  
**DESIGN-TEST EQUIPMENT • CONSTRUCTION**

**INDUSTRIAL SOUND CONTROL**  
*omestead*

HARTFORD, CONN.

CHICAGO, ILLINOIS

*~ ~ ~ ~ ~*  
**Airionics**

FOR PRACTICAL  
 ELECTRONIC SERVICE

Noah Webster, had he known the word, might have defined it:

**AIRIONICS** (ar ee on' iks) n. 1. A service in electronics. The development of electronic principles for the common good, combining science, engineering, human interest, friendly collaboration and business integrity. The electronic sciences applied to communications, navigation aids, or other devices necessary to the safety of aircraft, ships at sea, ground transportation and industry. An entity of practical electrical science and engineering facilities to produce a useful device.



**ALADDIN**

called on his Genie, you can call on AIRIONICS.

Send us your problem.

AIRIONICS may be the answer.

**HARVEY-WELLS**  
*Communications*  
 INCORPORATED

PLANNING FOR TOMORROW—TODAY

SOUTHBRIDGE, MASS.



**U. S. DEPARTMENT OF COMMERCE  
WEATHER BUREAU**

Washington, D. C.

|                                                     |                     |
|-----------------------------------------------------|---------------------|
| Chief of Bureau .....                               | F. W. Reichelderfer |
| Executive Assistant for Scientific Services.....    | C. F. Sarle         |
| Special Assistant for Technical Services.....       | D. M. Little        |
| Chief, Instrument Division .....                    | Wm. R. Thickstun    |
| Chief, Synoptic Reports and Forecasts Division..... | I. R. Tannehill     |
| Acting Chief, Station Operations Division.....      | R. E. Spencer       |

**Regional Directors**

|             |                                    |                 |
|-------------|------------------------------------|-----------------|
| Region I    | Flushing, N. Y.....                | Walter J. Moxom |
| Region II   | Atlanta, Ga.....                   | Merrill Bernard |
| Region III  | Chicago, Ill.....                  | Vincent E. Jakl |
| Region IV   | Fort Worth, Tex.....               | Erle L. Hardy   |
| Region V    | Kansas City, Mo.....               | John A. Riley   |
| Region VI   | Los Angeles, Calif.....            | Floyd D. Young  |
| Region VII  | Seattle, Wash. (Boeing Field)..... | J. C. Smith     |
| Region VIII | Anchorage, Alaska.....             | Glen Jefferson  |

**Forecast Centers**

*Airway Forecasts*

|                    |                    |
|--------------------|--------------------|
| Albuquerque, N. M. | Minneapolis, Minn. |
| Brownsville, Tex.  | New York, N. Y.    |
| Cincinnati, Ohio   | St. Louis, Mo.     |
| Dayton, Ohio       | Seattle, Wash.     |
| Fort Worth, Tex.   | Waco, Tex.         |
| Madison, Wisc.     |                    |

*Airway and General Weather Forecasts*

|                   |                       |
|-------------------|-----------------------|
| Anchorage, Alaska | Honolulu, T. H.       |
| Atlanta, Ga.      | Juneau, Alaska        |
| Billings, Mont.   | Kansas City, Mo.      |
| Boston, Mass.     | Miami, Fla.           |
| Burbank, Calif.   | New Orleans, La.      |
| Chicago, Ill.     | Salt Lake City, Utah  |
| Denver, Colo.     | San Francisco, Calif. |
| Fairbanks, Alaska | Washington, D. C.     |

*Hurricane Forecasts*

|               |                   |
|---------------|-------------------|
| Atlanta, Ga.  | New Orleans, La.  |
| Boston, Mass. | San Juan, P. R.   |
| Miami, Fla.   | Washington, D. C. |

**AIRCRAFT OWNERS AND PILOTS ASSOCIATION**

|                               |                                        |
|-------------------------------|----------------------------------------|
| National Service Office ..... | Carpenters Building, Washington, D. C. |
| President.....                | C. Townsend Ludington                  |
| Vice President.....           | Philip T. Sharples                     |
| Secretary.....                | Alfred L. Wolf                         |
| Treasurer.....                | Laurence P. Sharples                   |



Established 1931



**AIRCRAFT OIL  
DRAINCOCKS  
- VALVES and  
SOLENOIDS .**

(For Fuel - Oil -  
Hydraulic)

Specified as standard equipment on America's most renowned fighters and bombers . . . the highest tribute that could be paid to the outstanding superiority of Koehler Aircraft valves and solenoids. The culmination of 13 years experience in building similar products, Koehler oil valves are proving their worth where results count most.

**KOEHLER'S Newest Development OIL DRAIN COCKS**  
Poppet type; need no locking. Just two positions—open and closed. Operate freely and efficiently in temperatures to 65 degrees below zero to 160 degrees F. Furnished with or without thermometer wells. Your inquiries invited.

**KOEHLER AIRCRAFT PRODUCTS COMPANY**  
814 Vermont Ave., Dayton 4, Ohio

Producers of Aircraft (Oil and Fuel) Valves since 1931  
West Coast Representative: Western Aircraft Supply Co.  
Los Angeles, Calif.



**NEWEST TYPE  
K-1610B OIL  
COOLER DRAIN  
VALVE** Poppet Prin-  
ciple Weighs Only  
6 Oz.



FUEL STRAINER

**Anderson**

**HYDRAULIC  
HAND PRESS**

For faster checking and straightening operations. Checking and bending is done in same position eliminating need of removing shafts for anvils. Attachments include rolls for checking straight bars and centers for checking odd shaped parts with centers. Rolls and centers easily adjusted for different lengths of work. Press available in several sizes.



Write for Bulletin 114

**ANDERSON BROS. MFG. CO.**  
ROCKFORD, ILL., U. S. A.

★ **UTICA TOOLS** ★

**for More  
TOOL HOURS**



**T**HE demands of the times for highest operating efficiency are met by **UTICA** Pliers — made in all types — and Adjustable Wrenches. Send for Aviation Bulletin



No. 82 — No. 41.

**UTICA DROP FORGE & TOOL  
CORPORATION**  
**UTICA, NEW YORK**

**U. S. DEPARTMENT OF COMMERCE  
CIVIL AERONAUTICS ADMINISTRATION**

Washington, D. C.

Jesse H. Jones, Secretary of Commerce

William A. M. Burden, Assistant Secretary of Commerce

|                                                      |                    |
|------------------------------------------------------|--------------------|
| Administrator of Civil Aeronautics.....              | Charles I. Stanton |
| Deputy Administrator.....                            | John E. Sommers    |
| Executive Officer.....                               | A. E. Stockburger  |
| General Counsel.....                                 | Webb Shadle        |
| Director of Information and Statistics (Acting)..... | Ben Stern          |
| Director of Federal Airways.....                     | T. B. Bourne       |
| Director of Safety Regulation.....                   | Fred Lanter        |
| Director of Airports.....                            | C. B. Donaldson    |
| Executive Director of Training.....                  | R. McLean Stewart  |
| Director of War Training Service.....                | J. P. Morris       |

**Regional Managers**

|             |                          |                 |
|-------------|--------------------------|-----------------|
| Region I    | New York, N. Y.....      | Oren Harwood    |
| Region II   | Atlanta, Ga.....         | W. M. Robertson |
| Region III  | Chicago, Ill.....        | H. R. Neely     |
| Region IV   | Fort Worth, Tex.....     | L. C. Elliott   |
| Region V    | Kansas City, Mo.....     | W. E. Kline     |
| Region VI   | Santa Monica, Calif..... | H. A. Hook      |
| Region VII  | Seattle, Wash.....       | Paul Morris     |
| Region VIII | Anchorage, Alaska.....   | M. C. Hoppin    |

**U. S. FOREST SERVICE  
DEPARTMENT OF AGRICULTURE**

Washington, D. C.

Claude R. Wickard, Secretary of Agriculture

Chief of the Forest Service: Lyle F. Watts

|                            |                                                                             |
|----------------------------|-----------------------------------------------------------------------------|
| Northern Region.....       | Headquarters, Missoula, Mont.<br>Evan W. Kelley, Regional Forester          |
| Rocky Mountain Region..... | Headquarters, Denver, Colo.<br>John W. Spencer, Regional Forester           |
| Southwestern Region.....   | Headquarters, Albuquerque, N. Mex.<br>Frank C. W. Pooler, Regional Forester |
| Intermountain Region.....  | Headquarters, Ogden, Utah<br>Wm. B. Rice, Regional Forester                 |
| California Region.....     | Headquarters, San Francisco, Calif.<br>S. B. Show, Regional Forester        |
| North Pacific Region.....  | Headquarters, Portland, Ore.<br>Horace J. Andrews, Regional Forester        |
| Eastern Region.....        | Headquarters, Philadelphia, Pa.<br>R. M. Evans, Regional Forester           |
| Southern Region.....       | Headquarters, Atlanta, Ga.<br>Joseph C. Kircher, Regional Forester          |
| North Central Region.....  | Headquarters, Milwaukee, Wisc.<br>Jay H. Price, Regional Forester           |
| Alaska Region.....         | Headquarters, Juneau, Alaska<br>B. Frank Heintzleman, Regional Forester     |

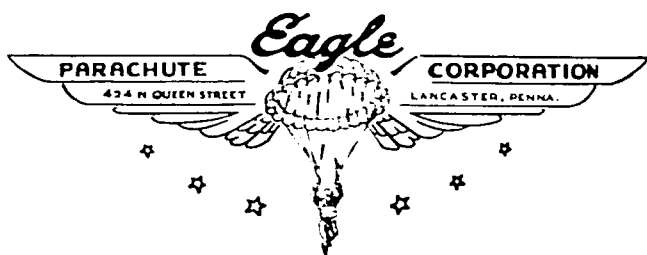

**“ADVANCED PARACHUTE EQUIPMENT”**

*Now serving the Army Air Forces; Navy Department, Bureau of Aeronautics; CAA War Training Service; and the U.S. Forest Service.*

**EAGLE PARACHUTE CORPORATION**

**Lancaster, Penna.**

*School of Aeronautics*

**STEWART  
TECHNICAL SCHOOL**

Stewart Bldg., 253-7 W. 64 St., New York 23

The **MECHANIC COURSES** prepare for Government-Approved ratings for maintenance and repair on all types of airplanes.

The **AERONAUTICAL DRAFTING COURSE** prepares for responsible Engineering Department positions.

The school is approved by the  
U. S. CIVIL AERONAUTICS ADMINISTRATION  
as an  
**AIRCRAFT AND AIRCRAFT ENGINE  
MECHANIC SCHOOL**  
also as an  
**AIRCRAFT REPAIR STATION**

Chartered by  
**THE REGENTS OF THE UNIVERSITY  
OF THE STATE OF NEW YORK**

**Founded 1909—In Aeronautics since 1929**

Approved by the  
**UNITED STATES DEPARTMENT OF LABOR**  
Foreign students may apply to an American Consul for admission into the United States for the purpose of attending this School as non-quota immigrants without regard to the quota of their country of birth.

Write for illustrated catalog.

**SINCLAIR  
AIRCRAFT  
Oils & Greases**



**SINCLAIR  
REFINING COMPANY  
630 FIFTH AVENUE  
NEW YORK 20, N. Y.**

## THE AIRCRAFT WAR PRODUCTION COUNCIL, INC.

7046 Hollywood Blvd., Los Angeles 28, Calif.

## Board of Directors

|                    |                                          |
|--------------------|------------------------------------------|
| Philip G. Johnson  | Boeing Aircraft Company                  |
| Harry Woodhead     | Consolidated Vultee Aircraft Corporation |
| Donald W. Douglas  | Douglas Aircraft Company, Inc.           |
| Robert E. Gross    | Lockheed Aircraft Corporation            |
| J. H. Kindelberger | North American Aviation, Inc.            |
| La Motte T. Cohe   | Northrop Aircraft, Inc.                  |
| T. Claude Ryan     | Ryan Aeronautical Company                |
| John C. Lee        | General Manager                          |
| William F. Peters  | Secretary-Treasurer                      |

## Committees

## Accounting Committee

|                  |                                          |
|------------------|------------------------------------------|
| H. E. Bowman     | Boeing Aircraft Company                  |
| L. K. Grant      | Consolidated Vultee Aircraft Corporation |
| R. V. Hunt       | Douglas Aircraft Company                 |
| Dudley E. Browne | Lockheed Aircraft Corporation            |
| R. A. Lambeth    | North American Aviation, Inc.            |
| Claude N. Monson | Northrop Aircraft, Inc.                  |
| James C. Noakes  | Ryan Aeronautical Company                |

## Engineering Committee

|                |                                          |
|----------------|------------------------------------------|
| W. E. Beall    | Boeing Aircraft Company                  |
| A. P. Fontaine | Consolidated Vultee Aircraft Corporation |
| A. E. Raymond  | Douglas Aircraft Company                 |
| Mac Short      | Lockheed Aircraft Corporation            |
| Gordon Throne  | North American Aviation, Inc.            |
| R. A. Dutton   | Northrop Aircraft, Inc.                  |
| B. T. Salmon   | Ryan Aeronautical Company                |

## Industrial Relations Committee

|                         |                                          |
|-------------------------|------------------------------------------|
| F. D. Weaver            | Boeing Aircraft Company                  |
| W. G. Tuttle            | Consolidated Vultee Aircraft Corporation |
| George C. Ford          | Consolidated Vultee Aircraft Corporation |
| A. C. Galbraith         | Douglas Aircraft Company                 |
| William W. Aulepp       | Lockheed Aircraft Corporation            |
| M. E. Beaman            | North American Aviation, Inc.            |
| Graham L. Sterling, Jr. | Northrop Aircraft, Inc.                  |
| W. F. Persons           | Ryan Aeronautical Company                |

## Production Expediting Committee

|                |                                          |
|----------------|------------------------------------------|
| H. O. West     | Boeing Aircraft Company                  |
| C. W. Perelle  | Consolidated Vultee Aircraft Corporation |
| F. W. Conant   | Douglas Aircraft Company                 |
| H. E. Ryker    | Lockheed Aircraft Corporation            |
| J. S. Smithson | North American Aviation, Inc.            |
| Gage H. Irving | Northrop Aircraft, Inc.                  |
| Eddie Molloy   | Ryan Aeronautical Company                |

## Public Relations Committee

|                     |                                          |
|---------------------|------------------------------------------|
| Harold Mansfield    | Boeing Aircraft Company                  |
| Arthur Foristall    | Consolidated Vultee Aircraft Corporation |
| Cliff Lewis         | Consolidated Vultee Aircraft Corporation |
| A. M. Rochlen       | Douglas Aircraft Company                 |
| Leonard K. Schwartz | Lockheed Aircraft Corporation            |
| Leland R. Taylor    | North American Aviation, Inc.            |
| Theodore C. Coleman | Northrop Aircraft, Inc.                  |
| William Wagner      | Ryan Aeronautical Company                |

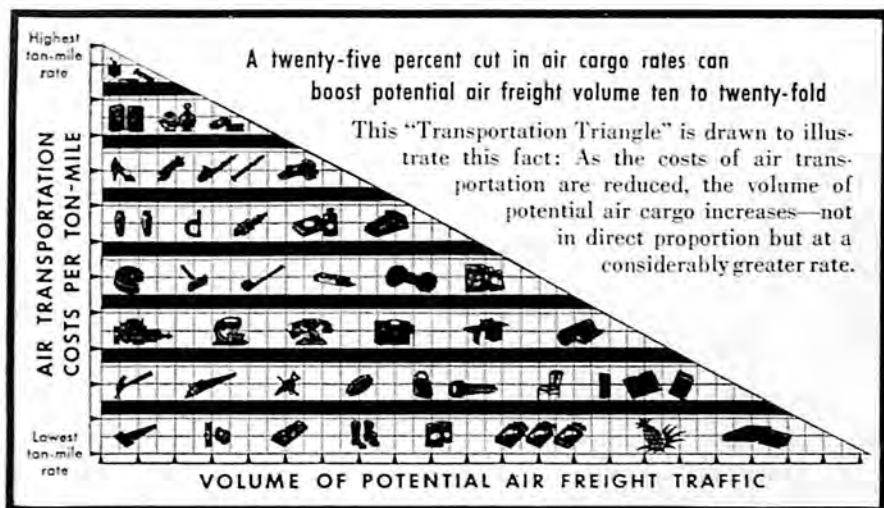

## PREDICTION: Postwar freight will fly at less than 15 cents a ton-mile

● Out of America's war-accelerated research will come new and different airplanes for a world at peace.

Planes of new, unorthodox design — capable of carrying larger loads longer distances with greater economy in operating costs.

Giant land and seaplanes. "Shuttle" craft for short hauls. Express planes of incredible speed. Airplanes to travel America's postwar products and American technicians fast and far to markets anywhere on earth.

Knowledge U. S. aircraft designers already possess is enough to guarantee this prophecy. Aircraft now

on drawing boards can be operated profitable at rates below 15 cents per ton-mile. The rates for air freight before the war were from 80 to 90 cents per ton-mile.

After victory, Northrop accomplishments, with those of other U. S. leaders, will contribute to a new world of peace and opportunity.

*Meanwhile all the resources of Northrop in airplane design and airplane construction are devoted solely to producing the deadly airplanes of war. Airplanes that help bring closer the day of complete victory for the Allies.*



**NORTHROP Aircraft, Inc.**

NORTHROP FIELD, HAWTHORNE, CALIFORNIA  
MEMBER AIRCRAFT WAR PRODUCTION COUNCIL, INC.



## AIRCRAFT WAR PRODUCTION COUNCIL

## Committees (Continued)

## Employee Services Section

|                    |                                          |
|--------------------|------------------------------------------|
| F. D. Weaver       | Boeing Aircraft Company                  |
| L. D. Larimer      | Consolidated Vultee Aircraft Corporation |
| A. R. Baish        | Consolidated Vultee Aircraft Corporation |
| George S. Hunt     | Douglas Aircraft Company                 |
| D. M. Tuttle       | Lockheed Aircraft Corporation            |
| L. M. Huettig      | North American Aviation, Inc.            |
| Walter T. Gage     | Northrop Aircraft, Inc.                  |
| E. G. O'Bryan, Jr. | Ryan Aeronautical Company                |

## Government Reports Section

|                    |                                          |
|--------------------|------------------------------------------|
| H. O. West         | Boeing Aircraft Company                  |
| R. R. Kearton      | Consolidated Vultee Aircraft Corporation |
| W. H. Robinson     | Consolidated Vultee Aircraft Corporation |
| D. M. Leigh-Taylor | Douglas Aircraft Company                 |
| I. A. Crawford     | Lockheed Aircraft Corporation            |
| F. V. Swanson      | North American Aviation, Inc.            |
| Gage H. Irving     | Northrop Aircraft, Inc.                  |
| E. C. Harris       | Northrop Aircraft, Inc.                  |
| J. C. Dengler      | Northrop Aircraft, Inc.                  |
| F. J. Rossoll      | Ryan Aeronautical Company                |

## Information Section

|                  |                                          |
|------------------|------------------------------------------|
| Harold Mansfield | Boeing Aircraft Company                  |
| Cliff Lewis      | Consolidated Vultee Aircraft Corporation |
| Don Black        | Douglas Aircraft Company                 |
| B. W. Holloway   | Lockheed Aircraft Corporation            |
| Ken Macker       | North American Aviation, Inc.            |
| Carl Apponyi     | Northrop Aircraft, Inc.                  |
| Keith Monroe     | Ryan Aeronautical Company                |

## Materiel Section

|                  |                                          |
|------------------|------------------------------------------|
| H. O. West       | Boeing Aircraft Company                  |
| E. H. Jones      | Consolidated Vultee Aircraft Corporation |
| F. W. Conant     | Douglas Aircraft Company                 |
| D. J. Bosio      | Douglas Aircraft Company                 |
| B. W. deGuichard | Lockheed Aircraft Corporation            |
| Robert Monroe    | North American Aviation, Inc.            |
| P. I. Chase      | Northrop Aircraft, Inc.                  |
| Walter O. Locke  | Ryan Aeronautical Company                |

## Outside Production Section

|                  |                                          |
|------------------|------------------------------------------|
| H. O. West       | Boeing Aircraft Company                  |
| C. W. Perelle    | Consolidated Vultee Aircraft Corporation |
| Roy Taylor       | Consolidated Vultee Aircraft Corporation |
| B. C. Monesmith  | Douglas Aircraft Company                 |
| C. A. Frick      | Lockheed Aircraft Corporation            |
| Rudy Mufich      | North American Aviation, Inc.            |
| W. C. Osborn     | Northrop Aircraft, Inc.                  |
| A. M. Kwasigroch | Ryan Aeronautical Company                |

## Plant Production Section

|                   |                                          |
|-------------------|------------------------------------------|
| H. O. West        | Boeing Aircraft Company                  |
| H. Bowling        | Consolidated Vultee Aircraft Corporation |
| J. T. MacDonald   | Douglas Aircraft Company                 |
| George H. Prudden | Lockheed Aircraft Corporation            |
| R. E. Dawe        | North American Aviation, Inc.            |
| Paul Buckner      | Northrop Aircraft, Inc.                  |
| G. E. Barton      | Ryan Aeronautical Company                |



# Wings Across the Sea

THAT FREEDOM MAY NOT DIE

Half surrounding Japan's ill-won new territories are Chinese, Indian and Australian air bases. In these countries are thousands of potentially fine pilots, as eager as their American brothers in arms to fight the common enemy.

### HELPING ARM OUR ALLIES

But *grounded* valor is of little avail against Japanese air power. Only modern training and modern equipment can turn this eagerness into effective military use.

Ryan is proud of its contribution in Asia and Australia toward this end. Widely used for training military pilots for the U. S. Army Air Forces, Ryan planes were in China and

the Netherlands East Indies in training operations before the war. Now Ryan planes are doing their full share in important military assignments for China and in Australia and India. Of course, details of these military assignments cannot now be published.

### TO STRIKE HARDER BLOWS

In addition to other vital war work, Ryan activities now include the engineering development and manufacture of advanced type combatant airplanes and important assemblies for the armed services. Into these is going knowledge that will make Ryan peacetime planes and other products safer, more useful and more economical.



# RYAN

*Rely on Ryan to Build Well*

RYAN AERONAUTICAL COMPANY, SAN DIEGO — MEMBER, AIRCRAFT WAR PRODUCTION COUNCIL, INC.  
 Ryan Products: Army PT-22s, Navy NR-1s, Army PT-25s, S-T Commercial and Military Trainers, Exhaust Manifold Systems and Bomber Assemblies.

## DIRECTORY

### AIRCRAFT WAR PRODUCTION COUNCIL Committees (Continued)

#### Recruitment Section

|                       |                                          |
|-----------------------|------------------------------------------|
| F. D. Weaver.....     | Boeing Aircraft Company                  |
| H. E. Pasok.....      | Consolidated Vultee Aircraft Corporation |
| C. S. Warner.....     | Consolidated Vultee Aircraft Corporation |
| L. N. Fitts.....      | Douglas Aircraft Company                 |
| M. V. Mattson.....    | Lockheed Aircraft Corporation            |
| L. M. Huettig.....    | North American Aviation, Inc.            |
| G. S. Honey.....      | North American Aviation, Inc.            |
| C. D. Freshwater..... | Northrop Aircraft, Inc.                  |
| J. F. Saye.....       | Ryan Aeronautical Company                |

#### Training Section

|                        |                                          |
|------------------------|------------------------------------------|
| F. D. Weaver.....      | Boeing Aircraft Company                  |
| T. P. Faulconer.....   | Consolidated Vultee Aircraft Corporation |
| George C. Ford.....    | Consolidated Vultee Aircraft Corporation |
| M. D. Faugh.....       | Douglas Aircraft Company                 |
| C. A. Pederson.....    | Lockheed Aircraft Corporation            |
| John H. Fry.....       | North American Aviation, Inc.            |
| James L. McKinley..... | Northrop Aircraft, Inc.                  |
| L. E. Plummer.....     | Ryan Aeronautical Company                |

**COMPLETE FABRICATION**

**MANUFACTURE, ASSEMBLY OF SHEET  
METAL PARTS FOR AIRCRAFT**

**SOUTHERN CALIFORNIA  
AIRPARTS**

*Division of*

**JARVIS MANUFACTURING CO.**  
924 Thompson Avenue  
Glendale, California  
U. S. A.

**LINK-BELT  
AIRCRAFT  
PRECISION BUILT  
SILENT AND ROLLER  
CHAINS**

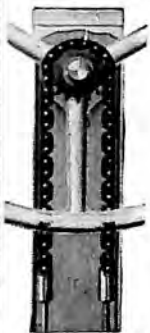

A complete line of silent and roller chains for all aircraft services—rudder and aileron controls; cowl flap controls; for retracting landing gears; on gun mounts and gun turrets, etc. Send for Engineering Data Book 1825.

9309-B

**LINK-BELT COMPANY**  
220 S. Belmont Ave., Indianapolis-6  
Offices in Principal Cities

**Kodak Aero Film**

**Kodak Aero Contact  
and Enlarging Papers**

**Cellulose Acetate  
Products**

**Kodak's new and faster  
aerial lenses, available  
at the close of  
hostilities.**

**EASTMAN KODAK  
COMPANY**

**ROCHESTER, N. Y.**

## AIRCRAFT WAR PRODUCTION COUNCIL, EAST COAST, INC.

Room 365, 630 Fifth Avenue, New York 20, New York

Telephone: Circle 6-5640

## Board of Directors

|                          |                                                       |
|--------------------------|-------------------------------------------------------|
| Victor Emanuel.....      | Aviation Corporation                                  |
| L. D. Bell.....          | Bell Aircraft Corporation                             |
| G. W. Vaughan.....       | Curtiss-Wright Corporation                            |
| L. C. Goad.....          | Eastern Aircraft Division, General Motors Corporation |
| J. Carlton Ward, Jr..... | Fairchild Engine & Airplane Corporation               |
| Glenn L. Martin.....     | The Glenn L. Martin Company                           |
| Alfred Marchev.....      | Republic Aviation Corporation                         |
|                          |                                                       |
| Clyde M. Vandeburg.....  | General Manager                                       |
| Ken Ellington.....       | Secretary and Director of Information                 |
| Harry A. Harter.....     | Assistant Manager                                     |
| Lloyd H. Smith.....      | Treasurer                                             |

## Committees

## Advisory Committee on Accounting

|                             |                                                       |
|-----------------------------|-------------------------------------------------------|
| W. A. Mogensen.....         | Aviation Corporation                                  |
| J. Berry, Jr.....           | Bell Aircraft Corporation                             |
| R. J. Lindquist.....        | Curtiss-Wright Corporation                            |
| J. A. McFetridge.....       | Eastern Aircraft Division, General Motors Corporation |
| Joseph Mehl.....            | Fairchild Engine & Airplane Corporation               |
| M. R. Schermerhorn, Jr..... | The Glenn L. Martin Company                           |
| M. B. Chesney.....          | Republic Aviation Corporation                         |

## Advisory Committee on Engineering

|                      |                                                                           |
|----------------------|---------------------------------------------------------------------------|
| S. K. Hoffman.....   | Aviation Corporation                                                      |
| R. W. Gibson.....    | Bell Aircraft Corporation (Buffalo)                                       |
| A. D. Brown.....     | Bell Aircraft Corporation (Georgia)                                       |
| H. E. McDonald.....  | Curtiss-Wright Corporation, Airplane Division                             |
| Louis H. Enos.....   | Curtiss-Wright Corporation, Propeller Division                            |
| Walter F. Burke..... | Eastern Aircraft Division, General Motors Corporation                     |
| A. J. Thieblot.....  | Fairchild Engine & Airplane Corporation                                   |
| Edwin L. Zivi.....   | The Glenn L. Martin Company                                               |
| A. T. Gregory.....   | Ranger Aircraft Engines Division, Fairchild Engine & Airplane Corporation |
| R. L. Bortner.....   | Republic Aviation Corporation                                             |

## Advisory Committee on Industrial Relations—Manpower

## Industrial Relations Section

|                         |                                                                           |
|-------------------------|---------------------------------------------------------------------------|
| C. W. Bishop.....       | Aviation Corporation                                                      |
| Vaughan Bell.....       | Bell Aircraft Corporation (Buffalo)                                       |
| B. H. Prentice, Jr..... | Bell Aircraft Corporation (Georgia)                                       |
| C. S. Mattoon.....      | Curtiss-Wright Corporation, Airplane Division                             |
| Norman A. Kirby.....    | Curtiss-Wright Corporation, Propeller Division                            |
| A. A. Hendrix.....      | Eastern Aircraft Division, General Motors Corporation                     |
| S. A. Angotti.....      | Fairchild Engine & Airplane Corporation                                   |
| D. W. Siemon.....       | The Glenn L. Martin Company                                               |
| H. S. Hall.....         | Ranger Aircraft Engines Division, Fairchild Engine & Airplane Corporation |
| A. L. Kress.....        | Republic Aviation Corporation                                             |

## Manpower Section

|                       |                                                       |
|-----------------------|-------------------------------------------------------|
| E. R. Isbell.....     | Aviation Corporation                                  |
| Leston P. Faneuf..... | Bell Aircraft Corporation (Buffalo)                   |
| Ivan Willis.....      | Curtiss-Wright Corporation                            |
| R. E. Waldo.....      | Eastern Aircraft Division, General Motors Corporation |
| S. A. Angotti.....    | Fairchild Engine & Airplane Corporation               |
| D. W. Siemon.....     | The Glenn L. Martin Company                           |
| A. L. Kress.....      | Republic Aviation Corporation                         |



**Add another chapter to the history of  
American aviation JET PROPULSION**

You're looking at the performance of the first jet propelled airplane to be accepted by the United States Army Air Forces.

In England there was designed a revolutionary new type of engine which could propel a plane through the sky by spewing out a terrific blast of air.

The General Electric Company here in America further developed and built engines utilizing this principle.

By choice of both G.E. and the Army Air Forces officials, Bell Aircraft was selected to design and construct planes incorporating this Jet Propulsion engine.

Now that the story of this new jet propelled plane can be told, Bell Aircraft wishes publicly to express its appreciation to the officers of the Army Air Forces who have contributed so much to this project. We have learned many things which will aid us to pioneer in building safer, better and lower-priced aircraft when peace returns.

Member Aircraft War Production Council  
East Coast, Inc.

**BELL AIRCRAFT**  
**PACEMAKER OF AVIATION PROGRESS**

Niagara Frontier Division, Buffalo-Niagara Falls, N. Y.  
Ordnance Division, Burlington, Vt.  
Georgia Division, Marietta, Ga.

## AIRCRAFT WAR PRODUCTION COUNCIL, EAST COAST Committees (Continued)

### Advisory Committee on Material

|                       |                                                                              |
|-----------------------|------------------------------------------------------------------------------|
| D. T. Waltz.....      | Aviation Corporation                                                         |
| O. D. May.....        | Bell Aircraft Corporation (Buffalo)                                          |
| Robert Boyer, Jr..... | Bell Aircraft Corporation (Georgia)                                          |
| Frank A. Maley.....   | Curtiss-Wright Corporation, Airplane Division                                |
| W. W. Gleeson.....    | Curtiss-Wright Corporation, Propeller Division                               |
| H. L. Clark.....      | Eastern Aircraft Division, General Motors Corporation                        |
| O. R. Perkins.....    | Fairchild Engine & Airplane Corporation                                      |
| J. T. Welsh.....      | The Glenn L. Martin Company                                                  |
| F. D. Hubbard.....    | Ranger Aircraft Engines, Division of Fairchild Engine & Airplane Corporation |
| R. H. McMann.....     | Republic Aviation Corporation                                                |

### Advisory Committee on Plant Defense

|                         |                                                                              |
|-------------------------|------------------------------------------------------------------------------|
| D. H. Russ.....         | Aviation Corporation                                                         |
| John T. Madigan.....    | Bell Aircraft Corporation (Buffalo)                                          |
| B. H. Prentice, Jr..... | Bell Aircraft Corporation (Georgia)                                          |
| I. F. LeGore.....       | Curtiss-Wright Corporation, Airplane Division                                |
| P. J. Quinn.....        | Curtiss-Wright Corporation, Propeller Division                               |
| E. T. Adams.....        | Eastern Aircraft Division, General Motors Corporation                        |
| John A. White.....      | Fairchild Engine & Airplane Corporation                                      |
| E. A. Schurman.....     | The Glenn L. Martin Company                                                  |
| C. M. Burke.....        | Ranger Aircraft Engines, Division of Fairchild Engine & Airplane Corporation |
| Arthur J. Kelly.....    | Republic Aviation Corporation                                                |

### Advisory Committee on Production

|                      |                                                                              |
|----------------------|------------------------------------------------------------------------------|
| L. L. Benson.....    | Bell Aircraft Corporation (Buffalo)                                          |
| J. J. Domonkos.....  | Bell Aircraft Corporation (Georgia)                                          |
| John J. Lee.....     | Curtiss-Wright Corporation, Airplane Division                                |
| Philip E. Baugh..... | Eastern Aircraft Division, General Motors Corporation                        |
| E. J. Hanson.....    | Eastern Aircraft Division, General Motors Corporation                        |
| Philip Harr.....     | Fairchild Engine & Airplane Corporation                                      |
| Robert Young.....    | The Glenn L. Martin Company                                                  |
| H. H. Budds.....     | Ranger Aircraft Engines, Division of Fairchild Engine & Airplane Corporation |
| H. E. Lasker.....    | Republic Aviation Corporation                                                |

### Advisory Committee on Public Relations

|                       |                                                       |
|-----------------------|-------------------------------------------------------|
| Edward Thierry.....   | Aviation Corporation                                  |
| Walter T. Bonney..... | Bell Aircraft Corporation (Buffalo)                   |
| Richard Harkins.....  | Bell Aircraft Corporation (Georgia)                   |
| H. E. Lawrence.....   | Curtiss-Wright Corporation                            |
| Adrian W. Smith.....  | Curtiss-Wright Corporation, Airplane Division         |
| S. S. Tyndall.....    | Curtiss-Wright Corporation, Propeller Division        |
| J. N. Bird.....       | Eastern Aircraft Division, General Motors Corporation |
| J. E. Lowes, Jr.....  | Fairchild Engine & Airplane Corporation               |
| Avery McBee.....      | The Glenn L. Martin Company                           |
| Gordon Sleeper.....   | Republic Aviation Corporation                         |

### Advisory Committee on Quality

|                     |                                                       |
|---------------------|-------------------------------------------------------|
| J. W. Dunn.....     | Curtiss-Wright Corporation, Airplane Division         |
| F. C. Fake.....     | Curtiss-Wright Corporation, Propeller Division        |
| R. H. Seaman.....   | Eastern Aircraft Division, General Motors Corporation |
| C. C. Aurand.....   | Eastern Aircraft Division, General Motors Corporation |
| W. A. Shuping.....  | Fairchild Engine & Airplane Corporation               |
| C. G. Stephens..... | The Glenn L. Martin Company                           |
| A. Dysart.....      | Republic Aviation Corporation                         |



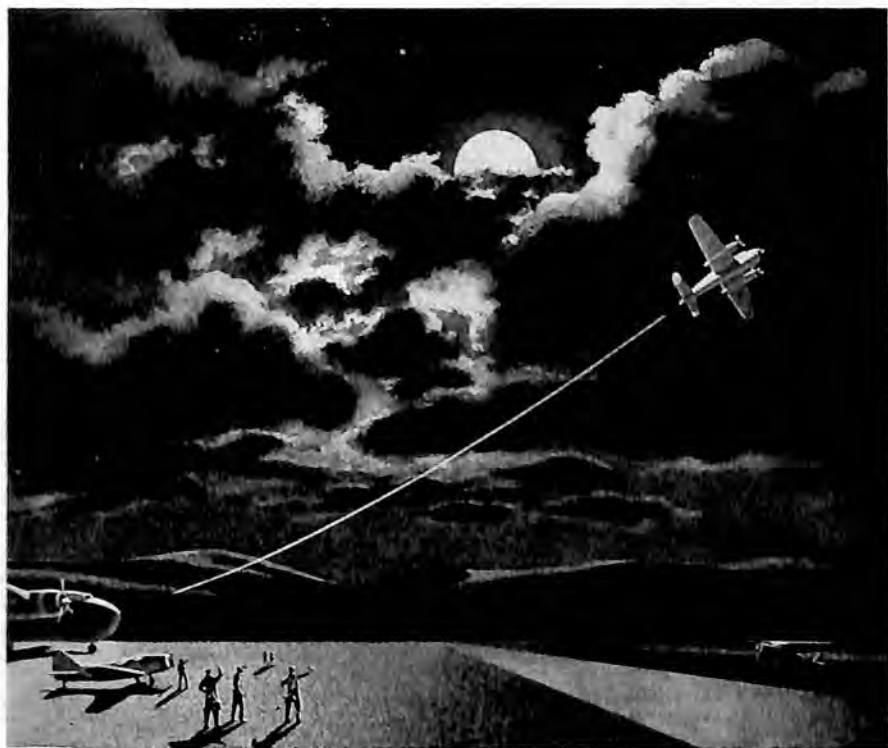

## The Touch of Tomorrow in the Planes of Today

Fairchild engineers look upon airplanes and airplane engines as tools for the achievement of specific and frequently different flight tasks.

Men fly to perform a number of different jobs. Some fly to learn the art of flight; others fly to learn the science of attack and defense; still others fly to carry goods and persons to far places.

Ever since the first Fairchild was built, Fairchild engineers have designed and constructed aircraft to do *specific jobs well*. This was true of the world's first photographic airplane—true of the Army's first cargo carrier. It is true of the PT-19 "Cornell" in which thousands of American combat pilots have fledged their wings; true of the AT-21 "Gunner," a twin-engined plane with a Duramolded skin of plastic-bonded ply-

wood; and true of the UC-61 "Forwarder," the dependable little shuttle plane that operates just behind the lines on many a fighting front. This facility for building aircraft for top performance at *specific jobs* characterizes, too, the design for Fairchild's new and *unique* cargo plane scheduled for production this year.

Fairchild Ranger engines—six and twelve cylinders—are the only inverted, inline, aircooled aircraft engines produced in America today. Each is designed for a specific purpose—to produce the greatest power with the least possible weight.

Fairchild engineers will continue to employ science, research, experience and foresight, to design and build aircraft and aircraft engines that put "the touch of tomorrow in the planes of today."



**FAIRCHILD**

ENGINE AND AIRPLANE CORPORATION

30 ROCKEFELLER PLAZA, NEW YORK

Ranger Aircraft Engines Division  
Farmingdale, L. I.

Duramold Division  
New York, N. Y.

Fairchild Aircraft Division  
Hagerstown, Md. . . . Burlington, N. C.

## AIRCRAFT WAR PRODUCTION COUNCIL, EAST COAST Committees (Continued)

### Advisory Committee on Service

|                    |                                                                              |
|--------------------|------------------------------------------------------------------------------|
| Barney Cane.....   | Aviation Corporation                                                         |
| A. L. Fornoff..... | Bell Aircraft Corporation (Buffalo)                                          |
| W. V. Andrews..... | Curtiss-Wright Corporation, Airplane Division                                |
| F. Brychta.....    | Curtiss-Wright Corporation, Propeller Division                               |
| Allen Wescott..... | Eastern Aircraft Division, General Motors Corporation                        |
| Glen Ewins.....    | Fairchild Engine & Airplane Corporation                                      |
| T. L. Taylor.....  | The Glenn L. Martin Company                                                  |
| D. S. Wolf.....    | Ranger Aircraft Engines, Division of Fairchild Engine & Airplane Corporation |
| D. K. Tasker.....  | Republic Aviation Corporation                                                |

### Advisory Committee on Spare Parts

|                       |                                                                              |
|-----------------------|------------------------------------------------------------------------------|
| Barney Cane.....      | Aviation Corporation                                                         |
| T. G. Haertel.....    | Bell Aircraft Corporation (Buffalo)                                          |
| C. W. Kraus.....      | Curtiss-Wright Corporation, Airplane Division                                |
| James Thomson.....    | Curtiss-Wright Corporation, Propeller Division                               |
| Allen Wescott.....    | Eastern Aircraft Division, General Motors Corporation                        |
| F. Kent Bradford..... | Fairchild Engine & Airplane Corporation                                      |
| W. F. Davis.....      | The Glenn L. Martin Company                                                  |
| T. M. Wells.....      | Ranger Aircraft Engines, Division of Fairchild Engine & Airplane Corporation |
| E. W. Kulesh.....     | Republic Aviation Corporation                                                |

### Advisory Sub-Committee on Conservation and Reclamation

#### (Subcommittee of Advisory Committee on Production)

|                       |                                                                              |
|-----------------------|------------------------------------------------------------------------------|
| A. Lansill.....       | Bell Aircraft Corporation (Buffalo)                                          |
| A. C. Keiser, Jr..... | Bell Aircraft Corporation (Georgia)                                          |
| D. Hamill.....        | Curtiss-Wright Corporation, Airplane Division                                |
| R. S. Sharp.....      | Curtiss-Wright Corporation, Propeller Division                               |
| Earl H. Streeter..... | Eastern Aircraft Division, General Motors Corporation                        |
| Willard Brown.....    | Eastern Aircraft Division, General Motors Corporation                        |
| J. W. Buffington..... | Fairchild Engine & Airplane Corporation                                      |
| Ross B. Hooker.....   | The Glenn L. Martin Company                                                  |
| R. Hohman.....        | Ranger Aircraft Engines, Division of Fairchild Engine & Airplane Corporation |
| Frank Zinc.....       | Republic Aviation Corporation                                                |

### Advisory Sub-Committee on Employee Services

#### (Subcommittee of Advisory Committee on Industrial Relations)

|                         |                                                                              |
|-------------------------|------------------------------------------------------------------------------|
| Claire W. Bishop.....   | Aviation Corporation                                                         |
| Alexander McDonald..... | Bell Aircraft Corporation (Buffalo)                                          |
| J. J. Wadsworth.....    | Curtiss-Wright Corporation, Airplane Division                                |
| John H. Quinn.....      | Curtiss-Wright Corporation, Propeller Division                               |
| A. A. Hendrix.....      | Eastern Aircraft Division, General Motors Corporation                        |
| George H. Rowe.....     | Fairchild Engine & Airplane Corporation                                      |
| William Hester.....     | Ranger Aircraft Engines, Division of Fairchild Engine & Airplane Corporation |
| John J. Lyons.....      | Republic Aviation Corporation                                                |

Blazing the Trail to  
 Tomorrow with the  
**MIGHTY MARTIN MARS!**



The world knows, now, what the 75-ton Martin Mars can do. It's an established fact that she can transport 150 soldiers with full equipment . . . that she can carry 20 tons of cargo to the farthest spot on earth in 5 days or less . . . that she's the most efficient airplane yet built, per pound of material used, per horsepower and per gallon of fuel. Feats like her non-stop flight from Patuxent River, Md. to Natal, Brazil . . . 4,375 miles with a load of 16 persons and 13,000 pounds of mail . . . have proven the record-breaking characteristics of this giant flying boat. In regular service with the Navy, the Mars is shortening supply lines in the Pacific.

*Multiply By Twenty-One!*

Twenty sisterships of the Mars are now being built for the Navy. This will mean that 3,150 men can be rushed to distant fronts in a matter

of hours . . . that 840,000 pounds of supplies can reach any spot on earth in 5 days or less! What over-ocean airline wouldn't "give its eye-teeth" for a fleet like that?

*Only A Beginning*

Commercial versions of the Mars will offer every comfort, every luxury, to tomorrow's travellers. Yet even these airliners will be only a beginning. Martin engineers declare there is *no practical aerodynamic limit to the size of over-ocean aircraft.*

THE GLENN L. MARTIN COMPANY  
 BALTIMORE-3, MARYLAND  
 The Glenn L. Martin - Nebraska  
 Company—Omaha

**Martin**  
**AIRCRAFT**

Builders of Dependable



Aircraft Since 1909

## AERONAUTICAL PERIODICALS OF THE UNITED STATES

|                                      |                                            |
|--------------------------------------|--------------------------------------------|
| AERO DIGEST                          | 515 Madison Avenue, New York, N. Y.        |
| AERONAUTICAL REVIEW                  | 30 Rockefeller Plaza, New York, N. Y.      |
| AIR FACTS                            | 30 Rockefeller Plaza, New York, N. Y.      |
| AIR LAW REVIEW                       | Washington Square East, New York, N. Y.    |
| AIR LINE MECHANIC                    | 6240 S. Kedzie Avenue, Chicago, Ill.       |
| AIR LINE PILOT                       | 3145 W. 63rd Street, Chicago, Ill.         |
| AIR NEWS                             | 545 Fifth Avenue, New York, N. Y.          |
| AIR TECH                             | 545 Fifth Avenue, New York, N. Y.          |
| AIR TRAILS                           | 79 Seventh Avenue, New York, N. Y.         |
| AIR TRANSPORT                        | 330 W. 42nd Street, New York, N. Y.        |
| AIRCRAFT YEAR BOOK (ANNUAL)          | 10 Rockefeller Plaza, New York, N. Y.      |
| AIRLANES                             | 304 West 57th Street, New York, N. Y.      |
| AIRPORT REFERENCE                    | 304 S. Broadway, Los Angeles, Calif.       |
| AMERICAN AVIATION                    | 1317 F Street N. W., Washington, D. C.     |
| AMERICAN AVIATION DAILY              | 1317 F Street N. W., Washington, D. C.     |
| AMERICAN AVIATION DIRECTORY          | 1317 F Street N. W., Washington, D. C.     |
| AVIATION                             | 330 W. 42nd Street, New York, N. Y.        |
| AVIATION EQUIPMENT                   | 1170 Broadway, New York, N. Y.             |
| AVIATION NEWS                        | 330 W. 42nd Street, New York, N. Y.        |
| FLYING                               | 540 N. Michigan Avenue, Chicago, Ill.      |
| FLYING ACES                          | 29 Worthington Street, Springfield, Mass.  |
| JOURNAL OF AIR LAW                   | 357 E. Chicago Avenue, Chicago, Ill.       |
| JOURNAL OF THE AERONAUTICAL SCIENCES | 30 Rockefeller Plaza, New York, N. Y.      |
| MODEL AIRPLANE NEWS                  | 551 Fifth Avenue, New York, N. Y.          |
| NATIONAL AERONAUTICS                 | 1025 Connecticut Avenue, Washington, D. C. |
| OFFICIAL AVIATION GUIDE              | 608 S. Dearborn Street, Chicago, Ill.      |
| SKYWAYS                              | 444 Madison Avenue, New York, N. Y.        |
| SOUTHERN FLIGHT                      | 1901 McKinney Avenue, Dallas, Tex.         |
| SPORTSMAN PILOT                      | 515 Madison Avenue, New York, N. Y.        |
| U. S. AIR SERVICES                   | Transportation Building, Washington, D. C. |
| WESTERN FLYING                       | 304 S. Broadway, Los Angeles, Calif.       |

*Makers of*

Aerial Photographs and Maps of Superior Quality  
Since 1924

*Manufacturers of*

SONNE Shutterless, Continuous Strip Aerial Cameras  
Black and White                      Color                      Stereoscopic

Especially adapted to rapid, large scale surveys of  
Highways, Rivers, Railroads, Rights of Ways, etc.

SONNE Automatic Continuous Photo Printer

For rapid and accurate printing of commercial and  
aerial negatives.

— Available After The War —

**CHICAGO AERIAL SURVEY COMPANY**

332 SOUTH MICHIGAN AVENUE, 4, CHICAGO

*Contractor to U. S. Army and Navy Air Forces*

**WICKES  
A U T O -  
M A T I C  
C E N T E R  
D R I V E  
C R A N K -  
S H A F T  
L A T H E**

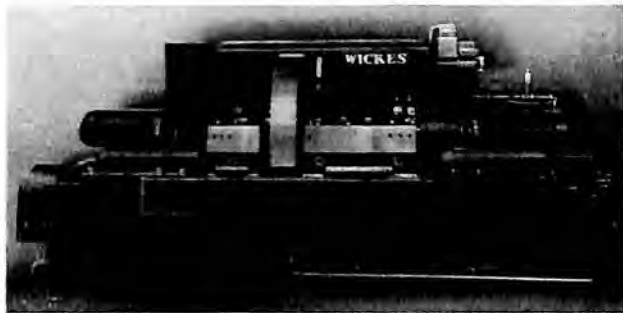

This efficient new Wickes Model CH-8 Automatic Center Drive type lathe is ideal for machining the main line bearings, stub-end, flange and oil slinger complete on crankshafts for airplane, truck and tractor, both gasoline and Diesel engines. By setting up duplicate lathes, the second tooled for finish turning the same parts, you can save considerable time and labor by eliminating rough grinding operations. • Entire operation is automatic and controlled by an electrical push-button panel. We build a complete line of lathes for turning main bearings and crankpin bearings.

**WICKES BROTHERS • SAGINAW, MICHIGAN • RECOGNIZED QUALITY SINCE 1854**  
Crankshaft Turning Equipment • Double-End Boring, Heavy Duty Engine, and Special Production Lathes • Simplex Blue Printers

## CONGRESSIONAL COMMITTEES INTERESTED IN AVIATION

Standing Committees of the 78th Congress

## Senate

## Appropriations

|                        |     |                        |     |
|------------------------|-----|------------------------|-----|
| Carter Glass           | (D) | Dennis Chavez          | (D) |
| Kenneth McKellar       | (D) | James M. Mead          | (D) |
| Carl Hayden            | (D) | Burnet R. Maybank      | (D) |
| Elmer Thomas           | (D) | Gerald P. Nye          | (R) |
| Millard E. Tydings     | (D) | Styles Bridges         | (R) |
| Richard B. Russell     | (D) | Henry Cabot Lodge, Jr. | (R) |
| Pat McCarran           | (D) | Rufus C. Holman        | (R) |
| John H. Overton        | (D) | Wallace H. White, Jr.  | (R) |
| John H. Bankhead, 2d   | (D) | Chan Gurney            | (R) |
| Joseph C. O'Mahoney    | (D) | C. Wayland Brooks      | (R) |
| Harry S. Truman        | (D) | Clyde M. Reed          | (R) |
| Theodore Francis Green | (D) | Harold H. Burton       | (R) |
| Francis Maloney        | (D) |                        |     |

## Interstate Commerce

|                   |     |                       |     |
|-------------------|-----|-----------------------|-----|
| Burton K. Wheeler | (D) | Ernest W. McFarland   | (D) |
| Ellison D. Smith  | (D) | Wallace H. White, Jr. | (R) |
| Robert F. Wagner  | (D) | Warren R. Austin      | (R) |
| Alben W. Barkley  | (D) | Henrik Shipstead      | (R) |
| Homer T. Bone     | (D) | Charles W. Tobey      | (R) |
| Harry S. Truman   | (D) | Clyde M. Reed         | (R) |
| Edwin C. Johnson  | (D) | Chan Gurney           | (R) |
| Lister Hill       | (D) | C. Wayland Brooks     | (R) |
| Tom Stewart       | (D) | Albert W. Hawkes      | (R) |
| D. Worth Clark    | (D) | E. H. Moore           | (R) |
| James M. Tunnell  | (D) |                       |     |

## Military Affairs

|                    |     |                        |     |
|--------------------|-----|------------------------|-----|
| Robert R. Reynolds | (D) | James E. Murray        | (D) |
| Elbert D. Thomas   | (D) | Joseph C. O'Mahoney    | (D) |
| Edwin C. Johnson   | (D) | Warren R. Austin       | (R) |
| Lister Hill        | (D) | Styles Bridges         | (R) |
| Sheridan Downey    | (D) | Chan Gurney            | (R) |
| Albert B. Chandler | (D) | Rufus C. Holman        | (R) |
| Harry S. Truman    | (D) | Henry Cabot Lodge, Jr. | (R) |
| Mon C. Wallgren    | (D) | Chapman Revercomb      | (R) |
| Harley M. Kilgore  | (D) | George A. Wilson       | (R) |

## Naval Affairs

|                    |     |                   |     |
|--------------------|-----|-------------------|-----|
| David I. Walsh     | (D) | Allen J. Ellender | (D) |
| Millard E. Tydings | (D) | Scott W. Lucas    | (D) |
| Ellison D. Smith   | (D) | Arthur Walsh      | (D) |
| Richard B. Russell | (D) | James J. Davis    | (R) |
| Homer T. Bone      | (D) | Hiram W. Johnson  | (R) |
| Harry Flood Byrd   | (D) | Alexander Wiley   | (R) |
| Peter G. Gerry     | (D) | Owen Brewster     | (R) |
| Charles O. Andrews | (D) | Charles W. Tobey  | (R) |
| Guy M. Gillette    | (D) | Raymond E. Willis | (R) |

## Post Offices and Post Roads

|                   |     |                     |     |
|-------------------|-----|---------------------|-----|
| Kenneth McKellar  | (D) | John L. McClellan   | (D) |
| Carl Hayden       | (D) | Clyde M. Reed       | (R) |
| Josiah W. Bailey  | (D) | William Langer      | (R) |
| Dennis Chavez     | (D) | C. Douglass Buck    | (R) |
| Allen J. Ellender | (D) | Harlan J. Bushfield | (R) |
| James M. Mead     | (D) | Homer Ferguson      | (R) |
| Sheridan Downey   | (D) | E. H. Moore         | (R) |
| W. Lee O'Daniel   | (D) | Edward V. Robertson | (R) |
| James G. Scrugham | (D) | George A. Wilson    | (R) |
| James O. Eastland | (D) |                     |     |

LIGHTING CABLES • SYNTHETIC & FLAMEPROOF  
EVERY MAN, WOMAN & MACHINE

AT

C R E S C E N T



IS WORKING 100% TO KEEP THE  
LIGHT OF FREEDOM BURNING

CRESCENT INSULATED WIRE & CABLE CO.  
TRENTON, N. J.

CRESFLEX NON-METALLIC SHEATHED CABLE • VARNISHED CAMBRIC • AIRCRAFT POWER &

INSULATION • RADIO WIRES • SIGNAL CABLE • FLEXIBLE CORDS • ARMORED CABLE

• IMPERIAL NEOPRENE JACKETED PORTABLE CABLE •



CONGRESSIONAL COMMITTEES INTERESTED IN AVIATION  
(Continued)

## House of Representatives

## Appropriations

|                      |     |                         |     |
|----------------------|-----|-------------------------|-----|
| Clarence Cannon      | (D) | Clinton P. Anderson     | (D) |
| Clifton A. Woodrum   | (D) | Jamie L. Whitten        | (D) |
| Louis Ludlow         | (D) | Thomas J. O'Brien       | (D) |
| Malcolm C. Tarver    | (D) | James M. Curley         | (D) |
| Jed Johnson          | (D) | John Taber              | (R) |
| J. Buell Snyder      | (D) | Richard B. Wigglesworth | (R) |
| Emmet O'Neal         | (D) | William P. Lambertson   | (R) |
| James M. Fitzpatrick | (D) | D. Lane Powers          | (R) |
| Louis C. Rabaut      | (D) | Albert E. Carter        | (R) |
| Joe Starnes          | (D) | Charles A. Plumley      | (R) |
| John H. Kerr         | (D) | Everett M. Dirksen      | (R) |
| George H. Mahon      | (D) | Albert J. Engel         | (R) |
| Harry R. Sheppard    | (D) | Karl Stefan             | (R) |
| Butler B. Hare       | (D) | Francis Case            | (R) |
| Albert Thomas        | (D) | Frank B. Keefe          | (R) |
| Joe Hendricks        | (D) | Noble J. Johnson        | (R) |
| Michael J. Kirwan    | (D) | Robert F. Jones         | (R) |
| John M. Coffee       | (D) | Ben F. Jensen           | (R) |
| W. F. Norrell        | (D) | H. Carl Andersen        | (R) |
| Albert Gore          | (D) | Henry C. Dworshak       | (R) |
| Elmer H. Wene        | (D) | Walter C. Ploeser       | (R) |

## Interstate and Foreign Commerce

|                         |     |                      |     |
|-------------------------|-----|----------------------|-----|
| Clarence F. Lea         | (D) | Richard F. Harless   | (D) |
| Robert Crosser          | (D) | John P. Newsome      | (D) |
| Alfred L. Bulwinkle     | (D) | Charles A. Wolverton | (R) |
| Virgil Chapman          | (D) | Pehr G. Holmes       | (R) |
| Lyle H. Boren           | (D) | B. Carroll Reece     | (R) |
| Martin J. Kennedy       | (D) | Charles A. Halleck   | (R) |
| Donald L. O'Toole       | (D) | Carl Hinshaw         | (R) |
| Lindley Beckworth       | (D) | Clarence J. Brown    | (R) |
| Thomas D'Alesandro, Jr. | (D) | Evan Howell          | (R) |
| Francis J. Myers        | (D) | Harve Tibbott        | (R) |
| J. Percy Priest         | (D) | Leonard W. Hall      | (R) |
| Oren Harris             | (D) | Thomas D. Winter     | (R) |
| George G. Sadowski      | (D) | Joseph P. O'Hara     | (R) |

## Military Affairs

|                      |     |                      |     |
|----------------------|-----|----------------------|-----|
| Andrew J. May        | (D) | Bolivar Pagan        | (D) |
| R. Ewing Thomason    | (D) | Walter G. Andrews    | (R) |
| Matthew J. Merritt   | (D) | Dewey Short          | (R) |
| John M. Costello     | (D) | Leslie C. Arends     | (R) |
| Overton Brooks       | (D) | Charles R. Clason    | (R) |
| John J. Sparkman     | (D) | J. Parnell Thomas    | (R) |
| Paul J. Kilday       | (D) | Paul W. Shafer       | (R) |
| Carl T. Durham       | (D) | Thomas E. Martin     | (R) |
| Clifford Davis       | (D) | Charles H. Elston    | (R) |
| John Edward Sheridan | (D) | Forest A. Harness    | (R) |
| Robert L. F. Sikes   | (D) | Ivor D. Fenton       | (R) |
| Philip J. Philbin    | (D) | J. Leroy Johnson     | (R) |
| Paul Stewart         | (D) | Clare Boothe Luce    | (R) |
| Anthony J. Dimond    | (D) | Joseph R. Farrington | (R) |
| Arthur Winstead      | (D) |                      |     |

## Naval Affairs

|                    |     |                   |     |
|--------------------|-----|-------------------|-----|
| Carl Vinson        | (D) | Anthony J. Dimond | (D) |
| Patrick H. Drewry  | (D) | Bolivar Pagan     | (D) |
| Leonard W. Schuetz | (D) | Melvin J. Maas    | (R) |
| Warren G. Magnuson | (D) | James W. Mott     | (R) |

# WORLD LEADERSHIP!



## PRODUCTS . . .

CONTACTS — Silver, Platinum, Tungsten, Powder Metal

THERMOSTATIC METAL — High and Low Temperature and Electrical Resistance from 24 to 530 ohms per sq. mil. ft.

PRECIOUS METAL COLLECTOR RINGS

SILVER CLAD STEEL for bearings and shims

JACKETED WIRE — Silver on Steel  
Silver on Copper  
Silver on Invar or any other metal requested

### THE H. A. WILSON CO.

165 Chestnut St., Newark, N. J.  
Branch Offices: Chicago • Detroit



## AIRCRAFT TAPES AND FABRICS

★ A complete line of aircraft fabrics and tapes carries the famous Thurston Airwing label. These products include Army and Navy specification cloths, balloon fabrics, glider fabrics, utility cloths, and light-weight fabrics. Plus a distinguished group of aircraft tapes for all purposes.



**W. HARRIS THURSTON, Inc.**  
Div. of Reeves Brothers, Inc.

40 WORTH STREET, NEW YORK, N. Y.



*Serving . . .*

## WESTERN INDUSTRIES

WITH  
CRANE AND PRODUCTION LINE  
SYSTEMS AND EQUIPMENT

*Creators of . . .*

The **STABILIZED** Crane  
and  
**Gyro Float** Engine Test Stand

### SPENCER & MORRIS

ESTABLISHED 1919

5649 Alhambra Ave.  
Los Angeles 32, Calif.  
CApital 5103

CLEVELAND TRAMRAIL  
SERVICE CASTERS  
& TRUCKS

82 Beale St.  
San Francisco 5  
YUkon 1941

ENGINEERS — DESIGNERS — BUILDERS OF MATERIALS HANDLING SYSTEMS

CONGRESSIONAL COMMITTEES INTERESTED IN AVIATION  
(Continued)

Naval Affairs (Continued)

|                    |     |                      |     |
|--------------------|-----|----------------------|-----|
| Lyndon B. Johnson  | (D) | W. Sterling Cole     | (R) |
| Michael J. Bradley | (D) | George J. Bates      | (R) |
| Beverly M. Vincent | (D) | William E. Hess      | (R) |
| Ed. V. Izac        | (D) | John Z. Anderson     | (R) |
| Lansdale G. Sasser | (D) | James Wolfenden      | (R) |
| James J. Heffernan | (D) | William W. Blackney  | (R) |
| L. Mendell Rivers  | (D) | Ward Johnson         | (R) |
| F. Edward Hebert   | (D) | Robert A. Grant      | (R) |
| John E. Fogarty    | (D) | Margaret Chase Smith | (R) |
| Winder R. Harris   | (D) | Joseph R. Farrington | (R) |
| Cameron Morrison   | (D) |                      |     |

Post Offices and Post Roads

|                     |     |                      |        |
|---------------------|-----|----------------------|--------|
| Thomas G. Burch     | (D) | Harold C. Hagen      | (F.L.) |
| B. Frank Wheelchel  | (D) | Fred A. Hartley, Jr. | (R)    |
| David J. Ward       | (D) | Noah M. Mason        | (R)    |
| George D. O'Brien   | (D) | Fred J. Douglas      | (R)    |
| Samuel A. Weiss     | (D) | John C. Butler       | (R)    |
| James H. Fay        | (D) | Thomas Byron Miller  | (R)    |
| Charles E. McKenzie | (D) | William J. Miller    | (R)    |
| Chet Holifield      | (D) | Chester E. Merrow    | (R)    |
| Tom Murray          | (D) | William C. Cole      | (R)    |
| Emory H. Price      | (D) | Ed Rowe              | (R)    |
| Ray J. Madden       | (D) | Charles B. Hoeven    | (R)    |



**A Complete Range of  
HYDRAULIC SURFACE GRINDERS  
SPECIAL AIRCRAFT GRINDERS**

BROACH - SPLINE  
SLOT GRINDING AND  
MACHINE TOOL WAY GRINDERS



POWER ELEVATION  
FINGER TIP CONTROLS  
AUTOMATIC DOWN FEED  
AUTOMATIC WHEEL TRUING  
HYDRAULIC RAPID TRAVERSE  
AUTOMATIC SPARK-OUT CONTROL

SURFACE - 6 × 10 × 18 to 36 × 36 × 240  
BROACH - 6 × 48 to 12 × 72

Both for Flat and Round Broaches

**THE  
THOMPSON GRINDER COMPANY**  
West Main at Zischler St., Springfield, Ohio, U. S. A.



**AN  
and  
AC**

515  
520  
500A  
501A  
526  
530  
531  
535  
540  
545  
550  
560  
565  
566  
935  
936  
940  
945  
960  
970  
8013



**AVIATION  
SCREW PRODUCTS**

**AN  
and  
AC**

70  
302  
340  
345  
350  
380  
385  
500  
501  
505  
510

**A** LUMINUM washers delivered from stock in all popular sizes. Machine screws, set screws, sheet metal screws, wood screws; all heads, points and threads, all metals, all platings, all supplementary operations. Lock washers, nuts, wing nuts, cotters. Write for complete new catalog.

**MANUFACTURERS SCREW PRODUCTS**  
290 WEST HUBBARD STREET, CHICAGO 10, ILL.



## Flying Facts and Figures

| SUBJECT                                                                 | PAGE    |
|-------------------------------------------------------------------------|---------|
| Summary of Air Carrier Operations . . . . .                             | 680     |
| Status of Air Carrier Operations . . . . .                              | 680     |
| Monthly Air Carrier Operations . . . . .                                | 682     |
| United States Air Transport Routes . . . . .                            | 684-690 |
| U. S. Domestic Air Carrier Operations, Accident<br>Statistics . . . . . | 690     |
| Progress of Civil Aeronautics in the United States                      | 694-698 |
| American Airplanes in War Service . . . . .                             | 700-702 |
| Aircraft Labor Statistics . . . . .                                     | 698     |
| Licensed Ground Instructors in the United States . . .                  | 704     |
| Airports and Landing Fields . . . . .                                   | 706     |

## SUMMARY OF AIR CARRIER OPERATIONS

## Air Lines in the United States

Compiled by Information and Statistics Service, U. S. Civil Aeronautics Administration  
Calendar Years

| Year | Operators | Planes in Service | Miles Flown | Total Passengers Carried | Total Passenger Miles Flown | Express Carried (pounds) | Mail Pound Miles Flown <sup>1</sup> |
|------|-----------|-------------------|-------------|--------------------------|-----------------------------|--------------------------|-------------------------------------|
| 1926 | 11        | (2)               | 4,258,771   | 5,782                    | (2)                         | 3,555                    | (2)                                 |
| 1927 | 16        | 128               | 5,770,863   | 8,661                    | (2)                         | 15,850                   | (2)                                 |
| 1928 | 31        | 268               | 10,100,230  | 47,840                   | (2)                         | 210,404                  | (2)                                 |
| 1929 | 34        | 442               | 22,380,020  | 159,751                  | (2)                         | 249,034                  | (2)                                 |
| 1930 | 38        | 497               | 31,092,034  | 374,935                  | 81,014,572                  | 353,523                  | (2)                                 |
| 1931 | 35        | 490               | 42,755,417  | 499,981                  | 106,442,375                 | 788,050                  | 6,280,409,884                       |
| 1932 | 20        | 350               | 45,050,354  | 474,270                  | 127,038,798                 | 1,033,070                | 5,402,240,740                       |
| 1933 | 24        | 408               | 48,771,553  | 493,141                  | 173,402,119                 | 1,510,215                | 5,135,897,406                       |
| 1934 | 22        | 417               | 49,955,300  | 491,743                  | 187,858,029                 | 2,133,101                | 4,022,822,780                       |
| 1935 | 23        | 350               | 55,380,353  | 749,946                  | 313,095,508                 | 3,822,397                | 8,205,416,188                       |
| 1936 | 21        | 272               | 63,777,220  | 1,020,931                | 427,710,253                 | 6,958,777                | 11,482,872,022                      |
| 1937 | 17        | 282               | 60,071,507  | 1,102,707                | 470,093,165                 | 7,127,360                | 13,300,460,117                      |
| 1938 | 18        | 253               | 60,668,827  | 1,343,127                | 557,719,268                 | 7,335,067                | 14,845,710,071                      |
| 1939 | 17        | 205               | 82,571,523  | 1,870,051                | 749,787,040                 | 9,514,299                | 17,170,021,545                      |
| 1940 | 16        | 358               | 108,800,430 | 2,950,180                | 1,147,444,948               | 12,500,170               | 20,071,275,685                      |
| 1941 | 17        | 350               | 133,022,670 | 3,060,545                | 1,491,734,071               | 19,201,671               | 25,800,800,001                      |
| 1942 | 16        | 170               | 110,102,860 | 3,551,833                | 1,481,079,320               | 40,101,657               | 42,133,253,820                      |
| 1943 | 16        | 191               | 103,601,443 | 3,454,010                | 1,642,509,610               | 57,543,591               | 71,747,116,231 <sup>4</sup>         |

<sup>1</sup> Mail pound miles flown are for Domestic services and Hawaiian Airlines, Ltd., which company holds a domestic air mail contract.

<sup>2</sup> Not available prior to 1930.

<sup>3</sup> Air mail pound miles have been computed by the Post Office Department commencing with January, 1931, and are not available prior to that date.

<sup>4</sup> Estimated.

## STATUS OF AIR CARRIER OPERATIONS

Compiled by U. S. Civil Aeronautics Administration

January 1, 1944

|                                               |         |         |
|-----------------------------------------------|---------|---------|
| Route Miles Operated.....                     | 36,982  | 36,982  |
| With U. S. Mail.....                          | 36,982  |         |
| With Passengers.....                          | 34,893  |         |
| With Express.....                             | 36,982  |         |
| Airplane Miles Scheduled Daily (Average)..... | 305,084 | 305,084 |
| With U. S. Mail.....                          | 305,084 |         |
| With Passengers.....                          | 286,754 |         |
| With Express.....                             | 305,084 |         |
| Number of Services in Operation.....          | 124     | 124     |
| With U. S. Mail.....                          | 124     |         |
| With Passengers.....                          | 113     |         |
| With Express.....                             | 124     |         |
| Number of Domestic Air Carriers.....          | 16      | 16      |



# NAVIGATION

SUPPLIES    INSTRUCTION    CONSULTATION

●

## WEEMS SYSTEM OF NAVIGATION

ANNAPOLIS, MARYLAND

●

WE INVITE YOU TO SUBMIT TO US ANY IDEAS OR PROBLEMS YOU MAY HAVE RELATIVE TO NAVIGATION FOR OUR CONSIDERATION OR SOLUTION.



**SOCONY-VACUUM OIL CO., INC.**, a leader in the developing and refining of aviation fuels and oils, is proud of the part it plays to help

**"KEEP 'EM FLYING"**



**Need Trained Men Equipped for LEADERSHIP in Commercial Transport and Fixed Base Operations?**

**— Look to Parks**

In the fields of Aviation Operations Engineering, Aviation Maintenance Engineering, and Aeronautical Engineering, graduates of Parks Air College have advanced to such representative positions as these:

Meteorologist—Station Manager—Crew Chief—  
Flight Engineer—Assembly Chief—Production  
Engineer—Group Leader—Liaison Engineer

Parks trained men have a long, proven record of winning and holding positions such as these in Aviation Operations Engineering, Aviation Maintenance Engineering, and Aeronautical Engineering.

Write or wire Oliver L. Parks, President, for full information about Parks Air College and Parks graduates.

**PARKS AIR COLLEGE, INC.**

East St. Louis, Illinois

## MONTHLY AIR CARRIER OPERATIONS

Domestic Air Lines in the U. S.

Compiled by Information and Statistics Service, U. S. Civil Aeronautics Administration

| <i>1941</i>    | <i>Miles Flown</i> | <i>Passengers<sup>2</sup></i> | <i>Passenger Miles<sup>2</sup></i> | <i>Mail<sup>1</sup> Pound Miles</i> | <i>Express Pounds</i> |
|----------------|--------------------|-------------------------------|------------------------------------|-------------------------------------|-----------------------|
| January.....   | 8,946,038          | 197,854                       | 78,339,567                         | 1,761,226,024                       | 1,116,025             |
| February.....  | 8,842,795          | 218,163                       | 84,639,781                         | 1,813,348,177                       | 1,110,008             |
| March.....     | 10,017,862         | 245,924                       | 96,661,662                         | 2,018,484,815                       | 1,215,671             |
| April.....     | 10,606,486         | 308,644                       | 114,748,987                        | 2,061,880,065                       | 1,354,437             |
| May.....       | 11,738,282         | 363,954                       | 133,079,048                        | 2,105,826,655                       | 1,464,020             |
| June.....      | 11,537,883         | 380,990                       | 141,905,987                        | 2,083,030,596                       | 1,545,248             |
| July.....      | 12,178,479         | 398,434                       | 147,418,618                        | 2,212,783,024                       | 1,764,372             |
| August.....    | 12,471,701         | 447,316                       | 158,068,167                        | 2,255,207,699                       | 1,842,858             |
| September..... | 12,127,483         | 455,647                       | 158,151,061                        | 2,216,527,714                       | 1,662,284             |
| October.....   | 12,200,352         | 420,393                       | 150,919,895                        | 2,366,448,757                       | 1,760,770             |
| November.....  | 11,500,667         | 324,546                       | 115,825,169                        | 2,230,666,784                       | 1,680,093             |
| December.....  | 10,854,651         | 298,680                       | 111,076,720                        | 2,675,279,781                       | 2,385,786             |
| Total.....     | 133,022,670        | 4,060,545                     | 1,491,734,671                      | 25,800,800,091                      | 19,209,671            |
| <i>1942</i>    |                    |                               |                                    |                                     |                       |
| January.....   | 11,126,776         | 300,900                       | 113,134,990                        | 2,593,528,302                       | 2,531,162             |
| February.....  | 9,978,880          | 286,435                       | 104,219,667                        | 2,552,048,641                       | 2,169,543             |
| March.....     | 11,352,252         | 371,398                       | 130,060,782                        | 3,018,933,335                       | 2,560,255             |
| April.....     | 11,339,905         | 428,153                       | 158,217,575                        | 2,995,738,918                       | 2,883,801             |
| May.....       | 10,846,781         | 373,303                       | 146,234,958                        | 3,156,110,855                       | 3,075,985             |
| June.....      | 7,353,270          | 243,819                       | 110,301,132                        | 3,129,665,458                       | 3,096,877             |
| July.....      | 8,079,138          | 265,369                       | 117,216,147                        | 3,442,923,698                       | 3,533,980             |
| August.....    | 8,451,428          | 285,824                       | 128,429,975                        | 3,661,421,999                       | 3,926,991             |
| September..... | 8,098,555          | 275,277                       | 126,151,759                        | 3,870,283,599                       | 4,374,884             |
| October.....   | 8,407,566          | 275,063                       | 129,182,369                        | 4,334,959,342                       | 4,340,553             |
| November.....  | 7,776,768          | 242,284                       | 113,048,028                        | 4,337,909,595                       | 3,973,689             |
| December.....  | 7,291,532          | 203,948                       | 96,778,947                         | 5,038,830,078                       | 3,633,847             |
| Total.....     | 110,102,860        | 3,551,833                     | 1,481,976,329                      | 42,133,253,820                      | 40,101,657            |
| <i>1943</i>    |                    |                               |                                    |                                     |                       |
| January.....   | 7,508,260          | 208,380                       | 101,410,602                        | 4,657,982,679                       | 3,621,635             |
| February.....  | 7,585,465          | 233,049                       | 110,982,551                        | 4,927,007,419                       | 3,647,269             |
| March.....     | 8,126,495          | 265,175                       | 124,259,467                        | 5,397,639,893                       | 4,320,107             |
| April.....     | 8,288,177          | 280,913                       | 132,984,531                        | 5,728,670,986                       | 4,816,449             |
| May.....       | 8,314,154          | 282,103                       | 133,266,615                        | 5,509,952,668                       | 4,549,436             |
| June.....      | 8,410,461          | 297,760                       | 140,745,710                        | 5,551,083,875                       | 4,834,148             |
| July.....      | 8,880,864          | 320,096                       | 150,013,387                        | 6,035,702,855                       | 5,261,076             |
| August.....    | 9,303,103          | 338,059                       | 156,873,457                        | 6,390,995,706                       | 5,335,317             |
| September..... | 9,214,834          | 321,616                       | 153,980,314                        | 6,355,904,239                       | 5,384,732             |
| October.....   | 9,519,543          | 322,099                       | 155,855,938                        | 6,849,136,537                       | 5,171,289             |
| November.....  | 9,307,585          | 301,253                       | 145,104,815                        | 6,903,039,374                       | 5,109,677             |
| December.....  | 9,151,502          | 283,537                       | 137,122,253                        | 7,350,000,000 <sup>2</sup>          | 5,492,456             |
| Total.....     | 103,601,443        | 3,454,040                     | 1,642,596,640                      | 71,747,116,231 <sup>2</sup>         | 57,543,591            |

<sup>1</sup> Includes Hawaiian Airlines, Ltd.<sup>2</sup> Estimated.<sup>3</sup> Revenue and non-revenue.

# CHANDLER-EVANS CORPORATION



*AIRCRAFT CARBURETORS  
PUMPS AND PROTEK-PLUGS*

S O U T H M E R I D E N · C O N N E C T I C U T · U · S · A



## AIRLINES PREFER TEXACO

More revenue airline miles in the U. S. are flown with Texaco than with any other brand. This preference for Texaco Aviation Products, year after year, is due to the greater benefits they bring.

The Texas Company, Aviation Division, 135 East 42nd Street,  
New York 17, N. Y.

## TEXACO AVIATION PRODUCTS

## UNITED STATES AIR TRANSPORT ROUTES

Compiled by U. S. Civil Aeronautics Administration

January 1, 1944

| Routes                                                                             | Airway miles | Schedule (round trips) | Daily mileage | Operator                    |
|------------------------------------------------------------------------------------|--------------|------------------------|---------------|-----------------------------|
| DOMESTIC                                                                           |              |                        |               |                             |
| Pittsburgh-Huntington via Elkins and Charleston.....                               | 316          | 1 time daily...        | 632           | All American Aviation, Inc. |
| Pittsburgh-Wilmington.....                                                         | 381          | 1 time daily...        | 762           | "                           |
| Pittsburgh-Huntington via Parkersburg.....                                         | 309          | 1 time daily...        | 618           | "                           |
| Pittsburgh-Williamsport.....                                                       | 202          | 2 times daily...       | 808           | "                           |
| Pittsburgh-Jamestown.....                                                          | 178          | 2 times daily...       | 712           | "                           |
| New York-Washington.....                                                           | 215          | 3 times daily...       | 1,260         | American Airlines, Inc.     |
| New York-Los Angeles via Washington, Nashville, Memphis, Dallas or Fort Worth..... | 2,703        | 3 times daily...       | 10,218        | "                           |
| New York-Los Angeles via Washington, Nashville, Little Rock and Big Spring.....    | 2,739        | 1 time daily...        | 5,478         | "                           |
| New York-Los Angeles via Washington, Nashville, Dallas or Fort Worth.....          | 2,745        | 2 times daily...       | 10,980        | "                           |
| Dallas-Los Angeles.....                                                            | 1,350        | 1 time daily...        | 2,700         | "                           |
| New York-Chicago via Buffalo and Detroit.....                                      | 761          | 6 times daily...       | 9,132         | "                           |
| New York-Chicago via Buffalo, Detroit and South Bend.....                          | 772          | 1 time daily...        | 1,544         | "                           |
| New York-Buffalo via Syracuse.....                                                 | 328          | 1 time daily...        | 656           | "                           |
| New York-Cleveland via Syracuse and Buffalo.....                                   | 521          | 1 time daily...        | 1,042         | "                           |
| New York-Buffalo (direct).....                                                     | 292          | 1 time daily...        | 584           | "                           |
| Detroit-Chicago via South Bend.....                                                | 251          | 1 time daily...        | 502           | "                           |
| Detroit-Chicago (direct).....                                                      | 247          | 1 time daily...        | 494           | "                           |
| Boston-New York via Hartford and Providence.....                                   | 204          | 1 time daily...        | 408           | "                           |
| Boston-New York via Hartford.....                                                  | 186          | 5 times daily...       | 1,860         | "                           |
| Boston-New York via Providence.....                                                | 192          | 4 times daily...       | 1,536         | "                           |
| Washington-Chicago via Cincinnati.....                                             | 662          | 3 times daily...       | 3,972         | "                           |
| Washington-Chicago via Elkins, Huntington and Cincinnati.....                      | 682          | 1 time daily...        | 1,364         | "                           |
| Cleveland-Nashville via Cincinnati.....                                            | 488          | 2 times daily...       | 1,952         | "                           |
| Cincinnati-Dayton.....                                                             | 56           | 2 times daily...       | 224           | "                           |
| Chicago-Fort Worth via St. Louis and Oklahoma City.....                            | 924          | 2 times daily...       | 3,696         | "                           |
| Nashville-Memphis.....                                                             | 200          | 2 times daily...       | 800           | "                           |
| El Paso-Los Angeles.....                                                           | 743          | 1 time daily...        | 1,486         | "                           |
| Fort Worth-Laredo.....                                                             | 304          | 1 time daily...        | 788           | "                           |
| Chicago-Brownsville via Kansas City, Dallas and San Antonio.....                   | 1,378        | 1 time daily...        | 2,756         | Braniff Airways, Inc.       |
| Chicago-Houston via Kansas City and Dallas.....                                    | 1,130        | 2 times daily...       | 4,520         | "                           |
| Chicago-Corpus Christi via Kansas City and Dallas.....                             | 1,312        | 1 time daily...        | 2,624         | "                           |
| Dallas-Laredo.....                                                                 | 495          | 1 time daily...        | 810           | "                           |
| Dallas-San Antonio.....                                                            | 255          | 1 time daily...        | 510           | "                           |
| Denver-Dallas via Amarillo.....                                                    | 706          | 1 time daily...        | 1,412         | "                           |
| Chicago-New Orleans via St. Louis.....                                             | 857          | 2 times daily...       | 3,428         | Chicago & Southern Airlines |
| Chicago-Memphis.....                                                               | 508          | 2 times daily...       | 2,032         | "                           |
| Memphis-Houston.....                                                               | 526          | 1 time daily...        | 1,052         | "                           |
| Denver-El Paso via Pueblo and Albuquerque.....                                     | 578          | 1 time daily...        | 1,156         | Continental Air Lines, Inc. |



## War and Peace

Tributes to ground crews on the fighting fronts show how America has depended on its trained aircraftsmen in waging modern war. When peace comes, they will be needed to help maintain our flag in first place on the world's airways.

ACADEMY OF AERONAUTICS

La Guardia Field, N. Y.

CASEY JONES SCHOOL OF AERONAUTICS

Newark, N. J.

# HYDRAULIC FLUIDS

for  
*Airplanes*



## THE BELL COMPANY

INCORPORATED

411-15 N. WOLCOTT, CHICAGO, ILL.



# BARR

## SERVICE



*29 Years* OF CONTINUOUS SERVICE  
TO THE AIRPLANE EXPORT TRADE

\*\*\*\*\*  
INTERNATIONAL SHIPPING AGENTS

\*\*\*\*\*  
*Complete Facilities Arranging, Dismantling, Boxing,  
Forwarding, All Risk Insurance*

### BARR SHIPPING COMPANY

HARRY K. BARR, *President*

25 BROADWAY NEW YORK

Cable Address: BARRSHIPCO



## United States Air Transport Routes (January 1, 1944)—Continued

| Routes                                                          | Airway miles | Schedule (round trips) | Daily mileage | Operator                       |
|-----------------------------------------------------------------|--------------|------------------------|---------------|--------------------------------|
| Denver-El Paso via Roswell and Carlsbad.....                    | 846          | 1 time daily..         | 1,692         | Continental Air Lines, Inc.    |
| Denver-Tulsa.....                                               | 650          | 1 time daily..         | 1,300         | "                              |
| Wichita-Tulsa.....                                              | 126          | 1 time daily..         | 252           | "                              |
| Atlanta-Cincinnati via Knoxville...                             | 380          | 2 times daily..        | 1,520         | Delta Air Corporation          |
| Atlanta-Savannah.....                                           | 251          | 1 time daily..         | 502           | "                              |
| Atlanta-Charleston.....                                         | 301          | 1 time daily..         | 602           | "                              |
| Atlanta-Fort Worth via Jackson and Shreveport.....              | 772          | 2 times daily..        | 3,088         | "                              |
| Atlanta-Fort Worth via Monroe...                                | 783          | 1 time daily..         | 1,566         | "                              |
| New Orleans-Fort Worth.....                                     | 497          | 1 time daily..         | 994           | "                              |
| New York-Miami via Orlando.....                                 | 1,229        | 1 time daily..         | 2,458         | Eastern Air Lines, Inc.        |
| New York-Miami via Washington, Charleston and Jacksonville..... | 1,188        | 4 times daily..        | 9,504         | "                              |
| New York-Miami via Washington and Jacksonville.....             | 1,185        | 1 time daily..         | 2,370         | "                              |
| New York-Brownsville via Atlanta and New Orleans.....           | 1,815        | 1 time daily..         | 3,630         | "                              |
| New York-Houston via Washington, Atlanta and New Orleans...     | 1,540        | 1 time daily..         | 3,080         | "                              |
| New York-San Antonio via Washington and Atlanta.....            | 1,805        | 1 time daily..         | 3,610         | "                              |
| New York-New Orleans via Washington and Atlanta.....            | 1,299        | 1 time daily..         | 2,598         | "                              |
| New York-Tampa via Atlanta.....                                 | 1,207        | 1 time daily..         | 2,414         | "                              |
| Chicago-Miami via Nashville and Jacksonville.....               | 1,262        | 3 times daily..        | 7,572         | "                              |
| Denver-Great Falls.....                                         | 609          | 1 time daily..         | 1,338         | Inland Air Lines, Inc.         |
| Cheyenne-Denver.....                                            | 96           | 1 time daily..         | 192           | "                              |
| Cheyenne-Huron.....                                             | 558          | 1 time daily..         | 1,116         | "                              |
| Minneapolis - Kansas City via Omaha.....                        | 577          | 3 times daily..        | 3,462         | Mid - Continent Airlines, Inc. |
| Minneapolis-St. Louis via Des Moines.....                       | 512          | 1 time daily..         | 1,024         | "                              |
| Des Moines-Tulsa via Kansas City                                | 389          | 1 time daily..         | 778           | "                              |
| Kansas City-Tulsa.....                                          | 215          | 1 time daily..         | 430           | "                              |
| New Orleans-Miami via Tampa...                                  | 915          | 3 times daily..        | 5,490         | National Air Lines, Inc.       |
| New Orleans-Jacksonville.....                                   | 511          | 1 time daily..         | 1,022         | "                              |
| Boston-Presque Isle.....                                        | 353          | 2 times daily..        | 1,412         | Northeast Air Lines, Inc.      |
| Boston-Bangor.....                                              | 204          | 2 times daily..        | 816           | "                              |
| Bangor-Moncton.....                                             | 221          | 2 times daily..        | 884           | "                              |
| Chicago-Seattle via Minneapolis and Helena.....                 | 1,808        | 1 time daily..         | 3,616         | Northwest Air Lines, Inc.      |
| Chicago-Seattle via Minneapolis and Butte.....                  | 1,822        | 1 time daily..         | 3,644         | "                              |
| Chicago-Seattle via Minneapolis and Great Falls.....            | 1,982        | 1 time daily..         | 3,964         | "                              |
| Chicago-Minneapolis (direct).....                               | 350          | 1 time daily..         | 700           | "                              |
| Chicago-Minneapolis via Rochester.                              | 357          | 1 time daily..         | 714           | "                              |
| Chicago-Minneapolis via Milwaukee                               | 379          | 1 time daily..         | 758           | "                              |
| Chicago-Fargo.....                                              | 618          | 1 time daily..         | 1,236         | "                              |
| Minneapolis-Duluth.....                                         | 145          | 1 time daily..         | 290           | "                              |
| Norfolk-Detroit via Washington and Pittsburgh.....              | 557          | 3 times daily..        | 3,342         | Pennsylvania-Central Airlines  |
| Norfolk-Pittsburgh.....                                         | 329          | 1 time daily..         | 658           | "                              |
| Washington-Detroit via Pittsburgh.                              | 421          | 4 times daily..        | 3,368         | "                              |
| Cleveland-Detroit.....                                          | 91           | 1 time daily..         | 182           | "                              |
| Washington-Pittsburgh.....                                      | 186          | 1 time daily..         | 372           | "                              |
| Pittsburgh-Buffalo.....                                         | 215          | 1 time daily..         | 430           | "                              |
| Detroit-Milwaukee.....                                          | 260          | 1 time daily..         | 520           | "                              |



## Hatching a War-Bird

**T**HE majority of those who use and respect Kollsman aircraft instruments know them most intimately as sentinels on the airplane instrument panel, indispensable to the plane's precise and dependable operation.

But long before our war-birds ever get into service, many engineers certify their design and performance

with Kollsman instruments in wind tunnels, engine test cells and in test flights.

Because of their accuracy, standard Kollsman instruments are found in frequent use for many forms of aeronautical experiment and in production testing. In addition, many special Kollsman instruments have been developed for these uses.

## KOLLSMAN AIRCRAFT INSTRUMENTS

PRODUCT OF

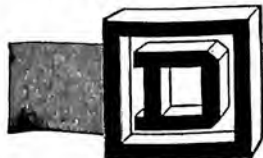

**SQUARE D COMPANY**

ELMHURST, NEW YORK

• GLENDALE, CALIFORNIA



## United States Air Transport Routes (January 1, 1944)—Continued

| Routes                                                                            | Airway miles | Schedule (round trips) | Daily mileage | Operator                         |
|-----------------------------------------------------------------------------------|--------------|------------------------|---------------|----------------------------------|
| Pittsburgh-Birmingham via Knoxville.....                                          | 620          | 1 time daily...        | 1,258         | Pennsylvania-Central Airlines    |
| New York-Los Angeles via Pittsburgh, Chicago, Kansas City and Winslow.....        | 2,572        | 2 times daily..        | 10,288        | Transcontinental and Western Air |
| New York-Los Angeles via Pittsburgh, Chicago, Kansas City and Phoenix.....        | 2,663        | 2 times daily..        | 10,652        |                                  |
| New York-San Francisco via Pittsburgh, Chicago, Kansas City and Boulder City..... | 3,012        | 1 time daily..         | 6,024         |                                  |
| New York-San Francisco via Pittsburgh, Chicago, Kansas City and Los Angeles.....  | 2,897        | 1 time daily..         | 5,794         | "                                |
| New York-Chicago via Pittsburgh and Dayton.....                                   | 822          | 1 time daily...        | 1,644         | "                                |
| New York-Dayton via Pittsburgh..                                                  | 575          | 1 time daily..         | 1,150         | "                                |
| New York-Kansas City via Dayton and St. Louis.....                                | 1,171        | 2 times daily..        | 4,684         | "                                |
| Washington-Kansas City via Dayton.....                                            | 962          | 1 time daily...        | 1,924         | "                                |
| Washington-Los Angeles via Dayton, St. Louis and Boulder City..                   | 2,418        | 1 time daily...        | 4,836         | "                                |
| Detroit-Cincinnati.....                                                           | 242          | 3 times daily..        | 1,452         | "                                |
| Washington-Pittsburgh.....                                                        | 186          | 2 times daily..        | 744           | "                                |
| New York-Chicago via Cleveland..                                                  | 725          | 4 times daily..        | 5,800         | United Air Lines, Inc.           |
| New York-Chicago via Philadelphia and Toledo.....                                 | 765          | 2 times daily..        | 3,060         | "                                |
| New York-Chicago via Youngstown                                                   | 728          | 1 time daily...        | 1,456         | "                                |
| New York-Chicago via Akron.....                                                   | 726          | 1 time daily...        | 1,452         | "                                |
| Washington-Chicago via Toledo..                                                   | 737          | 1 time daily...        | 1,474         | "                                |
| Chicago-San Francisco via Omaha, Denver, Salt Lake City and Reno                  | 610          | 2 times daily..        | 2,440         | "                                |
| Chicago-San Francisco via Des Moines, Omaha and Denver.....                       | 1,918        | 2 times daily..        | 7,672         | "                                |
| Chicago-San Francisco via Omaha, Denver, Salt Lake City and Reno                  | 1,001        | 1 time daily...        | 3,802         | "                                |
| Chicago-San Francisco via Des Moines, Omaha, and Cheyenne..                       | 1,889        | 1 time daily...        | 3,778         | "                                |
| Chicago-San Francisco via Omaha, Cheyenne and Salt Lake City...                   | 1,859        | 1 time daily...        | 3,718         | "                                |
| Chicago-Salt Lake City via Denver.                                                | 1,004        | 1 time daily...        | 3,808         | "                                |
| Chicago-Salt Lake City via Cheyenne.....                                          | 1,289        | 1 time daily...        | 2,578         | "                                |
| Chicago-Seattle via Rock Springs and Boise.....                                   | 1,263        | 1 time daily...        | 2,526         | "                                |
| Chicago-Seattle via Denver and Salt Lake City.....                                | 2,015        | 1 time daily...        | 4,030         | "                                |
| Seattle-Los Angeles via Sacramento and San Francisco.....                         | 2,094        | 1 time daily...        | 4,188         | "                                |
| Seattle-Los Angeles via Medford and San Francisco.....                            | 1,042        | 2 times daily..        | 4,168         | "                                |
| Seattle-Los Angeles via San Francisco and Bakersfield.....                        | 1,027        | 1 time daily...        | 2,054         | "                                |
| San Francisco-Los Angeles via Oakland.....                                        | 1,045        | 1 time daily...        | 2,090         | "                                |
| San Francisco-Los Angeles via Oakland and Bakersfield.....                        | 338          | 1 time daily...        | 676           | "                                |
| San Francisco-Los Angeles via Santa Barbara.....                                  | 354          | 1 time daily...        | 708           | "                                |
|                                                                                   | 352          | 1 time daily...        | 704           | "                                |

# LINK

**Oldest and largest manufacturer  
of training devices to promote  
the safety of flight.**



**LINK TRAINER • VISUAL TRAINER  
CELESTIAL NAVIGATION TRAINER  
AVIATION OCTANT • STAR GLOBE  
COLLIMATOR • HYDRO TRAINER  
MAP READING TRAINER**



**LINK AVIATION DEVICES, INC.**

**BINGHAMTON, N. Y.**

**J. V. W. & CO., INTERNATIONAL DISTRIBUTORS  
1100 RAYMOND BOULEVARD, NEWARK 5, N. J.**

---

---

## FLYING FACTS AND FIGURES

United States Air Transport Routes (January 1, 1944)—Continued

| Routes                                    | Airway miles | Schedule (round trips) | Daily mileage | Operator                |
|-------------------------------------------|--------------|------------------------|---------------|-------------------------|
| San Francisco-Los Angeles (direct)        | 327          | 2 times daily          | 1,308         | United Air Lines, Inc.  |
| Sacramento-San Francisco                  | 70           | 2 times daily          | 316           | "                       |
| Seattle-Portland                          | 135          | 2 times daily          | 540           | "                       |
| San Diego-Los Angeles                     | 123          | 2 times daily          | 492           | "                       |
| Lethbridge-Salt Lake City via Great Falls | 645          | 1 time daily           | 1,290         | Western Air Lines, Inc. |
| Salt Lake City-Los Angeles                | 590          | 4 times daily          | 4,720         | "                       |
| Los Angeles-San Diego                     | 123          | 3 times daily          | 738           | "                       |
| Total Domestic Routes                     | 36,982       |                        | 305,084       |                         |

## U. S. DOMESTIC AIR CARRIER OPERATIONS

And Accident Statistics for the Calendar Years 1941, 1942, and 1943

Compiled by Information and Statistics Service, U. S. Civil Aeronautics Administration

|                                              | 1941          | 1942          | 1943          |
|----------------------------------------------|---------------|---------------|---------------|
| Miles Flown                                  | 133,022,679   | 110,102,860   | 103,601,443   |
| Total Passengers Carried                     | 4,060,545     | 3,551,833     | 3,454,040     |
| Total Passenger Miles                        | 1,491,734,671 | 1,481,976,329 | 1,642,596,640 |
| Fatal Accidents                              | 4             | 5             | 2             |
| Passenger Fatalities                         | 35            | 55            | 22*           |
| Crew Fatalities                              | 9             | 16            | 7*            |
| Miles Flown per Fatal Accident               | 33,255,670    | 22,020,572    | 51,800,722    |
| Passenger Miles Flown per Passenger Fatality | 42,620,991    | 26,814,248    | 74,663,484    |
| Miles Flown per Crew Fatality                | 14,780,298    | 6,881,429     | 14,800,206    |

\* One dead-head pilot is not included in either the crew or the passenger fatality.

Altimeters  
 Suction Gauges  
 Airspeed Indicators  
 Manifold Pressure Gauges  
 Bimetal Strut Thermometers  
 Motor Coolant Thermometers  
 Gun Firing Mechanism Gauges  
 Oil Temperature Thermometers  
 Carburetor Temperature Thermometers

## AIRCRAFT INSTRUMENTS

U.S.

De-Icer Gauges  
 Heating System Gauges  
 Engine Gauge Units  
 Oil Pressure Gauges  
 Air Pressure Gauges  
 Landing Gear Gauges  
 Fuel Quantity Gauges  
 Fuel Pressure Gauges  
 Ice Warning Indicators

U.S.

UNITED STATES  
GAUGE COMPANY,

14 WALL ST., NEW YORK, N.Y.

*Clarke-Aero*  
**HYDRAULIC COMPONENTS  
FOR AIRCRAFT**

Gun Turret Control Valves  
 Hydraulic Motors ★ Fuel  
 Transfer Pumps ★ Restrictor  
 Valves ★ Relief Valves ★ Ro-  
 tary Valves (rotor type and  
 split sleeve type) ★ Shuttle  
 Valves ★ Gun Elevator Cylin-  
 ders ★ Gill Cylinders.

**CLARKE AERO-HYDRAULICS INC.**  
PASADENA, CALIFORNIA

FROM

STAINLESS  
ALUMINUM

ALL STEELS  
TOBIN BRONZE

We manufacture precision screw machine products special and standard Army-Navy specifications exclusively for the AIRCRAFT INDUSTRY.

**AIRCRAFT HARDWARE  
MFG. Co.**

1381 Lafayette Avenue  
New York, N. Y.

## TIP-OFF ON TOMORROW'S TAKE-OFF!

Watch Aeronca for a preview of post-war private flying! Builder of better light planes long before the war, Aeronca today is producing observation planes for the Army Air Forces . . . and sturdy training planes for army fledglings which teach them how and teach them fast. Delicate on controls, the Army's L-3-B . . . made by Aeronca, handles with such maneuverability in completing its daily vital missions . . . sometimes under almost impossible conditions . . . that enthusiastic airmen fondly dubbed it "Grasshopper". ☆ ☆ ☆ Aeronca's ever-growing engineering skill and experience point to even greater safety and simplicity in tomorrow's take-offs, flying, landings . . . with the Grasshopper, "First and Finest". ☆ ☆ ☆ ☆ ☆



**AERONCA AIRCRAFT CORPORATION**

M I D D L E T O W N , O H I O



*Manufacturers of*

*Control Devices*

*and Components . . . for  
Electric, Electronic and  
Mechanical Applications*

**EASTERN AIR  
DEVICES, INC.**

**585 DEAN STREET  
BROOKLYN 17, N. Y.**

*An Affiliate of  
The Fred Goat Co., Inc., Est. 1893*

**SINCE 1932**

- Welded Tubular Assemblies
- Fabricated Alloy Steel Parts and Drop Forgings
- ● ● for AIRCRAFT

*Designers  
Engineers  
Manufacturers*

**AIRCRAFT MECHANICS, Inc.**  
Colorado Springs, Colorado



## CAVU

The CAP has proved what light civilian planes can do, has written "ceiling and visibility unlimited" on their future.

In flying jeeps they've assisted big flying boats in rescues at sea. Pinch-hitting for bombers, they've smashed subs. They've flown critical cargoes, and coaxed flyweight airplanes through missions that seemed impossible.

At Standard of California, too, we're lifting performance ceilings for John Citizen's post-war aircraft. Our new aviation fuels and lubricants will help give light airplanes far more spirit, stamina, economy — and help to change a week-end sport to a way of living.



**STANDARD OF CALIFORNIA**

## PROGRESS OF CIVIL AERONAUTICS IN THE UNITED STATES

(All statistics are as of Dec. 31 each year)

Compiled by Information and Statistics Service, U. S. Civil Aeronautics Administration

|                                                                 | 1941          | 1942          | 1943                |
|-----------------------------------------------------------------|---------------|---------------|---------------------|
| <b>DOMESTIC AIR-CARRIER OPERATIONS</b>                          |               |               |                     |
| Operators (number of).....                                      | 17            | 16            | 16                  |
| Airplanes (in service and reserve).....                         | 359           | 179           | 194                 |
| Air-carrier route mileage (unduplicated).....                   | 47,793        | 36,442        | 36,982              |
| Express service.....                                            | 47,793        | 36,442        | 36,982              |
| Mail service.....                                               | 45,454        | 35,641        | 36,982              |
| Passenger service.....                                          | 47,793        | 35,168        | 34,893              |
| Miles flown:                                                    |               |               |                     |
| Daily average.....                                              | 364,446       | 301,652       | 283,840             |
| Revenue miles.....                                              | 133,922,679   | 110,102,860   | 103,601,443         |
| Passenger traffic:                                              |               |               |                     |
| Passengers carried.....                                         | 4,060,545     | 3,551,833     | 3,454,040           |
| Revenue <sup>2</sup> .....                                      | 3,768,892     | 3,349,134     | 3,351,537           |
| Nonrevenue.....                                                 | 291,653       | 202,699       | 102,503             |
| Passenger miles flown (1 passenger carried 1 mile):.....        | 1,401,734,671 | 1,481,976,329 | 1,642,506,640       |
| Revenue.....                                                    | 1,300,584,231 | 1,398,042,146 | 1,606,119,468       |
| Nonrevenue.....                                                 | 122,150,440   | 83,934,183    | 36,477,172          |
| Passenger seat miles flown.....                                 | 2,310,205,507 | 1,937,672,755 | 1,824,849,802       |
| Passenger load factor (per cent):                               |               |               |                     |
| Revenue.....                                                    | 59.13         | 72.15         | 88.01               |
| Revenue and nonrevenue.....                                     | 64.40         | 76.11         | 90.01               |
| Passenger fare per mile.....                                    | \$0.0503      | \$0.0527      | ....                |
| Mail:                                                           |               |               |                     |
| Ton miles <sup>3</sup> .....                                    | 12,900,405    | 21,066,627    | 35,873,558          |
| Express and freight:                                            |               |               |                     |
| Ton miles.....                                                  | 5,242,529     | 11,717,605    | 15,117,925          |
| Pounds <sup>2</sup> .....                                       | 19,209,671    | 40,101,657    | 57,543,591          |
| Accidents:                                                      |               |               |                     |
| Number of accidents.....                                        | 33            | 31            | 24                  |
| Miles flown per accident.....                                   | 4,030,990     | 3,551,705     | 4,316,727           |
| Number of fatal accidents.....                                  | 4             | 5             | 2                   |
| Miles flown per fatal accident.....                             | 33,255,670    | 22,020,572    | 51,800,722          |
| Fatal accidents per 1,000,000 miles flown.....                  | 0.03          | 0.05          | 0.02                |
| Pilot fatalities.....                                           | 3             | 5             | 2                   |
| Miles flown per pilot fatality.....                             | 44,340,893    | 22,020,572    | 51,800,722          |
| Copilot fatalities.....                                         | 3             | 5             | 2                   |
| Crew fatalities (other than pilot and copilot).....             | 3             | 6             | 3                   |
| Passenger fatalities.....                                       | 35            | 55            | 22                  |
| Passenger miles flown per passenger fatality.....               | 46,620,991    | 26,945,024    | 74,663,484          |
| Passenger fatalities per 100,000,000 passenger miles flown..... | 2.35          | 3.71          | 1.34                |
| Ground crew and third party fatalities.....                     | 0             | 0             | 0                   |
| Total fatalities.....                                           | 44            | 71            | 30 <sup>4</sup>     |
| Fatalities per 1,000,000 miles flown.....                       | 0.33          | 0.64          | 0.29                |
| <b>PRIVATE FLYING OPERATIONS</b><br>(All domestic)              |               |               |                     |
| Airplanes in operation (certificated and uncertificated).....   | 24,124        | 22,329        | 22,323 <sup>1</sup> |
| <b>AIRPORTS AND LANDING FIELDS</b>                              |               |               |                     |
| Airports and landing fields:                                    |               |               |                     |
| Total airports in operation.....                                | 2,484         | 2,809         | 2,769               |



## Take Test Flights on the Ground with HydroILic Test Stands



The flight performance of many of the most vital functional parts of an airplane can now be accurately ground tested with Denison HydroILic Test Stands.

Three typical test stands are shown at left. One checks spark plugs for electrical leaks . . . another tests magnetos at almost any temperature, speed, air pressure or humidity encountered in flight . . . the third checks vital hydraulic systems to make sure that ailerons, rudders, brakes, bomb bay doors, landing gear, and propeller controls will function efficiently. For further details on these and other applications of HydroILics, write us.

THE DENISON ENGINEERING CO.  
1187 DUBLIN RD., COLUMBUS 16, OHIO



**DENISON**  
EQUIPMENT *in* APPLIED  
*HydroILics*

**AERO of Corry**  
PRECISION AIRCRAFT PARTS SINCE 1916

Designers and manufacturers of precision aircraft parts and accessories such as Fuel Valves, Fuel Pumps, Engine Controls, Fuel Strainers and A/N Hardware

AERO SUPPLY MFG. CO. INC.  
Corry, PA.



DESIGNERS ENGINEERS  
MANUFACTURERS

RUBBER PRODUCTS  
FOR THE  
AIRCRAFT INDUSTRY  
WRITE FOR CATALOG

COMPLETE LINE  
A. N. GROMMETS

BUMPERS - RINGS  
BUSHINGS - MOLDS  
EXTRUSIONS - SLAB  
GASKETS - SHEET  
WASHERS - SPRING  
TUBING - SPONGE  
SPECIAL PARTS

THOUSANDS OF PARTS  
AVAILABLE FROM  
STOCK OR FROM  
OUR STOCK MOLDS  
SEND US YOUR  
INQUIRIES

All Phones  
HAYMARKET 7093



ATLANTIC INDIA RUBBER WORKS, INC.  
1453 WEST VAN BUREN STREET - CHICAGO, ILLINOIS.

## PROGRESS OF CIVIL AERONAUTICS IN THE UNITED STATES

—Continued—

|                                                                                          | 1941    | 1942    | 1943                |
|------------------------------------------------------------------------------------------|---------|---------|---------------------|
| <b>AIRPORTS AND LANDING FIELDS (Continued)</b>                                           |         |         |                     |
| Commercial.....                                                                          | 930     | 1,069   | 801                 |
| Municipal.....                                                                           | 1,086   | 1,129   | 911                 |
| Intermediate CAA—lighted.....                                                            | 283     | 273     | 239 <sup>6</sup>    |
| Intermediate CAA—unlighted.....                                                          | 0       | 0       | 1                   |
| Army, Navy, Marine Corps, National Guard,<br>reserve, private and miscellaneous airports | 185     | 338     | 814                 |
| Lighted, total.....                                                                      | 662     | 700     | 525                 |
| <b>FEDERAL AIRWAYS SYSTEM AND AIDS<br/>TO AIR NAVIGATION</b>                             |         |         |                     |
| Federal airways:                                                                         |         |         |                     |
| Mileage.....                                                                             | 32,670  | 33,497  | 33,403              |
| Mileage under construction at close of year.....                                         | 780     | 1,393   | 1,493               |
| Communications:                                                                          |         |         |                     |
| Total Radio range stations.....                                                          | 312     | 280     | 291                 |
| Radio range stations with scheduled broad-<br>casts.....                                 | 111     | 105     | 108                 |
| Radio range stations with nonscheduled<br>broadcasts.....                                | 180     | 150     | 166                 |
| Radio range stations without voice.....                                                  | 12      | 10      | 17                  |
| Radio marker beacons.....                                                                | 18      | 10      | 63                  |
| Weather reporting airway and airport stations:                                           |         |         |                     |
| Weather Bureau and CAA operated long-<br>line teletypewriter equipped.....               | 453     | 442     | 395                 |
| Traffic control stations teletypewriter<br>equipped.....                                 | 130     | 20      | 36                  |
| Miles of weather reporting teletypewriter<br>service.....                                | 55,268  | 52,618  | 52,800              |
| Miles of traffic control teletypewriter service.....                                     | 12,621  | 9,008   | 10,372              |
| Weather Bureau—first order stations (does<br>not include airport stations).....          | 130     | 135     | 120                 |
| Airway lighting:                                                                         |         |         |                     |
| Beacons:                                                                                 |         |         |                     |
| Revolving.....                                                                           | 2,110   | 2,080   | 2,035               |
| Flashing.....                                                                            | 164     | 141     | 143                 |
| Beacons—privately owned and certified.....                                               | 752     | 1,041   | 1,201               |
| Intermediate landing fields, lighted.....                                                | 270     | 207     | 236                 |
| <b>CERTIFICATES</b>                                                                      |         |         |                     |
| Certificated aircraft:                                                                   |         |         |                     |
| Airplanes.....                                                                           | 21,836  | 22,001  | 22,927 <sup>1</sup> |
| Gliders.....                                                                             | 65      | 104     | 124                 |
| Certificated airmen:                                                                     |         |         |                     |
| Pilots, airplane, total.....                                                             | 100,787 | 110,510 | 122,884             |
| Airline transport.....                                                                   | 1,587   | 2,177   | 2,315               |
| Commercial.....                                                                          | 15,420  | 18,808  | 20,587              |
| Private.....                                                                             | 83,771  | 89,525  | 99,982              |
| Pilots, glider.....                                                                      | 100     | 211     | 1,435               |
| Mechanics.....                                                                           | 14,947  | 18,097  | 20,803 <sup>5</sup> |
| Parachute riggers.....                                                                   | 618     | 1,004   | 1,637 <sup>6</sup>  |
| Ground instructors.....                                                                  | 4,815   | 7,604   | 12,739              |



ESTABLISHED 1929

**AVIATION'S MOST DISTINGUISHED  
SCHOOL OF AERONAUTICS**

*Specializing in*

**SUPERIOR AND PROVEN TRAINING**

*in*

**AERONAUTICAL ENGINEERING**

*and*

**MASTER AVIATION MECHANICS**

**«CURTISS  
TECHNICAL**



**WRIGHT  
INSTITUTE»**

MAJOR C. C. MOSELEY, PRESIDENT AND FOUNDER  
GRAND CENTRAL AIR TERMINAL  
GLENDALE 1, (LOS ANGELES CO.) CALIFORNIA

★

CONTRACTOR TO U. S. ARMY AIR FORCES

## PROGRESS OF CIVIL AERONAUTICS IN THE UNITED STATES

—Continued—

|                                             | 1941   | 1942    | 1943    |
|---------------------------------------------|--------|---------|---------|
| CERTIFICATES (Continued)                    |        |         |         |
| Student pilot certificates issued (yearly): |        |         |         |
| Airplane.....                               | 93,366 | 139,289 | 189,102 |
| Glider.....                                 | 385    | 486     | 1,137   |

<sup>1</sup> Includes DPC aircraft assigned by CAA to WTS operators.

<sup>2</sup> Totals shown for passengers and express carried are not unduplicated figures, as the same passengers and express may be counted for more than one route.

<sup>3</sup> The mail pound miles flown by Hawaiian Airlines, Ltd., are included with the domestic mail pound miles as this company holds a domestic air mail contract. All other operations statistics for this carrier are included with foreign and territorial statistics.

<sup>4</sup> Includes 1 "deadhead" pilot not carried above.

<sup>5</sup> Includes 473 Parachute Technicians.

<sup>6</sup> Includes 3 fields which were constructed but not commissioned on Jan. 1, 1944.

## AIRCRAFT LABOR STATISTICS

Average Weekly Hours, Average Hourly Earnings, and Average Weekly Earnings of Wage Earners in the Aircraft Manufacturing Industry by Months, January 1943 to December 1943, Inclusive, Based on Reports by Cooperating Establishments.

Source: U. S. Bureau of Labor Statistics.

| 1943           | Aircraft and Parts Excluding Aircraft Engines |                      |                                 | Aircraft Engines        |                      |                                 |
|----------------|-----------------------------------------------|----------------------|---------------------------------|-------------------------|----------------------|---------------------------------|
|                | Average Weekly Earnings                       | Average Weekly Hours | Average Hourly Earnings (cents) | Average Weekly Earnings | Average Weekly Hours | Average Hourly Earnings (cents) |
| January.....   | \$46.94                                       | 46.5                 | 101.0                           | \$60.19                 | 48.2                 | 125.0                           |
| February.....  | 47.12                                         | 46.2                 | 101.9                           | 60.07                   | 48.3                 | 124.3                           |
| March.....     | 47.29                                         | 46.2                 | 102.5                           | 60.82                   | 48.8                 | 124.7                           |
| April.....     | 49.69                                         | 47.3                 | 105.2                           | 60.02                   | 48.3                 | 124.3                           |
| May.....       | 49.67                                         | 46.8                 | 106.3                           | 61.16                   | 48.8                 | 125.2                           |
| June.....      | 49.78                                         | 46.5                 | 107.0                           | 58.66                   | 46.3                 | 126.6                           |
| July.....      | 48.76                                         | 45.6                 | 107.3                           | 58.77                   | 46.1                 | 127.5                           |
| August.....    | 49.26                                         | 46.1                 | 107.0                           | 59.18                   | 46.7                 | 126.2                           |
| September..... | 52.56                                         | 46.7                 | 112.5                           | 61.14                   | 47.2                 | 129.5                           |
| October.....   | 52.40                                         | 46.8                 | 111.5                           | 60.63                   | 47.6                 | 127.5                           |
| November.....  | 52.42                                         | 46.9                 | 112.0                           | 60.75                   | 47.5                 | 127.8                           |
| December.....  | 51.52                                         | 45.9                 | 112.3                           | 57.47                   | 45.3                 | 126.8                           |

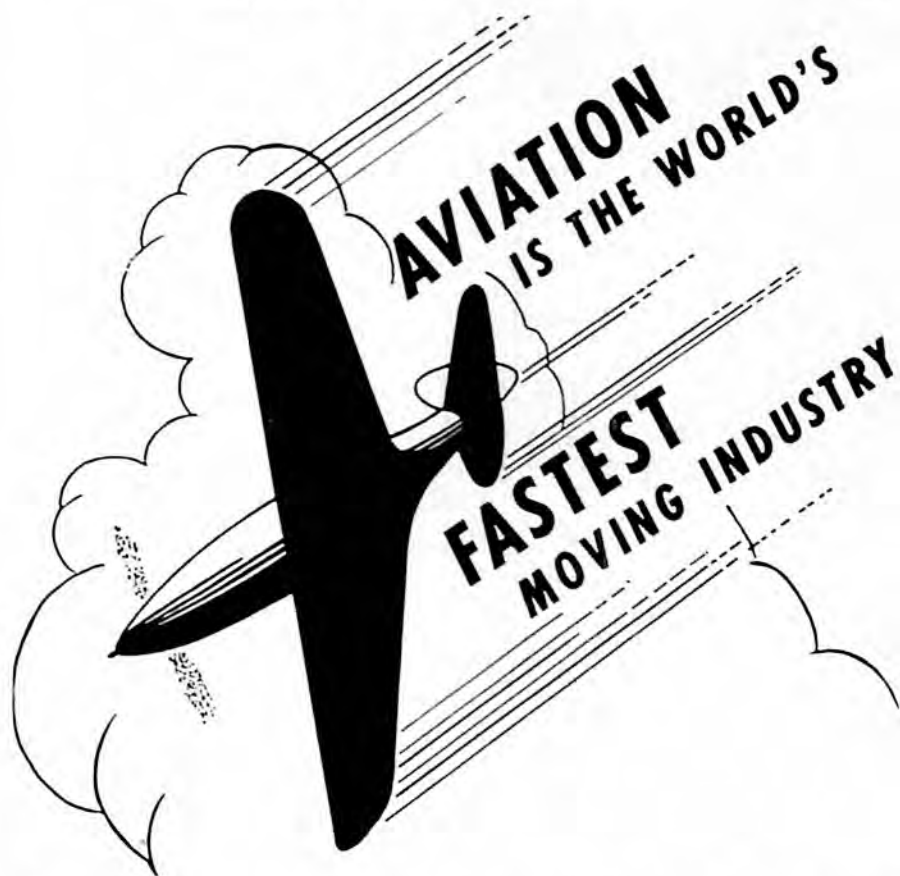

*Speed up your future by preparing for it now!*

# **Roosevelt Aviation School**

*Accredited by the U.S. Civil Aeronautics Board. Licensed by the State of New York.*

*At Roosevelt Field*

**Mineola, Long Island, New York**

**AVIATION TRAINING AT ITS BEST • WRITE FOR COMPLETE INFORMATION**

AMERICAN AIRPLANES IN SERVICE WITH OR IN ANNOUNCED PRODUCTION FOR THE UNITED STATES AND BRITISH AIR FORCES

January 1, 1944

| Original Designer  | Model                  |                       | Approved Name              |
|--------------------|------------------------|-----------------------|----------------------------|
|                    | U. S. Army             | U. S. Navy            |                            |
| <i>Bombers</i>     |                        |                       |                            |
| Boeing             | B-17                   |                       | Fortress                   |
| Douglas            | B-18                   |                       | Bolo                       |
| Douglas            | B-23                   |                       | Dragon                     |
| Consolidated       | B-24                   | PB4Y                  | Liberator                  |
| North American     | B-25                   | PBJ                   | Mitchell                   |
| Martin             | B-26                   | JM                    | Marauder                   |
| Boeing             | B-29                   |                       | Superfortress              |
| Vega               | B-34                   | PV                    | Ventura                    |
| <del>Douglas</del> | <del>A-20 (P-70)</del> | <del>BD</del>         | <del>Havoc (Boston)*</del> |
| Douglas            | A-24                   | SBD                   | Dauntless                  |
| Curtiss            | A-25                   | SB2C, SBW, and SBF    | Helldiver                  |
| Lockheed           | A-29                   | PBO                   | Hudson                     |
| Martin             | A-30                   |                       | Baltimore                  |
| Vultee             | A-31, A-35             |                       | Vengeance                  |
| Brewster           | A-34                   | SB2A                  | Bermuda                    |
| North American     | A-36 (P-51)            |                       | Mustang                    |
| Grumman            |                        | TBF, TBM              | Avenger                    |
| Consolidated       | OA-10                  | PBY, PB2B, and PBN    | Catalina                   |
| Consolidated       |                        | PB2Y                  | Coronado                   |
| Martin             |                        | PBM                   | Mariner                    |
| <i>Fighters</i>    |                        |                       |                            |
| Lockheed           | P-38                   |                       | Lightning                  |
| Bell               | P-39                   |                       | Airacobra                  |
| Curtiss            | P-40                   |                       | Warhawk (Kittyhawk)*       |
| Republic           | P-43                   |                       | Lancer                     |
| Republic           | P-47                   |                       | Thunderbolt                |
| North American     | P-51 (A-36)            |                       | Mustang                    |
| Northrop           | P-61                   |                       | Black Widow                |
| Douglas            | P-70 (A-20)            |                       | Havoc (Boston)*            |
| Vought-Sikorsky    |                        | F4U, FG, and F2G, F3A | Corsair                    |
| Grumman            |                        | F6F                   | Hellcat                    |
| Grumman            |                        | F4F, FM               | Wildcat                    |
| <i>Liaison</i>     |                        |                       |                            |
| Taylorcraft        | L-2 (O-57)             |                       | Grasshopper                |
| Aeronca            | L-3 (O-58)             |                       | Grasshopper                |
| Piper              | L-4 (O-59)             | NE                    | Grasshopper                |
| Vultee             | L-5 (O-62)             | OY                    | Sentinel                   |
| <i>Observation</i> |                        |                       |                            |
| Vultee             | O-49                   |                       | Vigilant                   |
| Curtiss            | O-52                   |                       | Owl                        |
| Lockheed           | O-56 (B-34)            |                       | Ventura                    |
| Taylorcraft        | O-57 (L-2)             |                       | Grasshopper                |
| Aeronca            | O-58 (L-3)             |                       | Grasshopper                |
| Piper              | O-59 (L-4)             |                       | Grasshopper                |
| Vultee             | O-62 (L-5)             |                       | Sentinel                   |
| Curtiss            |                        | SO3C                  | Seamew                     |
| Vought-Sikorsky    |                        | OS2U, OS2N            | Kingfisher                 |



*Finish the Fight with War Bonds*

## "Toughest Giants of the Skies"

In their first year, over the "hottest" spots in the world, the crews of Boeing Flying Fortresses of the 8th Air Force dropped more than 14,000 tons of bombs on submarine bases, transportation centers and war industries. They were credited with shooting down 1728 enemy planes, probably 671 others, and damaging another 870. And they were just getting well started! A great London daily termed the Fortresses: "Toughest giants of the skies."

A German military order, signed by Goering, has fallen into the hands of the U. S. Army Air Forces. It says, in part: "The mass of Fortresses are too dangerous for us to waste fighters on cripples. . . . Desperate maneuvers must be taken for us to break up the

main forces." The order continues that pilots breaking this rule would be sent to the Russian front as foot soldiers.

Most of the credit for the Fortresses' fine record goes to the superb crews who man them. And they are the first to say that much of it goes, too, to the Boeing men who designed these first American four-engined bombers . . . then manufactured them in such numbers that hundreds of Flying Fortresses today darken Axis skies in a single raid!

*The success of the Flying Fortress is the result of unusual qualities of research, design, engineering and manufacture. True today, it will be equally true in peacetime tomorrow . . . if it's "Built by Boeing" it's bound to be good.*

DESIGNERS OF THE FLYING FORTRESS • THE NEW B-29 SUPER BOMBER  
THE STRATOLINER • TRANSOCEAN CLIPPERS

**BOEING**



**AMERICAN AIRPLANES IN SERVICE WITH OR IN AN-  
NOUNCED PRODUCTION FOR THE UNITED STATES  
AND BRITISH AIR FORCES—Continued**

| <i>Original Designer</i> | <i>Model</i>                 |                   | <i>Approved Name</i> |
|--------------------------|------------------------------|-------------------|----------------------|
|                          | <i>U. S. Army</i>            | <i>U. S. Navy</i> |                      |
| <i>Trainers</i>          |                              |                   |                      |
| North American.....      | AT-6                         | SNJ               | Texan (Harvard)*     |
| Beech.....               | AT-7                         | SNB               | Navigator            |
| Beech.....               | AT-10                        | .....             | Wichita              |
| Beech.....               | AT-11                        | SNB               | Kansan               |
| Boeing.....              | AT-15                        | .....             | Crewmaker            |
| North American.....      | AT-16                        | .....             | Harvard              |
| Cessna.....              | AT-17 (UC-78)                | PBO               | Bobcat (Crane)*      |
| Lockheed.....            | AT-18 (A-29)                 | PBO               | Hudson               |
| Vultee.....              | AT-19                        | .....             | Reliant              |
| Fairchild.....           | AT-21                        | .....             | Gunner               |
| North American.....      | BT-9, BT-14                  | .....             | Yale                 |
| Fleetwing.....           | BT-12                        | .....             | Sophomore            |
| Boeing.....              | PT-13, PT-17<br>PT-18, PT-27 | N2S               | Caydet               |
| Fairchild.....           | PT-19, PT-23<br>PT-26        | .....             | Cornell              |
| Ryan.....                | PT-21, PT-22                 | NR                | Recruit              |
| Timm.....                | .....                        | N2T               | Tutor                |
| Curtiss.....             | .....                        | SNC               | Falcon               |
| <i>Transports</i>        |                              |                   |                      |
| Beech.....               | C-43                         | GB                | Traveller            |
| Beech.....               | C-45                         | JRB               | Expedito             |
| Curtiss.....             | C-46                         | R5C               | Commando             |
| Douglas.....             | C-47                         | R4D               | Skytrain (Dakota)*   |
| Douglas.....             | C-49, C-53                   | R4D               | Skytrooper (Dakota)* |
| Douglas.....             | C-54                         | R5D               | Skymaster            |
| Lockheed.....            | C-56, C-60                   | R5O               | Lodestar             |
| Fairchild.....           | UC-61                        | GK                | Forwarder (Argus)*   |
| Howard.....              | .....                        | GH                | Nightingale          |
| Lockheed.....            | C-63 (AT-18)                 | .....             | Hudson               |
| Curtiss.....             | C-76                         | .....             | Caravan              |
| Cessna.....              | UC-78 (AT-17)                | JRC               | Bobcat               |
| Consolidated.....        | C-87                         | RY                | Liberator            |
| Vought-Sikorsky.....     | .....                        | JR2S              | Excalibur            |
| Grumman.....             | OA-9                         | JRF               | Goose                |
| Grumman.....             | .....                        | J4F               | Widgeon              |

\* British name for this model.

## *Beechcrafts at work*

In the three specialized types of Beechcrafts shown in formation below, a large proportion of Air Forces bomber crews gain the skills that serve them so well in their flights over Axis targets. ★ Pilots learn the technique of handling heavy, fast, multi-engine bombers in the plywood AT-10 Beechcraft transitional trainer (leading formation). ★ Navigators master their complex art in the all-metal AT-7 (Navy SNB-2) Beechcraft navigation trainer (second in formation). ★ Bombardiers learn to make the most of those crucial split seconds over the target in the all-metal AT-11 (Navy SNB-1) Beechcraft bombing trainer (third in formation) which is also adaptable for instruction in flexible aerial gunnery. ★ Like the commercial Beechcrafts which were prototypes of the AT-7 and AT-11, these trainers combine near-tactical high cruising speeds with exceptionally low landing speeds, easy maneuverability, and great sturdiness. ★ Like the men they help to instruct, these Beechcrafts work hard and efficiently at their vital tasks with the world's finest Air Services



# Beech Aircraft

CORPORATION

BEECHCRAFTS ARE DOING THEIR PART



WICHITA, KANSAS, U S A

## LICENSED GROUND INSTRUCTORS IN THE UNITED STATES

January 1, 1944

Compiled by Statistical Section U. S. Civil Aeronautics Administration

| <i>State</i>                   | <i>Men</i> | <i>Women</i> | <i>Total</i> |
|--------------------------------|------------|--------------|--------------|
| Alabama . . . . .              | 119        | 8            | 127          |
| Arizona . . . . .              | 106        | 7            | 113          |
| Arkansas . . . . .             | 148        | 7            | 155          |
| California . . . . .           | 1,167      | 77           | 1,244        |
| Colorado . . . . .             | 191        | 19           | 210          |
| Connecticut . . . . .          | 109        | 6            | 115          |
| Delaware . . . . .             | 13         | 1            | 14           |
| District of Columbia . . . . . | 60         | 6            | 66           |
| Florida . . . . .              | 386        | 25           | 411          |
| Georgia . . . . .              | 241        | 4            | 245          |
| Idaho . . . . .                | 54         | 7            | 61           |
| Illinois . . . . .             | 517        | 31           | 548          |
| Indiana . . . . .              | 218        | 9            | 227          |
| Iowa . . . . .                 | 278        | 15           | 293          |
| Kansas . . . . .               | 305        | 15           | 320          |
| Kentucky . . . . .             | 65         | 4            | 69           |
| Louisiana . . . . .            | 140        | 5            | 145          |
| Maine . . . . .                | 85         | 6            | 91           |
| Maryland . . . . .             | 132        | 11           | 143          |
| Massachusetts . . . . .        | 380        | 19           | 399          |
| Michigan . . . . .             | 272        | 15           | 287          |
| Minnesota . . . . .            | 182        | 8            | 190          |
| Mississippi . . . . .          | 71         | 6            | 77           |
| Missouri . . . . .             | 533        | 22           | 555          |
| Montana . . . . .              | 123        | 6            | 129          |
| Nebraska . . . . .             | 162        | 7            | 169          |
| Nevada . . . . .               | 42         | 7            | 49           |
| New Hampshire . . . . .        | 59         | 5            | 64           |
| New Jersey . . . . .           | 433        | 20           | 453          |
| New Mexico . . . . .           | 81         | 6            | 87           |
| New York . . . . .             | 1,292      | 61           | 1,353        |
| North Carolina . . . . .       | 97         | 9            | 106          |
| North Dakota . . . . .         | 54         | 3            | 57           |
| Ohio . . . . .                 | 462        | 28           | 490          |
| Oklahoma . . . . .             | 460        | 37           | 497          |
| Oregon . . . . .               | 79         | 2            | 81           |
| Pennsylvania . . . . .         | 745        | 36           | 781          |
| Rhode Island . . . . .         | 66         | 4            | 70           |
| South Carolina . . . . .       | 102        | 7            | 109          |
| South Dakota . . . . .         | 77         | 6            | 83           |
| Tennessee . . . . .            | 181        | 12           | 193          |
| Texas . . . . .                | 848        | 82           | 930          |
| Utah . . . . .                 | 103        | 5            | 108          |
| Vermont . . . . .              | 60         | 2            | 62           |
| Virginia . . . . .             | 134        | 7            | 141          |
| Washington . . . . .           | 247        | 9            | 256          |
| West Virginia . . . . .        | 108        | 8            | 116          |
| Wisconsin . . . . .            | 148        | 18           | 166          |
| Wyoming . . . . .              | 37         | 2            | 39           |
| Alaska . . . . .               | 6          | 0            | 6            |
| Canada . . . . .               | 14         | 0            | 14           |
| Canal Zone . . . . .           | 2          | 0            | 2            |
| Hawaiian Islands . . . . .     | 12         | 0            | 12           |
| Mexico . . . . .               | 0          | 0            | 0            |
| Foreign, Misc. . . . .         | 11         | 0            | 11           |
| Total . . . . .                | 12,017     | 722          | 12,739       |

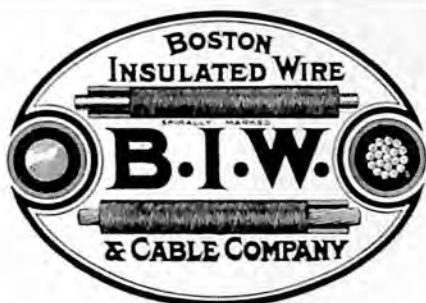

**ELECTRIC CABLES for AIRCRAFT**  
**LIGHTING AND POWER CABLES**  
**SHIELDING IGNITION CABLE**  
**BONDING WIRE ANTENNA WIRE**  
**INSTRUMENT WIRES AND CABLES**

*Manufactured in accordance with latest Army and Navy Specifications*

Special multiple conductor cable made to order — designed for particular applications on instruments and apparatus

**BOSTON INSULATED WIRE AND CABLE COMPANY**  
**BOSTON, MASSACHUSETTS**

**JACOEL**  
 Cable **SPLICER**



Cables from 1/16 to 1" diameter for Thimbles, Bushings, Spacer, now quicker and better handled by Jacoel Cable Splicing Equipment. U. S. Govt., Aircraft Factories, Schools, Repair Stations, all are enthusiastic users.

**JACOEL CABLE SPLICING EQUIP. CO., 1514 Main St., Buffalo 9, N. Y.**

**Precision Machining**  
**of Aircraft Parts**

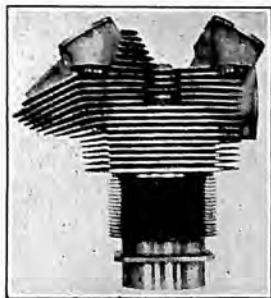

The fact that over a long period of years we have been doing precision machine work for leading makers of automotive and aircraft engine parts testifies, we believe, to our ability to serve you well, should you have a machining problem difficult to solve.

Write Us Concerning Your Requirements!

**THE GOVRO-NELSON COMPANY**

**1931 Antoinette Detroit 8, Mich.**

## FLYING FACTS AND FIGURES

## AIRPORTS AND LANDING FIELDS

January 1, 1944

Compiled by Information and Statistics Service  
U. S. Civil Aeronautics Administration

| <i>State</i>              | <i>Municipal</i> | <i>Commercial</i> | <i>Miscellaneous Government</i> | <i>Private</i> | <i>Total</i> | <i>Intermediate</i> | <i>Lighted</i> |
|---------------------------|------------------|-------------------|---------------------------------|----------------|--------------|---------------------|----------------|
| Alabama.....              | 20               | 8                 | 0                               | 0              | 28           | 5                   | 8              |
| Arizona.....              | 15               | 13                | 4                               | 0              | 32           | 9                   | 14             |
| Arkansas.....             | 11               | 13                | 0                               | 0              | 24           | 3                   | 7              |
| California.....           | 47               | 42                | 12                              | 2              | 103          | 13                  | 28             |
| Colorado.....             | 20               | 9                 | 0                               | 1              | 30           | 3                   | 7              |
| Connecticut.....          | 4                | 9                 | 0                               | 0              | 13           | 1                   | 3              |
| Delaware.....             | 1                | 5                 | 0                               | 0              | 6            | 0                   | 1              |
| District of Columbia..... | 1                | 0                 | 0                               | 0              | 1            | 0                   | 1              |
| Florida.....              | 37               | 17                | 1                               | 0              | 55           | 4                   | 14             |
| Georgia.....              | 16               | 6                 | 0                               | 0              | 22           | 9                   | 14             |
| Idaho.....                | 25               | 8                 | 7                               | 0              | 40           | 5                   | 10             |
| Illinois.....             | 17               | 49                | 0                               | 0              | 66           | 6                   | 15             |
| Indiana.....              | 15               | 24                | 0                               | 0              | 39           | 5                   | 12             |
| Iowa.....                 | 17               | 19                | 0                               | 2              | 38           | 4                   | 10             |
| Kansas.....               | 28               | 15                | 1                               | 1              | 45           | 5                   | 12             |
| Kentucky.....             | 7                | 7                 | 0                               | 0              | 14           | 3                   | 5              |
| Louisiana.....            | 11               | 14                | 0                               | 0              | 25           | 4                   | 7              |
| Maine.....                | 17               | 4                 | 0                               | 0              | 21           | 0                   | 8              |
| Maryland.....             | 3                | 9                 | 0                               | 1              | 13           | 0                   | 2              |
| Massachusetts.....        | 10               | 20                | 0                               | 1              | 37           | 1                   | 5              |
| Michigan.....             | 60               | 24                | 3                               | 4              | 91           | 2                   | 16             |
| Minnesota.....            | 18               | 14                | 0                               | 1              | 33           | 2                   | 6              |
| Mississippi.....          | 10               | 8                 | 0                               | 0              | 24           | 7                   | 8              |
| Missouri.....             | 8                | 10                | 0                               | 0              | 27           | 10                  | 14             |
| Montana.....              | 40               | 1                 | 12                              | 1              | 54           | 14                  | 22             |
| Nebraska.....             | 24               | 5                 | 0                               | 0              | 29           | 5                   | 11             |
| Nevada.....               | 10               | 7                 | 1                               | 0              | 24           | 10                  | 15             |
| New Hampshire.....        | 10               | 5                 | 0                               | 0              | 15           | 0                   | 4              |
| New Jersey.....           | 7                | 21                | 0                               | 1              | 29           | 0                   | 3              |
| New Mexico.....           | 21               | 8                 | 5                               | 5              | 39           | 10                  | 10             |
| New York.....             | 36               | 64                | 0                               | 1              | 101          | 3                   | 22             |
| North Carolina.....       | 18               | 10                | 0                               | 0              | 34           | 1                   | 5              |
| North Dakota.....         | 12               | 0                 | 0                               | 0              | 12           | 8                   | 10             |
| Ohio.....                 | 29               | 51                | 0                               | 2              | 82           | 8                   | 18             |
| Oklahoma.....             | 28               | 25                | 0                               | 3              | 56           | 5                   | 12             |
| Oregon.....               | 17               | 3                 | 0                               | 0              | 20           | 4                   | 11             |
| Pennsylvania.....         | 35               | 74                | 0                               | 2              | 111          | 3                   | 16             |
| Rhode Island.....         | 0                | 1                 | 0                               | 0              | 1            | 0                   | 0              |
| South Carolina.....       | 10               | 6                 | 0                               | 2              | 18           | 2                   | 4              |
| South Dakota.....         | 11               | 7                 | 0                               | 0              | 18           | 2                   | 4              |
| Tennessee.....            | 11               | 6                 | 0                               | 0              | 17           | 8                   | 13             |
| Texas.....                | 60               | 73                | 0                               | 4              | 137          | 25                  | 40             |
| Utah.....                 | 16               | 1                 | 0                               | 0              | 17           | 8                   | 17             |
| Vermont.....              | 9                | 2                 | 0                               | 0              | 11           | 0                   | 3              |
| Virginia.....             | 13               | 21                | 0                               | 0              | 34           | 5                   | 11             |
| Washington.....           | 24               | 9                 | 3                               | 0              | 36           | 4                   | 10             |
| West Virginia.....        | 8                | 10                | 0                               | 0              | 18           | 2                   | 3              |
| Wisconsin.....            | 15               | 21                | 1                               | 0              | 37           | 3                   | 7              |
| Wyoming.....              | 20               | 2                 | 0                               | 1              | 23           | 9                   | 15             |
| Total.....                | 914              | 801               | 50                              | 35             | 1,802*       | 240**               | 525            |

\* Does not include 320 inoperative airports.

\*\* Includes 3 fields which were constructed but not commissioned on Jan. 1, 1944.

# BARRETT AIRCRAFT BRAKE EQUIPMENT

**THE BARRETT AIRCRAFT  
BRAKE DOKTER**—grinds the  
brake lining to exact drum diameter  
—on the production line or in the  
service shop, on the plane or  
on the bench.

*Used by Army, Navy and  
many of the large airports  
and plane manufacturers.*



**THE BARRETT AIRCRAFT  
BRAKE DRUM LATHE**  
Handles all drums from the  
largest to the smallest. Made  
especially for aviation work.



**Model B-117 illustrated.  
Several Models Available.**



**Write for Complete Literature  
and Demonstration Today!**



**BARRETT  
RELINERS**

*Equipped for riv-  
eting, de-rivet-  
ing and counter-  
sinking aircraft  
brake lining.*

**BARRETT EQUIPMENT CO.**

*The World's Finest Brake Equipment*

CASS AVENUE AT 21st STREET ★ ST. LOUIS 6, MISSOURI

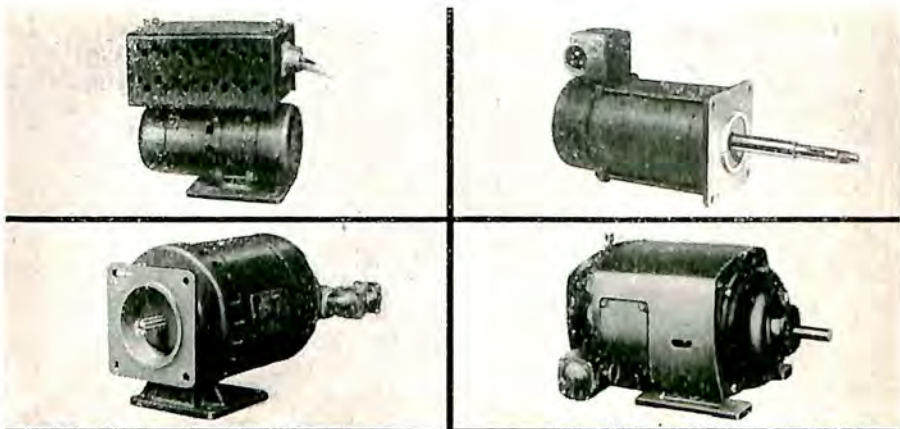

## Motors and Power Generators

Leland designs and builds a wide range of motors for aeronautical applications, in sizes 1/6 to 3 HP singlephase and 1/6 to 5 HP polyphase. The four units here shown are typical and should suggest Leland as a logical source for many of your requirements. As motor design problems arise consult Leland.

*Is the name Leland in your file of motor sources? Make sure.*

*The Leland Electric Company, Dayton, 1, Ohio*

1. Aircraft high frequency motor alternator set for operating radio equipment.
2. Aircraft type DC motor to operate landing gear.
3. General purpose Aircraft type motor.
4. Continuous duty explosion proof gasoline pump motor.

# LELAND

## W E L L M A N NON-FERROUS C A S T I N G S

ALUMINUM  
AMPCO BRONZE  
MAGNESIUM  
BRONZE  
BRASS

### FACILITIES

1. Two modern plants, well-equipped pattern shop (wood or metal); new heat-treating equipment.
2. Precision workmanship; rigid production and inspection standards.
3. Experienced personnel—33 years in brass and aluminum, 13 years in magnesium.
4. Modern laboratory, including X-ray equipment, for quality checking.

THE WELLMAN BRONZE  
& ALUMINUM CO.

General Offices  
2531 E. 93rd Street, Cleveland, Ohio

## GENERAL CONTROLS AIRCRAFT TYPE ELECTRIC VALVES

Provide The Solution To  
Pilot Supervisory, Pressure  
and Temperature Problems

Operate in any position; unaffected by vibration or acceleration; save weight, space and tubing. Type AV-1 (shown) designed for engine priming, oil dilution and fuel control to heaters. Complete line includes aircraft hydraulic valves and high pressure selector valves for all services and pressures. Write for details. Manufacturers of engine temperature controls.



## GENERAL CONTROLS

Pioneers and Leaders in the Development  
and Manufacture of Magnetic Valves

801 ALLEN AVENUE, GLENDALE 1, CALIF.

BOSTON • NEW YORK • PHILADELPHIA  
CLEVELAND • DETROIT • CHICAGO  
DALLAS • DENVER • SAN FRANCISCO  
ATLANTA



# SUPERIOR TUBE COMPANY

Norristown, Pennsylvania.

METAL TUBING MANUFACTURERS

## SEAMLESS TUBING



Steel  
 Alloy Steels  
 Stainless Steels  
 Composite (Steel  
 and Copper)  
 Nickel  
 "Monel"  
 "Inconel"  
 Copper  
 Beryllium Copper  
 Aluminum

## WELDRAWN TUBING (welded, then drawn)

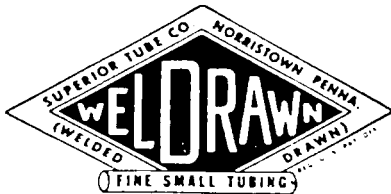

Stainless Steels  
 Low Carbon Steel  
 Chrome-Moly Steel  
 "Monel"  
 "Inconel"

## FABRICATED PRODUCTS

Alloy Steel Valve Push Rods for Aircraft,  
 and Tank Engines  
 Antennas in WELDRAWN "Monel" for  
 Aircraft and Marine Installations;  
 Also, for Automotive Purposes

## INDEX OF ADVERTISERS

- Academy of Aeronautics, 685  
 Acme Pattern & Tool Co., Inc., 505  
 Adel Precision Products Corp., 401  
 Aero Digest, magazine, 398-399  
 Aero Supply Mfg. Co., Inc., 695  
 Aeronca Aircraft Corp., 692  
 Aeroproducts Div., General Motors Corp., 421  
 Air Communications, Inc., 509  
 Aircraft Hardware Mfg. Co., 691  
 Aircraft & Marine Specialty Co., 641  
 Aircraft Mechanics, Inc., 692  
 Aircraft Radio Corp., 471  
 Aircraft Screw Products Co., Inc., 633  
 Aircraft Welders, Inc., 412  
 Allison Div., General Motors Corp., 408  
 Alloys Foundry Inc., 475  
 American Bosch Corp., 513  
 American Chemical Paint Co., 433  
 American Hard Rubber Co., 415  
 American Screw Co., 517  
 American Tube Bending Co., Inc., 448  
 Anderson Bros. Mfg. Co., 655  
 Apex Machine & Tool Co., 516  
 Appel, S., & Co., 433  
 Aro Equipment Corp., 519  
 Atlantic India Rubber Works, Inc., 695  
 Atlantic Rayon Corp., Industrial Fabrics Div., 448  
 Automatic Electric Co., 521  
 Aviquipo, Inc., 449  
  
 B G Corp., 487  
 B. H. Aircraft Co., Inc., 523  
 Barr Shipping Co., 685  
 Barrett Equipment Co., 707  
 Beech Aircraft Corp., 703  
 Bell Aircraft Corp., 665  
 Bell Co., Inc., 685  
 Bellanca Aircraft Corp., 645  
 Belmont Radio Corp., 483  
 Bendix Aviation Corp., 525  
 Bendix Products Div., Bendix Aviation Corp., 531, 535  
 Benwood Linze Co., 434  
 Bluefries-New York, Inc., 640  
 Boeing Airplane Co., 701  
 Bolton Manufacturing Corp., 503  
 Boots Aircraft Nut Corp., 451  
 Boston Insulated Wire & Cable Co., 705  
 Breeze Corporations, Inc., 425  
  
 Champion Spark Plug Co., 537  
 Chandler-Evans Corp., 683  
 Chicago Aerial Survey Co., 671  
 Chicago Wheel & Mfg. Co., 539  
 Clare, C. P., & Co., 443  
 Clarke Aero-Hydraulics Co., 691  
 Clark Tractor, Div. of Clark Equipment Co., 459  
 Cleveland Pneumatic Tool Co., 433  
 Clifford Manufacturing Co., 445  
 Climax Molybdenum Co., 557  
 Consolidated Radio Products Co., 541  
 Consolidated Vultee Aircraft Corp., 403  
 Continental Motors Corp., 609  
 Cook Electric Co., 547  
 Couse Laboratories, 641  
 Cox & Stevens Aircraft Corp., 543  
 Coxhead, Ralph C., Corp., 559  
 Crescent Insulated Wire & Cable Co., 673  
 Curtiss Wright Corp., Airplane Div., 413  
 Curtiss Wright Corp., Propeller Div., 545  
 Curtiss Wright Technical Institute, 697  
  
 Davison Chemical Corp., 439  
 Denison Engineering Co., 695  
 Detroit Macoid Corp., 551  
 Douglas Aircraft Co., 405  
 Dow Chemical Co., 583  
 Duramold Div., Fairchild Engine & Airplane Corp., 667  
 Dzus Fastener Co., Inc., 549  
  
 Eagle Parachute Corp., 657  
 Eastern Air Devices, Inc., 692  
 Eastman Kodak Co., 663  
 Eclipse-Pioneer Div., Bendix Aviation Corp., 527, 529  
 Edo Aircraft Corp., 455  
 Electric Auto-Lite Co., 427  
 Engineering & Research Corp., 553  
 Exact Weight Scale Co., 423  
  
 Fairchild Div., Fairchild Engine & Airplane Corp., 667  
 Fairchild Engine & Airplane Corp., 667  
 Federal Products Corp., 677  
 Firestone Aircraft Co., 489  
 Flex-O-Tube Co., 519

- Foote Bros. Gear & Machine Corp., 437  
 Formica Insulation Co., 555  
 G & O Manufacturing Co., 420  
 General Controls Co., 708  
 General Electric Co., 560-561  
 Globe Steel Tubes Co., 563  
 Goodrich, B. F., Co., 507  
 Govro-Nelson Co., 705  
 Graham Rotary File & Tool Co., 521  
 Grimes Manufacturing Co., 465  
 Grumman Aircraft Engineering Corp., 651  
 Guiberson Diesel Engine Co., 447  
 Hall Manufacturing Co., 569  
 Hallicrafters Co., 565  
 Hamilton Standard Propellers Div. of United Aircraft Corp., 419  
 Harris-Seybold-Potter Co., 467  
 Hartzell Propeller Co., 471  
 Harvey-Wells Communications, Inc., 653  
 Haskelite Manufacturing Corp., 567  
 Hayes Manufacturing Corp., 519  
 Hewitt Rubber Corp., 677  
 Houghton, E. F., & Co., 571  
 Hub Industries, Inc., 516  
 Hyland Machine Co., 575  
 Industrial Sound Control, 653  
 International Flare-Signal Div. of Kilgore Manufacturing Co., 577  
 Interstate Aircraft & Engineering Corp., 573  
 J. V. W. Corp., 689  
 Jacobs Aircraft Engine Co., 417  
 Jacoel Cable Splicing Equipment Co., 705  
 Jones, Casey, School of Aeronautics, 685  
 Jowain, Inc., 516  
 Kellogg Switchboard & Supply Co., 441  
 Kennametal Inc., 579  
 Kilgen Aircraft, 500  
 Koehler Aircraft Products Co., 655  
 Kollman Instrument Co., 687  
 Kropp Forge Aviation Co., 643  
 Lanciar Publishers, Inc., 396  
 Lasalco, Inc., 434  
 Leach Relay Co., Inc., 504  
 Lea Manufacturing Co., 435  
 Leece-Neville Co., 581  
 Leland Electric Co., 708  
 Liberty Aircraft Products Corp., 429  
 Liberty Motors & Engineering Corp., 493  
 Link Aviation Devices, Inc., 689  
 Link-Belt Co., 583, 663  
 Liquidometer Corp., 639  
 Littelfuse Inc., 583  
 Lockheed Aircraft Corp., 409  
 Lord Manufacturing Co., 497  
 Lyon-Raymond Corp., 585  
 McArthur, Warren, Corp., 404  
 McDonnell Aircraft Corp., 407  
 Macwhyte Co., 511  
 Manufacturers Screw Products, 678  
 Marquette Metal Products Co., 491, 499  
 Martin, Glenn L., Co., 669  
 Mercury Aircraft, Inc., 587  
 Metal & Tool Reconditioning Service, 599  
 Micro Switch Corp., 589  
 Monogram Manufacturing Co., 591  
 Moore-Eastwood & Co., 603  
 National Screw & Mfg. Co., 593  
 Nelson, Herman, Corp., 595  
 Norma-Hoffman Bearings Corp., 647  
 North American Aviation, Inc., 411  
 Northrop Aircraft Inc., 659  
 Numberall Stamp & Tool Co., Inc., 599  
 Onsrud Machine Works, Inc., 469  
 Pacific Aviation, Inc., 597  
 Palnut Co., 647  
 Parks Air College, Inc., 681  
 Permoflux Corp., 599  
 Pioneer Parachute Co., Inc., 504  
 Porter-Cable Machine Co., 603  
 Ranger Aircraft Engines Div., Fairchild Engine & Airplane Corp., 667  
 Remington Rand, Inc., 608  
 Republic Aviation Corp., 649  
 Revista Aerea, magazine, 398-399  
 Roebing's, John A., Sons Co., 611  
 Rohr Aircraft Corp., 418  
 Roosevelt Aviation School, 699  
 Roxalin Flexible Finishes, Inc., 453  
 Ryan Aeronautical Co., 661  
 S K F Industries, Inc., 613  
 Schrader's, A., Son, Div. of Scovill Manufacturing Co., Inc., 495  
 Scintilla Magneto Div., Bendix Aviation Corp., 533  
 Sensenich Bros., 481  
 Seybold Div., Harris-Seybold-Potter Co., 467  
 Sheffield Corp., 615  
 Sikorsky Aircraft Div. of United Aircraft Corp., 419

- Simmonds Aerocessories, Inc., 420  
 Sinclair Refining Co., 657  
 Socony-Vacuum Oil Co., Inc., 681  
 Solar Aircraft Co., 619  
 Southern California Airparts Div. of  
   Jarvis Mfg. Co., 663  
 Spencer & Morris, 675  
 Sperry Gyroscope Co., Inc., 461  
 Spool Cotton Co., 621  
 Spriesch Tool & Mfg. Co., Inc., 647  
 Standard Aircraft Products, Inc., 463  
 Standard Oil Company of California,  
   693  
 Stewart Technical School, 657  
 Summerill Tubing Co., 479  
 Superior Tube Co., 709  
 Surface Combustion, 623  
 Switlik Parachute Co., 471
- Taylor-Winfield Corp., 625  
 Technical Ply-Woods, 677  
 Texas Co., 683  
 Thompson Grinder Co., 678  
 Thompson Products, Inc., 431  
 Thurston, W. Harris, Inc., 675  
 Timken Roller Bearing Co., 627  
 Tinnerman Products, Inc., 601  
 Titeflex Inc., 485  
 Tomkins-Johnson Co., 605  
 Tube Turns, Inc., 607
- Union Aircraft Products Corp., 617  
 United Aircraft Corp., 419  
 United Aircraft Products, Inc., 501  
 United-Carr Fastener Corp., 629  
 United States Gauge Co., 691  
 United States Plywood Corp., 631  
 Utica Drop Forge & Tool Corp., 655
- Victor Metal Products Corp., 633  
 Vinco Corp., 457  
 Vought, Chance, Aircraft Div. of  
   United Aircraft Corp., 419
- Waco Aircraft Co., 415  
 Waldes Koh-I-Noor, Inc., 473  
 Weatherhead Co., 635  
 Weber Showcase & Fixture Co. Inc.,  
   477  
 Weems System of Navigation, 681  
 Wellman Bronze & Aluminum Co.,  
   708  
 Western Electric Co., 637  
 White, S. S., Dental Mfg. Co., 521  
 White-Rodgers Electric Co., 515  
 Wickes Bros., 671  
 Wiggins, E. W., Airways, Inc., 500  
 Wilson, H. A., Co., 675  
 Wittek Manufacturing Co., 639  
 Wright Aeronautical Corp., 422  
 Wyman-Gordon Co., 639

# INDEX

## INDEX

### A

- AVG, *see* American Volunteer Group.  
143
- Abbott, C. G., 652
- Abrasives, 424
- Academy of Aeronautics, 183
- Accessories manufacturers, 316-395:  
alphabetical directory, 502-642; clas-  
sified directory, 424-500
- Acme Pattern & Tool Co., 316-317
- Adel Precision Products Corp., 317
- Adhesives, 456
- Aerial attacks, 19-20, 30-31
- Aerial campaigns, 9-28, 52-60, 61-67,  
68-69, 71-90, 91
- Aero Digest, 301, 670
- Aerodynamics, 206-209
- Aeronautical Board, 203-204, 231
- Aeronautical Chamber of Commerce of  
America, 231; roster, 642; work of,  
217-220
- Aeronautical organizations, 217-238
- Aeronautical Periodicals, 670
- Aeronautical Radio, Inc., 353
- Aeronautical Review, 670
- Aeronautical University, 190
- Aeronca Aircraft Corp., 241
- Aeroproducts Div. of General Motors  
Corp., 317
- Afrika Korps, 11
- Air battles, *see* Battles
- Air Communications, Inc., 318-319
- Air compressors, 424
- Air conditioning equipment, 406
- Air Corps Enlisted Reserve, 128
- Air Facts, magazine, 670
- Air Force, *see* Army Air Forces and  
Navy air forces
- Air Law Review, magazine, 670
- Air Line Mechanic, magazine, 670
- Air Line Pilot, magazine, 670
- Air lines, *see* Air transport
- Air News, magazine, 670
- Air Power, 9-28
- Air raids, 52-90
- Air Tech, magazine, 670
- Air Trails, magazine, 670
- Air transport, 133-170; cargo, 137-138,  
139, 145-146; domestic routes, 161-  
170; international routes, 153-161;  
military, 40-41; modification centers,  
144-145; operations, 137, 199-200,  
682; revenue, 137; routes, 199-200,  
684-690; safety, 136, 142, 200, 690;  
status of, 680; summary, 680; train-  
ing, 139-140, 142-143
- Air Transport, magazine, 670
- Air Transport Association of America,  
133, 140, 163; roster, 642
- Air Transport Command, *see* Army  
Air Forces, 136
- Air war, 9-28
- Aircooled Motors Corp., 306
- Aircraft Accessories Corp., 319
- Aircraft carriers, *see* Carriers
- Aircraft Engine Research Laboratory,  
207
- Aircraft Hardware Manufacturing Co.,  
Inc., 319
- Aircraft manufacturers, 241-306
- Aircraft manufacturing industry, 241-  
395; absenteeism, 230, 242, 270; con-  
servation of material, 270, 293; em-  
ployees earnings, 698; employment of  
women, 250, 205, 316, 371; expansion,  
43-44, 47; increased manufacturing  
efficiency, 195-196, 243, 249-250, 292,  
290-300, 302-303, 312, 333, 339, 351,  
361-362, 369-370, 393; industrial re-  
lations, 232-233, 251-252, 264-265,  
308; industrial safety, 230; man-  
power, 194, 222, 224-226, 228-229, 232,  
248, 250, 270, 281, 292, 295, 331; ma-  
terials shortages, 222, 228; personnel  
increase, 47; postwar planning, 287;  
production, 42-43, 45-46, 193, 194-195,

- 224, 230-231, 242, 246, 249, 256-257, 260-262, 265, 270, 283, 288-289, 297, 302-303, 308, 311, 312, 314, 317, 321, 331, 339, 351, 372, 376; production methods, 228, 231-232, 262-264; safety, 283; subcontracting, 243, 249, 272, 278, 280, 283, 306, 319, 349, 357, 375, 395; training, 243, 259-260, 265, 283, 286-287, 292, 295, 309; upgrading, 243
- Aircraft Mechanics, Inc., 319
- Aircraft Owners and Pilots Association, 220; roster, 654
- Aircraft Production Board, 193-196
- Aircraft Radio Corp., 319
- Aircraft Resources Control Office, 193, 194, 195-196
- Aircraft Screw Products Co., 319
- Aircraft War Production Councils, 220-233
- Aircraft War Production Council, East Coast, committees, 664-668; members, 230; work of, 230-233
- Aircraft War Production Council, West Coast, committees, 658-662; members, 222-223; work of, 222-230
- Aircraft Welders, Inc., 319-320
- Aircraft Year Book, 670
- Airlanes, magazine, 670
- Airline War Training Institute, 142
- Airplanes, aerodynamic improvements, 32-35; deliveries, 195; designs, 242-305; in war service, 29, 700-702; manufacturers, 241-306, 400-410; number produced, 195; performance, 250, 254, 260, 265-269, 276-277, 279, 284-286, 287, 288-292, 294; technical superiority, 29, 30, 31-32, 98-99, 248, 250, 293
- Airport equipment, 424-426
- Airport Reference, magazine, 670
- Airports, 196, 197; number of, 706
- Airways traffic control, 196-197, 214
- Alexander, H., 68, 69
- All-American Aviation, 134, 135, 142
- Allied Aviation Corp., 320
- Allison Div., General Motors Corp., 306-309
- Alloys Foundry, Inc., 320
- Aluminum Co. of America, 320-321
- Ambrose, F., 190
- American Airlines, 134, 135, 140, 142, 146, 161-164, 183
- American Aviation, magazine, 670
- American Aviation Daily, 670
- American Aviation Directory, 670
- American Chemical Paint Co., 321
- American Export Airlines, 134, 135, 138, 146
- American Hard Rubber Co., 321
- American Meteorological Society, 234
- American Propeller Corp., 230, 321
- American Screw Co., 322
- American Tube Bending Co., 322
- American Volunteer Group, 143
- Ames Aeronautical Laboratory, 207, 235
- Ammunition boxes and counters, 426
- Anderson, F., 59
- Andrews, P., 648
- Anti-submarine campaign, 93-97
- Apex Machine & Tool Co., 322
- Armament, aircraft, 325, 424
- Army Air Forces, 49-90: Air Corps Ferrying Command, 147, 148; Air Service Command, 72, 150-151; Air Transport Command, 133, 136, 139, 143, 145, 146, 147, 148, 153, 154, 155, 161-162, 163, 164, 165, 166, 167-168; Aviation Cadet Branch, 128; roster, 648; strength of, 49; Tactical Center, 173-174; Technical Training Command, 183; training, 171-176; Training Command, 49, 164; Troop Carrier Command, 49, 62
- Arnold, H. H., 15-17, 17-19, 22-23, 24-27, 43-47, 49, 72, 76-80, 82, 110, 125, 147-153, 171-176, 254, 648, 652
- Aro Equipment Corp., 322
- Atlantic India Rubber Works, 322
- Atlantic Rayon Corp., Industrial Fabrics Div., 322
- Autogiros, 278
- Automatic Electric Co., 322-323
- Auxiliary motors, 340, 360-361, 381, 440
- Auxiliary power plants, 360-361, 426
- Aviation, magazine, 670
- Aviation Corp., 230
- Aviation Division, Department of State, 196
- Aviation Equipment, magazine, 670



Aviation Institute of Technology, 190  
 Aviation News, magazine, 670  
 Aviation Writers Association, 648  
 Avion Inc., 280

## B

B G Corp., 323  
 B. H. Aircraft Co., 323  
 Baffles, 438  
 Bailey, H., 648  
 Bane, Thurman H., Award, 235  
 Barrett Equipment Co., 323  
 Baruch, B. M., 222  
 Basic materials and fabrications, 336,  
 356-357, 374, 426  
 Batteries, 426  
 Battles, 21, 22-23, 91, 92  
 Beall, W. E., 646  
 Bearings, 371, 376-377, 426-428  
 Beck, T. H., 127  
 Beebe, E., 72  
 Beech Aircraft Corp., 242-246  
 Bell, L. D., 642, 664  
 Bell Aircraft Corp., 230, 246-248  
 Bell Co., Inc., 323  
 Bellanca Aircraft Corp., 249, 271  
 Bellinger, P. N. L., 650  
 Belmont Radio Corp., 323-324  
 Bendix Aviation Corp., Bendix Prod-  
 ucts Div., Landing Gear Dept., 324;  
 Stromberg Dept., 324  
 Bendix Aviation Corp., Eclipse-Pioneer  
 Div., 339-341; Pacific Div., 324;  
 Scintilla Magneto Div., 377  
 Benwood Linze Co., 324  
 Bergen, W. B., 235  
 Bevans, J. H., 648  
 Bismarck Sea, battle of, 22-23  
 Bissell, C., 71, 72, 75  
 Blee, H. H., 124  
 Boeing Aircraft Co., 217, 222, 249-255  
 Bolton Manufacturing Corp., 324  
 Bolts, 450  
 Bomb racks, 428  
 Boots Aircraft Nut Corp., 324  
 Boston Insulated Wire & Cable Co.,  
 324-325  
 Bourne, T. B., 656  
 Box score, 20, 117, 248, 250, 260, 265-  
 266, 304

Brackets, 438  
 Bradley, S. S., 236, 644  
 Brakes and parts, 428  
 Brand, H., Jr., 217, 642  
 Braniff Airways, 134, 135, 140, 142, 146,  
 164  
 Branshaw, C. E., 648  
 Brashear, H. R., 642  
 Brazilian Aeronautical Commission,  
 271  
 Breech, E. R., 642  
 Breeze Corporations, 325-326  
 Brereton, L. H., 61, 62, 69, 71, 77  
 Brewster Aeronautical Corp., 255  
 Briggs, L. J., 652  
 British Air Ministry, 246  
 British Commonwealth Air Training  
 Program, 52  
 Brukner, C. J., 642, 644  
 Bryan, O., 167  
 Buhl Stamping Co., 326  
 Burden, W. A. M., 652  
 Bureau of Aeronautics, U. S. Navy,  
 193, 384; *see also* Navy air forces  
 Burgess, R. S., 650  
 Burma Campaign, 71-80  
 Burton, A. T., 644  
 Bush, V., 652  
 Bushings, 428-430  
 Butler, W. O., 88  
 Byrnes, J., 222

## C

Cables, control, 367, 375; electrical, 329  
 Cal-Aero Flight Academy, 183  
 California Flyers, Inc., 326  
 Cameras and supplies, 430  
 Camloc Fastener Corp., 326  
 Cams, 444  
 Camshafts, 444  
 Cannon, J. K., 62, 69  
 Carburetors, 326, 430  
 Carriers, 92, 94-95  
 Case, N. S., 652  
 Castings, 393, 430  
 Central Pacific Campaign, 104-107, 111-  
 112, 112-115  
 Cessna Aircraft Co., 255  
 Chamberlin, E. H., 652  
 Champion Spark Plug Co., 326

- Chandler-Evans Corp., 326  
 Chanute, Octave, Award, 234-235  
 Chatfield, C. H., 644  
 Chennault, C., 71, 73, 76, 158  
 Chicago Aerial Survey Co., 326  
 Chicago & Southern Airlines, 134, 135, 140, 142, 146  
 Chicago Wheel & Manufacturing Co., 327  
 China, 23  
 China campaign, 71-80  
 China National Aviation Corp., 158  
 Chinese Air Force, 75  
 Chinn, H., 158  
 Chinn, M., 158  
 Civil Aeronautics Administration, 171, 174, 188, 214, 216; pilot training, 179-182; roster, 656; *see also* Training: War Training Service, 125, 177, 197, 198, 301-302, 306; work of, 196-199  
 Civil Aeronautics Board, 133, 134; work of, 199-200  
 Civil Air Patrol, 123-132, 199, 200, 204, 256, 298; Cadet training, 127-130  
 Civilian Pilot Training Program, 174, 180, 256, 301  
 Clamps, 368, 430-432  
 Clark, M., 68  
 Clark Trutractor Div. of Clark Equipment Co., 327-328  
 Cleaners, 432  
 Cleaning compounds, 432  
 Cleveland Pneumatic Tool Co., 328  
 Clifford Manufacturing Co., 328  
 Clothing and equipment, 432  
 Cloths, 446  
 Coast and Geodetic Survey, 174  
 Coast Guard aviation, 119-122, 202  
 Coffey, H. K., 644  
 Cohu, L. T., 642, 658  
 Collector Rings, 432  
 Collier Trophy, 138  
 Colonial Airlines, 134, 135, 142  
 Colvin, C. H., 646  
 Commonwealth Aircraft, Inc., 256  
 Compania Mexicana de Aviacion, 160  
 Compasses, radio, 482  
 Congressional Committees, 672-676  
 Coningham, A., 62, 69  
 Consairway, 134  
 Consolidated Radio Products Co., 328  
 Consolidated Vultee Aircraft Corp., 134, 222, 256-260, 280  
 Construction, 432  
 Continental Airlines, 134, 135, 142, 146, 164-165  
 Continental Motors Corp., 309  
 Controls, 317, 379, 394, 432-436, 460  
 Controls, hydraulic, 584  
 Cook Electric Co., 328-329  
 Coral Sea, battle of, 22  
 Couse Laboratories, 329  
 Covers, 436  
 Cowlings, 436-438  
 Cox and Stevens Aircraft Corp., 329  
 Coxhead, Ralph C., Corp., 329  
 Craig, H. A., 648  
 Craigie, I. C., 248  
 Cranes, 458  
 Crankshafts, 444-446  
 Craven, T. A. M., 652  
 Crescent Insulated Wire & Cable Co., 329  
 Cross License Agreement, 236-238  
 Crowell-Collier Publishing Corp., 127  
 Crown Fastener Div. of The Spool Cotton Co., 330-331  
 Curtiss-Wright Corp., 230, 260-265  
 Curtiss-Wright Corp., Propeller Div., 230, 331-333  
 Curtiss-Wright Technical Institute, 183-184  
 Cylinder deflectors, 438
- D
- Davidson, H. C., 75, 76  
 Davis, H. G., 642  
 Davison Chemical Corp., 333-335  
 Day bombing versus night bombing, 50-52  
 De Florez, L., 650  
 De France, S. J., 652  
 De-icer Equipment, 339-340, 438  
 Defense Plant Corporation, 277, 306, 321  
 Dehydrated packing, 438  
 Delta Airlines, 134, 135, 142, 146, 165  
 Denison Engineering Co., 335  
 Devers, J. L., 70  
 Dexter, R. R., 646

Diebold Safe & Lock Co., 335-336  
 Disconnect plugs, 440  
 Division of International Communica-  
 tions, 196  
 Donaldson, C. B., 656  
 Doolittle, J. H., 59, 61, 62, 69, 71, 143  
 Douglas, D. W., 642, 658  
 Douglas Aircraft Co., 217, 222, 257,  
 265-270  
 Dow Chemical Co., 336  
 Dowty Equipment Corp., 355  
 Dunn, R., 62  
 Dunton, D. H., 62  
 Duramold Div. of Fairchild Engine and  
 Airplane Corp., 336-338  
 Durand, W. F., 652  
 Durr, C. J., 652  
 Dynamotors, 442  
 Dzus Fastener Co., 338

E

Eagle Parachute Corp., 338  
 Eaker, I. C., 50, 53, 59, 70  
 Eastburn, G. B., 644  
 Eastern Aircraft Div., General Motors  
 Corp., 230  
 Eastern Airlines, 134, 135, 142, 146, 166  
 Eastman Kodak Co., 338  
 Ebel, W. K., 646  
 Echols, O. P., 648, 652  
 Eclipse-Pioneer, Div. of Bendix Avia-  
 tion Corp., 339-341  
 Edo Aircraft Corp., 163, 341-342  
 Ehrke, R., 164  
 Eighth Bomber Command, 54-61  
 Eisemann Corp., 342-343  
 Eisenhower, D. D., 62, 67, 70  
 Electric Auto-Lite Co., 343  
 Electrical Equipment, 346-347, 357, 365,  
 368, 394, 438-444; auxiliary motors,  
 440; disconnect plugs, 440; dyna-  
 motors, 442; generators, 442; gov-  
 ernors, 442; magnetos, 442; rectifiers,  
 442; relays, 442; rheostats, 442;  
 switches, 442; terminals, 442-444  
 Ellington, K., 664  
 Emanuel, V., 642, 664  
 Engine equipment, 444  
 Engine mounts, 444  
 Engine parts, 374, 444-446

Engineering and Research Corp., 343  
 Engines, increased power, 35; manufac-  
 turers, 306-316, 416-420  
 Enyart, W. R., 644  
 Equipment, improvements, 36-40  
 Europe, raids on, 52-60, 118  
 Evans, F. W., 648  
 Exact Weight Scale Co., 343  
 Exhaust manifolds, 446  
 Export Control, 204-206

## F

Fabrics, 446  
 Fairchild Aircraft Div. of Fairchild En-  
 gine & Airplane Corp., 270-273  
 Fairchild Engine and Airplane Corp.,  
 230, 270-273  
 Fairings, 446-450  
 Fanleads, 480  
 Farm Security Administration, 160  
 Farren, W. S., 234  
 Fasteners, 324, 326, 330-331, 338, 367,  
 369, 373, 388, 391, 450  
 Federal Communications Commission,  
 roster, 652; work of, 200-201  
 Federal Products Corp., 343  
 Fenwal Inc., 343-344  
 Filters, 317, 450-452  
 Finishes, 452  
 Fire Extinguishers, 358-359, 452  
 Firestone Tire & Rubber Co., 344-345  
 First aid equipment, 452  
 Fitch, W. S., 128  
 Fittings, 452  
 Flares, 355, 454  
 Fleet, R. H., 646  
 Fleetwings Div. of Kaiser Cargo, 273  
 Fleming, F. N., 644  
 Flex O Tube Co., 345  
 Flight Strips, 90  
 Floats, 341-342, 454  
 Fly, J. L., 652  
 Flying, magazine, 670  
 Flying Aces, 670  
 Foote Bros. Gear & Machine Corp., 345  
 Forest Products Laboratory, 202-203  
 Forest Service, 174; roster, 656; work  
 of, 201-204  
 Forgings, 359-360, 390, 395, 454  
 Forman, G. R., 646

Formica Insulation Co., 346  
 Francis, D., 648  
 Frank, W. H., 648  
 Fuel systems, airport, 454  
 Fuels, 378, 379-380, 385, 387, 454

## G

G & O Manufacturing Co., 346  
 Gardner, G., 648  
 Gardner, L. D., 646  
 Gaskets, 454-456  
 Gates, B. E., 648  
 Gears, 345, 456  
 General Aircraft Corp., 273-275  
 General Controls Co., 346  
 General Electric Co., 163, 234, 340-347  
 General Engineering Co., 347  
 Generators, 361, 442  
 George, H. L., 133, 648  
 George, J. J., 235  
 Germany, vulnerability to air attack, 24  
 Gilbert Islands Campaign, 91, 104-107  
 Giles, B. H., 648  
 Gilmor, R. E., 642  
 Glass, 456  
 Gliders, 256, 274-275, 294, 302, 305, 359;  
     manufacturers, 414  
 Globe Steel Tubes Co., 347  
 Glues, 456  
 Goad, L. C., 664  
 Goodrich, B. F., Co., 347-349  
 Gorrell, E. S., 642  
 Governmental activities, 193-216  
 Governors, 442  
 Govro-Nelson Co., 349  
 Graham, J. R., 644  
 Graham Rotary File & Tool Co., 349  
 Grant, D. N. W., 648  
 Grayson, G. H., 650  
 Gregory, A. T., 646  
 Gregory, H. F., 235  
 Grommets, 456  
 Gross, R. E., 642, 644, 658  
 Grumman Aircraft Engineering Corp.,  
     275-277  
 Guiberson Aircraft and Heater Div. of  
     Guiberson Diesel Engine Co., 349-350  
 Gunn, W., 83  
 Gyropilot, 381-383

## H

Haddaway, G. E., 648  
 Hale, W., 87  
 Hall, W. E., 648  
 Hallicrafters Co., 350-351  
 Halsey, W. F., 84  
 Hamilton, J. H., 156-157  
 Hamilton Standard Propellers Div. of  
     United Aircraft Corp., 351  
 Hanks, S. S., 90  
 Hardware, 430, 456-458  
 Harmon, M. F., 84  
 Harper, R. W., 648  
 Harris, J. W., 650  
 Harter, H. A., 664  
 Hartson, J. T., 644  
 Harvey-Wells Communications, Inc.,  
     353  
 Haskelite Manufacturing Corp., 353  
 Hawaiian Airlines, 134, 135  
 Hayes Manufacturing Corp., 353  
 Haynes, C. V., 71  
 Heaters, 370-371, 458  
 Heath Co., 353-354  
 Hedrick, L. H., 648  
 Helicopter, 41-42, 248, 278, 300  
 Hewitt Rubber Corp., Aircraft Prod-  
     ucts Div., 354  
 Hickey, R. F., 650  
 Higgins Aircraft, Inc., 262, 277-278  
 Hinterschr, J. F., 642  
 Hodges, A. C., 650  
 Hoists, 458  
 Horchler, B. H., 646  
 Hose, 458  
 Hose clamps, 395, 458  
 Hose fittings, 458-460  
 Houghton, E. F., & Co., 354-355  
 Howard Aircraft Corp., 278  
 Hoyt, K. K., 124, 128, 130, 131  
 Hub Industries, Inc., 183, 355  
 Hudson Motor Car Co., 280  
 Hunsaker, J. C., 652  
 Hunter, C., 642  
 Hydraulic controls and assemblies, 317,  
     460  
 Hyland Machine Co., 355

## I

India campaign, 71-80

Industrial Sound Control, 355  
 Inland Airlines, 134, 135, 142  
 Inspection equipment, 490-492  
 Institute of the Aeronautical Sciences,  
 roster, 646; work of, 233-236  
 Instructors, licensed ground, 704  
 Instruments, 329, 339-341, 343, 358, 359,  
 361-362, 375, 378-379, 381-382, 384-  
 385, 460-462  
 Insulating materials, 346, 462-464  
 Interdepartmental Quarantine Commis-  
 sion, 214  
 International Flare-Signal Div. of Kil-  
 gore Manufacturing Co., 355  
 International Technical Committee of  
 Aerial Legal Experts, 196  
 Interstate Aircraft & Engineering  
 Corp., 355-356  
 Inventions, 209-211  
 Ireland, G. S., 644  
 Irwin, R. R., 642  
 Italian campaign, 17-19, 66-67, 68-69, 91

## J

Jacobs Aircraft Engine Co., 309-310  
 Jacoel Cable Splicing Equipment Co.,  
 356  
 James, W. S., 646  
 Japan, 24; approaches to, 23  
 Jarvis Manufacturing Co., Southern  
 California Airparts Div., 381  
 Jeffries, John, Award, 235  
 Jessop Steel Co., 357  
 Jet propulsion, 40, 246-248  
 Johnson, E. L., 123, 124, 126, 128, 129,  
 130-131  
 Johnson, P. G., 642, 658  
 Joint Aircraft Committee, 193  
 Jones, G. D., 644  
 Jones, J. W., 648  
 Jones, Casey, School of Aeronautics,  
 184-185  
 Journal of Air Law, 670  
 Journal of the Aeronautical Sciences,  
 670  
 Jowain, Inc. Aircraft Div., 357

## K

Kaiser, H. J., 273  
 Kellett Aircraft Corp., 278

Kellogg Switchboard & Supply Co., 357  
 Kelly, R. D., 646  
 Kemper, C., 652  
 Kennametal Inc., 357-358  
 Kenney, G. C., 80, 82, 83, 162  
 Kent-Moore Organization, 358  
 Kharakhonoff, B., 254  
 Kidde, Walter, & Co., 358-359  
 Kilgen Aircraft Div. of Kilgen Organ  
 Co., 359  
 Kilgore Manufacturing Co., Interna-  
 tional Flare-Signal Div., 355  
 Kindelberger, J. H., 642, 644, 658  
 King, E. J., 92, 118-119, 650  
 Kingsley, C., 644  
 Kinner Motors, Inc., 310-311  
 Knerr, H., 59  
 Knox, F., 92, 112, 284  
 Koehler Aircraft Products Co., 359  
 Kollsman Instrument Div. of Square  
 D Co., 359  
 Kropp Forge Aviation Co., 360  
 Kuter, L. S., 17, 62, 648

## L

Landing gears, 324, 464-466  
 Landing lights, 464  
 Langley Memorial Aeronautical Labo-  
 ratory, 207  
 Larter, F., 656  
 Lasalco Inc., 360  
 Lawrance Aeronautical Corp., 360-361  
 Leach Relay Co., 361  
 Lee, J. C., 658  
 Leece-Neville Co., 361  
 Leland Electric Co., 361  
 Lewis, G. W., 652  
 Liberty Aircraft Products Corp., 361  
 Liberty Motors & Engineering Corp.,  
 361-362  
 Life saving equipment, 466  
 Lifts, 458  
 Link Aviation Devices, 362-364  
 Link-Belt Co., 364-365  
 Liquidometer Corp., 365  
 Littelfuse, Inc., 365  
 Little, D. M., 654  
 Littlewood, W., 652  
 Lockheed Aircraft Corp., 222, 278-283



Lockheed Employees Recreation Club,  
278  
Lockheed Overseas Corp., 278, 282  
Lodwick Aviation Military Academy,  
190  
Lodwick School of Aeronautics, 191  
Lord Manufacturing Co., 365  
Losey, Robert M., Award, 235  
Lothrop, E. E., 642  
Lovelace, W. R., 254  
Lovett, R. A., 42, 123  
Lubricants, 378, 466  
Lycoming Div., The Aviation Corp.,  
230, 311  
Lyon-Raymond Corp., 366

## M

McArthur, Warren, Corp., 366  
McAvoy, W. H., 235  
McCain, J. S., 92, 650, 652  
McClelland, H. H., 648  
McDonnell Aircraft Corp., 271, 283  
MacArthur, D., 81, 82, 86  
MacCraken, W. P., Jr., 644  
Machine parts, 468  
Machine Tools, 252, 319, 347, 357-358,  
371-372, 373, 377-378, 387, 388-390,  
394-395, 466-468  
Machinery, 468  
Macwhyte Co., 367  
Magnetos, 342, 377  
Maitan, J. J., 646  
Manifolds, 446, 468  
Manpower, *see* Aircraft manufacturing  
industry, manpower  
Manufacturers Aircraft Association,  
roster, 644; work of, 236-238  
Manufacturers Screw Products, 367  
Marchev, A., 642, 664  
Marshall Islands campaign, 91, 104-107  
Martin, G. L., 642, 664  
Martin, R. M., 650  
Martin, The Glenn L., Co., 230, 235,  
283-287  
Massachusetts Institute of Technology,  
383-384  
Mead, L., 164  
Mead, M., 146  
Mechanics, number of, 199  
Mediterranean campaign, 61-67

Mercury Aircraft Inc., 367  
Metal & Tool Reconditioning Service,  
367  
Meteorology, 214-216  
The Meyers Aircraft Co., 287-288  
Micro Switch Corp., 368  
Mid-Continent Airlines, 134, 135, 142  
Midway, battle of, 92  
Miles, A. C., 650  
Military air transport, *see* Air trans-  
port, military, 136  
Miller, L. W., 648  
Ministry of Aircraft Production, 246  
Mira Loma Flight Academy, 183  
Miscellaneous activities, 217-240  
Mitchell, William E., Memorial Award,  
301  
Model Airplane News, 670  
Modification centers, 144-145, 282-283  
Monogram Manufacturing Co., 368  
Montgomery, A. E., 107  
Montgomery, J. K., 61  
Moore-Eastwood & Co., 368-369  
Morgan, H., 71  
Morgan, J. E. P., 642  
Morris, J. P., 656  
Moseley, C. C., 183  
Moss, S. A., 234  
Motors, auxiliary, *see* Auxiliary motors  
Mountbatten, L., 75  
Mundorff, G. T., 650  
Munitions Control Unit, 204-206  
Murray, G. D., 177  
Murray, J. P., 42, 217, 642, 644

## N

Naiden, E., 71  
National Advisory Committee for  
Aeronautics, 34-35, 36-37, 384; roster,  
652; work of, 206-209  
National Aeronautic Association, ros-  
ter, 644  
National Aeronautics, magazine, 670  
National Air Lines, 134, 135, 142  
National Aircraft Standards Commit-  
tee, 217  
National Aircraft War Production  
Council, 222  
National Inventors Council, 209-211  
National Safety Council, 283

- National Screw & Manufacturing Co., 369-370
- Naval Air Transport Service, *see* Navy air forces
- Naval Aviation, *see* Navy air forces
- Navigation lights, 464
- Navy air forces, 91-122: Air Transport Service, 91: Airship Training Command, 177: Naval Air Transport Service, 118, 133, 136, 138, 139, 140-141, 143, 145, 146, 153, 154, 156: roster, 650: strength of, 91: training, 176-179
- Navy Department, 133
- Nelson, Herman, Corp., 370-371
- New England School of Aeronautics, 190
- New Guinea campaign, 80-83
- Nichols, W. H., 650
- Night bombing versus day bombing, 50-52
- Nimitz, C. W., 23, 93
- Norma Hoffmann Bearings Corp., 371
- Norris, E. W., 642
- North African campaign, 10-17, 19, 61-64
- North American Aviation, Inc., 222, 257, 288-293
- North Pacific campaign, 19-20, 87-90, 91, 102-103
- Northeast Airlines, 134, 135, 142
- Northern Aircraft Products Div. of Aviation Corp., 230, 371
- Northrop Aircraft, Inc., 222, 294
- Northwest Airlines, 134, 135, 140, 142, 146, 166
- Northwestern Aeronautical Corp., 294
- Numberall Stamp & Tool Co., 371
- Nuts, 450
- O
- O'Donnell, E., Jr., 71
- Office of Civilian Defense, 204
- Office of War Information, 29, 31-32, 292: report on air transport, 133-147: report on Civil Air Patrol, 125-126
- Office of War Mobilization, 222
- Official Aviation Guide, 670
- O'Hare, E., 112
- Oil seals, 468-470
- Old, W., 71
- Oldfield, H. R., 648
- Onsrud Machine Works, Inc., 371-372
- Oster, H. R., 650
- P
- Pace, E. M., 652
- Pacific Aviation, 372-373
- Pacific Div., Bendix Aviation Corp., 324
- Pacific Finance Corp., 278
- Packing, dehydrated, 333-335, 438
- Paints, 452
- Palmer, R. C., 221, 644
- Palnut Co., 373
- Pan American Airways System, 134, 135, 138, 139, 140, 142, 153-160
- Pan American-Grace Airways, 134, 135, 140, 142, 146, 160-161
- Panagra, *see* Pan American-Grace Airways
- Panels, 470
- Parachutes, 338, 353, 373, 386, 470: parts, 470
- Pardum, S. W., 650
- Parks Air College, 185-186
- Parrish, W. W., 648
- Parts, aircraft, 470-478: aluminum, 472-474; cork, 474; felt, 474; fibre, 474; leather, 474; magnesium, 474; plastic, 474-476; plywood, 476; rubber, 476; steel, 476-478; synthetic, 478; wood, 478
- Patents, 236-238
- Payne, J. H., 642
- Peabody, H., 648
- Peirse, R., 76
- Pennsylvania-Central Airlines Corp., 134, 135, 140, 142, 146
- Permanent American Aeronautical Commission, 196
- Permoflux Corp., 373
- Perrin, E. S., 648
- Personnel, *see* Aircraft manufacturing industry, manpower
- Pesco Products Co., 373
- Peters, W. F., 658
- Peterson, I. C., 642
- Philippines, 9
- Pilots, number of, 123, 198-199



Pioneer Parachute Co., 373  
 Piper Aircraft Corp., 295  
 Pistons, 446  
 Plastic bonding, 337, 353-354, 359  
 Plastics, 263-264, 283, 478  
 Plywood, 203-204, 271, 302, 336-338, 353, 359, 391-392  
 Polaris Flight Academy, 183  
 Pollard, R. E., 650  
 Pope, L. S., 650  
 Portal, C., 59  
 Porter-Cable Machine Co., 373  
 Postwar planning, 219-220, *see also* aircraft manufacturing industry, post-war planning  
 Power plants, auxiliary, 426  
 Pratt & Whitney Aircraft Div. of United Aircraft Corp., 311-312  
 Price, G. C., 648  
 Price, P. R., 642  
 Primers, engine, 478-480  
 Progress of Civil Aeronautics, 694-698  
 Propellers, 317, 331-333, 351, 480; parts, 480  
 Pruitt, R. S., 644  
 Pulleys, 480  
 Pumps, 340, 388, 454, 480  
 Public Health Service, 211-214

## Q

Quarantine, aircraft, 211-214

## R

R.A.F., 10-11, 12, 13, 14, 15, 24, 27, 50-52, 54, 183  
 Radiators, 346, 480  
 Radios, 482; accessories, 318-319, 323, 373, 378, 480-482; equipment, 350-351, 353, 393-394, 480-482; shielding, 325, 484  
 Raids, *see* Air raids  
 Ramsey, D. C., 116, 650  
 Ranger Aircraft Engines Div. of Fairchild Engine and Airplane Corp., 230, 312-314  
 Rectifiers, 442  
 Redding, W. P., 644  
 Redfern, M. F., 642  
 Reed, Sylvanus Albert, Award, 234  
 Reichelderfer, F. W., 652, 654

Reid, H. J. E., 652  
 Reinartz, E. G., 235  
 Relays, 322, 442  
 Remington Rand, 373-374  
 Republic Aircraft Products Div. of Aviation Corp., 230, 374  
 Republic Aviation Corp., 230, 295-297  
 Research, 206-209, 252-254, 271-272, 298, 307-308, 380, 386  
 Reynolds Metals Co., Aircraft Parts Div., 374  
 Rheem Manufacturing Co., 280  
 Rheostats, 442  
 Richardson, L. B., 650  
 Ring, S. C., 650  
 Rings, engine, 446  
 Rivets, 482-484  
 Roberts & Mander Stove Co., 374  
 Robertson Aircraft Corp., 297  
 Rochester Manufacturing Co., 374-375  
 Roebing's, John A., Sons Co., 375  
 Rogers, J. M., 644  
 Rohr Aircraft Corp., 375-376  
 Rommel, E., 11, 12, 13, 14, 15  
 Roosevelt, F. D., 124, 127, 167, 255  
 Roosevelt Aviation School, 186  
 Rosendahl, C. E., 177  
 Rotor aircraft, manufacturers, 410-414  
 Round-the-clock bombing, 52  
 Royal Air Force, *see* R.A.F.  
 Royal Aircraft Establishment, 234  
 Royal Canadian Air Force, 271  
 Royal Norwegian Air Force, 271  
 Royce, D., 650  
 Rubber Development Corp., 160  
 Russell, F. F., 221  
 Russell, F. H., 236, 644  
 Russell, J. S., 650  
 Ryan, T. C., 642, 658  
 Ryan Aeronautical Co., 222-223, 297-300  
 Ryan School of Aeronautics, 186-188

## S

SKF Industries, Inc., 376-377  
 Safety belts, 484  
 St. Louis Aircraft Corp., 300  
 Sanborn, J. A., 644  
 Sarle, C. F., 654  
 Scales, 343, 484

- Schrader's, A. Son, Div. of Scovill Manufacturing Co., 377  
 Scintilla Magneto Div., Bendix Aviation Corp., 377  
 Scott, R. L., Jr., 71  
 Scott Aviation Corp., 377  
 Scovill Manufacturing Co., A. Schrader's Son Div., 377  
 Screws, 450  
 Seats, 366, 484  
 Seybold Div. of Harris-Seybold-Potter Co., 377-378  
 Shadle, W., 656  
 Sharp, E. R., 652  
 Sheffield Corp., 378  
 Shell Oil Co., 378  
 Shielding, radio and ignition, 388, 484  
 Shims, 446  
 Shock struts, 354-355  
 Shop equipment, 365, 381, 484-486  
 Shure Brothers, 378  
 Sicilian Campaign, 17, 65-66, 91  
 Sidebottom, J. H., 642  
 Signals, 454  
 Sikorsky Aircraft Div., United Aircraft Corp., 300-301  
 Simmonds Aerocessories, Inc., 378-379  
 Skis, 454  
 Skyways, magazine, 670  
 Slessor, J., 70  
 Smith, D. F., 650  
 Smith, L. H., 664  
 Society of Automotive Engineers, roster, 646; work of, 238-240  
 Socony-Vacuum Oil Co., 379-380  
 Solar Aircraft Co., 380-381  
 Solomons Campaign, 91  
 Sommers, J. E., 656  
 South Pacific Campaign, 20-23, 83-87, 99-102, 108-110, 116-117  
 Southern Aircraft Corp., 301  
 Southern California Airparts, Div. of Jarvis Manufacturing Co., 381  
 Southern Flight, magazine, 670  
 Southwest Pacific Campaign, 20-23  
 Spaatz, C. A., 50, 59, 61, 62, 69, 71  
 Spark plugs, 323, 326, 486  
 Spartan Aircraft Co., 280, 301  
 Spartan School of Aeronautics, 188-189  
 Speas, D., 163  
 Speedway Manufacturing Co., 381  
 Spencer, L. V., 648  
 Spencer, R. E., 654  
 Spencer & Morris, 381  
 Sperry, E. A., Jr., 646  
 Sperry Gyroscope Co., 381-384  
 Sperry, Lawrence, Award, 235  
 Sperry Products, Inc., 384  
 Sportsman Pilot, magazine, 670  
 Spriessch Tool & Manufacturing Co., 384  
 Springs, 486  
 Stampings, 486-488  
 Standard Aircraft Products, 384-385  
 Standard Oil Company of California, 385  
 Stanley, R. M., 247-248  
 Stanton, C. I., 179, 197, 656  
 Starters, 339, 488  
 Stern, B., 656  
 Stewart, R. M., 181, 656  
 Stewart Technical School, 189-190  
 Stilwell, J. W., 71, 72  
 Stockburger, A. E., 656  
 Strainers, 450  
 Stratemeyer, G. E., 75, 76  
 Stresses, 203  
 Subassemblies, 344, 353, 375-376, 488  
 Summerill Tubing Co., 385  
 Sumners, H. W., 132  
 Superchargers, 488-490  
 Superior Tube Co., 385  
 Surface Combustion Div. of General Properties, Inc., 385-386  
 Swenson, L. H., 644  
 Switches, 442  
 Switlik Parachute Co., 386

## T

- Tail wheel assemblies, 490  
 Tanks, 354, 381, 490  
 Tannehill, I. R., 654  
 Tapes, 446  
 Taylor, I. H., 217  
 Taylor-Winfield Corp., 386-387  
 Taylorcraft Aviation Corp., 301-302  
 Tedder, A. W., 61, 64, 70  
 Terminals, 442-444  
 Testing Equipment, 335, 362, 490-492

Texas Co., 387  
 Thickstun, W. R., 654  
 Thompson Grinder Co., 387-388  
 Thompson Products, Inc., 388  
 Thurston, W. Harris, Inc., 388  
 Timm Aircraft Corp., 280-302  
 Tinnerman Products, Inc., 388  
 Tires, 344-345, 347-349, 492  
 Titeflex, Inc., 388  
 Tomkins-Johnson Co., 388-390  
 Tools, 328, 349, 358, 362, 392, 492  
 Towers, J. H., 23, 92, 650  
 Traffic control, *see* Airways Traffic control  
 Training, 171-192; Equipment, 362-364; Training, *see also* Air transport, training; aircraft manufacturing industry, training; Civil Aeronautics Administration, War Training Service  
 Transcontinental & Western Air, 134, 135, 140, 142, 146, 166-167, 279  
 Trippe, J. T., 154  
 Tube Turns, Inc., 390  
 Tubes, 492  
 Tubing, 347, 385, 388, 392, 492-494  
 Tunisia, 14  
 Tunisian campaign, 15-17  
 Turrets and parts, 494  
 Twining, N. F., 71, 84

U

U. S. Air Services, magazine, 670  
 Uniforms, 494  
 Union Aircraft Products Corp., 390  
 United Air Lines, 134, 135, 140, 142, 146, 167-170  
 United Aircraft Products, Inc., 390-391  
 United-Carr Fastener Corp., 391  
 United States Army Air Forces, *see* Army Air Forces  
 United States Navy, *see* Navy air forces  
 United States Plywood Corp., 391-392  
 Utica Drop Forge & Tool Corp., 392

V

Valk, W. E., 644  
 Valves, control, 346, 359, 372, 384-385, 494; engine, 388, 446

Vandeburg, C. M., 664  
 Vandenberg, H. S., 648  
 Varnishes, 452  
 Vaughan, G., 642, 664  
 Vega Aircraft Corp., 278  
 Veneers, 494-496  
 Ventilating equipment, 496  
 Vibration dampers, 496  
 Victor Metal Products Corp., 392  
 Victory, J. F., 652  
 Vinco Corp., 392  
 Vought, Chance, Div. of United Aircraft Corp., 183, 302-305

## W

WAC, *see* Women's Army Corps  
 WAVES, *see* Women's Appointed Volunteer Emergency Service  
 Waco Aircraft Co., 305-306  
 Wagner, F. D., 650  
 Wakefield, R. C., 652  
 Waldes Koh-I-Noor, Inc., 392  
 Walker, F. C., 650  
 Walker, P. A., 652  
 Walsh, R., 644  
 War, 9-28  
 War Department, 133  
 War Labor Board, 250  
 War Manpower Commission, 194, 224  
 War Production Board, 125, 194  
 Ward, J. C., Jr., 642, 664  
 Warner, E., 652  
 Warner, J. A. C., 646  
 Warner Aircraft Corp., 314  
 Washers, 450  
 Watts, L. F., 656  
 Weather Bureau, roster, 654; work of, 214-216  
 Weatherhead Co., 392-393  
 Weber Showcase and Fixture Co., 280, 393  
 Weems, P. V. H., 191  
 Weems System of Navigation, Inc., 191-192  
 Welding equipment, 496  
 Wellman Bronze & Aluminum Co., 393  
 Western Airlines, 134, 135, 140, 142, 146  
 Western Electric Co., 393-394  
 Western Flying, magazine, 670

- Westinghouse Electric & Manufacturing Co., 304  
Wheels, 496  
White, T. D., 648  
White, S. S., Dental Mfg. Co., Industrial Div., 394  
White-Rogers Electric Co., 394  
Whitman, R. P., 644  
Wichita Div., Boeing Airplane Co., 255  
Wichard, C. R., 656  
Wickes Brothers, 394-395  
Wieber, C. W., 650  
Wiggins, E. W., Airways, Inc., 190, 395  
Williams, G. M., 646  
Willoughby, A. O., 650  
Wilson, C. E., 193  
Wilson, E. E., 642  
Wilson, H. W., 70  
Windshield wipers, 496-498  
Wire, control, 375; electrical, 329, 498  
Women's Airforce Service Pilots, 149-150  
Women's Appointed Volunteer Emergency Service, 179  
Women's Army Corps, 150  
Woodhead, H., 642, 658  
Woods, L. E., 650  
Wright, O., 234, 652  
Wright, T. P., 193, 652  
Wright Aeronautical Corp., 310, 314-316, 384  
Wright Brothers Lecture, 234  
Wittek Manufacturing Co., 395  
Wyman Gordon Co., 395
- Y
- Yount, B. K., 648

