

AEROSPACE ECONOMIC INDICATORS

CURRENT

Total Aerospace Sales

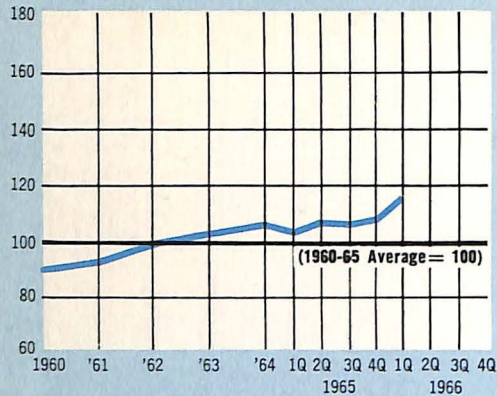

Value of Civil Aircraft Shipments

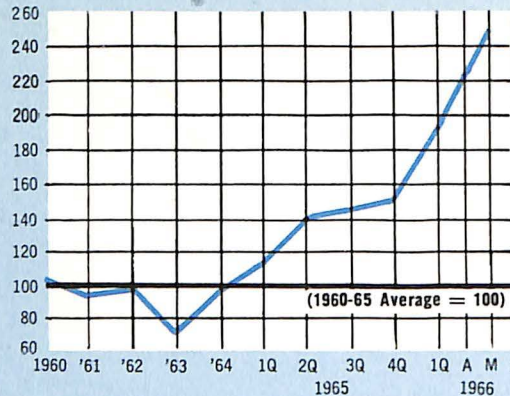

OUTLOOK

New Orders — Monthly Average

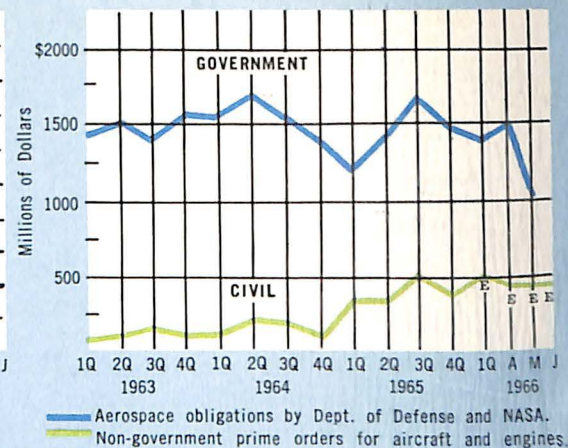

ITEM	UNIT	PERIOD	1960-65 AVERAGE *	LATEST PERIOD SHOWN	SAME PERIOD YEAR AGO	PRECEDING PERIOD †	LATEST PERIOD
AEROSPACE SALES: Total	Billion \$	Annual Rate	19.4	Quarter Ending March 31	20.0	20.9	22.4 [‡]
	Billion \$	Quarterly	4.8	1966	5.0	5.3	5.6
DEPARTMENT OF DEFENSE							
Aerospace obligations: Total	Million \$	Monthly	1,151	May 1966	914	1,247	785
Aircraft	Million \$	Monthly	601	May 1966	588	859	584
Missiles & Space	Million \$	Monthly	550	May 1966	326	388	201
Aerospace expenditures: Total	Million \$	Monthly	1,067	May 1966	938	1,016	759
Aircraft	Million \$	Monthly	561	May 1966	527	628	528
Missiles & Space	Million \$	Monthly	506	May 1966	411	388	231
NASA RESEARCH AND DEVELOPMENT							
Obligations	Million \$	Monthly	215	June 1966	404	296	378 [‡]
Expenditures	Million \$	Monthly	180	June 1966	379	485	436
UTILITY AIRCRAFT SALES							
Units	Number	Monthly	692	July 1966	985	1,396	1,093
Value	Million \$	Monthly	15	July 1966	28	38	30
BACKLOG (60 Aerospace Mfrs.): Total	Billion \$	Quarterly	15.3 #	Quarter Ending	15.9	20.4	22.4 [‡]
U.S. Government	Billion \$	Quarterly	11.6	March 31	11.6	13.7	14.4
Nongovernment	Billion \$	Quarterly	3.7	1966	4.3	6.7	8.0
EXPORTS							
Total (Including military)	Million \$	Monthly	110	June 1966	147	118	137
New Commercial Transports	Million \$	Monthly	24	June 1966	5	28	42
New Utility Aircraft	Million \$	Monthly	2	June 1966	9	9	9
PROFITS							
Aerospace — Based on Sales	Percent	Quarterly	2.3	Quarter Ending March 31	2.7	3.5	3.1
All Manufacturing — Based on Sales	Percent	Quarterly	4.8	1966	5.4	5.7	5.6
EMPLOYMENT: Total	Thousands	Monthly	1,132	June 1966	1,135	1,273	1,277 [‡]
Aircraft	Thousands	Monthly	499	June 1966	448	138	540
Missiles & Space	Thousands	Monthly	496	June 1966	518	164	566
AVERAGE HOURLY EARNINGS, PRODUCTION WORKERS	Dollars	Monthly	2.92	June 1966	3.14	3.39	3.39 [‡]

[‡] Estimate

* 1960-65 average is computed by dividing total year data by 12 or 4 to yield monthly or quarterly averages.

† Preceding period refers to month or quarter preceding latest period shown.

Averages for 1961-65.

AEROSPACE EXPORTS—RECORD AHEAD

Aerospace exports in 1966 are expected to reach a post-war record of \$1,550 million, an increase of more than five percent over the \$1,474 million reported in 1965.

This is the ninth year since World War II that aerospace exports have exceeded \$1 billion.

During the first half of the year, the export of \$238 million in U.S. commercial jet transports accounted for a substantial portion of the 5.4 percent increase in aerospace exports totalling approximately \$802 million. The increase in jet transport exports was 55 percent over the \$153 million in the corresponding period of 1965. By the end of the year it is anticipated that transport exports will exceed \$550 million.

Utility aircraft exports rose to \$47 million compared to \$32 million in the first six months of last year, a 47 percent increase. Foreign sales of these aircraft should rise to more than \$100 million by the end of 1966.

Export of aircraft engines and parts increased from about \$120 million in the first half of 1965 to more than \$143 million in the first six months of 1966, a 19 percent increase.

By 1970 it is expected that foreign demand for U.S. aerospace products may approximate \$2 billion annually if economic growth continues at its current pace. Some of the younger, developing nations are now beginning to make some impact on U.S. exports which will be even more pronounced in the early 1970s.

Such exports can be expected to continue to provide a significant contribution toward narrowing the deficit in the U.S. balance of payments.

Rising foreign demand for American aerospace products is the result of several factors:

- Higher incomes and economic growth in foreign countries have stimulated demand for air transportation thus increasing the purchase of aircraft. Many governments and private firms are now economically able and eager to buy many different types of aircraft and associated equipment.

- High U.S. productivity in the aerospace industry has helped to develop quality products with operating costs significantly lower than comparable equipment produced abroad.

- Expanded foreign sales programs by U.S. manufacturers have stimulated buyers abroad.

- A vigorous export financing program by U.S. banking and government institutions has been helpful in providing necessary credit availability for foreign nations in the purchase of aerospace products.

A recent AIA semi-annual survey of jet aircraft on order reveals that firm orders for U.S. jet transports abroad through 1970 will exceed \$1.3 billion. The impact of these orders on the U.S. economy is evident when it is realized that these orders will provide an additional estimated 70,000 jobs within the U.S. aerospace industry between 1966 and 1970.



aerospace

Official Publication of the
Aerospace Industries Association of America, Inc.

PRESIDENT • Karl G. Harr, Jr.

PUBLISHER • Glen Bayless

VOL. 4, NO. 7

SEPTEMBER 1966

EDITOR • Gerald J. McAllister

ASSOCIATE EDITORS • Richard W. Balentine

• William S. Evans

• John J. Lee

ECONOMIST • Gerson N. Chanowitz

ART DIRECTOR • James J. Fisher

CONTENTS

2 EARTH'S LAST FRONTIER

8 AEROSPACE NOTES

10 VIETNAM AND THE AEROSPACE INDUSTRY
— CHALLENGE AND RESPONSE

14 THE EXTRA MILE

By Karl G. Harr, Jr.

President, Aerospace Industries Association

The purpose of AEROSPACE is to:

Foster understanding of the aerospace industry's role in insuring our national security through design, development and production of advanced weapon systems;

Foster understanding of the aerospace industry's responsibilities in the space exploration program;

Foster understanding of civil aviation as a prime factor in domestic and international travel and trade;

Foster understanding of the aerospace industry's capabilities to apply its techniques of systems analysis and management to solve local and national problems in social and economic fields.

AEROSPACE is published monthly by the Aerospace Industries Association of America, Inc., the national trade association of the designers, developers and manufacturers of aircraft, missiles, spacecraft, their propulsion, navigation and guidance systems and other aeronautical systems and their components.

Publication Office: 1725 De Sales Street, N.W., Washington, D. C. 20036

Western Office: McCulloch Building, 6151 West Century Blvd., Los Angeles, Calif. 90045

*All material may be reproduced with
or without credit.*

Earth's Last

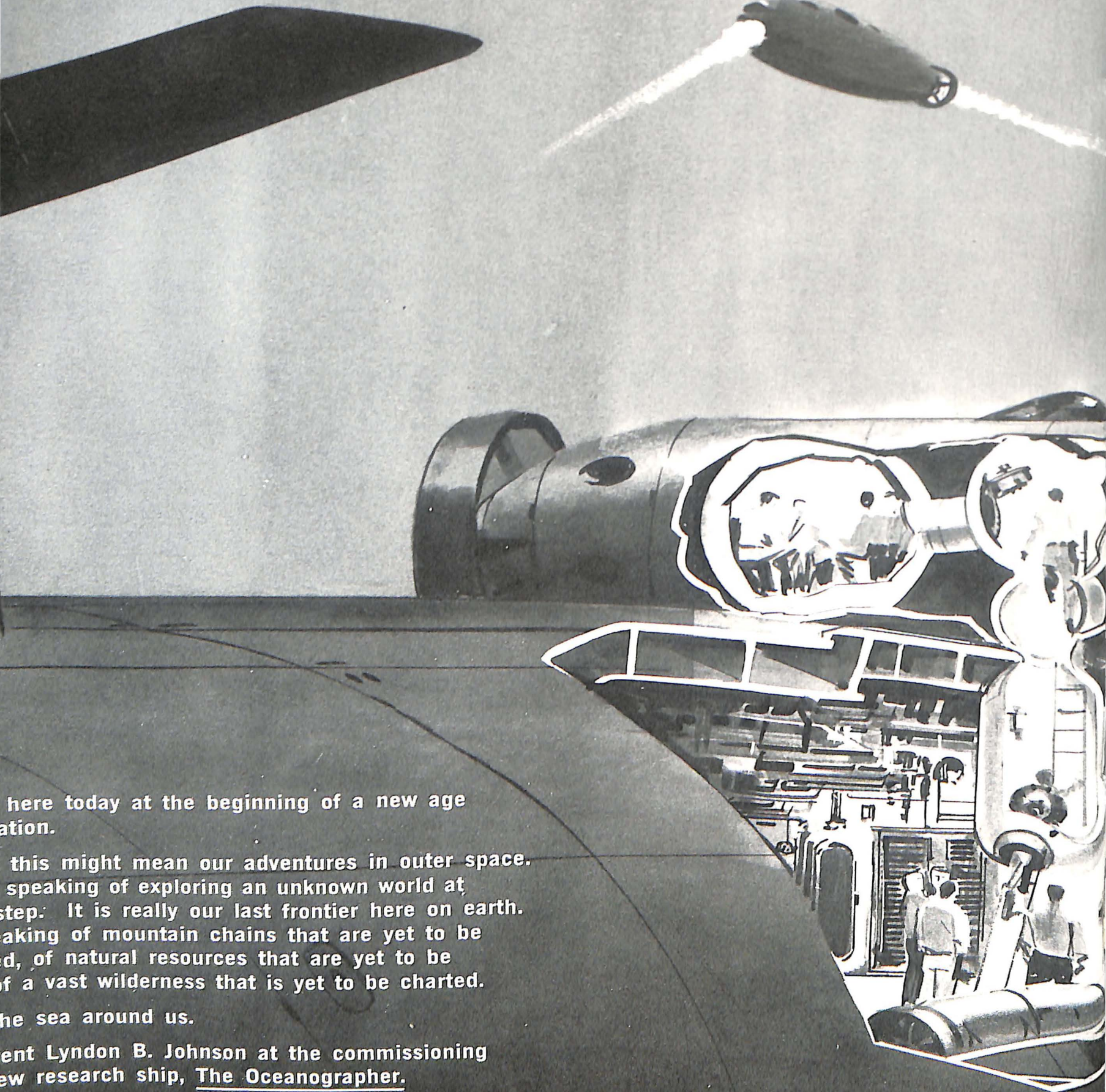

here today at the beginning of a new age
ation.

this might mean our adventures in outer space,
speaking of exploring an unknown world at
step: It is really our last frontier here on earth.
aking of mountain chains that are yet to be
d, of natural resources that are yet to be
of a vast wilderness that is yet to be charted.

he sea around us.

ent Lyndon B. Johnson at the commissioning
ew research ship, The Oceanographer.

Frontier

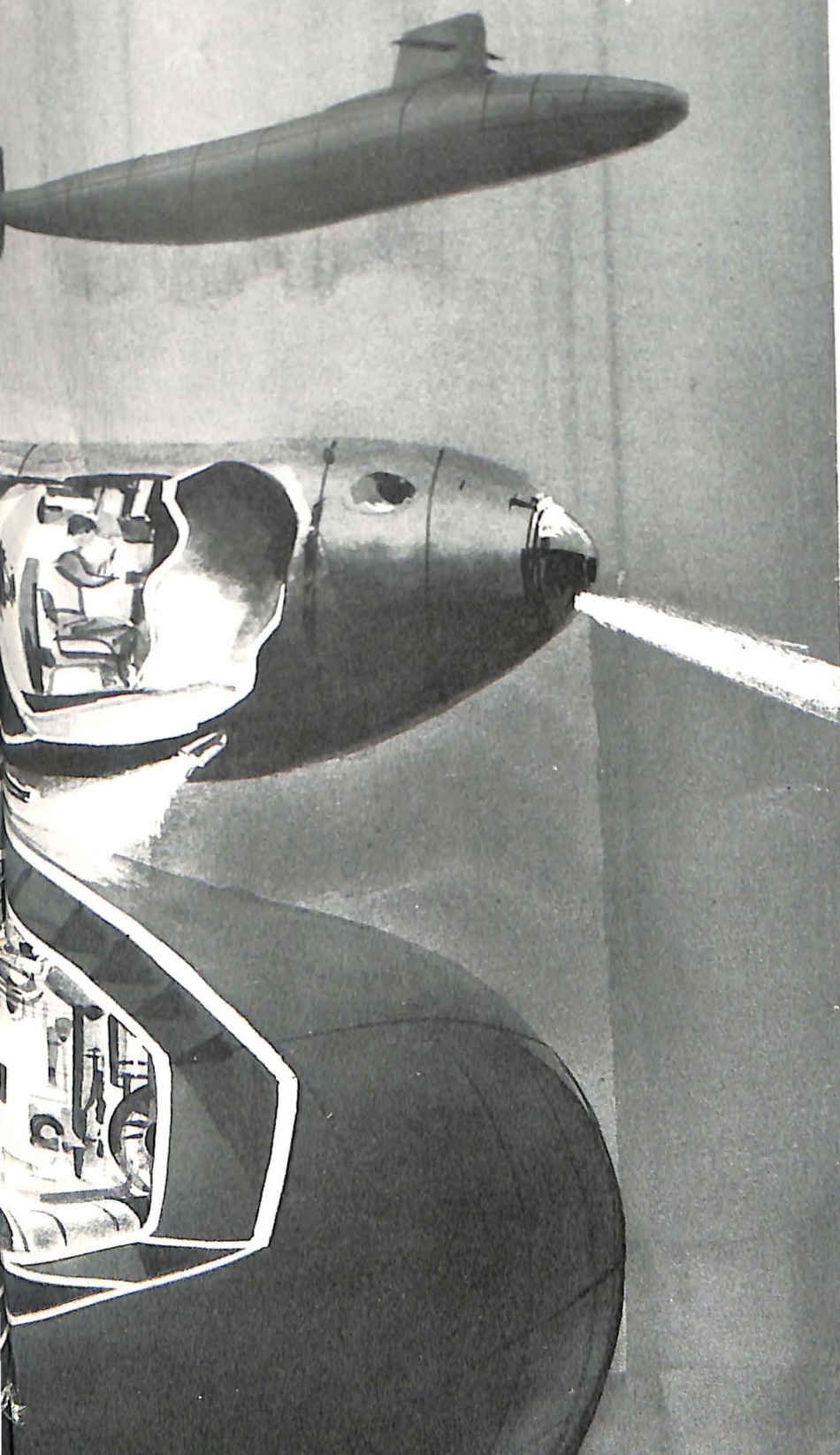

Oceanography is one of the fastest growing areas of research and exploration.

Federal spending on oceanography, now running about \$310 million a year, may well increase to \$1 billion or more in the next few years, including defense and civilian programs. President Johnson has stated that he will send a new oceanographic proposal to Congress in January. His instructions to the new council created by the Marine Resources & Engineering Development Act of 1966 are to produce recommendations by year's end.

To the oceanographic industry, made up largely of aerospace companies, the prospects are encouraging. There is justification for enthusiasm. Speaking at the commissioning of the newest and largest oceanographic vessel ever built by the U. S., *The Oceanographer*, President Johnson stressed the need to tap the oceans' secrets and resources. We are, he said, at the "beginning of a new era of exploration."

President Johnson added: "In the months ahead, we shall establish our priorities, we shall then set out timetables — and we shall follow them, just as we have followed an orderly and relentless program for the exploration of space."

The President also endorsed a new report just prepared for him by a top level group of technical advisers. The report, "Effective Use of the Sea," calls for an increase in federal dollars for oceanographic research from the present \$310 million level to over \$600 million by 1970. Defense efforts, too, run largely by the Navy, fall far short of what is needed with a sharp rise in spending required here, too, the report states. Federal funds for oceanography would be more than \$1 billion a year if their recommendations are carried out.

In order to achieve the goals of the report, a major governmental reorganization is proposed. Activities now included in the Environmental Science Services Administration, Geological Survey, Bureau of Commercial Fisheries and most of the oceanographic activities of the Bureau of Mines and Coast Guard should be combined in a single agency, the report recommends. The new agency would not be an oceanographic agency but would support a broad range of federal activities in the science and technology of the environment — land, sea and air — as well as fostering the development of oceanic resources.

Many companies, including Lockheed Aircraft Corp., Douglas Aircraft Company, General Motors, Aerojet-General Corp., The Boeing Company, Ford Motor Co., Westinghouse Electric Corp., General Electric Company, Grumman Aircraft Engineering Corp., General Dynamics Corp., United Aircraft Research Laboratories and others, as well as university oceanographic institutions, have been probing the oceans to learn more about them and the materials they contain.

Artist's conception on front cover shows a deep-diving research submarine equipped with a manipulator that will enable the craft to perform a variety of underwater missions. Two such ships are being built for the Navy by General Dynamics. Illustration on opposite page is a Deep Submergence Systems Project submarine rescue vehicle.

The expected yields from the oceans are staggering. In the vast bodies of water that cover nearly 75 percent of the earth's surface are contained more than enough foodstuff, chemicals, minerals and petroleum to meet man's future needs.

Only minor progress has been made so far to tap these riches. But this is changing. In a year when virtually every budget for federal agencies except defense was pared, funds for oceanography increased and major gains in knowledge will be made.

Programs underway to solve the mysteries of the oceans number in the hundreds. Some are huge multi-million dollar projects like the Navy's Deep Submergence Systems Project (DSSP); others are modest, costing only a few thousand dollars a year. The knowledge gained from all of them contributes toward a better understanding of the ocean environment and serves as the building blocks for other projects.

Perhaps the most spectacular program is being conducted by the Navy. Under its Deep Submergence Systems Project that will cost from \$200 million to \$300 million over the next few years, the Navy has a four-part program under which it plans to develop the capability to:

- By 1970, rescue personnel from stricken submarines in water depths well below 3,500 feet. This will gradually be extended. Today it is almost impossible to make submarine rescues much beyond 600-ft. water depths.

- Salvage large objects the size of a submarine or a destroyer in water depths of 600 feet or more.

- Perfect the equipment and techniques that will allow men to live and work on the ocean floor at 600- to 1,000-ft. water depths for several months—the man-in-the-sea program. This is being perfected under the Navy's Sealab program. Sealab I was lowered to the ocean floor in 192 feet deep water off Bermuda in 1964 with four men staying ten days. This was followed by Sealab II that was placed on the bottom of the ocean in 205 feet of water in 1965 off the coast of La Jolla, California, where it remained for 45 days. Twenty-eight men, working in three teams, lived and worked on the ocean bottom for 14-day periods with two of the aquanauts remaining down for 30 days.

Modifications are now being made to the Sealab II vessel; it will be put back on the ocean bottom as Sealab III next spring at a 500-ft. depth to extend man's underwater capability. By 1968, the Navy hopes to have a 40-man experimental colony of aquanauts living in a large ocean bottom structure to be known as Seahab 600 feet or more below the surface.

- Fourth goal is to develop a deep diving vessel that will allow men to search and recover small objects down to 20,000-ft. depths. To assist in this program, a small nuclear-powered submarine is being built. Though aimed primarily at Navy objectives, the program is valuable to all oceanographic work.

Another major effort is the National Science Foun-

ation's Project Mohole. Under this program that will cost over \$100 million before it is completed in the early 1970s, a hole will be drilled through the crust of the earth into the next structural layer known as the mantle. The mantle is estimated to be about 2,000 miles thick, extending from the earth's core to the relatively thin crust that is the surface of the earth, analogous to an orange with the peeling representing the earth's crust.

The upper part of this huge mantle is believed to be a prime influence on the development of earthquakes, volcanoes, and other forces that cause the earth to crack, islands to appear and disappear, and other phenomena.

The earth's crust varies widely in thickness with the thinnest areas located beneath the ocean. A drilling site near Hawaii has been selected. Water at this location is 14,000 feet deep. A hole through the crust over three miles deep must be drilled to tap the mantle. Preliminary drilling at other locations has already been done to evaluate equipment. The final drilling system is being built, and if all goes well, the drilling operations will be completed by 1970 or 1971.

In addition to the scientific data Project Mohole is expected to reveal, it will also make valuable contributions in techniques and equipment for tapping the vast pools of oil that lie beneath the ocean floors.

Along with these major programs, there are scientists and engineers conducting oceanographic work that is just as vital. There are now 113 research vessels either working full or part time on oceanography programs, and more are being built.

The ships and their scientists are spread around the world making surveys to chart accurately the ocean floors. Some are engaged in taking water temperatures at various depths, or testing the salt content in different areas; others are engaged in fish and mineral studies, the way sound travels underwater and other similar tasks.

Assisting the surface ships are a growing number of undersea vessels that take core samples of the ocean floor or collect rocks and mineral deposits. Some of these such as the Alvin and CURV (Controlled Underwater Research Vehicle) have been built by the government. But a growing number have been developed by companies largely in the aerospace industry.

Data on the ocean are being collected at a record pace, sent to the National Oceanographic Data Center in Washington, D. C., and placed on magnetic tapes so that computers can readily process all of the information known about any area of the oceans.

The task is just beginning, however. Three-fourths of the earth is covered by water ranging in depth from a few feet to several miles deep. There are layers of warm water on top of cold layers. Some areas contain more salt than others. Currents may flow in one direction on the surface only to have subcurrents flowing the opposite way. There are giant submerged moun-

tain ranges, valleys and canyons that run for miles. Currents alter the paths, mountains appear and disappear, and the water temperatures are continuously changing.

Initially, oceanographers are trying to learn more about the areas along the continental shelf that extend out from the United States in more or less gradual slopes to about 600- to 1,000-ft. depths. Gradually, however, they hope to know just about everything about the oceans, their geography, water conditions, and the food and minerals they contain.

Federal programs form the backbone of the oceanographic effort though they are supplemented by state and private industry projects.

There are nine government agencies directly supporting oceanography programs with several others indirectly involved. The primary agencies include the departments of: Defense, Commerce, Treasury, State, Health, Education & Welfare and Interior; agencies include National Science Foundation, Atomic Energy Commission and the Smithsonian Institution. Assistance comes from the National Aeronautics and Space Administration, the Federal Aviation Agency and others.

The Department of Defense's oceanographic work centers around Navy programs headed, primarily, by the U.S. Naval Oceanographic Office. Valuable contributions are made by other military branches,

The DIVING SAUCER oceanographic vessel is supported by supply vessel for off-shore oil wells. A hydraulic crane lowers and retrieves the vehicle.

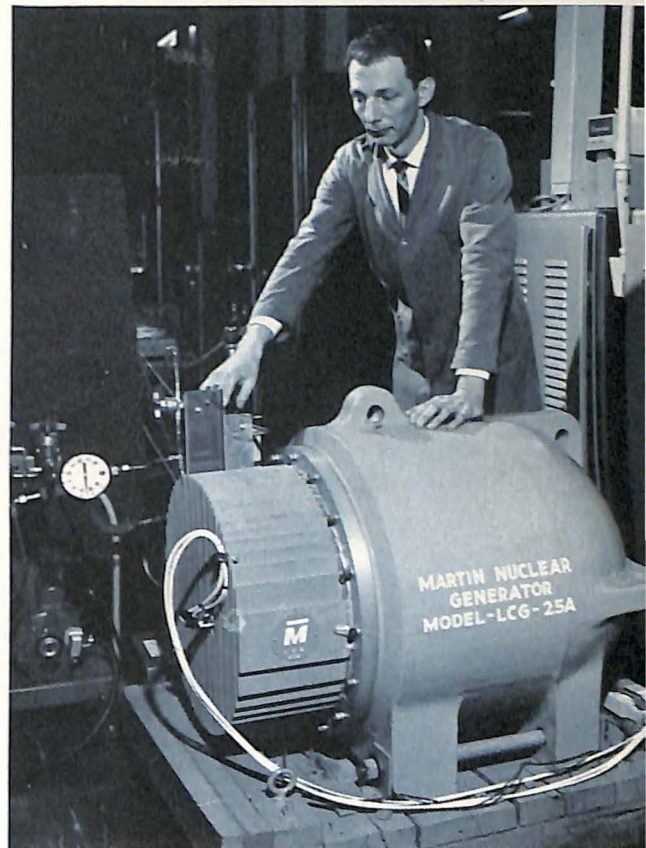

Martin Company nuclear generator will power an oceanographic measuring device in the Bering Strait, ten miles off the coast of Alaska. The generator is particularly suited for long-lived, unattended operation in isolated areas.

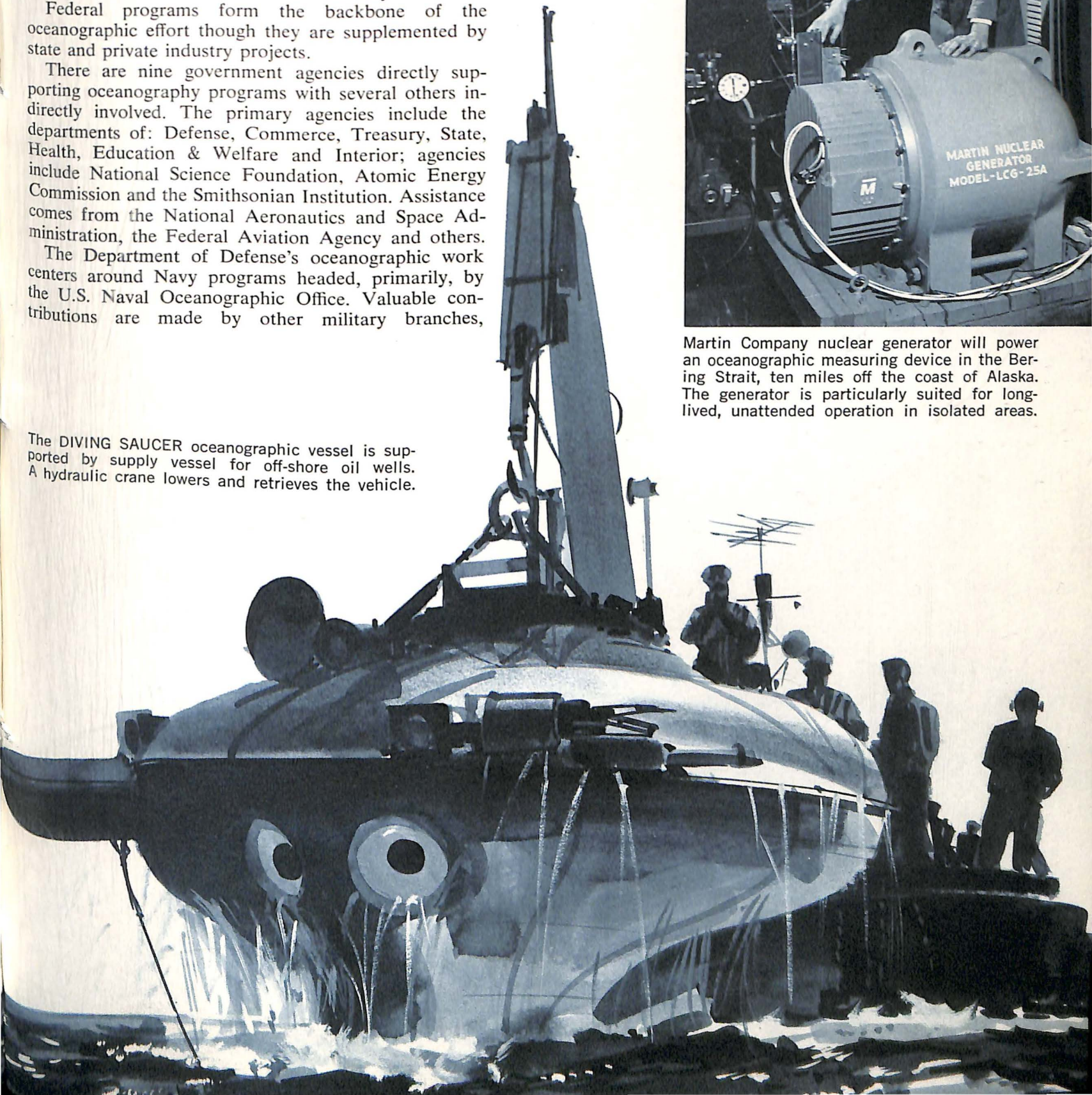

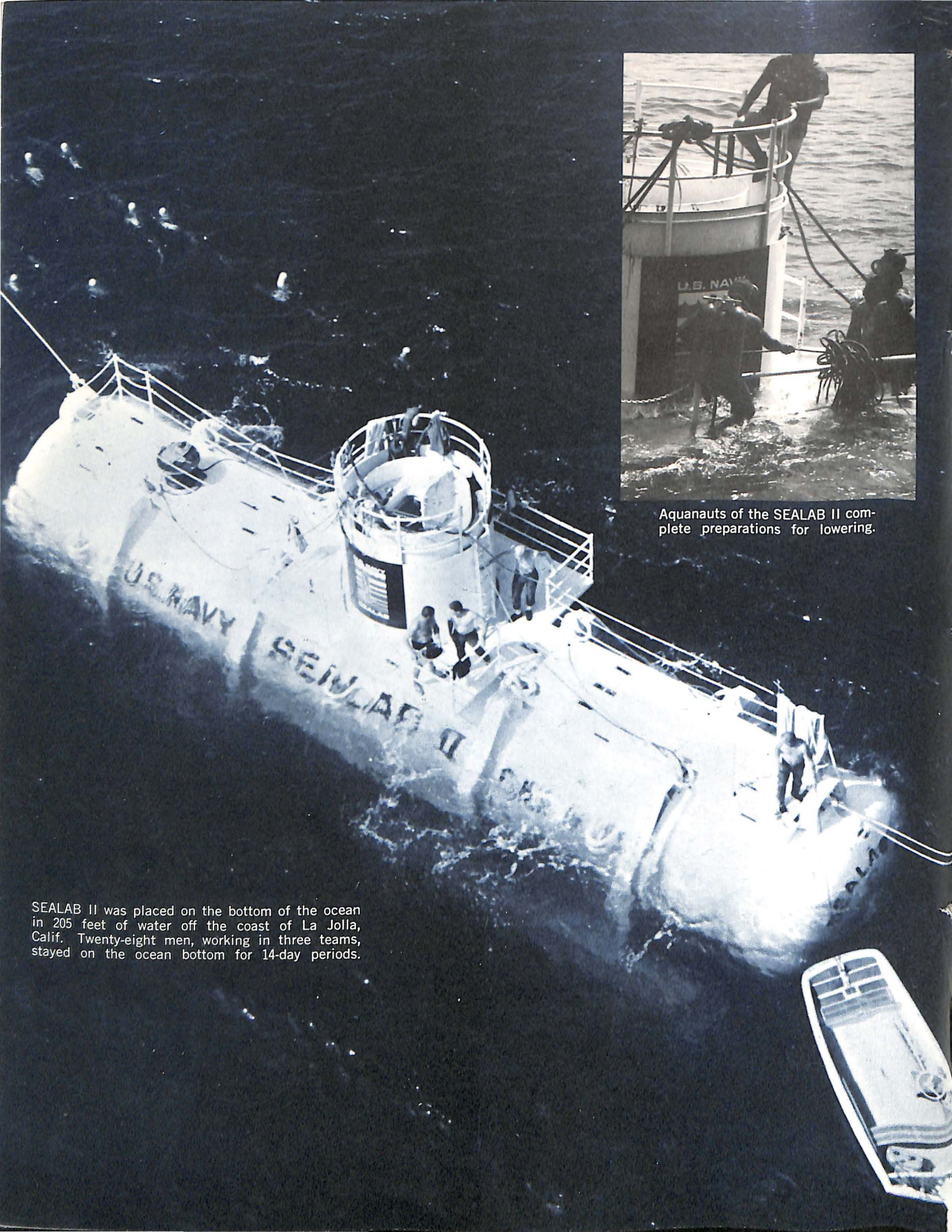

Aquanauts of the SEALAB II complete preparations for lowering.

SEALAB II was placed on the bottom of the ocean in 205 feet of water off the coast of La Jolla, Calif. Twenty-eight men, working in three teams, stayed on the ocean bottom for 14-day periods.

especially by the Navy's anti-submarine warfare programs. The Office of Naval Research funds oceanographic work done by 125 universities, non-profit institutions and private industry.

Work ranges from studying the chemistry of the oceans to studying the growth and decay of waves both at the surface and far below the surface.

The Department of Interior has programs to study the commercial fisheries both along the shallower continental shelf and the deep ocean. The National Science Foundation is supporting basic research into oceanography, managing Project Mohole, and lending support across a broad cross section of the national oceanographic effort.

The Atomic Energy Commission concentrates its efforts toward developing nuclear power sources that can be left unattended for long periods at remote areas on the surface of the oceans or far below on the ocean floor. They will power electronic devices collecting oceanographic data and transmitting them back to shore stations. AEC also studies the effects of dumping waste radioactive material in the ocean, background radiation and how these affect marine life.

The Department of Health, Education & Welfare studies the suitability of marine life as food sources, and monitors ocean pollution.

The Treasury Department, which administers the Coast Guard, studies icebergs — their movement patterns and how they break up and deteriorate.

The Smithsonian Institution studies the distribution of marine populations, organisms and sediments in the ocean. It is concerned with the nature and evolution of both living and non-living particles in the oceans.

The State Department largely supports work of international programs. There are eight international fisheries commissions, two of which, the Inter-American Tropical Tuna Commission and the International Pacific Halibut Commissions, have oceanographic fisheries research programs.

Supplementing the federal oceanographic programs are numerous state and private industry programs. Resort areas have long worked at devising ways to keep the ocean from eroding beaches. The oil industry has spent large amounts of money perfecting drilling techniques to tap the continental shelf oil deposits in the Gulf of Mexico, Alaska and California.

With an eye toward the future, many companies in the aerospace industry have created special oceanographic offices seeking ways in which they can become a part of the huge ocean research and exploration programs that are certain to come over the next decade.

Many companies have invested millions of dollars in perfecting deep diving research vessels that will be used for oceanographic exploration. Some are now used in government programs; others are engaged in company-sponsored research.

A large number of diverse companies are tailoring products to meet oceanographic needs. At the recent second annual Marine Technology Society meeting over 100 companies set up exhibits showing their line of oceanographic oriented products.

As oceanographic programs increase, there is a

demand for new and better tools. Equipment that works well in the atmosphere more often than not fails to perform underwater. Housing it in watertight containers isn't proving too successful, either. Oceanographic engineers are turning to designing equipment built especially for underwater use.

Most companies engaged in the work contend that the environment of the ocean is far more difficult to master than that of space. The water is always moving, sometimes slightly, at other times violently. Salt water is highly corrosive. Pressures are great as depths increase. On top of this, quips one engineer, "if these don't ruin your equipment, the fish will." Many electronic arrays placed in the ocean have been hauled out well chewed by sharks. One has even pulled that had been ruptured by a swordfish. Indeed, the swordfish, his bill speared through the cable, was there as evidence.

In its Sealab experiments where a helium atmosphere is provided for the aquanauts to breathe, standard equipment becomes permeated with the helium. It seeps through glass to fog television cameras and does other strange things.

Communicating to divers is another problem that as yet has not been solved successfully. At 300- to 400-ft. depths, visibility is sometimes no more than six to 12 inches. Divers use lights and sounding devices to find their way. Talking between divers is virtually limited to hand signals, Navy diving experts reported after the Sealab II experiment.

No one questions that eventually these problems will be solved as aerospace companies become more involved in oceanographic work.

PREDICTIONS FOR 1975

Rear Admiral O. D. Waters, Jr., Commander of the U. S. Naval Oceanographic Office, recently stated:

"I predict that by 1975 a great deal of our oceanographic survey work including such areas as water temperature, current patterns, shore erosion, ice movements and the like may be done by satellite or with at least satellite assistance. My office is already directing a sizeable study on this project.

"I predict that by 1975 submarines will be capable of operating routinely at 20,000 feet.

"I predict that by 1976 we will have colonies of aquanauts living and working at any place they choose on the continental shelf and at depths in the neighborhood of 1500 feet.

"And I predict that by 1975 we will have made big strides toward solving the fresh water problem and that there will be a possibility of bringing blossoms to desert areas."

AEROSPACE NOTES

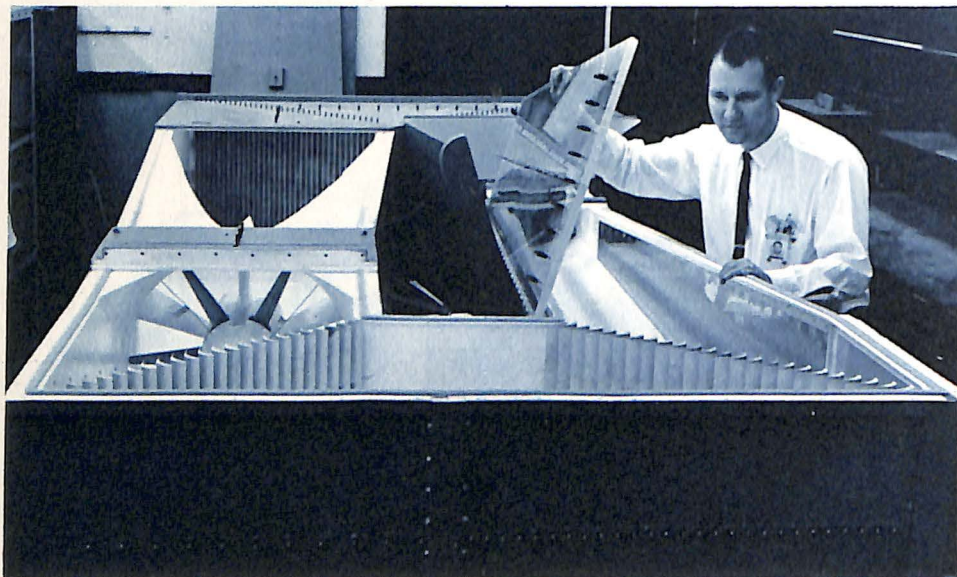

General Dynamics Develops Miniature Wind Tunnel

Convair Division of General Dynamics Corporation has devised a miniature wind tunnel one-twelfth the size of its full size low-speed wind tunnel which is proving a valuable aid for checking out improvements destined for the full scale tunnel.

Installations designed to improve air flow in the larger tunnel can be checked out in the smaller model for desired results before expensive changes are made in the big one. Air speeds in the smaller model are identical as are pressures. Some 1,100 pressure orifices ring the top, bottom, and sides of the model to measure pressure at any station along the center lines.

A motor-driven fan, rotating up to 12,000 revolutions per minute, produces the air current for the model's recirculating air flow. The 50 horsepower electrical motor which powers the fan is encased in a nacelle and water-cooled through tubes in metal struts.

Convair model shop workers fashioned the six wooden propeller blades by hand profiler from 1/8 inch laminated maple strips.

Air is circulated around the tunnel by the fan through four sets of aluminum turning vanes which direct it around the corners of the rectangular-shaped tunnel.

After passing through the test sections, air is directed back to the fan for recirculation.

North American Laser Beam 'Writes' on Tiny Film

The entire contents of the Library of Congress could probably be stored in an area less than that occupied by three office desks if photographically recorded by means of a new laser image generator developed by North American Aviation's Autonetics Division at Anaheim, Calif.

The light beam from a helium-neon laser, focused to a spot 0.0004 inch in diameter, "writes" lines on a fine-grained, high resolution photographic film. The closely spaced lines form an image on the film in a manner similar to a television picture. Only one ten-thousandth of a watt of light power is necessary to form the photograph.

Included in the device is a laser scanner which "reads" previously developed photographs and generates electrical signals as it scans the film line by line.

With this technique, high-quality photographs taken on an aircraft in flight may some day be transmitted to a distant ground station within seconds after their development, or photographs of the planets taken by cameras aboard distant spacecraft might be read out, transmitted to earth, and then recorded without loss in picture quality.

Autonetics claims the device is capable of recording all the image detail of a normal television picture on one-tenth square inch of film.

The recorder is to be delivered to the Air Force for further evaluation.

Honeywell Devises New Magnetic Tape System

A new multi-purpose magnetic tape system known as the Honeywell 7600 has been developed by that company at its Denver, Colo., Test Instruments Division.

Designed for aerospace, medical and industrial applications, the 7600 provides direct recording of data and digital recording to 1,000 bits (characters) per inch density at speeds automatically synchronized and selected by push button.

Precision printed-circuit motor assembly eliminates belts, pulleys and gears, and tape alignment or mechanical adjustments are unnecessary.

The system has seven tape speeds ranging from 1 7/8 inches to 120 inches per second and accommodates quarter-, half- and one-inch tape on reels up to 15 inches.

Electronic subassemblies are plug-in modules for easy, on-site maintenance and replacement by the user.

RCA System Supplies Lunar Orbiter Power

Power and communications for the National Aeronautics and Space Administration's Lunar Orbiter will be supplied by systems designed and developed by Radio Corporation of America at its Astro-Electronics Division, Princeton, N.J.

The power system will supply all the electricity needed to operate the 850-ton spacecraft during its 30-day mission as it orbits the moon photographing possible sites for later Apollo landings. In addition, the power system will operate for at least another year while the spacecraft is orbiting for refined measurements of lunar

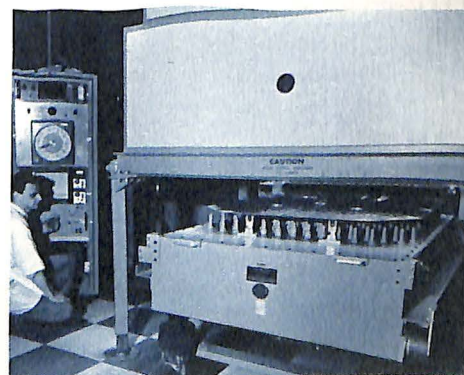

gravitational fields, collecting radiation measurements, detecting meteoroid bombardment data and other scientific information. The Boeing Company is prime contractor for the Lunar Orbiter.

RCA's communications system for the Orbiter will make possible the transmission of photographs from orbit to earth on command. It will permit reception of clear video signals despite the presence of high intensity interfering noise, and will process and transmit back to earth photographs taken by a dual lens photographic system.

Photo shows test of one of four solar panels in the power system to determine its ability to produce electricity from sunlight.

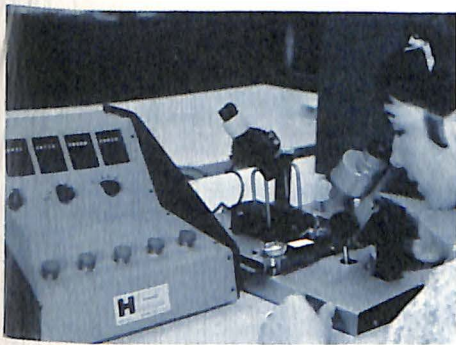

Hughes Instrument Tests Semiconductor Devices

Hughes Aircraft Company's Microelectronic Circuits division is marketing a new instrument for testing "flip chip" semiconductor devices.

The tester provides a more reliable and accurate method of electrically testing the devices than is possible with the conventional needle type probes. Positive contact is made during testing through the "pad contact" method.

The tester provides accurate alignment and placement of a semiconductor chip onto the test pads. The chip then is lifted by a vacuum pickup and placed with its bumps, or metallized lands, face down, onto flexible pads.

After the test, an electro-mechanical push-button control allows the operator to select the proper sorting bin and automatically counts the tested devices. Standard machines are equipped with five bins and four contact pads but special controls to handle additional multi-bump devices and automated sorting can be provided as required.



Sperry Rand Integrates A-7A Avionics Systems

Sperry Rand's Gyroscope Company Division is developing a new generation avionics system for Navy's advanced A-7A Corsair II light attack aircraft. The system, known as the ILAAS (integrated light attack avionics system), will perform all the major electronics functions of the aircraft. The A-7A is manufactured by Vought Aeronautics Division of LTV Aerospace Corp., subsidiary of Ling-Temco-Vought, Inc.

ILAAS will be the first fixed-wing aircraft avionics system to fully integrate navigation, central control, communications, weapon delivery, and displays through a Computer Control Complex which will govern the entire ILAAS system through digital control and computation processes. To enhance system reliability, the CCC consists of redundant computers.

ILAAS will incorporate functional modularity so that subsystem functions can be added to or removed without affecting the rest of the system. This also allows ILAAS to adapt to changes in weapon technology or other mission applications.

Four prototype systems will be built, two of which will be flight tested during the latter part of 1967.

Boeing Builds Automatic Heat Test Regulator

Engineers at The Boeing Company have developed a precision non-linear compensating temperature regulator for use when experimenting with the effects of extremely high temperatures on metal structures and alloys.

The new regulator automatically ad-

justs dials for the engineer during a heat test. Thus, dial settings need to be made only once. The temperature regulator's compensating circuit will maintain the desired temperature across the test surface regardless of convection, conduction and radiation losses.

The new Boeing regulator is made up of two separate control systems. One is made up of a differentiating circuit and a regenerative feedback circuit which calculates and applies the correct amount of power to offset thermal losses of the specimen. The second system detects the slightest error between the desired temperature and the actual temperature, adjusting the power level to correct this error.

Used in series, the new temperature regulator can hold the heat levels of two or more sections of the same piece of material at two or more different temperatures.



VIETNAM AND THE AEROSPACE INDUSTRY- CHALLENGE

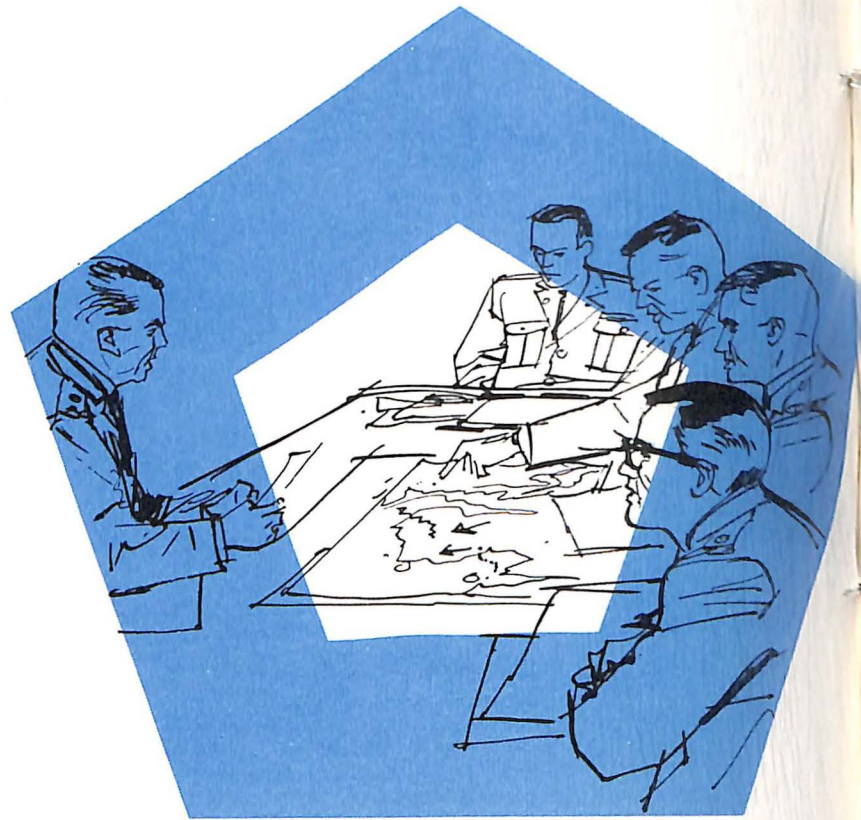

As the C-123 touched down on Tan Son Nhut's one long runway, its landing gear gently folded and two big props began biting at the concrete. The troop transport crunched to a stop at the 5,000-foot marker, effectively closing one of the world's busiest airports. Viet Cong gunfire had drained hydraulic fluid from the aircraft's landing gear.

A flight of three North American F-100s orbited overhead, their pilots nursing fuel while a crane lumbered toward the C-123. The crane pushed a steel "A-frame" which dangled slings of the sort marinas use to hoist boats from the water. Airmen positioned several slings under the plane's belly, the crane began to tug and in 20 minutes Tan Son Nhut had reopened for business. "Redwing flight cleared 360 degrees overhead, caution crane on left side of runway," radioed the tower. Three F-100s landed, short on fuel, but safely.

AND RESPONSE



Behind the A-frame and its peculiar slings is a story — a story of how Vietnam has challenged the U.S. aerospace industry and industry's quick response to that challenge.

On Nov. 24, 1965, teletypes in the Pentagon printed a message from the U.S. 2nd Air Division headquarters at Tan Son Nhut Air Base in the Republic of Vietnam. It began, "This is a SEAOR (Southeast Asia Operational Requirement) message," thus alerting the Air Force that its men in Southeast Asia had an urgent operational requirement — perhaps for a new, special-purpose gunsight, or for light-weight flying boots, or for an aerial camera to assess strike damage. In this case, they needed a tool to clear runways.

Without properly sized slings available, the SEAOR pointed out, "it is necessary to push a crash-damaged aircraft off the runway with heavy construction equip-

ment. This further damages the aircraft. This problem is especially serious at South Vietnam air bases with only one runway."

The requirement: A universal sling, one that could haul away all types of Army, Navy, USAF fighter, reconnaissance, utility and cargo aircraft, up to C-123 size, from their resting place on an active runway. An aerospace firm built the answer.

By April, four months after Headquarters USAF, the Tactical Air Command and Air Force Systems Command received the SEAOR message, and laid down specifications, eleven of the big slings had been delivered to air bases in South Vietnam. Clogged runways, once a major problem, became more of a nuisance as the slings began lifting away damaged aircraft.

Consider another example of industry-Air Force teamwork. The tactics of air-to-air and air-to-ground

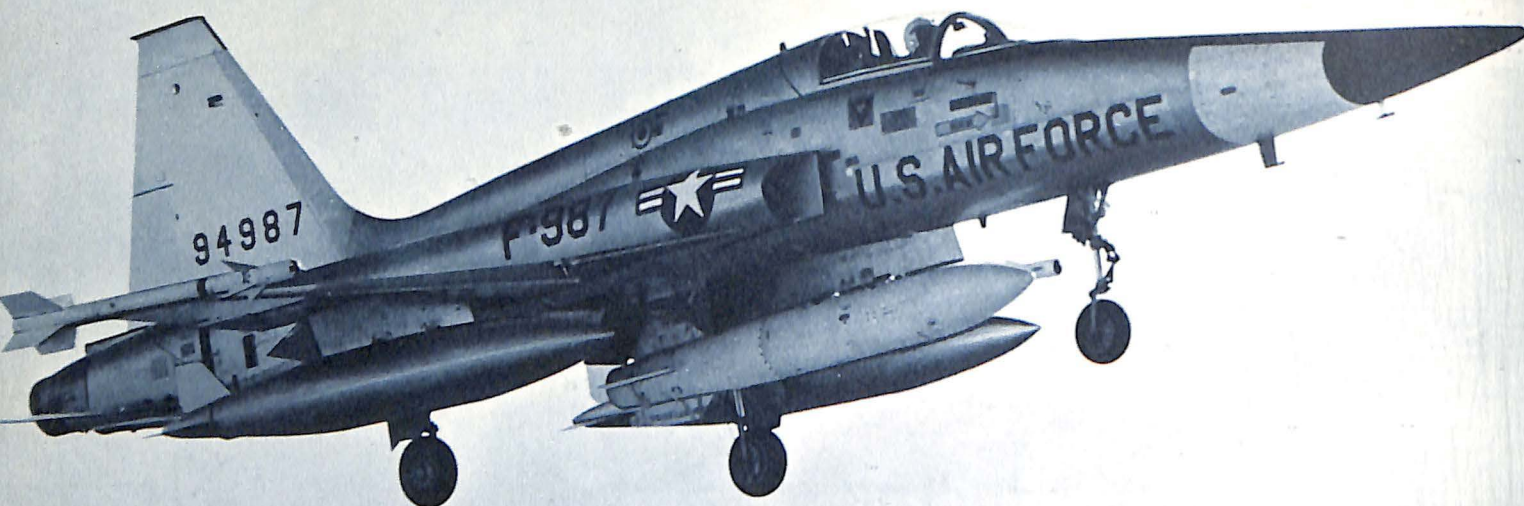

Northrop F-5 received a thorough testing with the Skoshi Tiger squadron. Combat experience showed a requirement for a strike-assessment camera and a dorsal fuel tank.

combat change daily with the weather. What kinds of bombs should be stowed aboard Boeing B-52s? What kinds of air-to-air missiles should the fighters haul aloft? How much top cover must be supplied F-100s striking targets in North Vietnam? Can that ambushed company be extricated by helicopter? Each question is automatically followed by another: What's the weather? And a SEAOR is to answer it.

Sometime this Fall, three long-range radars built by the Raytheon Company will begin keeping a weather watch on the entire Indochinese Peninsula, some 200,000 square miles of it. The height of cumulonimbus near the Chinese border, the intensity of monsoon thunderstorms, cloud cover above Haiphong—all will be read out in real time at fighter and bomber operations. Not only can the radar "see" cloud tops as high as fifteen miles, it can plot the movement of whole storm systems. Weather forecasting from Saigon will soon match New York forecasting accuracy.

As of July, ninety-three Southeast Asia Operational Requirements had been generated by the Air Force in Vietnam. Twelve have been fulfilled, the hardware or the requested modification at work in the theater. Whereas it traditionally takes five to ten years to develop a major weapon, the Air Force says the average time to complete a less-complicated SEAOR is down to about nine months. Of the ninety-three SEAORs received, fifty-nine are classified "active," and twenty-two have been canceled as unworkable, too costly to justify or impossible to develop on very short notice.

But the high-speed SEAOR pipeline is just one of several set up by the military to conceive new tools of war and race them from the factory to their users. If most SEAORs are born at squadron level, the ideas of airmen, most "Project 1559" items are suggested by private industry.

Under Project 1559, which was set up last year, Air Force Systems Command can buy and test limited war concepts proposed by the aerospace companies, and, in

the process, sidestep cumbersome procurement procedures. AFSC cannot authorize large-scale production of 1559 hardware, but it can fund promising ideas on a research and development basis, buying prototypes and sample quantities as quickly as industry can produce them. These are not normally huge projects—the average project cost is about \$100,000—but they are important and dividends come quickly. The mean time between identification of a 1559 "task" and its fulfillment is running about four months.

The tasks included:

Air Force needed to know whether Northrop's F-5 could become a workhorse close support and interdiction aircraft in Vietnam. Project 1559 enabled Northrop to refit the "Skoshi Tiger" test squadron with new strike-assessment cameras. With a budget of about \$6 million, 1559 also allowed development of a special grenade launcher for a rifle, a chemical spray to hold down the dust on unprepared landing strips, a kind of disintegrating parachute that proves useless in the hands of scavenging Viet Cong, and a portable "instrument landing system" that enables pilots to judge their height above the jungle canopy as they approach short, unprepared front-line landing strips. At least 100 comparable efforts have been begun or completed by AFSC under Project 1559.

In one sense, the war in Vietnam pits science and technology against a classic guerrilla force which travels light, lives off the land and counters firepower with cunning. To harness technology to the requirements of Vietnam, the Defense Department has created a new management structure.

Prior to April, 1964, the Air Force, the Army, the Navy and the Advanced Research Projects Agency conducted separate test and evaluation activities in Southeast Asia. Their efforts, however, were largely uncoordinated. The agency created to pull together the entire Vietnamese R&D activity was called JRATA (Joint Research and Test Activity) and in two years,

it has forged a link between combat units in the field and the vast stateside R&D apparatus. Working in Gen. William C. Westmoreland's Saigon headquarters are about 175 JRATA scientists, officers and engineers and professors, among them anthropologists, political scientists and others whose professions have no apparent relationship to prosecution of a war.

JRATA's job? Handling on-the-spot problems that arise in Vietnam and must be solved *there* instead of in Panama or Thailand, which have jungles but no Viet Cong. It advises field commanders on the status of recommended research projects under way in the United States. It aids the stateside R&D community by furnishing detailed information on the Vietnamese combat environment. It studies the organizations of field units: for example, should an infantry platoon be reshuffled to include extra mortarmen prior to a specialized mission?

But equipment routed through JRATA for use in the field must first be tested thoroughly in the United States. "We don't test out here," one JRATA official said: "We use."

Sometimes, however, the military can identify a critical need in Vietnam but must proceed from scratch in building the weapon or devising the modification to fulfill it. To shorten development time, snip red tape and speed the pipeline, the Defense Department conceived Project PROVOST (Priority Research Objectives for Vietnam Operations Support). Before a project gains PROVOST status, the DoD must decide it can be completed in eighteen months or less, with one exception: Anything sought by Gen. Westmoreland automatically goes to PROVOST.

Once marked PROVOST, a project gets special financial attention. Although PROVOST was only funded at about \$75 million in the Fiscal 1967 budget, it's supported somewhat indirectly by the Defense Department's emergency fund and the supplemental appropriations. At least \$200 million has been spent on

projects given PROVOST priority, for example:

F-4 pilots complained they could have downed two attacking MIG-21s, had their Phantoms been equipped with nose-firing cannon. The pilots argued their case persuasively, emphasizing the futility of firing missiles in certain air-to-air situations. As a result, under PROVOST, a classified number of F-4s were returned to McDonnell's St. Louis factory for installation of nose-firing cannon.

This summer, a House Armed Services Subcommittee returned from a fact-finding trip to Vietnam and reported several critical material gaps in the arsenal available in Southeast Asia. We need, the lawmakers, said, the following:

- People sensors. Technology can perhaps spot the invisible enemy as he hides in thick jungle or in tunnel networks underground.
- Protection from dust. As effective as the helicopter is in Viet Nam, dust can force overhaul of engines every 300 hours, whereas the same engines last up to 1,600 hours in the United States.
- Long delay fuzes. Too many bombs are wasted because they explode atop the jungle canopy, which the fuze thinks is ground.
- A COIN aircraft. Aviators continue to urge development of a new counter-insurgency plane that could do triple-duty in Vietnam — in close support strikes, light transport and armored spotting.
- Anti-truck bombs. Ordnance should be developed that can close down supply routes for longer periods than the brief time the attacking aircraft are overhead. Sprinkling small bombs with delayed-action fuzes across the so-called choke points was a suggested solution.

Several of these projects are being pushed with PROVOST money. Others have been accepted by JRATA. These, then, are the channels along which move the urgent *demands* from Vietnam. *Supply* comes from the aerospace industry.

McDonnell F-4 has been used extensively in Vietnam by the Air Force and Navy. A nose-firing cannon has been added to some F-4s to aid in combat with MIG-21s.



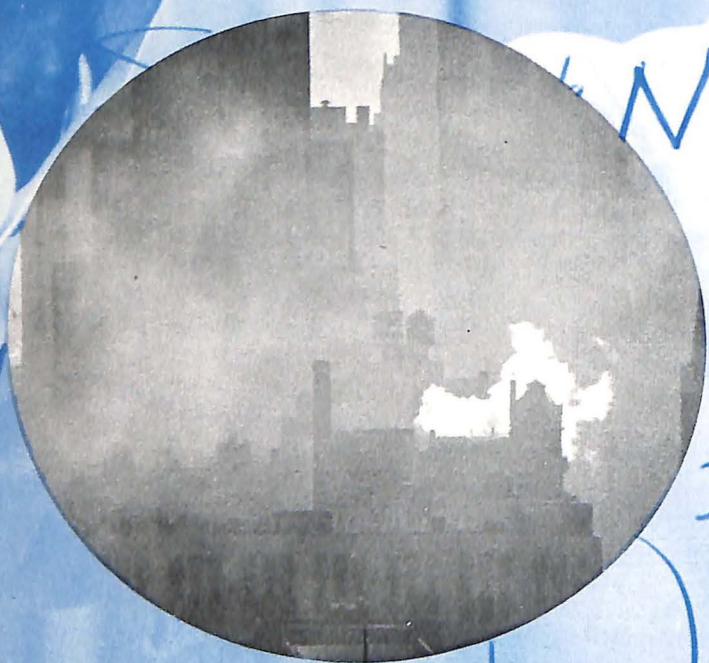
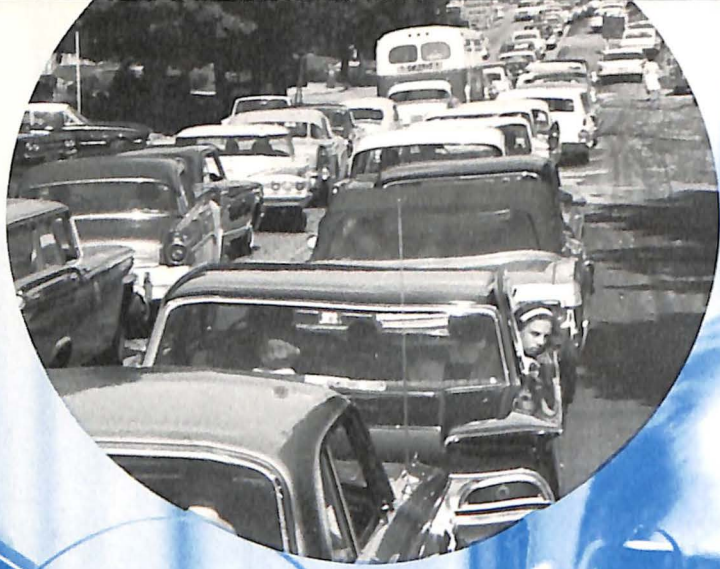

A large, blue-tinted background image of a man wearing glasses, a white dress shirt, and a dark tie. He is looking slightly to the right. The image is overlaid with various hand-drawn annotations in blue ink, including circles, lines, and text. A hand on the left holds a pen, pointing towards a circle containing the letter 'M'. Other circles contain 'M.', 'M', and 'fit'. There are also some numbers like '10', '11', '10', and '0000' scattered around. The overall aesthetic is that of a technical or scientific diagram or report.

THE EXTRA MILE

The following is excerpted from a recent speech by Karl G. Harr, Jr., president of the Aerospace Industries Association, before the Chaparral Club in Dallas, Texas.

During the last decade America has been embarked on a new industrial revolution with an impact on the destinies of men and nations potentially as great as that which so radically altered men's lives in the 18th and 19th centuries.

Certainly the nature and dimensions of this revolution are not easy to grasp. Those of us in the aerospace industry often tend to be a little too close to the trees to comprehend the forest; and outside observers often sense but cannot quite accept the dimensions of what has taken place. Compounding the confusion is the fact that, with the collapse of time and space forms which has taken place since World War II, what required two centuries to occur before has now occurred in a few years. But we must grasp that fact soon if we are both to exploit the potential of this new industrial revolution and avoid or at least mitigate its disruptions. For in the most important terms of all — human terms — both major opportunities and major disruptions are potentially present in abundance.

The core of this revolution is a galloping technological advance coupled with radically new techniques for its systematized application to problems of almost infinite complexity.

It is not necessary to belabor the point that the aerospace industry is in the vanguard of this revolution. In fact that is what today's aerospace industry is all about. It is an industry not primarily of products but of highly developed and rarified capabilities which are having their impact throughout the nation's industrial economy. It is precisely this change in its nature, occurring over a very few years, which establishes its permanence and provides its vast opportunity for growth. Every interested viewer of the current scene, whether in the industry itself, the Executive Branch of Government, Congress, the universities, or the information media, is busy testifying to that phenomenon.

Every objective study on the potential applications of this industry's capabilities, and there have been many recently, has come up positive. What hasn't yet been done is specifically to relate the arts, practices and achievements of this avant-garde industry to the larger phenomenon that is taking place and specifically to relate that larger phenomenon in turn to the nation's and the world's future needs. For the larger phenomenon is nothing short of a new industrial revolution, and today's national and global needs are identical with those of the earlier industrial revolution: to both har-

ness and guide it for the future benefit of mankind.

The pace of technological advance is now so rapid that some would hold back through fear of its threat to human values. This fear will be justified in part if we don't master it. But the genius of democratic and free enterprise institutions has always been their ability to move with the dynamics of progress. The economic strength, political security and human welfare of a nation possessing but six percent of the world's population have always rested in major part on advanced technology. With burgeoning populations both at home and abroad advanced technology more than ever represents our principal hope for a prosperous and secure future.

The task is to recognize this new industrial revolution for what it is, guide its development and apply it to the fulfillment of our needs. In short, we should welcome a constant advance of technology for we need it badly in terms as fundamental as our national survival, but we also need a *relevant* advance of technology — one that is relevant to our human needs and our social institutions.

Both public and private leadership must divest itself of an all too prevalent disclaimer of responsibility and must commit itself to full participation in this enormous task. Neither must shy from such commitment, for nothing less will suffice. Our national success has been a history of industry not waiting for government and government not waiting for industry, but rather each forcing the pace on the other.

There are many obstacles, not the least of which is a chronic suspicion that has always existed in some degree between public and private leadership. Such suspicion emanates not from the individuals, for the same individual will shift his suspicion as he switches from one sector to the other, but rather from the perspective of the institutional responsibilities each represents. The public leader is frequently leery of the solution proposed by the private technologist for fear it won't make sense in human terms — and the converse is equally true.

The execution of this new industrial revolution will be much harder than evolving the patterns of industry-government relationships on the federal level. Each city, each state, each region will have to design and devise its own methods of coping institutionally with its own particular problems and with the application of technology to their solution in ways tailored to the

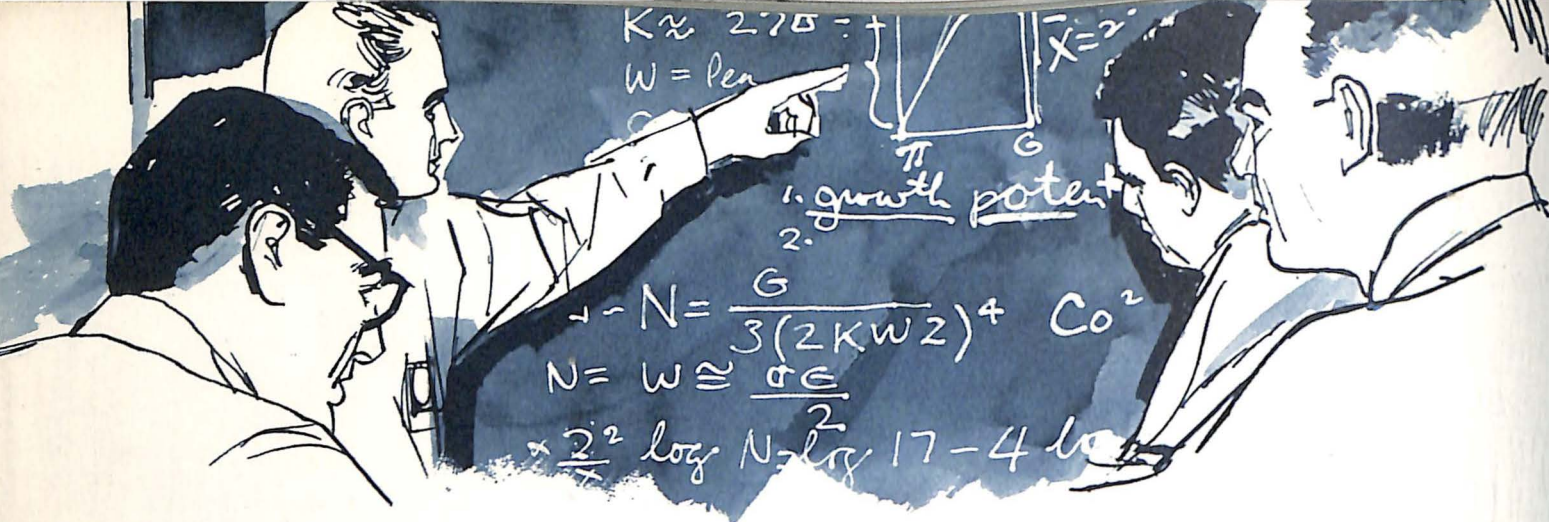

"... this industry is the cutting edge of the new industrial revolution."

human needs of its particular area.

But why should an industry such as the aerospace industry, fully engaged in supplying complex systems for the nation's defense, the nation's space effort and the nation's commercial air transport, care about getting involved in such a difficult and uncertain effort? There are many reasons. Let me suggest two:

First, whether we like it or not, this industry is the cutting edge of the new industrial revolution. Possessing more than a fifth of the nation's scientists and engineers, highly schooled in complex systems analysis and systems management, and experienced in dealing in public and quasi-public programs it represents, in simple terms, a model of what new American industry can and will be like. As the advance model it has both an opportunity and a responsibility.

Second, this industry has had to learn and learn well the disciplines and requirements of complex long lead time programs. For one simple example, the effort to land men on the moon, starting from scratch, required orderly programming of virtually every major technological, political, economic and human factor stretching over a dozen years. And complex long lead time programs are going to be necessary to solve most of our society's important problems.

Aerospace companies can and should do three things:

First, as a matter of high priority, in every way possible promote and foster open dialogue with government, particularly state and local governments, looking to ways and means of applying our capabilities to their problems. This effort is directed primarily at questions of future human environment. Industry has at least half of the responsibility to see that government and industry have the right organization to take full advantage of lead times and lead times which are creative and free. For even in closest harmony we cannot wholly order the future nor can we afford arbitrariness, nor can we simply turn over the world to engineers and accountants. Much experimentation will be needed in building viable public/private relationships at all levels at which they may be brought to bear on such problems.

Second, start now to plan our world trade position over the next five to ten years. Given the increasing competition for world markets, the essentiality of retain-

ing or improving our position in the future, and the increasingly complex interrelationship of technological, political and economic factors that will prevail, our lead time is already upon us. If we are going to continue to make the best, sell the best, do the best, five to ten years from now, we are going to have to apply all our lead time expertise right now.

Finally, accept as a private industrial responsibility the need to grasp boldly the nettle of technology. Start now to explore what it is we need to do to insure that we proceed to advance technology in accordance with unfolding social needs and thus make our accelerating technological advances as relevant as possible, not just to measure federal programs such as space and defense, but to making a better environment for our children.

Showing the way in modernizing American industry will help make a better America. Sustaining or improving our relative world trade position will help make a better America. But the biggest and hardest task before us — all of us — is to take the steps now to ward off the sinister and serious threats to our environment that we all are aware of. We can have a secure America and a prosperous America but if we are to have a truly better America for our children we've got to do something and do it now about the physical environment they'll be living in.

What we're really talking about are traffic jams and dirty air and dirty water and rotten housing and that's everybody's business. We who are caught up in the forefront of today's technology know that it isn't the technological difficulties that stand in the way of solutions to such problems. But possessing such knowledge in and of itself will not meet the need. As never before in its history it is time for industry to walk the extra mile. Since no one realizes as well as we do what is possible today and what will be possible tomorrow it is up to us to take the lead.

Everyone can agree that we are caught up by the forces of a new industrial revolution. But only if we in the industry most concerned insist that public and private leadership at all levels start working together and planning together now in full recognition of the phenomenon that is upon us and the common responsibility it entails, will any of us have a satisfactory answer to the clamoring question: "Revolution for what?"

AIA
MANUFACTURING
MEMBERS

Abex Corporation
Aerodex, Inc.
Aerojet-General Corporation
Aeronca Manufacturing Corporation
Aeronutronic Division, Philco Corporation
Aluminum Company of America
Avco Corporation
Beech Aircraft Corporation
Bell Aerospace Corporation
The Bendix Corporation
The Boeing Company
Cessna Aircraft Company
Chandler Evans, Inc.
Control Systems Division of
Colt Industries, Inc.
Continental Motors Corporation
Cook Electric Company
Curtiss-Wright Corporation
Douglas Aircraft Company, Inc.
Fairchild Hiller Corporation
The Garrett Corporation
General Dynamics Corporation
General Electric Company
Defense Electronics Division
Flight Propulsion Division
Missile & Space Division
Defense Programs Division
General Laboratory Associates, Inc.
General Motors Corporation
Allison Division
General Precision, Inc.
The B. F. Goodrich Company
Goodyear Aerospace Corporation
Grumman Aircraft Engineering Corp.
Gyrodyne Company of America, Inc.
Harvey Aluminum, Inc.
Hercules Incorporated
Honeywell Inc.
Hughes Aircraft Company
IBM Corporation
Federal Systems Division
International Telephone & Telegraph Corp.
ITT Federal Laboratories
ITT Gilfillan, Inc.
Kaiser Aerospace & Electronics Corporation
Kaman Aircraft Corporation
Kollsman Instrument Corporation
Lear Jet Corporation
Lear Siegler, Inc.
Ling-Temco-Vought, Inc.
Lockheed Aircraft Corporation
The Marquardt Corporation
Martin Company
McDonnell Aircraft Corporation
Menasco Manufacturing Company
North American Aviation, Inc.
Northrop Corporation
Pacific Airmotive Corporation
Piper Aircraft Corporation
PneumoDynamics Corporation
Radio Corporation of America
Defense Electronic Products
Rockwell-Standard Corp.
Aircraft Divisions
Rohr Corporation
Ryan Aeronautical Company
Solar, Division of International
Harvester Co.
Sperry Rand Corporation
Sperry Gyroscope Company
Sperry Phoenix Company
Vickers, Inc.
Sundstrand Aviation, Division of
Sundstrand Corporation
Thiokol Chemical Corporation
TRW Inc.
United Aircraft Corporation
Westinghouse Electric Corporation
Aerospace Electrical Division
Aerospace Division
Astronuclear Laboratory
Marine Division

AEROSPACE INDUSTRIES ASSOCIATION

1725 De Sales St., N.W., Washington, D. C. 20036

Teamwork between the military services and the aerospace industry is providing a swift response for equipment requirements generated by Vietnam operations. (See *Vietnam and the Aerospace Industry — Challenge and Response*, page 10).



aerospace

OFFICIAL PUBLICATION OF THE AEROSPACE INDUSTRIES ASSOCIATION • OCTOBER 1966

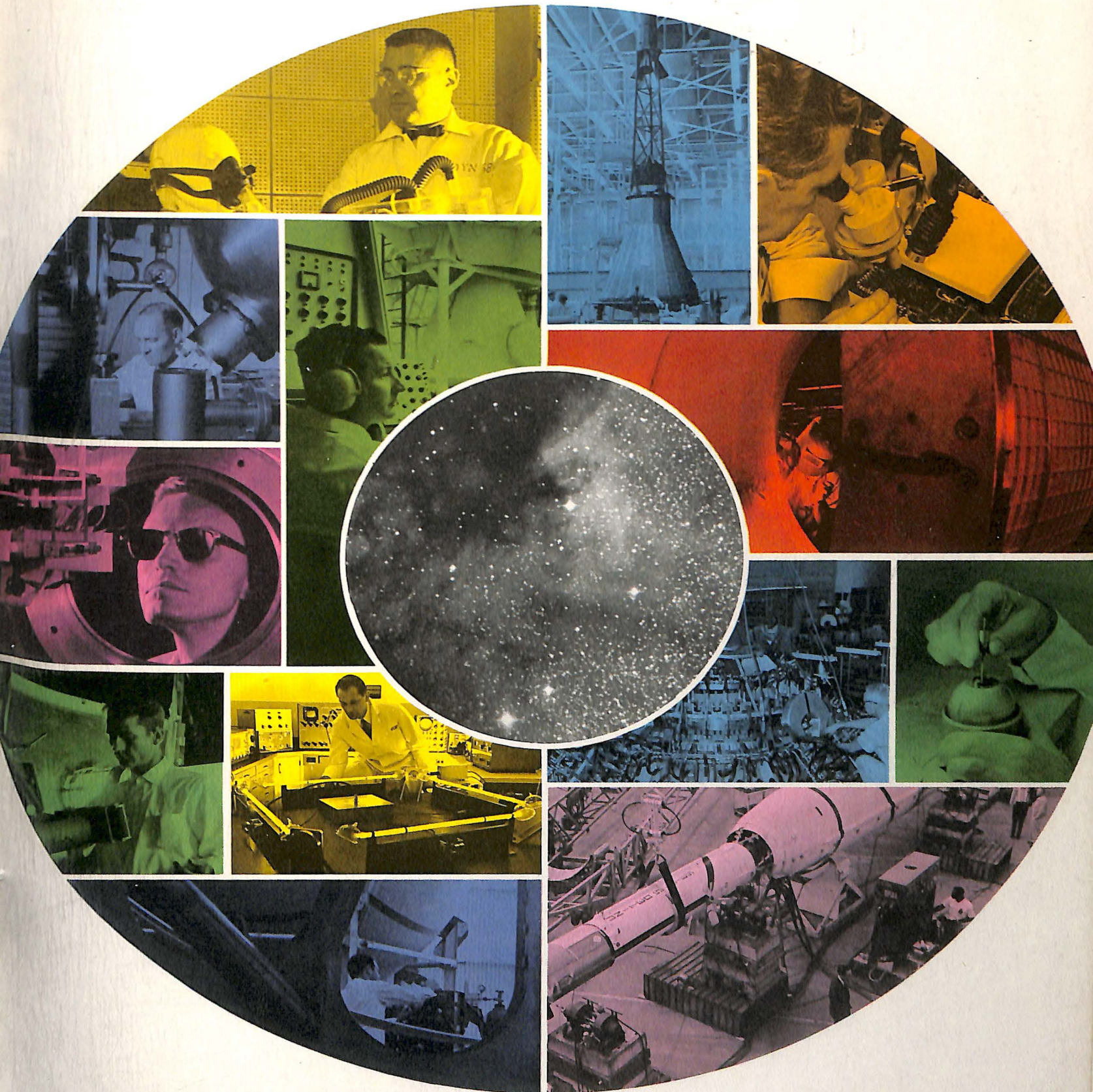

- SPACE AND INDUSTRY GOALS AND RESULTS
- AEROSPACE EMPLOYMENT

AEROSPACE ECONOMIC INDICATORS

CURRENT

Total Aerospace Sales

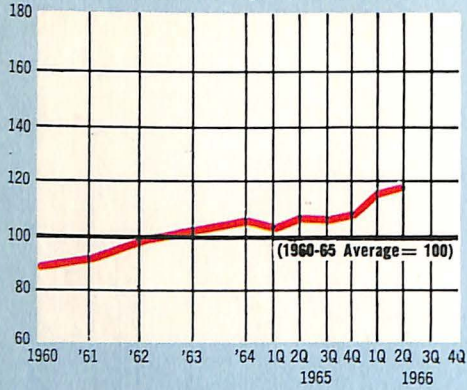

Value of Civil Aircraft Shipments

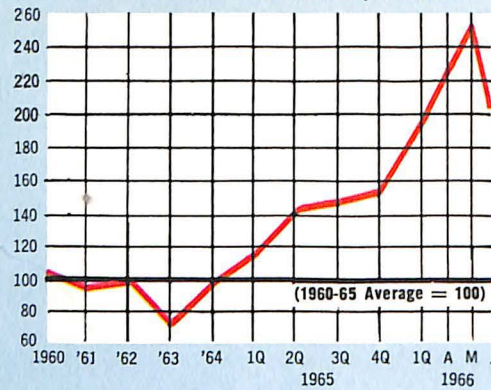

OUTLOOK

New Orders — Monthly Average

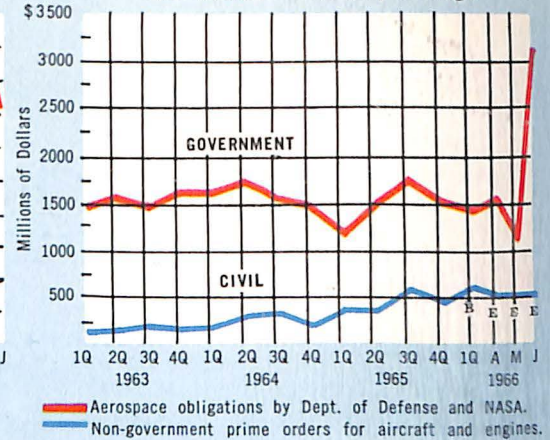

ITEM	UNIT	PERIOD	1960-65 AVERAGE *	LATEST PERIOD SHOWN	SAME PERIOD YEAR AGO	PRECEDING PERIOD †	LATEST PERIOD
AEROSPACE SALES: Total	Billion \$	Annual Rate	19.4	Quarter Ending June 30	20.8	22.4 ^E	22.8 ^E
	Billion \$	Quarterly	4.8	1966	5.4	5.6	5.8
DEPARTMENT OF DEFENSE							
Aerospace obligations: Total	Million \$	Monthly	1,151	June 1966	1,440	785	2,770 ^E
Aircraft	Million \$	Monthly	601	June 1966	862	584	2,039
Missiles & Space	Million \$	Monthly	550	June 1966	578	201	731
Aerospace expenditures: Total	Million \$	Monthly	1,067	June 1966	785	759	1,366 ^E
Aircraft	Million \$	Monthly	561	June 1966	520	528	853
Missiles & Space	Million \$	Monthly	506	June 1966	265	231	513
NASA RESEARCH AND DEVELOPMENT							
Obligations	Million \$	Monthly	215	June 1966	404	296	385
Expenditures	Million \$	Monthly	180	June 1966	379	485	439
UTILITY AIRCRAFT SALES							
Units	Number	Monthly	692	Aug. 1966	1,040	1,093	1,265
Value	Million \$	Monthly	15	Aug. 1966	26	28	36
BACKLOG (60 Aerospace Mfrs.): Total	Billion \$	Quarterly	15.3 #	Quarter Ending	15.9	20.4	22.4 ^E
U.S. Government	Billion \$	Quarterly	11.6	March 31	11.6	13.7	14.4
Nongovernment	Billion \$	Quarterly	3.7	1966	4.3	6.7	8.0
EXPORTS							
Total (Including military)	Million \$	Monthly	110	July 1966	93	137	109
New Commercial Transports	Million \$	Monthly	24	July 1966	14	42	18
New Utility Aircraft	Million \$	Monthly	2	July 1966	7	9	9
PROFITS				Quarter Ending			
Aerospace — Based on Sales	Percent	Quarterly	2.3	June 30	3.1	3.1	3.2
All Manufacturing — Based on Sales	Percent	Quarterly	4.8	1966	5.8	5.6	5.9
EMPLOYMENT: Total	Thousands	Monthly	1,132	July 1966	1,153	1,277 ^E	1,306 ^E
Aircraft	Thousands	Monthly	499	July 1966	457	540	565
Missiles & Space	Thousands	Monthly	496	July 1966	526	566	569
AVERAGE HOURLY EARNINGS, PRODUCTION WORKERS	Dollars	Monthly	2.92	July 1966	3.16	3.37	3.38 ^E

^E Estimate

* 1960-65 average is computed by dividing total year data by 12 or 4 to yield monthly or quarterly averages.

† Preceding period refers to month or quarter preceding latest period shown.

Averages for 1961-65.

EXPANDING ANSWERS TO EXPANDING PROBLEMS

BY KARL G. HARR, JR.

President, Aerospace Industries Association
(From remarks made before banking and investment
executives, Union League Club, Chicago, Ill.)

... with our growing population and geometrically expanding needs, more and more of our answers are going to have to come from applying advanced technology to complex problems. The dialogue that suggests that technological advance constitutes a threat to social advance is hopelessly myopic. It could be such a threat, of course, if we failed utterly to adjust to or apply it, and just let it run rampant. But for a nation which has and demands the world's highest standard of living, which has but 6 percent of the world's population, which has attained and maintained both its security and prosperity in large part on technological preeminence, and which is caught up in both a spiralling technological advance and spiralling social environment problems, the only path to future well-being lies in controlling and exploiting such technology to our will and benefit. . . .

Whether it be in doing analysis for the Governor of California on subjects so alien to aerospace as crime control or information collection; whether it be in sending teams of analysts to underdeveloped countries to draw up plans for total transportation systems; whether it be in devising vertical lift and V/STOL answers to interurban transport here at home; whether it be in bidding on high-speed rail systems or radically new ship designs; whether it be in investing heavily in smog and water pollution control programs or whatever, an awareness is already all pervasive within the industry. . . .

It has been responsibly estimated that between now and the end of the century the problems of providing clean air and clean water alone will provide a market of at least \$275 billion. There are probably four or five other non-defense and non-space national human environmental needs, such as solving urban congestion and inadequate housing, coping with both urban and interurban transportation congestion and accelerating food production and distribution.

Who is going to do such jobs, government or private industry?

It wasn't too long ago that you would have had to say these jobs will be primarily done by the government. If you wanted the "desert to bloom" no one would have thought of any other way than the establishment of a government agency to accomplish it. And this was not only because public matters were deemed to require public programs and public administration, it was also because no one on the private industry side would even begin to regard the fulfillment of such a need as a private business opportunity or even begin to think it had the total capability required. This is what has so radically changed. I submit that if you want the "desert to bloom" you will contract the job out and you will find a highly competitive response from private industry, particularly from the aerospace industry. . . .

However, the aerospace industry is not transferring from the business of producing aerospace systems to the business of producing clean water.

If I were to try to put my finger on the one most serious deficiency in the ingredients essential to achievement it would be to question whether the private investment community is fully up to speed in appreciation of where we are going. I suggest that as long as a company's future worth is judged wholly in terms of whether or not it got this or that federal contract, or as long as the industry's future health is judged wholly on the basis of defense or space appropriations, the trees are obscuring the forest. I suggest the only sound basis for an evaluation of the future from an investment point of view involves these considerations:

Are there going to be large projects, public, private and mixed, to be performed over the next two or three decades which require the large scale application of advanced technology?

Are these jobs going to be done primarily by private industry?

If so, which industry is going to be primarily involved?

The answers are rather easy.



aerospace

Official Publication of the
Aerospace Industries Association of America, Inc.

PRESIDENT • Karl G. Harr, Jr.

PUBLISHER • Glen Bayless

VOL. 4, NO. 8

OCTOBER 1966

EDITOR • Gerald J. McAllister

ASSOCIATE EDITORS • Richard W. Balentine

• William S. Evans

• John J. Lee

ECONOMIST • Gerson N. Chanowitz

ART DIRECTOR • James J. Fisher

CONTENTS

2 SPACE AND INDUSTRY — GOALS AND RESULTS

8 AEROSPACE NOTES

10 AEROSPACE EMPLOYMENT

14 NATIONAL AEROSPACE STANDARDS — KEY TO EXCELLENCE

16 SST — INTERACTION OF TECHNOLOGY AND SOCIETY

By Senator A. S. Mike Monroney

The purpose of AEROSPACE is to:

Foster understanding of the aerospace industry's role in insuring our national security through design, development and production of advanced weapon systems;

Foster understanding of the aerospace industry's responsibilities in the space exploration program;

Foster understanding of civil aviation as a prime factor in domestic and international travel and trade;

Foster understanding of the aerospace industry's capabilities to apply its techniques of systems analysis and management to solve local and national problems in social and economic fields.

AEROSPACE is published monthly by the Aerospace Industries Association of America, Inc., the national trade association of the designers, developers and manufacturers of aircraft, missiles, spacecraft, their propulsion, navigation and guidance systems and other aeronautical systems and their components.

Publication Office: 1725 De Sales Street, N.W., Washington, D. C. 20036

Western Office: McCulloch Building, 6151 West Century Blvd., Los Angeles, Calif. 90045

All material may be reproduced with
or without credit.

SPACE & GOALS

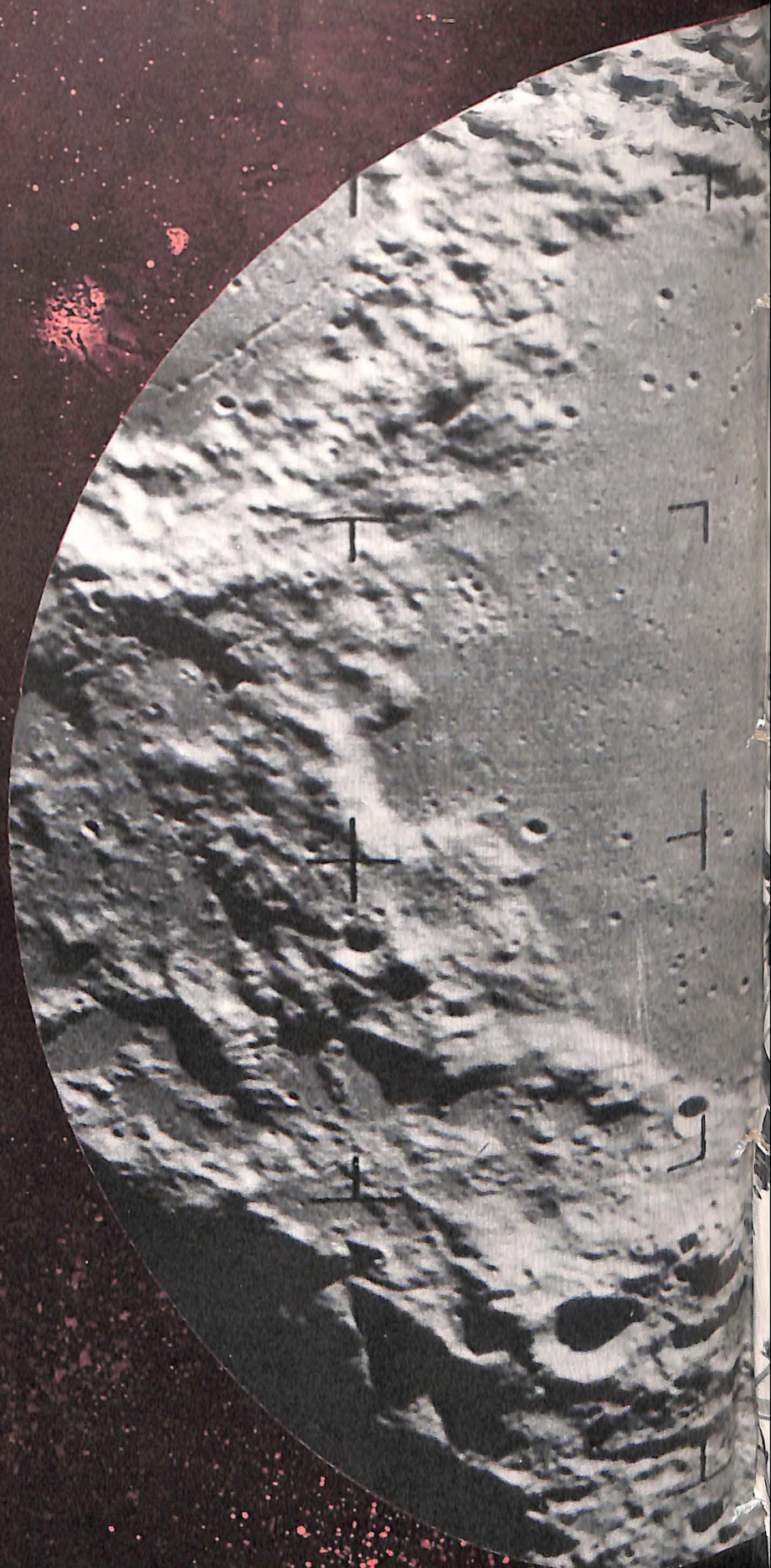

INDUSTRY RESULTS

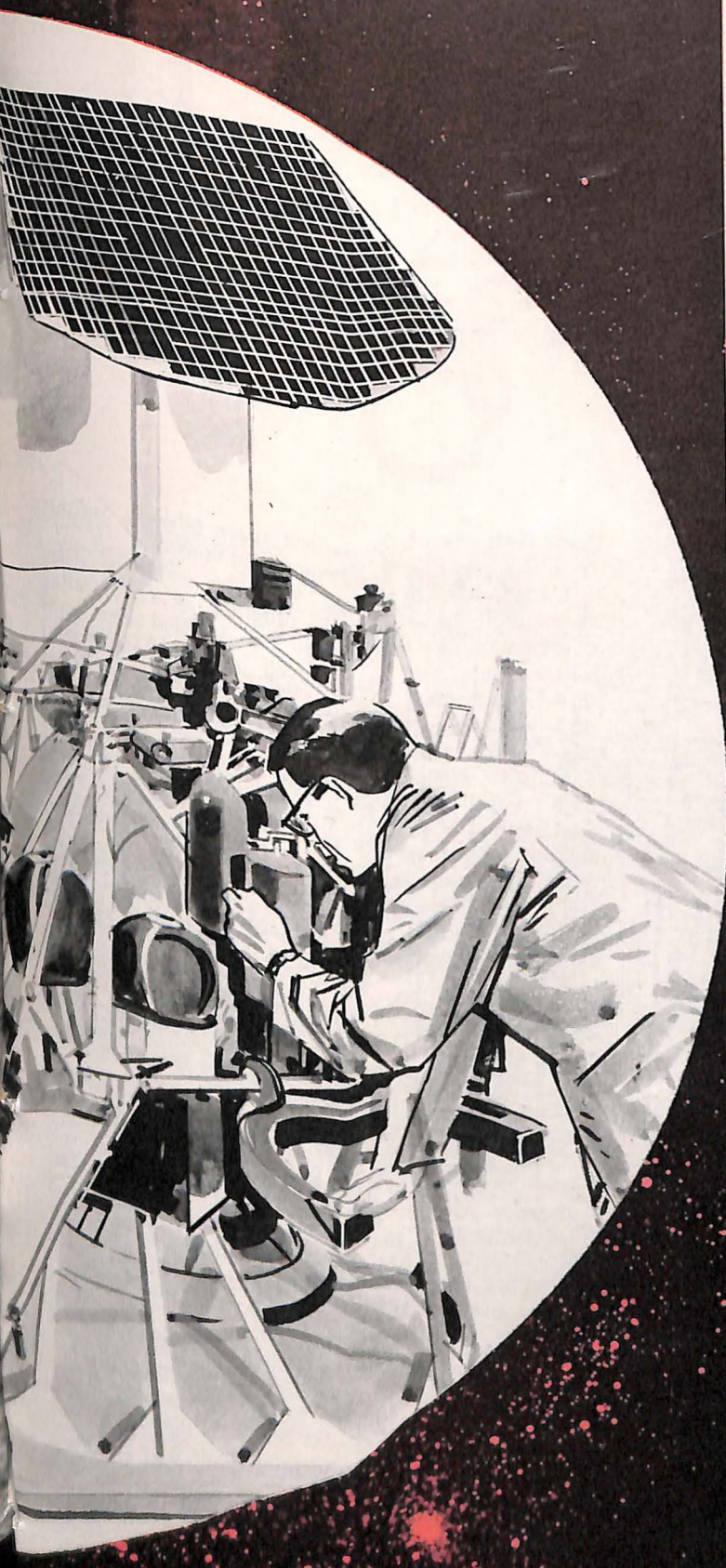

The National Aeronautics and Space Administration, since its establishment eight years ago this month, has harnessed the infinitely diverse skills of the nation for the most meaningful technological goal ever established: space exploration.

Congress defined NASA's mission in October 1958: Manage the scientific exploration of space, send men there to reconnoiter, use space technology to promote human welfare. But it was the late President Kennedy who, in 1961, gave NASA its most awesome command: Land men on the moon this decade.

Any detailed account of the aerospace industry's role in these assignments would be voluminous. Basically, the industry provided the equipment — the most complex and sophisticated ever devised by man — and the techniques that have taken man and his machines far beyond his rind of atmosphere.

In the first few years after the establishment of NASA, the aerospace industry moved into high gear to meet the demands of far-reaching programs for space exploration.

For example:

Philco's Aeronutronic Division developed, starting in 1960, a lunar landing capsule and a complete payload delivery system for the Ranger vehicle which impacted on the moon two years later.

Marquardt Corporation's early efforts in small control rockets led to its selection in 1960 to build the attitude control rockets for the Apollo service module and the lunar module which is scheduled to land men on the moon at the end of this decade.

International Business Machine's newly-created Federal Systems Division provided computers for Project

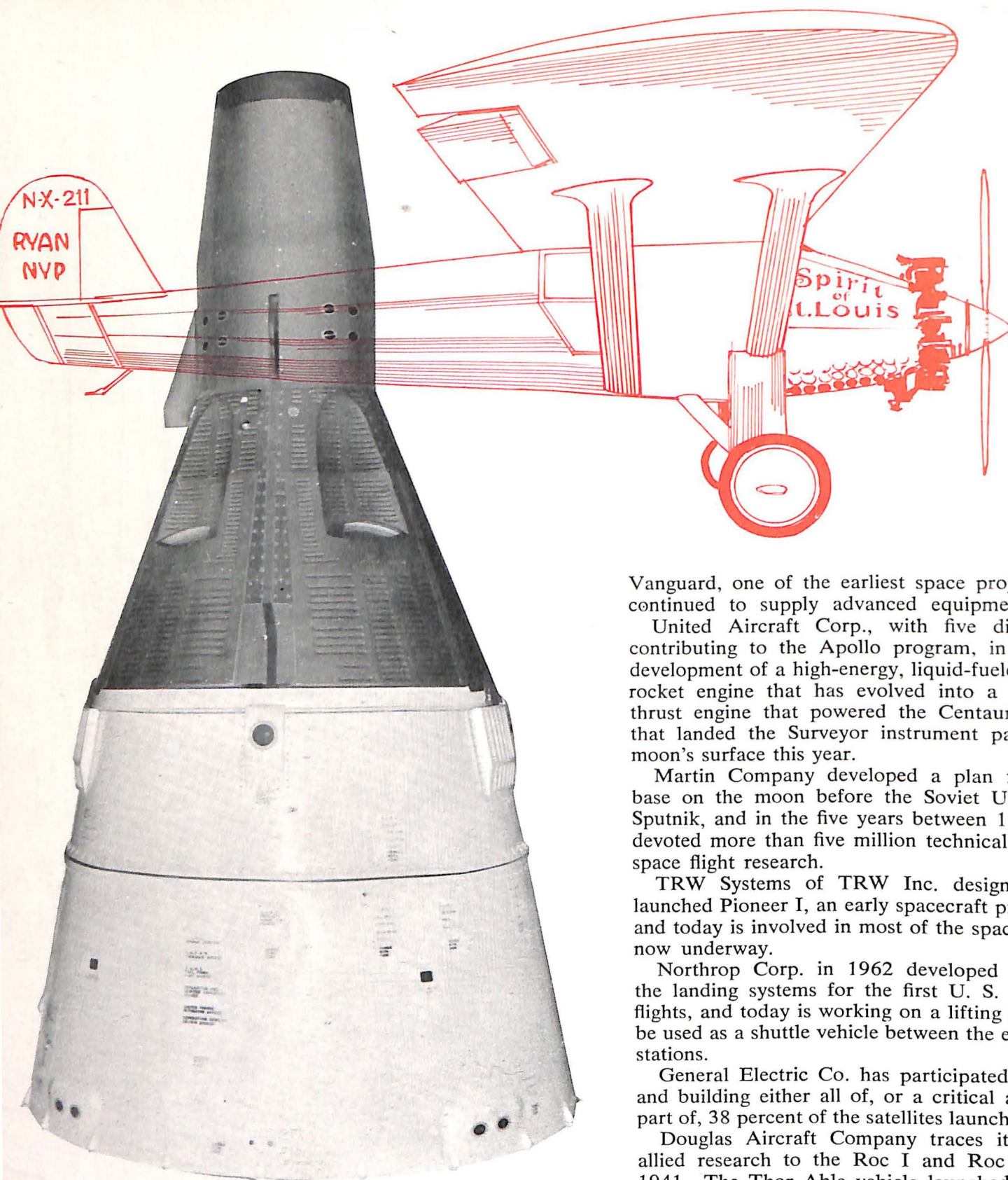

The competence of the aerospace industry in space projects is rooted in its vast background of aeronautical experience. *The Spirit of St. Louis* and a Gemini capsule are logically exhibited together in the Smithsonian Institution. To the layman, a basic flight instrument, the altimeter, appears to be same in both the airplane and the space capsule.

Vanguard, one of the earliest space projects, and has continued to supply advanced equipment.

United Aircraft Corp., with five divisions today contributing to the Apollo program, in 1958 started development of a high-energy, liquid-fueled upper stage rocket engine that has evolved into a 15,000-pound thrust engine that powered the Centaur in the flight that landed the Surveyor instrument package on the moon's surface this year.

Martin Company developed a plan for a manned base on the moon before the Soviet Union launched Sputnik, and in the five years between 1959 and 1965 devoted more than five million technical man-hours to space flight research.

TRW Systems of TRW Inc. designed, built and launched Pioneer I, an early spacecraft project in 1959, and today is involved in most of the spacecraft projects now underway.

Northrop Corp. in 1962 developed and produced the landing systems for the first U. S. manned space flights, and today is working on a lifting body that may be used as a shuttle vehicle between the earth and space stations.

General Electric Co. has participated in developing and building either all of, or a critical and substantial part of, 38 percent of the satellites launched by the U. S.

Douglas Aircraft Company traces its early space-related research to the Roc I and Roc II missiles in 1941. The Thor Able vehicle launched the Pioneer I deep space probe in 1958, and the company today makes a stage for the Saturn V booster for Apollo.

Thiokol Chemical Corp. has long been involved in rocket engine tasks, built the solid retro rockets for the Discoverer XIII, the first satellite recovered from orbit.

McDonnell Co. built the first U. S. manned spacecraft, Mercury, and followed this with the highly successful manned spacecraft Gemini which had a lengthy series of successes.

Aerogel-General Corp. started work in 1961 on the

Explorer I (left), the first U. S. satellite, was launched January 31, 1958 by a Jupiter-C booster. The Jupiter produced 83,000 pounds of thrust and the Explorer satellite weighed 18 pounds. The Saturn V booster produces 7,500,000 pounds of thrust, can put 235,000 pounds into orbit.

NERVA nuclear-powered rocket and has been extensively involved in virtually every major propulsion program. Largely space-oriented, about 75 percent of all Aerojet sales — and employees — are in space projects.

Lear Siegler, Inc. became involved in space programs when the firm provided hydraulic power packs for the Discoverer, and has contributed to most NASA programs since 1959.

Rohr Corporation formed a Space Products Division in 1963, today makes components for most of the larger booster systems.

Bell Aerosystems started work in 1959 on the reaction controls for Mercury and has developed such exotic equipment as a plasma-jet generator for testing materials used in space vehicles.

North American Aviation was challenged by NASA to build rocket engines for several space boosters, electronic systems and, of course, Apollo, the project to put man on the moon.

Hughes Aircraft has provided key components for the Nimbus weather satellite, and has produced the Syncom series of communications satellites.

Sperry Rand Corp. in 1959 delivered the inertial platforms for the Jupiter booster which launched the Explorer series, and today supplies the accelerometers for the Apollo program.

When NASA was established, aerospace personnel engaged in space work was scarcely measurable. By the end of this year, the Aerospace Industries Association estimates that 276,000 persons in industry, a large proportion of them scientists and engineers, will be working on space projects.

The fact that the aerospace industry successfully responded to the challenge of space exploration is technical history.

Most of the early NASA procurement contracts were cost-plus-fixed-fee type. About 90 percent of all contracts in 1961 valued at more than \$25,000 were

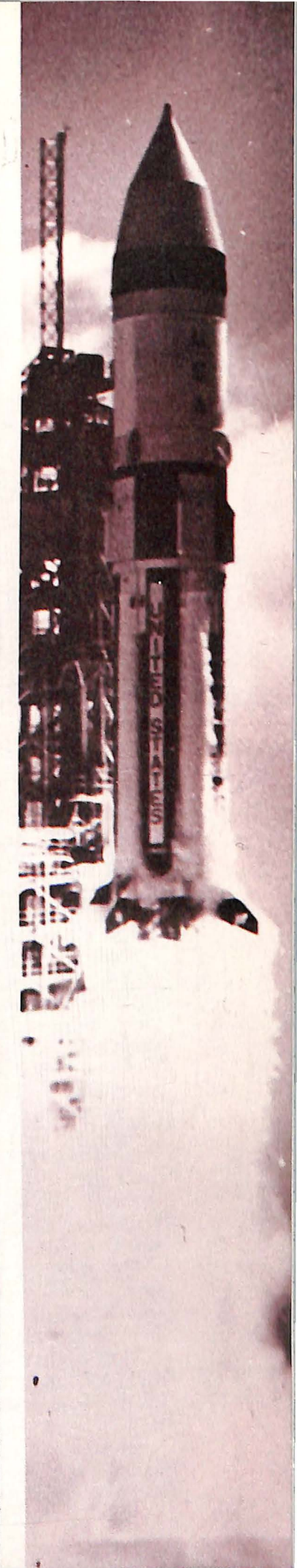
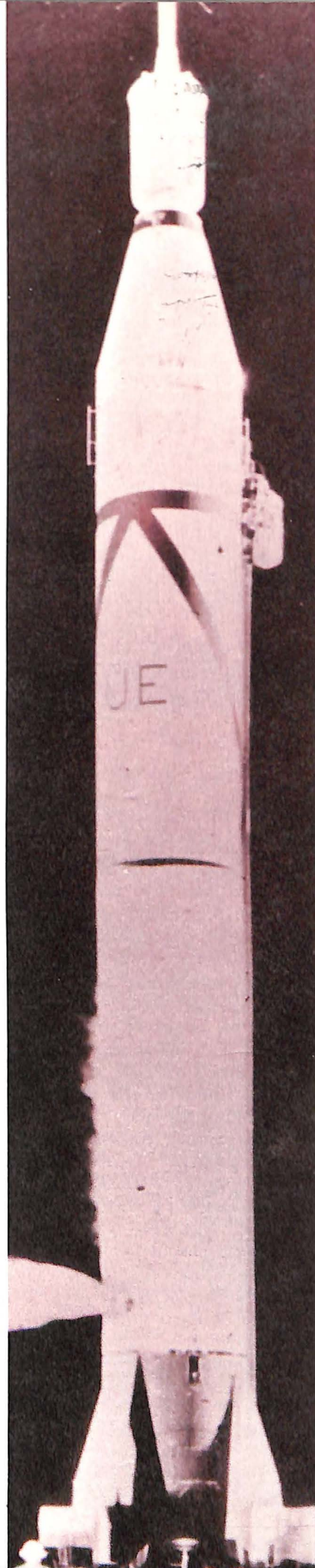

"The space sciences are at the heart of our program of space exploration; it is the search for new knowledge and its application to our understanding of the fundamentals of the universe that energizes our technology development and systems to put this technology to work in practical applications." —James E. Webb, Administrator, National Aeronautics and Space Administration

Examples of some of the scientific and applied satellites are shown at right. Their accomplishments have been remarkable. The Mariner travelled 326 million miles to send back the first measurements of the magnetic field and atmosphere of the planet Mars. The photographs of the moon made by Ranger spacecraft show that the design of the Lunar Module is suited to the topography of a large part of the moon's surface. The contributions of applied satellites such as the Tiros (weather) and Early Bird (communications) are well known.

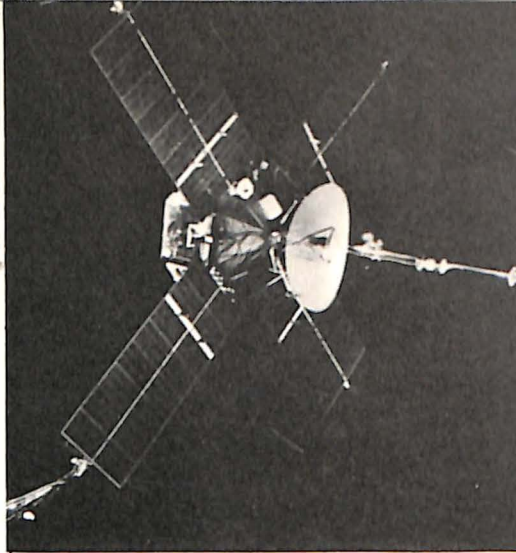

MARINER

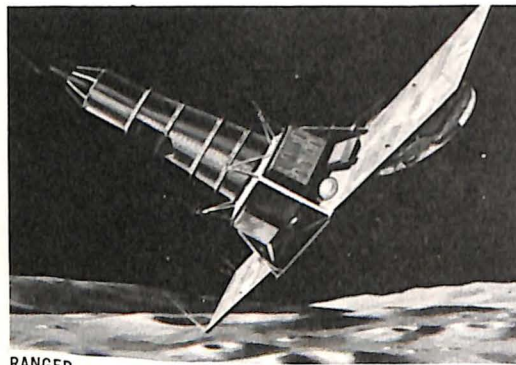

RANGER

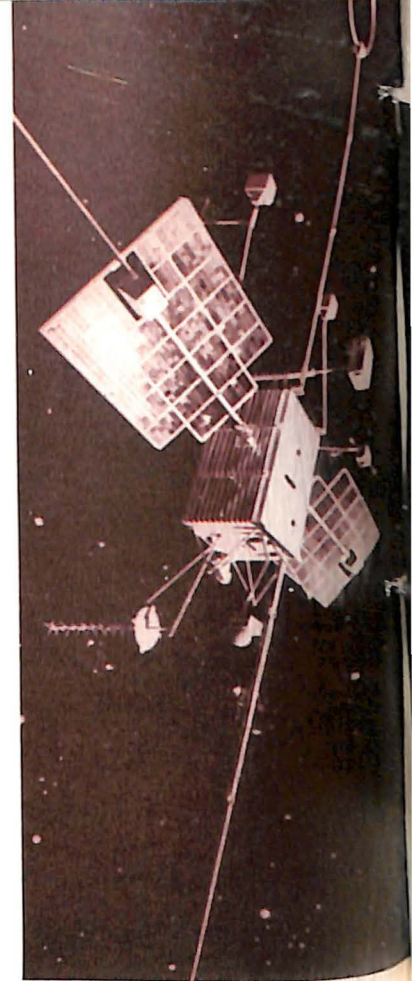

ORBITING GEOPHYSICAL OBSERVATORY

placed in just 10 states.

Today space business has percolated into every niche of the nation. In Fiscal Year 1961, NASA initiated 85,000 procurement actions with the aerospace industry; in just the first half of Fiscal Year 1966, the agency placed 98,000 orders with industry.

Were the companies confident they could meet NASA's engineering challenge—the challenge of building a valve, a switch or a booster that refused to fail under unknown stresses? As an expression of their confidence, aerospace companies substituted cash for promises. They sat down with NASA contractors and negotiated, or substituted, scores of incentive contracts for the traditional cost-plus-fixed-fee type.

Thus, in 1961, NASA incentive contracts totaled about \$100,000. By the middle of Fiscal 1966, the space agency was administering \$2.2 billion worth of incentive awards, or three times the total being administered one year earlier. And the trend toward incentive contracting is still gaining momentum.

The aerospace companies demonstrated that they were not overwhelmed by the challenge of protecting men in the space vacuum.

Tangible evidence?

They pulled top scientists and engineers away from bread-and-butter projects — airframe design, military missiles, industrial hardware — and assigned them tasks defined by the space agency. If their most precious corporate asset was technical creativity, they willingly invested that asset at a time when space exploration might, or might not, mature into big business.

It is interesting to compare NASA's mission with the mission assigned Project Manhattan scientists during World War II. Manhattan scientists who built the first atomic bomb could turn only to each other for technical assistance, for no great reservoir of nuclear knowledge existed in either government or industry. But NASA, assigned more ambitious goals, could turn to a spectrum of companies with established competence in sending men and machinery into hostile, sometimes airless environments.

A visit to the Smithsonian Institution in Washington drives home how that competence evolved.

Cables keep the *Spirit of St. Louis* permanently airborne under the broad Smithsonian roof. In 1927, this single-engine monoplane carried Col. Charles Lindbergh 3,610 miles across the North Atlantic to Paris. Just below its Smithsonian perch sits the spacecraft Gemini 4. In 1965, this funnel-shaped space machine carried astronauts Jim McDivitt and Ed White through 62 earth orbits and offered White safe haven after he returned from a 21-minute space walk.

The *Spirit of St. Louis* was built by Ryan Airlines, the predecessor to the Ryan Aeronautical Company. Today Ryan is building the vital landing radar system for the Apollo lunar module, and the landing field on the moon.

Among the maze of instruments crammed into the metal cocoon of Gemini is an altimeter, for use on ascent and re-entry. To a layman, Gemini's "miniaturized" black-backed altimeter with its delicate, luminescent hands is indistinguishable from the one Col.

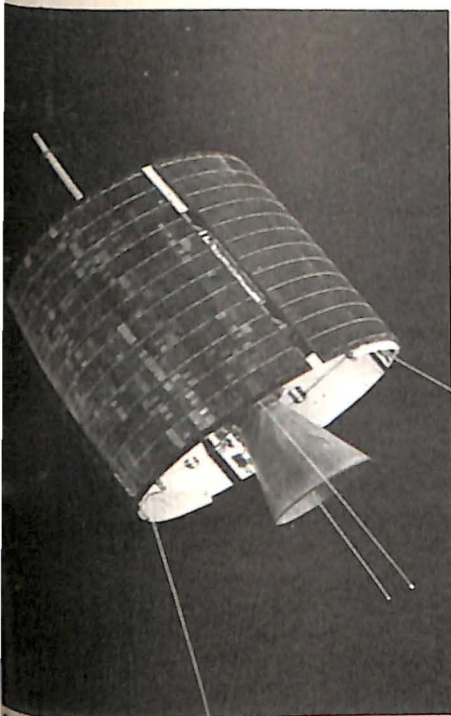

EARLY BIRD

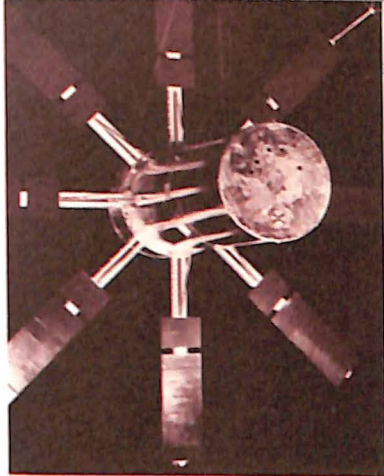

ORBITING SOLAR OBSERVATORY

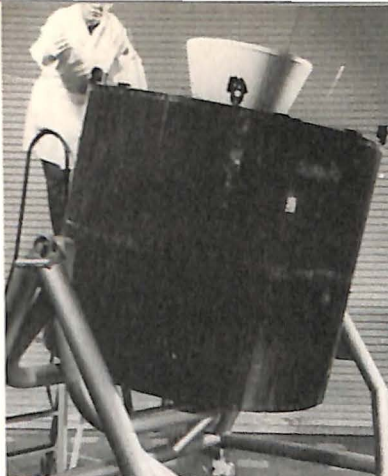

APPLICATIONS TECHNOLOGY SATELLITE

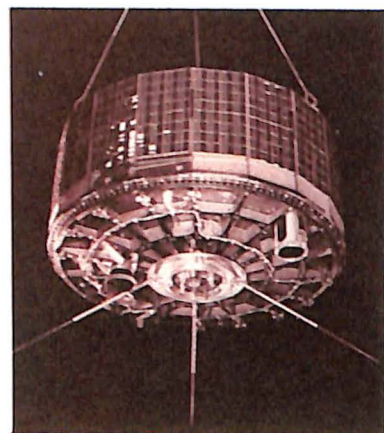

TIROS

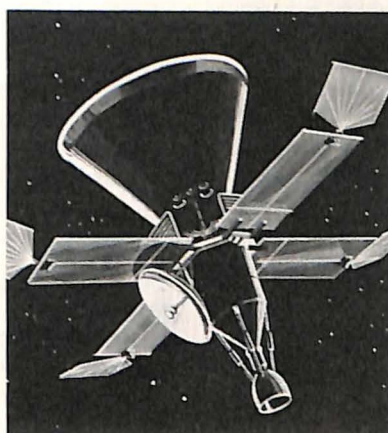

VOYAGER

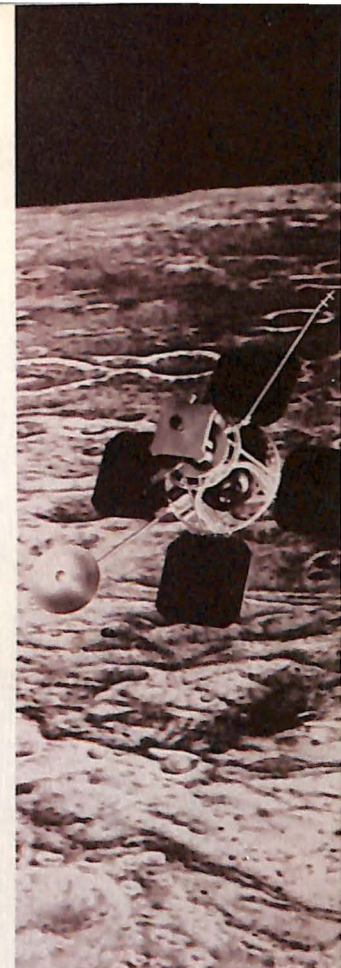

LUNAR ORBITER

Lindbergh used during his 32-hour flight.

In sum, the aerospace industry began building a space technology 50 years ago. That technology was utilized by the military when rockets became meaningful weapons during World War II. NASA honed it finer as men prepared to ride the rockets. The effects on some of the old-line airframe companies were notable.

Consider the case of Grumman Aircraft and Engineering Corp.

Grumman broke into the aviation business in 1931, the year the U. S. Navy awarded it a contract to develop the XFF-1 prototype fleet defense fighter. For the next 30 years, Grumman built thousands of aircraft. But as of 1959, Grumman sales in the space business totaled zero.

Change came suddenly in 1960: Grumman was selected from among 12 prime contractors to build the Orbiting Astronomical Observatory for NASA. In 1962, it won the \$350 million contract to develop Apollo's lunar module, the first manned spacecraft designed to operate solely in outer space. And for the first time in Grumman's history, the largest single contract in the house was for a spacecraft instead of an airplane.

By 1965, five years after Grumman entered the space business, a significant change had occurred. Space sales were running 50 percent of Grumman's total gross. And 45 percent of all Grumman scientists and engineers were working on space programs.

The experience of Grumman is duplicated in varying degrees by every company in the aircraft business.

The technological competence of industry is abundantly evident.

McDonnell's Gemini spacecraft, their missions aloft complete, splash down regularly beside the waiting carriers. Radio Corporation of America builds nine TIROS satellites, and every day for four consecutive years they beam back startlingly clear photographs of the clouds above us. The first Hughes Surveyor eases onto the moon to eavesdrop, and no sooner do its batteries spend themselves than Boeing's Lunar Orbiter flashes overhead to continue the reconnaissance.

The space walk, the pinpoint splashdown and the lunar closeup are just the visible successes. The significance of the successes strikes deeper.

If industry can construct powerful, complicated boosters proven 100 percent safe to ride, then certainly it can apply quality control fabrication and assembly techniques thus learned to the construction of any creature comfort: cars, TV sets or marine motors.

If industry can insulate the astronauts from the searing 20,000-degree heat of re-entry, then surely it can protect the passengers of a supersonic transport cruising with a skin temperature of 450 degrees.

If industry can rid the Gemini cabin of ozone, CO₂ and other noxious gases, then surely it can guarantee that supersonic passengers will breathe clean air.

If industry can produce systems that require coordination of thousands of companies, then what could these skills do with the problems of polluted air and water and urban slums?

The answer — in the positive — is present in the aerospace industry's performance in space exploration.

AEROSPACE NOTES



Convair Simulates Space Maintenance with Scooter

Space scientists at Convair's Kearny Mesa plant have developed a three-degrees of freedom frictionless scooter to investigate restraint and tethering systems, to perform simulated space maintenance tasks and for maneuvering unit familiarization and training.

Built mainly from spare parts and scrap materials, the scooter, dubbed "Junior," uses air bearings and floats over a surface on an air cushion.

Convair scientists have used a space gun provided by another manufacturer while operating the scooter in preparation for developing its own maneuvering space gun and possibly a backpack maneuvering unit.

Honeywell Radar Altimeter Selected for Helicopters

U.S. Navy has selected a high accuracy radar altimeter built by Honeywell Inc. as the standard fleet altimeter and has begun equipping combat helicopters as well as those of the Marine Corps with the instrument.

In addition to assault landing missions, the Honeywell altimeter is qualified for use in anti-submarine warfare, utility-observation, tactical support and other low-level missions requiring precision day or night indication of absolute terrain or sea levels.

The altimeter tracks the leading edge

of the reflected microwave pulse, providing the pilot with a continuous indication of elevation to within 1½ feet plus 1 percent of actual altitude under standard conditions. Readings are provided to touchdown from altitudes of 5,000 or 1,000 feet, depending on the model.

The pulsed system has rapid search and acquisition characteristics, is immune to Doppler frequency-shift effects, eliminates signal averaging errors found in conventional systems, and has little susceptibility to signal-jamming countermeasures.

Goodyear Lightweight Armor Protects Helicopter Crews

Goodyear Aerospace Corp. has developed a lightweight, bullet-proof armor from ceramic material and fiberglass for helicopter crewmen operating in Vietnam.

Crewmen were very vulnerable to ground fire as they maneuvered their aircraft during assault and rescue missions. Conventional flak jackets were of little help in fending off high-velocity bullets.

The new armor is lighter than steel, yet more effective in bullet-stopping power. The torso armor, which is made in small, medium and large, is put into a khaki vest which slips over the head of the crewman. Leg and thigh armor is outfitted with straps.



RCA Develops Molybdenum Heat Transfer Device

Efficient transfer of thermal energy from a heat source to a thermionic device for direct conversion into electricity is possible with the development by Radio Corporation of America of a "heat pipe" built of molybdenum.

Molten lithium metal is vaporized at one end of the molybdenum tube, enabling it to absorb great quantities of thermal energy from the heat source such as a nuclear reactor, a radioisotope source, or a fossil-fuel burner. The vapor from the metal is transferred by thermodynamic action to the opposite end of the pipe where it condenses and releases this energy with a negligible temperature drop.

The heat pipe is expected to operate effectively in outer space since it has no moving parts and is unaffected by gravity. It was developed for the U.S. Air Force by RCA.

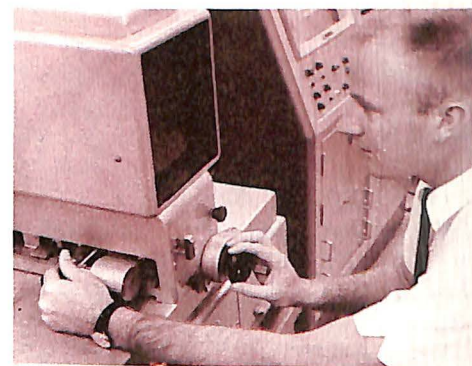

Spectrograph Speeds Metal Analysis at NAA Laboratory

Quantitative analysis of metal can be performed ten times faster than could be obtained by conventional wet chemical analysis in the Spectrograph Laboratory of Materials and Processes at North American Aviation's Rocketdyne division.

Using X-ray and emission spectrography, laboratory engineers can perform qualitative as well as quantitative analysis of metal for engineering and quality control. Lab personnel also identify residues and contaminants that are found during materials investigations and failure analysis.

The accompanying photograph shows an employee identifying elements present in an unknown sample of metal using a comparator-densitometer.

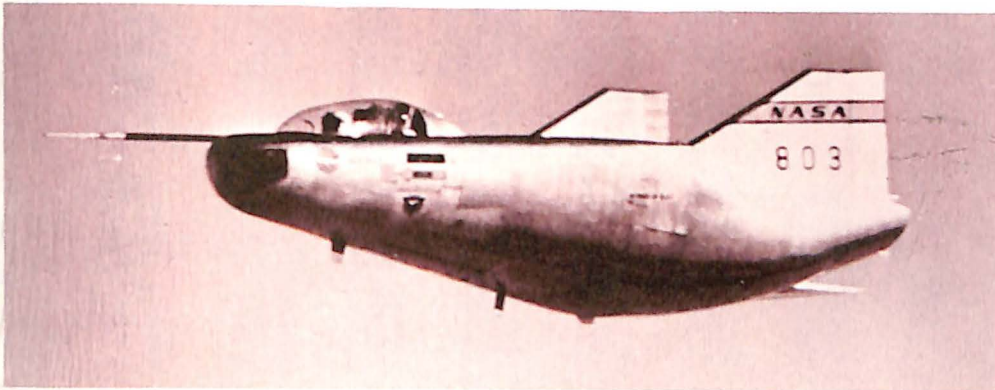

Northrop Lifting Body Makes First Free Flights

The unique M2-F2 lifting body, built by Northrop Corporation for the National Aeronautics and Space Administration, has successfully completed free flights.

The vehicle was dropped from the wing of a Boeing B-52 bomber and then glided to a landing on Rogers Dry Lake Bed at Edwards, Calif., with Milton O. Thompson, chief NASA lifting body pilot, at the controls.

The M2-F2 is a design approach for future interplanetary and space station shuttle craft.

Boeing Scientists Seek Answers to Vibrations

Dual-frequency vibrations experienced by operators of aerospace or ground vehicles are being investigated by human factors scientists and The Boeing Company.

Identifying and evaluating the combined effects of vibrations from several sources will have an important bearing on human perception, fatigue, sensitivity and performance.

Human subjects are placed in a special rigid seat and multiple vibrations are applied. A doctor is present at all tests and closely watches the subjects for any signs of distress or extreme changes in their performance.

The subject is held in a pilot's seat by a special lap belt with a grip that cannot be loosened by vibration. The seat is mounted atop a platform and a hydraulic cylinder which supplies the up-and-down motion. A simulated cockpit eliminates outside distraction.

The vibrations, of different frequencies ranging from one to 27 cycles a second, are controlled from a lab beneath the control booth.

Martin Forms Booster Tank with Explosives

Two large end sections for space booster tanks have been formed with single charges of high explosives by the Martin Company.

This is the first time parts of such size and depth—10 feet in diameter and 46½ inches deep—have been formed to final shape with a single explosive charge. Each part weighs half-a-ton and is as thick as the body of an armored car.

These domes will not be used in operational equipment. They will be part of a rugged test program in which they will be compared to space booster domes formed by bending and welding smaller segments on conventional factory tools.

The forming took place in a 105-foot-diameter pool of water located at the Martin Company plant near Denver. To form each dome a single shot using 26.8 pounds of high explosive forced the sheet of heavy gauge aluminum into a bowl-shaped fiberglass die.

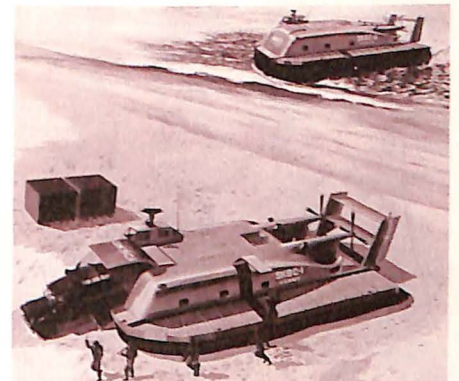

Water-Skimming Cargo Craft Proposed by Bell

Water-skimming cargo craft—supported on a cushion of air—have been proposed by Textron's Bell Aerosystems Company for unloading military supplies faster and more cheaply off the coast of Vietnam.

The new cargo craft would travel from shipside to shore at speeds up to 60 knots and could cross beaches, rice paddies and even rock-strewn fields.

There are few good harbors in South Vietnam and they are congested. The proposed water-skimming cargo craft would replace the lighters presently being used to transport cargo from ocean-going ships to beaches and small docks.

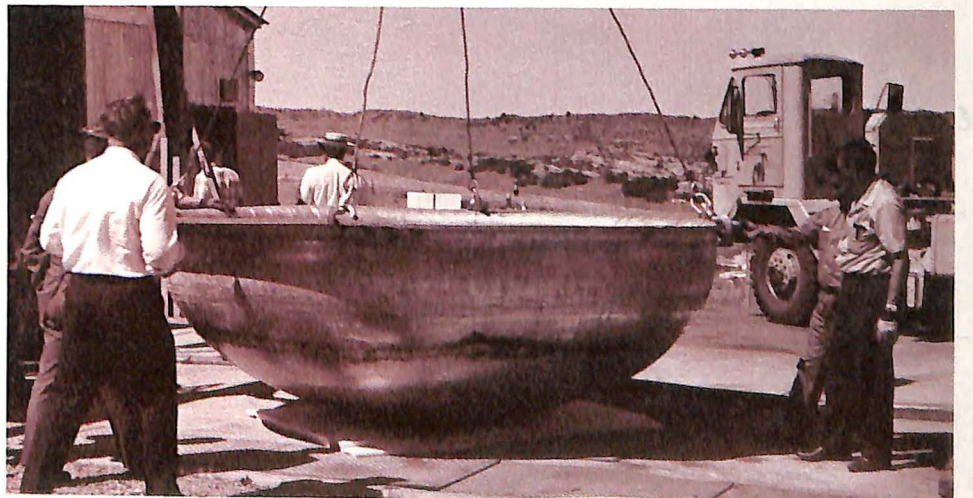

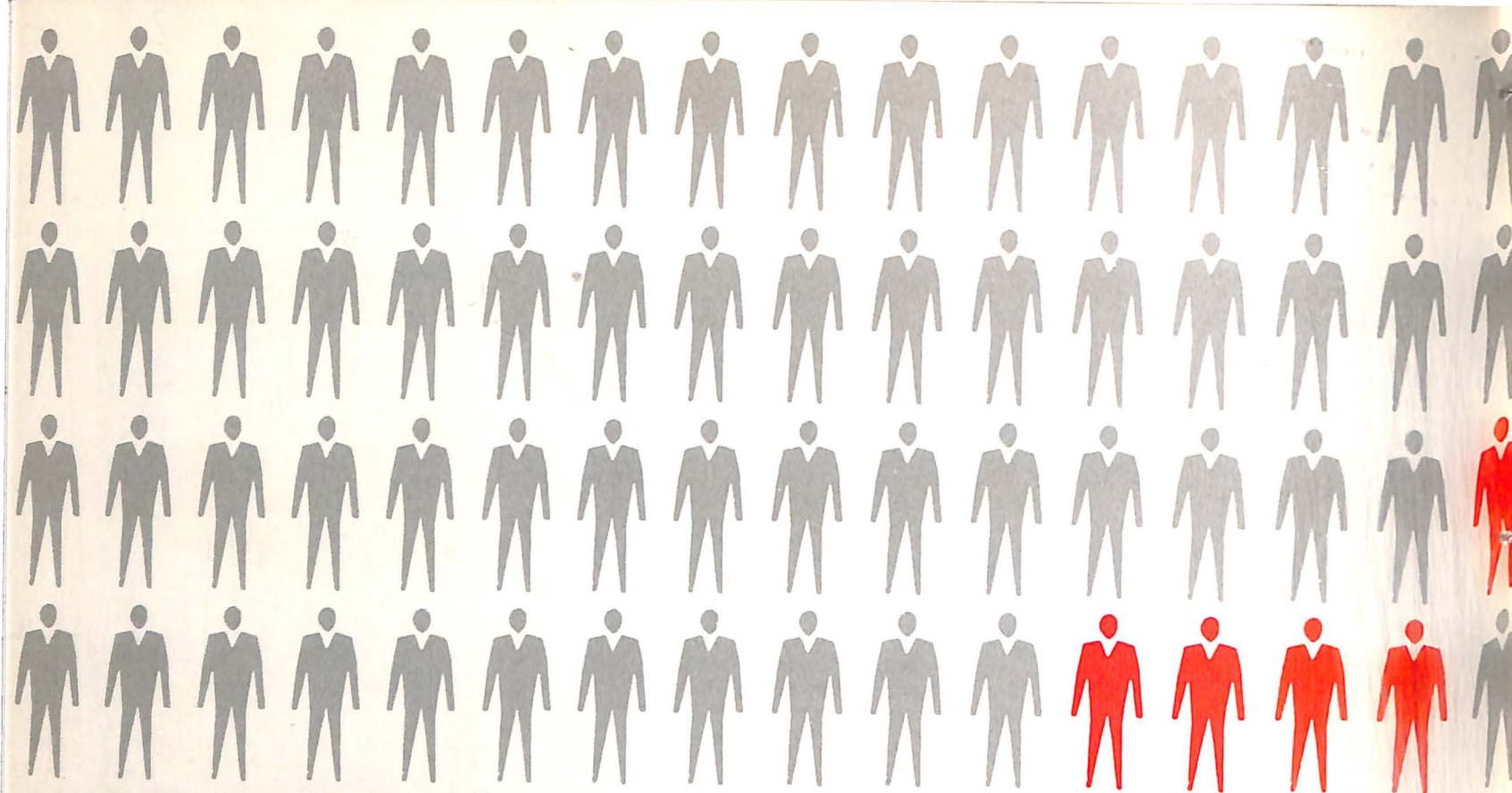

AIRCRAFT PRODUCTION SETS PACE

AEROSPACE EMP



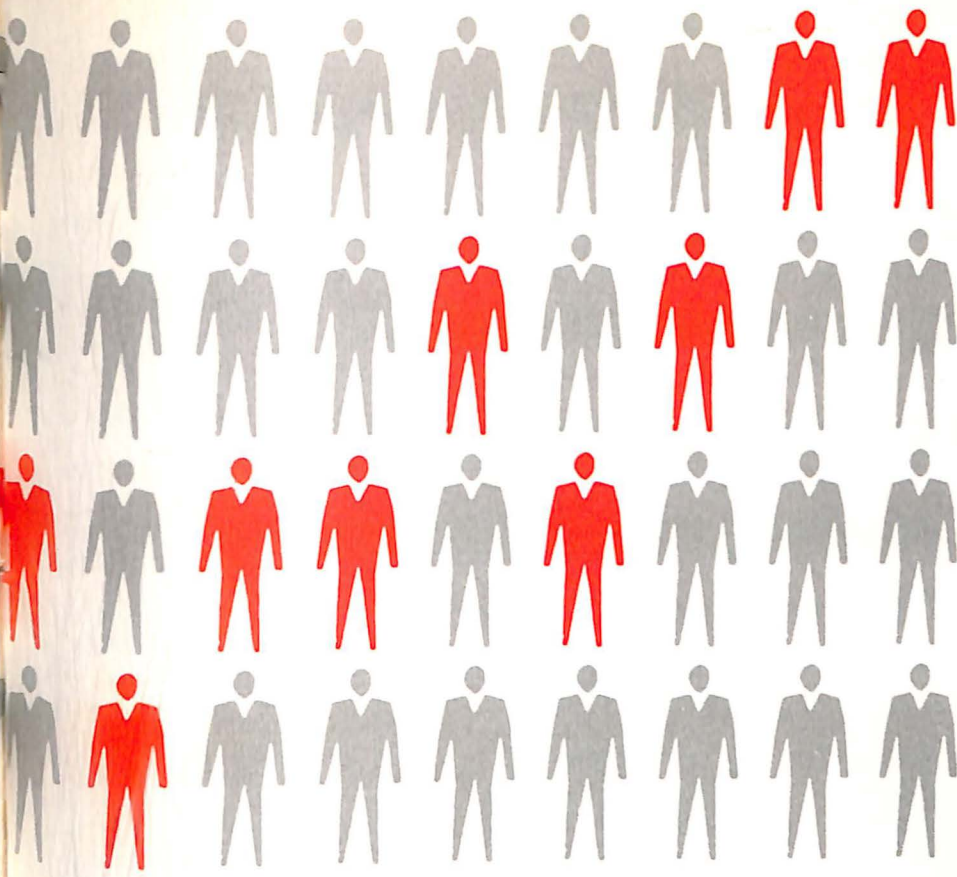

EMPLOYMENT



A prime measurement of the health and stability of the aerospace industry is the level of its employment.

Again this year, as it has for the past seven consecutive years, employment among aerospace manufacturers will exceed a million men and women as it rises to an expected record 1,349,000 total.

To determine the extent of employment growth in this industry, Aerospace Industries Association recently completed a semi-annual survey of 267 plants and facilities of 59 aerospace companies, representing 80 percent of the entire industry. Statistics are broken down into three categories according to primary activity in which the plant or laboratory is engaged. These are aircraft, missiles and space, or non-aerospace.

Based upon the current survey, aerospace employment should by December be about eight percent higher than the 1,247,000 reported employed in the industry in March. Compared to December 1965, the expected total by the end of this year will be 11 percent higher.

Biggest proportion of the gain is in the aircraft segment of the industry. Despite significant accomplishments and advancements in missile and space activities aircraft manufacturing is still the backbone of the industry.

The tremendous backlogs of manufacturers of commercial transports and general aviation aircraft, which are presently at an all time high, underpin the rise of 18 percent in aircraft employment anticipated in the December 1965 to December 1966 period.

Stimulated by rising incomes among an expanding population, airlines are booming to meet increasing passenger and cargo demands. There is also increased interest among corporations and private citizens in having aircraft of their own as reflected in monthly production figures.

The military need for aircraft in Vietnam, which includes everything from long-range bombers to high

EMPLOYMENT OF SCIENTISTS AND ENGINEERS IN THE AEROSPACE INDUSTRY

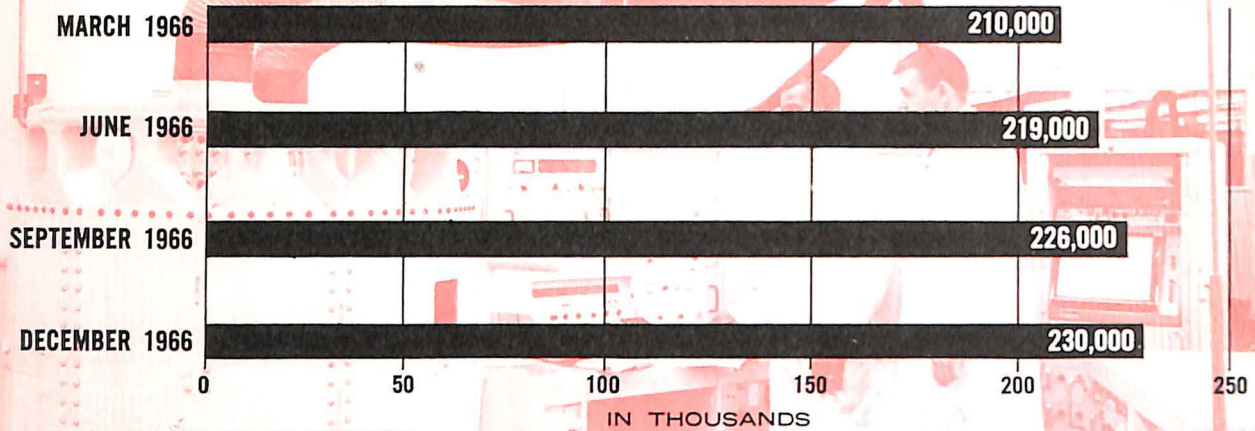

AIA ECONOMIC DATA BRANCH ESTIMATES

performance fighters to helicopters to the low-flying single engine aircraft used by forward air controllers, is making aircraft the primary weapon in that conflict.

With this situation in both military and commercial aviation, employment in this area of the industry will continue to rise.

Employment in companies involved primarily in production of missiles and space hardware, on the other hand, is remaining fairly stable. By December the companies responding to the survey anticipate only slight increases in employment owing to peaking of space expenditures in calendar year 1966 which is having the effect of increasing employment through the remainder of the year. Missile employment has stabilized as production of some of the nation's larger missile systems is phasing out, and production of Poseidon, Minuteman III and smaller missile systems increases.

The third segment of the industry, that involved in non-aerospace activities, expects a 13 percent increase in employment by the end of the year above last

March. This is the portion of the industry which employs personnel on projects not directly related to aerospace in which industry's technological know-how and systems management capabilities are applied to other efforts.

As Karl G. Harr, Jr., president of AIA, recently stated:

"Aerospace companies are in the forefront of developing high-speed trains, radically new ships, transportation systems in underdeveloped countries, water and air pollution control systems, oceanology systems, job training and information collecting systems and a thousand other products and systems related to the obvious future market."

Of the total employment, more than 50 percent is made up of production workers. Scientists and engineers make up approximately 17 percent and technicians, seven percent.

By December, the industry expects to employ 13 percent more technicians than it did in March; most of this increase will be in aircraft manufacturing firms.

COMMERCIAL TRANSPORT AIRCRAFT EMPLOYMENT IN THE UNITED STATES

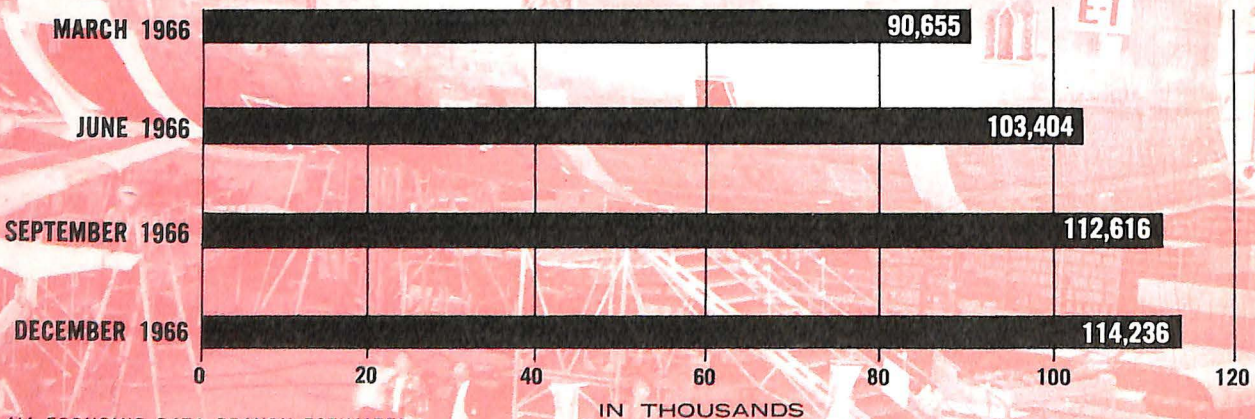

AIA ECONOMIC DATA BRANCH ESTIMATES

DISTRIBUTION BY PERCENTAGE OF EMPLOYMENT IN THE AEROSPACE INDUSTRY BY GEOGRAPHIC AREA

Geographic Area	March 1966	June 1966	September 1966	December 1966
NEW ENGLAND AND MIDDLE ATLANTIC	20.8	20.5	20.6	20.9
EAST NORTH CENTRAL	4.5	4.6	4.6	4.5
WEST NORTH CENTRAL	8.4	8.3	8.1	7.9
SOUTH ATLANTIC	9.0	9.1	9.2	9.5
SOUTH CENTRAL	5.4	5.5	5.6	5.6
MOUNTAIN	2.4	2.4	2.4	2.4
PACIFIC	40.6	40.6	40.6	40.3
UNDISTRIBUTED	8.9	9.0	8.9	8.9

Derived from data supplied, by member companies on 267 establishments, to AIA. Geographic area boundaries follow those of the U.S. Bureau of the Census.

About ten percent more scientists and engineers will be employed in December than in March. Growing demand for scientists and engineers is primarily found among companies involved in transport aircraft where research and development continues on new advanced transports. The increase in this employment is expected to be 32 percent between March and December.

Employment of scientists and engineers in missile and space companies and in the non-aerospace areas of activity is expected to remain relatively stable during the nine-month period.

Geographically, the distribution of aerospace employment is characterized by relative stability with no substantial regional shifts compared to recent past surveys. Actually, changes in the proportion of employment as compared with the previous survey are largely the result of more companies reporting.

Ninety-seven percent of transport aircraft employment is in the Pacific region, primarily in California and Washington, home of Douglas Aircraft and The Boeing Company, major producers of the big trans-

ports. And it is in this region also that 40 percent of the total industry employment is centered, according to AIA's survey.

Seventy percent of the nation's helicopter manufacturing employment is found in the New England and Middle Atlantic regions, chiefly Connecticut and Pennsylvania.

General aviation aircraft manufacturing appears to be the most widely dispersed judging from the geography of employment in that segment of the industry. The survey reveals that 66 percent of this employment is located in the North Central area of the country, primarily in Ohio and Kansas.

It is evident from this survey that the aerospace industry is continuing to grow at a fairly rapid pace with no apparent slackening of the forces generating this rise. Although missile and space employment is expected to increase only modestly, increasing activity in commercial and military aircraft production and in non-aerospace areas is providing the basis for further industry growth.

UTILITY AIRCRAFT EMPLOYMENT IN THE UNITED STATES

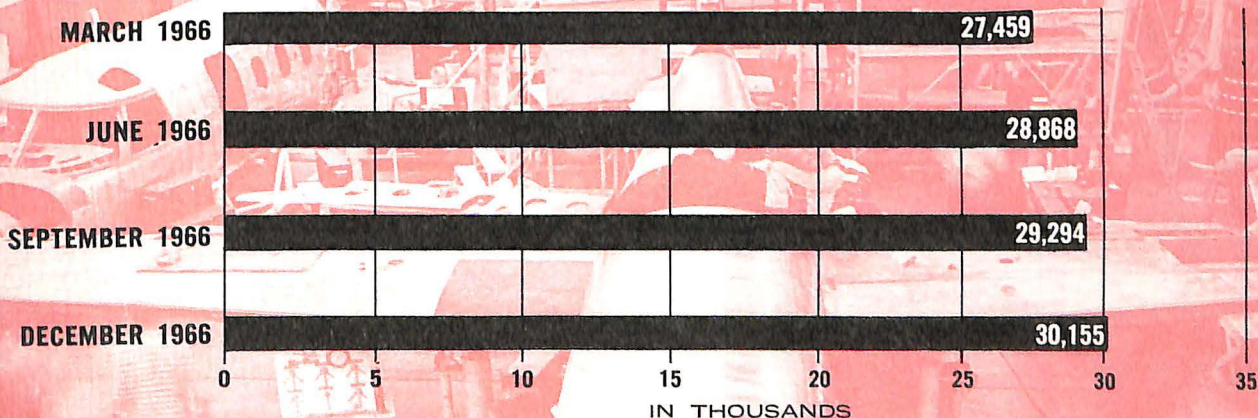

AIA ECONOMIC DATA BRANCH ESTIMATES

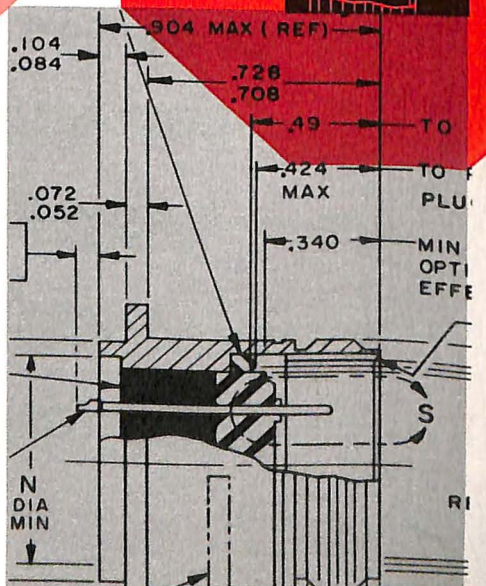
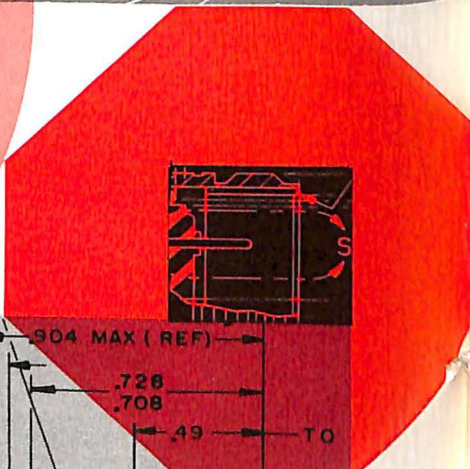
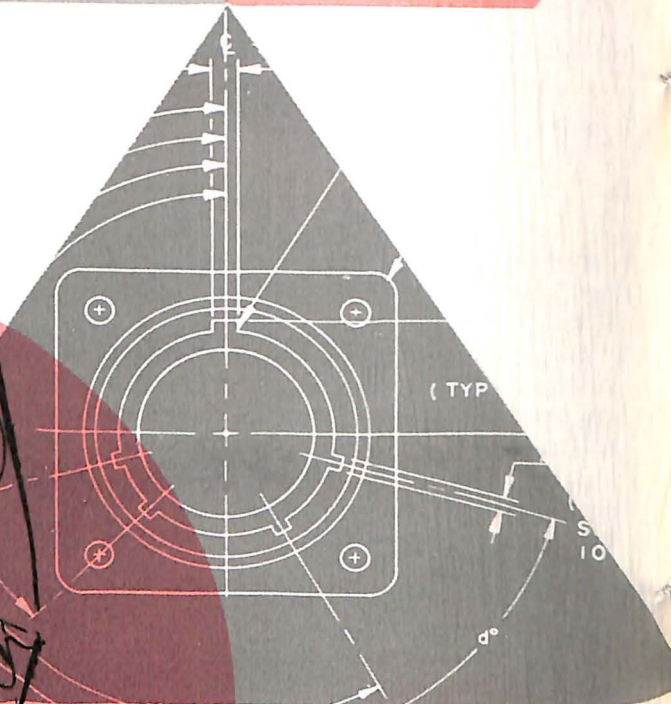
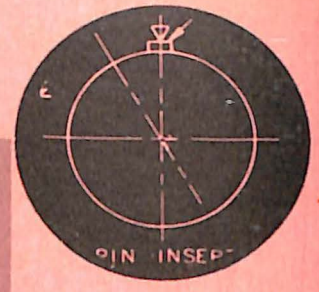
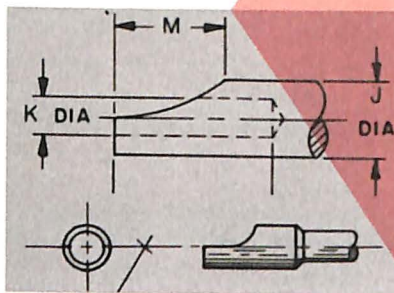

National Aerospace Standards

KEY TO EXCELLENCE

By JOHN F. CRAMER

Standards of a wide and widening variety are basic to most of man's activities. For example, time is defined by a standard, and clothes are sized by standards.

In the aerospace industry, much of the high performance, reliability and economical operation of aerospace products is directly due to aerospace standards. These are prepared and issued by the Aerospace Industries Association's National Aerospace Standards Committee, which this year marks its 25th anniversary.

National Aerospace Standards are a series of industry-developed standards covering such aerospace hardware as fasteners, fittings and electrical items, specifications for aerospace materials, packaging materials, machine tools and test procedures.

During its 25 years of existence, NASC has generated and issued more than 1,100 standards and specifications. All military and commercial aircraft and their supporting equipment built since World War II contain numerous National Aerospace Standards parts. Today's spacecraft, of course, are using them, too.

Standardization in the aerospace industry offers cost savings, as well as reliability, to a greater extent today than ever before. The cost reduction of using a standard part is obvious. But the not-so-obvious savings are even greater. An aerospace company adopting an industry standard does not make the considerable investment in developing its own standard. There are usually significant savings in weight, and a weight savings in an aerospace vehicle can be more valuable than a demonstrable dollar savings.

These factors become more meaningful as production of sophisticated aerospace vehicles has declined in comparison with volume production quantities, and the elimination of standards development costs for individual companies represents a major cost reduction area.

The proposal for a National Aerospace Standard starts with the recognition by one or more aerospace companies of the necessity for an industry-wide sharing of a design, material or process which would produce savings or increase reliability. The views of all members of the NASC are requested and, if approved, a proposed standard is prepared. This standard requires the approval of a majority of members. The standard is assigned a number, printed and distributed throughout industry.

The National Standards Association publishes and distributes National Aerospace Standards for AIA.

John F. Cramer, Chief, Standards and Specifications, The Boeing Company, and National Chairman of AIA's National Aerospace Standards Committee for 1966, has served continuously with the NASC since its establishment 25 years ago.



Automatic distribution of current standards is made to more than 1,000 companies, government agencies, colleges, technical schools, libraries and individuals. International distribution includes 24 foreign nations.

The surging advances of technology in the aerospace industry caused the NASC to request liaison representatives from government agencies to serve with the committee. NASC activities today are integrated with corresponding activities of the Army, Navy, Air Force, Aeronautical Standards Group, Defense Supply Agency and the National Aeronautics and Space Administration. The committee meets three times a year with government representatives. One of the principal benefits of the across-the-table meeting among aerospace company representatives and government is the opportunity to discuss changes in military standards.

The acceptability of industry-sponsored and industry-produced standards is evident in the action of government agencies.

The Air Force has accepted all active National Aerospace Standards for use by contractors in the absence of a comparable government standard without further approval by the procuring agency. The majority of industry standards are accepted by the Navy.

A comprehensive report, made for the Department of Commerce, recommended a national body for voluntary standardization with a government charter, which would coordinate the development of standards by associations and technical societies and produce a consensus of "U. S. A. Standards" as the official voice of the nation in international standards activities. The report cited NASC as meeting "a real and vital need in the performance and reliability requirements of weapon systems."

NASC, with its quarter-century of experience, will continue to make standards a key to excellence in the aerospace industry.



Senator Monroney

SST

Interaction of Technology

The following is excerpted from remarks by Senator A. S. Mike Monroney before the Air Force Association's Annual Fall Meeting.

The true military potential of the SST isn't likely to be realized until the commercial version has grown in range and payload. I call your attention to recent NASA findings which indicate future SSTs could operate at a lift-over-drag ratio of ten at about Mach 3.5 — compared to the 8.2 L over D or so of the first-generation SST. This would be a quantum jump and make supersonic flight much more attractive than even the most optimistic supporters dared hope for.

But you are not going to have a second-generation SST if you don't build a first one and to maintain that the technology flowing out of the commercial SST is of no value to the military is unreasonable. As a matter of fact, it is not true, and I will prove it. The Department of Defense is refusing to disclose certain current SST engine specifications, something our own and foreign airlines that have been asked to help evaluate the competing designs would like to know. At first blush this makes no sense because, after all, we plan on selling this aircraft to anybody who wants to buy it. Nevertheless, the rationale behind this procedure is sound:

If the first SST won't be delivered until eight years from today, and if it can be assumed that within this period our competitors will advance their own state of the art above what it is today, this refusal does make sense indeed. Of course, it confirms that engines capable of turning out up to 80,000 pounds of thrust are of military value, especially if they meet the fuel economy, maintainability, and reliability requirements of commercial aviation. This *does* represent a *definite* advance in the state of the art over the existing military engines. The military will also benefit from the SST materials technology, its communications systems, guid-

ance, hydraulics, and in many other ways.

In addition, it can be argued that the price of sophisticated materials, of engines, and so on, will come down because of the SST

It would seem, then, that the argument that the SST does not benefit our defense posture simply does not hold water. As we would say back in Oklahoma, the better the stud, the better the breed. That, I think, sums up the relationship between the SST's technology and coming generations of military aircraft.

We could call this spin-off from the SST into the military. There will be spin-off from this supersonic technology into industry in general and into the consumer field. Among Emperor Napoleon's most treasured possessions was a set of aluminum dishes. Then aluminum was more expensive than platinum. Now we use aluminum in throw-away cans and foil, in the family automobile, and for window screens. The SST, I predict, will do the same for titanium.

Most of all, I would hope titanium will eventually be used to build safer automobiles. The most dangerous part of an SST trip will still be getting to the airport by car.

I urge the aerospace industry to contribute its best thinking to the solution of problems of this kind.

I have brought out these fringe benefits of the SST with a particular thought in mind: This aircraft has been portrayed as a frivolous luxury, as a conveyance of the idle rich superjet set. Of course, ten years ago, this was being said about the jets.

These examples show that the SST is typical of the interaction between technology and society, affecting profoundly society's progress and well-being.

England's current trouble has been diagnosed as a

nd Society

case of technology neglected. But right here in the United States, our maritime industry is about 20 years behind the times. I only hope that the Navy's Fast Deployment Logistics program, for which a number of aerospace companies are competing, will enable us to catch up.

Passenger service on most of our railroads is pitiful. The only ray of hope is the current effort to develop high-speed trains employing jet propulsion, light metals, and other aerospace techniques.

Starving technology mortgages the future of our society. Twenty years ago, Britain picked immediate social goals over technological progress. Today, it is paying the price, lacking the production base to support either social or technical progress.

There are pressing social problems in need of more money. We all know that. And I would be the last person to wench on our duty to give our troops in Vietnam every last iota of material assistance that they need. But technology does not take food out of the mouths of the poor or short-change our GIs. If we want to fight the social war to victory and end the military war, now and for the future, we need technology more than ever. It is right here that the aerospace community — government and industry, military and civil — can make its greatest contribution.

For, the stringent requirements of aerospace hardware have shaped and guided modern technology. And aerospace has given us the systems approach to large management problems. The techniques and procedures that have spawned near-miracles in transportation, communications, weaponry, and space exploration can be applied both profitably and in the national interest to pressing problems on the socio-economic side

AIA

Manufacturing Members

Abex Corporation
Aerodex, Inc.
Aerojet-General Corporation
Aeronca, Inc.
Aeronutronic Division, Philco Corporation
Aluminum Company of America
Avco Corporation
Beech Aircraft Corporation
Bell Aerospace Corporation
The Bendix Corporation
The Boeing Company
Cessna Aircraft Company
Chandler Evans, Inc.
Control Systems Division of
Colt Industries, Inc.
Continental Motors Corporation
Cook Electric Company
Curtiss-Wright Corporation
Douglas Aircraft Company, Inc.
Fairchild Hiller Corporation
The Garrett Corporation
General Dynamics Corporation
General Electric Company
Defense Electronics Division
Flight Propulsion Division
Missile & Space Division
Defense Programs Division
General Laboratory Associates, Inc.
General Motors Corporation
Allison Division
General Precision, Inc.
The B. F. Goodrich Company
Goodyear Aerospace Corporation
Grumman Aircraft Engineering Corp.
Gyrodyne Company of America, Inc.
Harvey Aluminum, Inc.
Hercules Incorporated
Honeywell Inc.
Hughes Aircraft Company
IBM Corporation
Federal Systems Division
International Telephone & Telegraph Corp.
ITT Federal Laboratories
ITT Gilfillan, Inc.
Kaiser Aerospace & Electronics Corporation
Kaman Aircraft Corporation
Kollsman Instrument Corporation
Lear Jet Industries, Inc.
Lear Siegler, Inc.
Ling-Temco-Vought, Inc.
Lockheed Aircraft Corporation
The Marquardt Corporation
Martin Company
McDonnell Company
Menasco Manufacturing Company
North American Aviation, Inc.
Northrop Corporation
Pacific Airmotive Corporation
Piper Aircraft Corporation
PneumoDynamics Corporation
Radio Corporation of America
Defense Electronic Products
Rockwell-Standard Corp.
Aircraft Divisions
Rohr Corporation
Ryan Aeronautical Company
Solar, Division of International
Harvester Co.
Sperry Rand Corporation
Sperry Gyroscope Company
Sperry Phoenix Company
Vickers, Inc.
Sundstrand Aviation, Division of
Sundstrand Corporation
Thiokol Chemical Corporation
TRW Inc.
United Aircraft Corporation
Westinghouse Electric Corporation
Aerospace Electrical Division
Aerospace Division
Astronuclear Laboratory
Marine Division

See *Aerospace Employment*, page 10

AEROSPACE EMPLOYMENT

The chart shows the changes in aerospace employment by total and type of product, comparing the employment at the end of 1965 and the estimated employment for December 1966. Non-aerospace employment, which is not shown on the chart, is expected to reach 61,000 by the end of 1966.

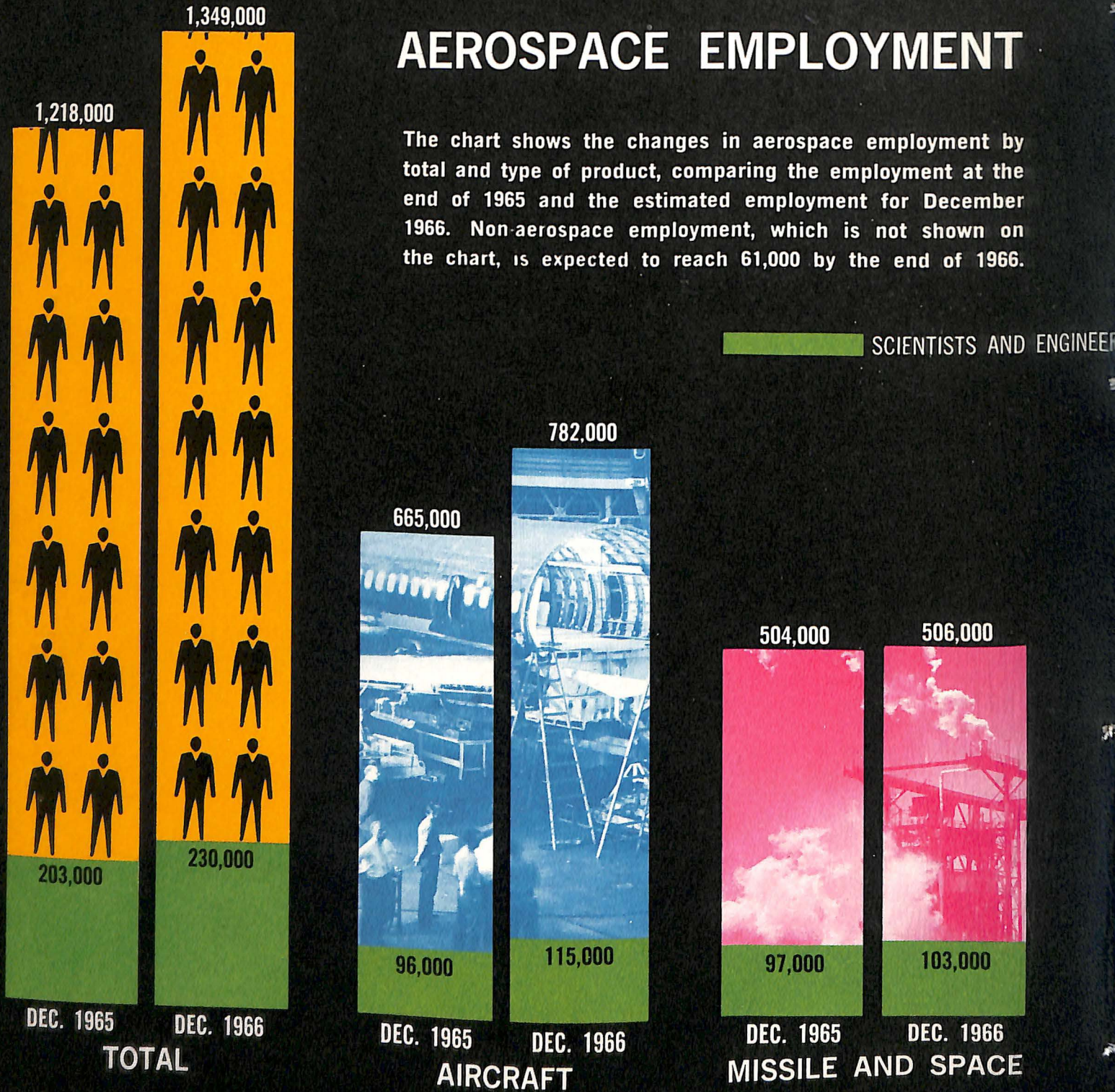

aerospace

OFFICIAL PUBLICATION OF THE AEROSPACE INDUSTRIES ASSOCIATION • NOVEMBER 1966

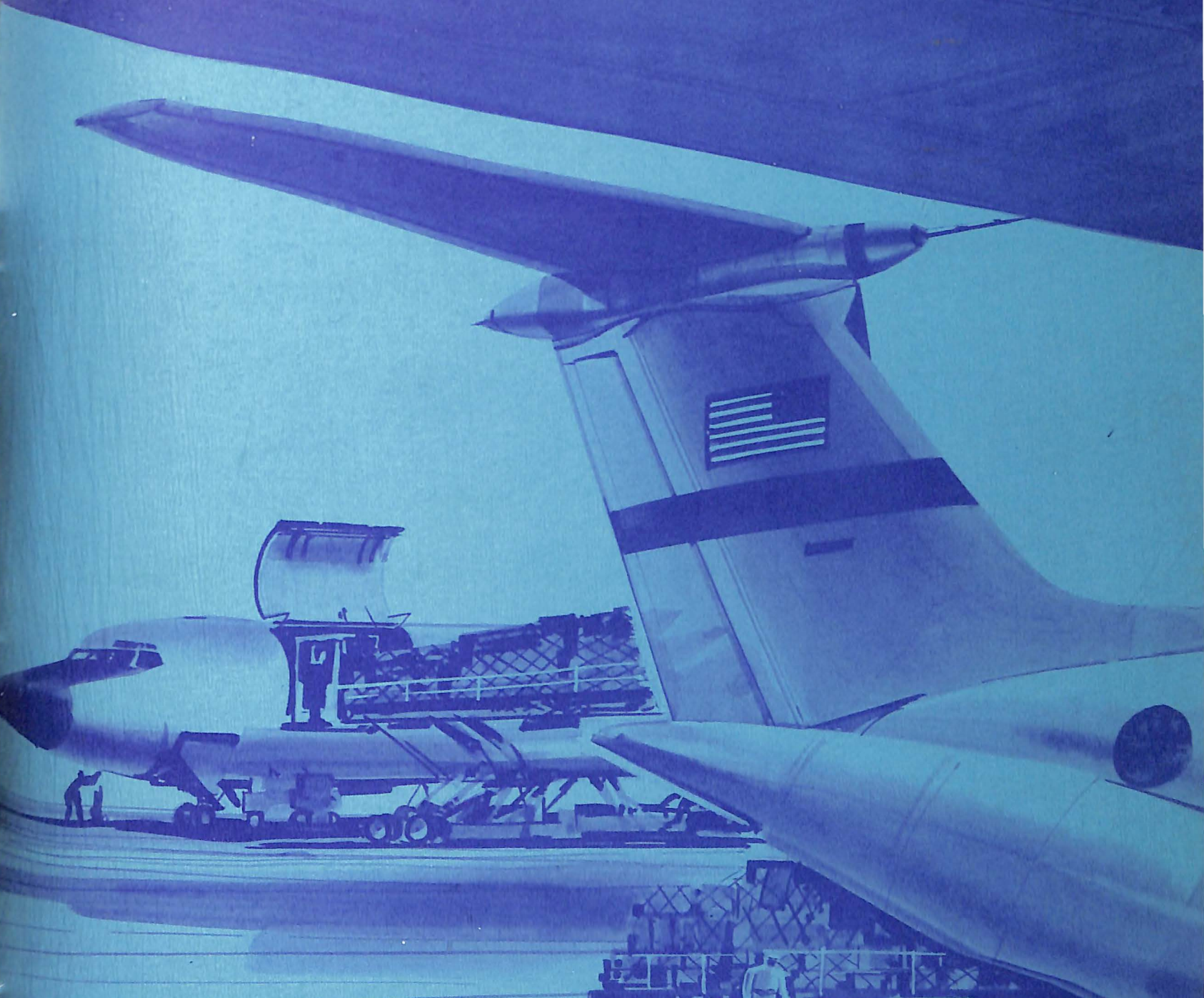

- AIRLIFT TO VIETNAM —
Soaring Support
- AEROSPACE MEASUREMENTS —
Quest For Accuracy



AEROSPACE ECONOMIC INDICATORS

CURRENT

OUTLOOK

Total Aerospace Sales

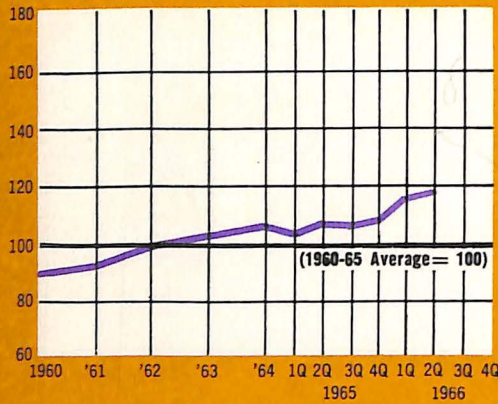

Value of Civil Aircraft Shipments

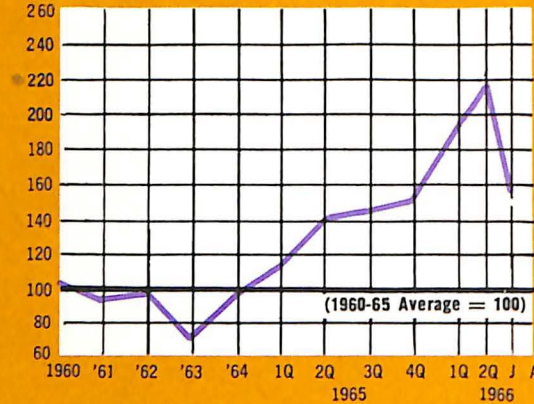

New Orders — Monthly Average

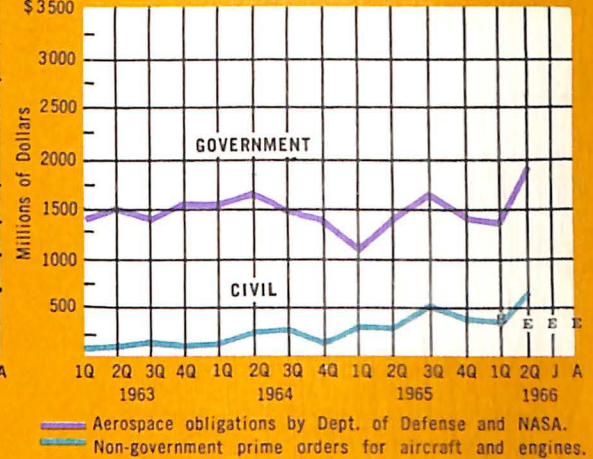

ITEM	UNIT	PERIOD	1960-65 AVERAGE *	LATEST PERIOD SHOWN	SAME PERIOD YEAR AGO	PRECEDING PERIOD †	LATEST PERIOD
AEROSPACE SALES: Total	Billion \$	Annual Rate	19.4	Quarter Ending June 30	20.8	22.4	22.8[‡]
	Billion \$	Quarterly	4.8	1966	5.4	5.6	5.8
DEPARTMENT OF DEFENSE							
Aerospace obligations: Total	Million \$	Monthly	1,151	June 1966	1,440	785	2,770 [‡]
Aircraft	Million \$	Monthly	601	June 1966	862	584	2,039
Missiles & Space	Million \$	Monthly	550	June 1966	578	201	731
Aerospace expenditures: Total	Million \$	Monthly	1,067	June 1966	785	759	1,366 [‡]
Aircraft	Million \$	Monthly	561	June 1966	520	528	853
Missiles & Space	Million \$	Monthly	506	June 1966	265	231	513
NASA RESEARCH AND DEVELOPMENT							
Obligations	Million \$	Monthly	215	Aug. 1966	272	764	319
Expenditures	Million \$	Monthly	180	Aug. 1966	372	409	376
UTILITY AIRCRAFT SALES							
Units	Number	Monthly	692	Sep. 1966	834	1,266	1,522
Value	Million \$	Monthly	15	Sep. 1966	26	36	39
BACKLOG (60 Aerospace Mfrs.): Total	Billion \$	Quarterly	15.3 #	Quarter Ending	16.7	22.1	22.8
U.S. Government	Billion \$	Quarterly	11.6	June 30	11.8	14.3	13.7
Nongovernment	Billion \$	Quarterly	3.7	1966	4.9	7.8	9.1
EXPORTS							
Total (Including military)	Million \$	Monthly	110	Aug. 1966	141	109	114
New Commercial Transports	Million \$	Monthly	24	Aug. 1966	54	18	29
New Utility Aircraft	Million \$	Monthly	2	Aug. 1966	4	9	10
PROFITS							
Aerospace — Based on Sales	Percent	Quarterly	2.3	Quarter Ending June 30	3.1	3.1	3.2
All Manufacturing — Based on Sales	Percent	Quarterly	4.8	1966	5.8	5.6	5.9
EMPLOYMENT: Total	Thousands	Monthly	1,132	Aug. 1966	1,162	1,311	1,324[‡]
Aircraft	Thousands	Monthly	499	Aug. 1966	463	570	575
Missiles & Space	Thousands	Monthly	496	Aug. 1966	529	569	576
AVERAGE HOURLY EARNINGS, PRODUCTION WORKERS	Dollars	Monthly	2.92	Aug. 1966	3.17	3.38	3.43[‡]

[‡] Estimate

* 1960-65 average is computed by dividing total year data by 12 or 4 to yield monthly or quarterly averages.

† Preceding period refers to month or quarter preceding latest period shown.

Averages for 1961-65.

1966 AEROSPACE SALES MOVE TOWARD RECORD

Sales in the aerospace industry will reach a new record of more than \$22.5 billion in 1966, an increase of nearly eight percent over the \$20.9 billion in sales during 1965.

Sales of commercial and military aircraft are expected to increase to more than \$11.3 billion compared to \$9.7 billion in 1965. Sales of missiles in 1966 are expected to remain at the \$3.6 billion level of last year. Relative stability is also anticipated in the sales of space vehicles, which should approximate \$5.3 billion in 1966. Sales of nonaerospace products and services by aerospace manufacturers should increase to about \$2.3 billion in 1966 from \$2.2 billion in 1965.

Aircraft sales is currently the primary growth force in the aerospace industry. Commercial transports on order now approximate \$4.7 billion. The recent announcement by the Department of Defense of the purchase of 780 tactical aircraft in Fiscal Year 1968, valued at \$700 million, provides strength to the military aircraft outlook.

Deliveries of jet transport aircraft in 1966 are expected to approximate \$1.8 billion. Military aircraft shipments consist primarily of fighters and helicopters for use in Vietnam.

Space expenditures — both civilian and military — should stabilize at around \$5.3 billion in 1966. The civilian space program is anticipated to remain relatively stable.

Expenditures for missiles are expected to stabilize at around \$3.6 billion in 1966. Gaps left by the phasing out of some projects will be filled by increased activity on the Minuteman II and the Poseidon missile programs.

Activities not directly related to aviation and space are expected to rise in 1966. These sales should approximate \$2.3 billion in 1966 compared with about \$2.2 billion in 1965.

Shipments of aircraft in 1966 will be substantially higher than in 1965. Total civil aircraft shipments should approximate \$2.8 billion in 1966 as compared with \$1.7 billion in 1965. Shipments of general aviation aircraft are estimated to exceed 16,000 aircraft in 1966 compared with less than 12,000 in 1965. The dollar value of these aircraft is estimated to increase from \$318 million to over \$410 million between 1965 and 1966.

Exports of aerospace products in 1966 will constitute seven percent of total industry sales. Exports by the aerospace industry are expected to reach a postwar record of \$1,550 million in 1966, an increase of more than five percent over the \$1,474 million reported in 1965. This is the ninth year since World War II that aerospace exports will have exceeded \$1 billion.

These rising levels in the economic activity of the aerospace industry are not temporary. Increasing markets for exports and domestic commercial and military aerospace products indicate that the growth will continue.



aerospace

Official Publication of the
Aerospace Industries Association of America, Inc.

PRESIDENT • Karl G. Harr, Jr.
PUBLISHER • Glen Bayless

VOL. 4, NO. 9

NOVEMBER 1966

EDITOR • Gerald J. McAllister
ASSOCIATE EDITORS • Richard W. Balentine
• William S. Evans
• John J. Lee
ECONOMIST • Gerson N. Chanowitz
ART DIRECTOR • James J. Fisher

CONTENTS

2 AIRLIFT TO VIETNAM — SOARING SUPPORT

8 AEROSPACE NOTES

10 AEROSPACE MEASUREMENTS — QUEST FOR ACCURACY

14 SPACE IN TEXAS

The purpose of AEROSPACE is to:

Foster understanding of the aerospace industry's role in insuring our national security through design, development and production of advanced weapon systems;

Foster understanding of the aerospace industry's responsibilities in the space exploration program;

Foster understanding of civil aviation as a prime factor in domestic and international travel and trade;

Foster understanding of the aerospace industry's capabilities to apply its techniques of systems analysis and management to solve local and national problems in social and economic fields.

AEROSPACE is published monthly by the Aerospace Industries Association of America, Inc., the national trade association of the designers, developers and manufacturers of aircraft, missiles, spacecraft, their propulsion, navigation and guidance systems and other aeronautical systems and their components.

Publication Office: 1725 De Sales Street, N.W., Washington, D. C. 20036

Western Office: McCulloch Building, 6151 West Century Blvd., Los Angeles, Calif. 90045

*All material may be reproduced with
or without credit.*

AIRLIFT TO

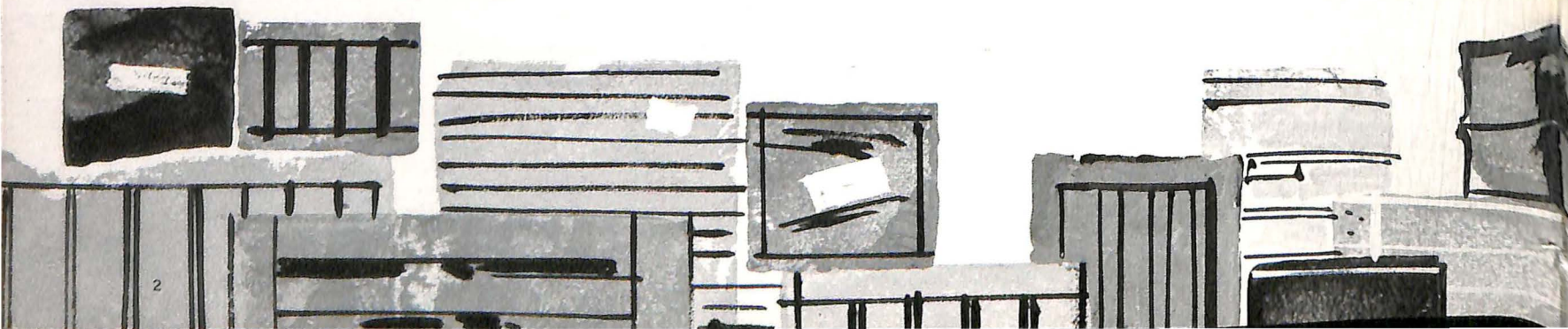

VIETNAM

Soaring Support

A huge Lockheed C-141 Starlifter settles lightly down onto the runway at Tan Son Nhut Air Base in the Republic of Vietnam — its wings drooping as though the big bird were tired after its long flight from the United States.

The impression is quickly dispelled when, with the aircraft's engines still running, large, strange-looking vehicles move to the Starlifter's open rear cargo doors and unload some 50,000 pounds of palletized cargo. Total unloading time: twenty minutes. Total time before the big bird takes to the air again, looking for all the world as if it were about to flap its wings: one hour and a half.





Douglas C-124 Globemaster can carry 50,000-pound payload across a 2,300-mile range.

The activity looks frantic, but actually it is the routine work of efficient professionals using the best equipment available in the world today. The off-loading vehicles are part of the Douglas-developed automated Materials Handling System, which has drastically reduced the time required to load and unload Military Airlift Command (MAC) aircraft.

The Starlifter is the newest aircraft in MAC's inventory. As soon as Lockheed began delivering the aircraft, MAC accelerated the phase involving testing by the using command, as well as the transition training of

crews to fly it. MAC needed the big aircraft quickly if it was to meet the soaring demands for airlift in support of our Southeast Asia operations.

These requirements continue to grow, month by month, keeping every type of large transport in the airlift command's inventory, as well as many civil air carriers under Air Force contract, straining to keep up with the need. Roughly seventy-five percent of the MAC capability is presently devoted to supplying our forces in Southeast Asia.

The Douglas C-124 Globemaster, with a range of

Lockheed C-130 Hercules is used in the U. S. to Vietnam aerial supply line, and also in cargo operations in Vietnam. Photo at right shows fuel drums being loaded into the Hercules at Tan Son Nhut Air Base in the Republic of Vietnam.



2,300 miles carrying a 50,000-pound payload, is still hauling a healthy share of the cargo that travels over the Pacific. Its huge clam-shell nose doors allow almost any large vehicle in the Army inventory to be driven in and transported fully assembled.

And the giant turboprop Douglas C-133 Cargomaster, still the largest operational aircraft in the Air Force, continues to be a dependable workhorse. Its 90-foot-long cargo hold can take 100,000 pounds of cargo or 16 loaded jeeps, or 200 passengers.

The dependable Lockheed C-130 Hercules, largely known as a tactical transport, is also making numerous flights across the Pacific.

Increasingly, the Air Force is calling upon the commercial carriers to augment its capability. In the last Fiscal Year, MAC bought nearly \$400 million worth of commercial airlift, the great majority of it going to Southeast Asia. Contracts in Fiscal Year 1967 are expected to go above \$500 million.

Boeing 707 and Douglas DC-8 jets, as well as the CL44 turboprop transport, are carrying 80,000 people and 5,700 tons of cargo a month over the Pacific.

Overall, MAC moved some 800,000 men and 250,000 tons of cargo to support Southeast Asia operations in the last fiscal year. This required an average of 230 flights a day.

The statistics reflecting the way the job is growing are even more impressive. The FY 1966 figures represent a fifty percent increase over the previous year. Missions to Vietnam have increased from 550 in the



Douglas C-133 Cargomaster, largest operational aircraft in the Air Force, can take 100,000 pounds of cargo in its 90-foot cargo hold.

month of August 1965 to 900 in the same month in 1966. Tonnages shipped to Southeast Asia by air have *tripled* during this period, Assistant Secretary of Defense for Installations and Logistics Paul R. Ignatius reported. The Air National Guard and Air Force Reserve alone, flying Boeing C-97s, Lockheed C-121s, and Douglas C-124s, are making almost 150 trips a month.

But as the requirement for airlift to Vietnam has increased, so has the Air Force airlift capability — although it has not yet been able to keep up. General Howell M. Estes, Jr., MAC Commander, said recently that “[We are] . . . still facing a monthly deficit in moving cargo.”

Many factors, reflecting the high quality of the men involved as well as the excellence of the equipment they operate, are responsible for keeping the flow of vital high-priority cargo streaming into Vietnam:

- A searching priority system topped by The Red Ball Express. Reminiscent of the World War II truck resupply line across Normandy, Red Ball is designed to deliver the highest priority cargo, mostly repair parts for major equipment, into the hands of the men who need it within 168 hours after it is called for.

- MAC’s “Pony Express,” a system whereby fresh crews, prepositioned at staging bases in the Pacific, take over from the crews who bring the big aircraft through the first stages of the Vietnam journey.

- The automated system for loading and unloading cargo, including standardized cargo-handling equipment on the aircraft, special rollerized cargo loading-unloading trucks, and the automated sorting and handling equipment in the terminal.

These are just a few innovations that help make possible the astounding eight-hour-a-day utilization rate for the modern aircraft in the MAC fleet.

Important as all these factors are, these innovations to a great extent are possible because of the C-141. It does the job of four C-124s — for less money. Its longer range makes it possible for MAC to use the shorter Northern Pacific route, saving well over 1,000 miles and almost a full day’s flying time, with only one stop in Alaska on the way. Red Ball cargo can be in Vietnam in as little as nineteen hours after it leaves the

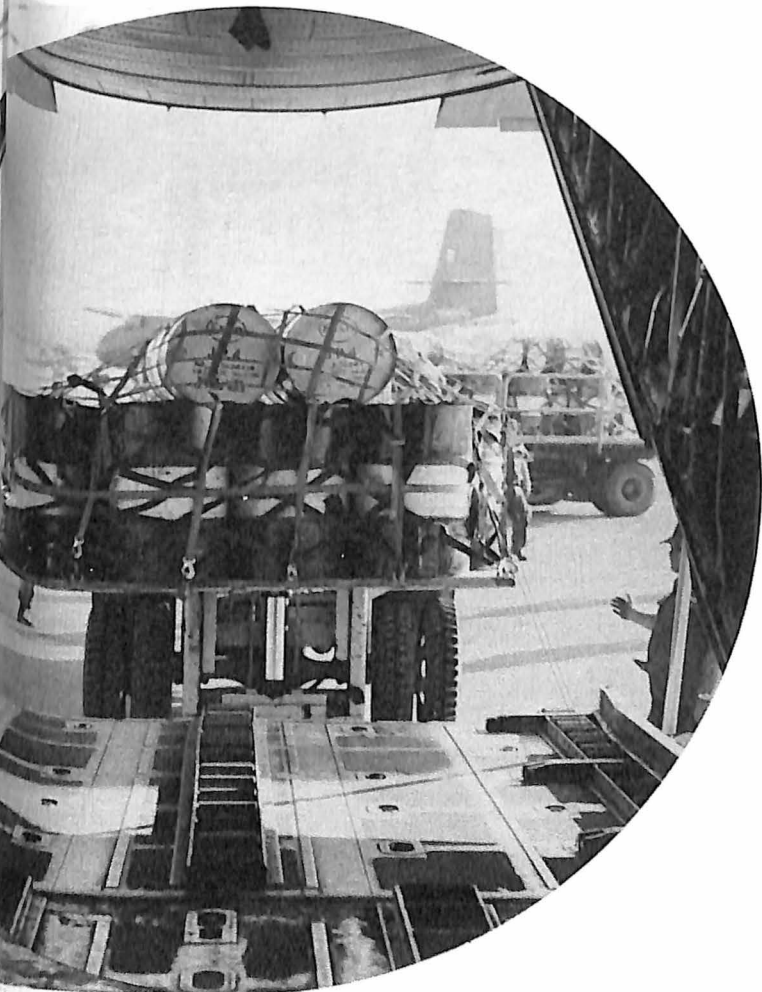

U.S. Shipping directly from the East Coast of the U.S. to Vietnam is also possible because of the Starlifter, saving a week of surface travel across the country.

The aircraft is also making a direct and important contribution to keeping the mortality rate of casualties of the Vietnam war to less than one percent — lower than any war in history. For, on the return trip from Southeast Asia, the Starlifters are turned into flying ambulances carrying patients quickly and comfortably back to the United States, where they can benefit from the modern hospitals and specialists.

With less than 100 C-141s in the fleet in the last fiscal year, MAC airlift to the Pacific area alone during the first six months hit an all-time high. The Lockheed-Georgia Company is speeding delivery of the aircraft. It presently is providing Starlifters to MAC at the rate of about nine a month.

Big as it is, strategic airlift is only part of the job. For in a country where roads and railroads are few, and surface travellers are in constant danger of Viet Cong ambush or sniper fire, aircraft have become the major source of supply and military mobility in the country. Lockheed C-130 Hercules and Fairchild Hiller C-123 Providers are airlifting more than three-fourths of the tonnage required for the support of ground forces in the battle zone. In addition, airlift is proving to be a greater asset in aiding the economic development of the war-torn country. Air Force Chief of Staff Gen. John P. McConnell said recently: "Military airlift [is] demonstrating ways of opening up areas [in Vietnam] that were previously isolated by jungle or mountain barriers . . . providing many of the people in those areas their first access to the markets of Saigon.

"In the long run, these and many similar civic actions under way in South Vietnam may very well be one of our most significant contributions to a lasting peace. . . ."

Coping with short dirt airstrips, bad weather, and Viet Cong firing at them from the ground, the men and airplanes providing intratheater airlift in Vietnam have earned an almost legendary reputation for reliability.

And, just as the demand for strategic airlift is multiplying at a tremendous rate, so too is the requirement for tactical airlift in Vietnam growing fantastically.

For instance, compared to commercial air cargo in the U.S., which has a strong 25-percent a year growth rate, tonnage carried in South Vietnam last year was three times the amount transported by air in 1964. And the 1966 requirement is larger again.

Yet all this — strategic and tactical airlift, in terms

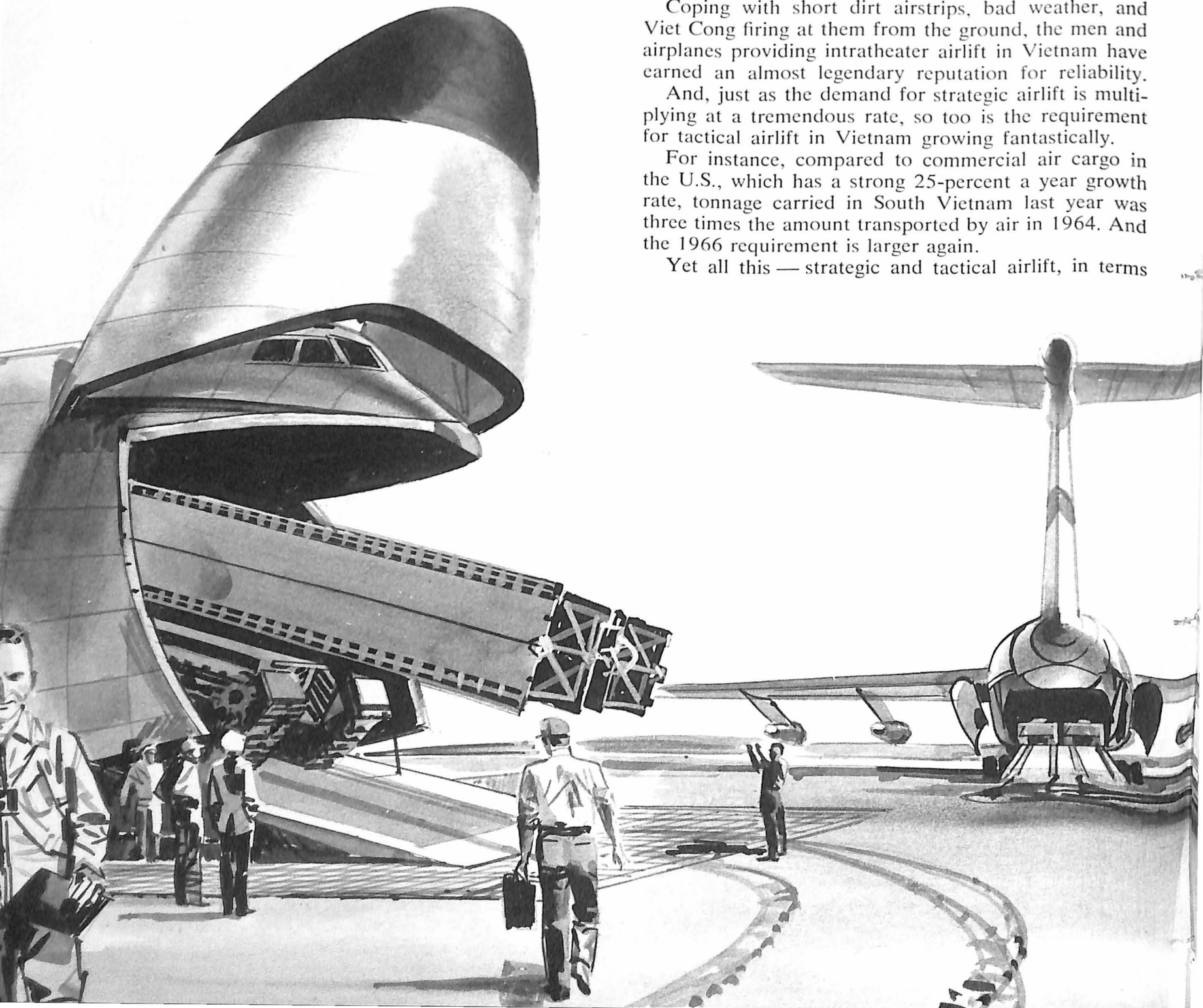



Patients are being loaded aboard the Lockheed C-141 in South Vietnam for air evacuation to the U. S.

of both requirements and capability — will look small relative to what's ahead, according to predictions of leading airlift experts. General Estes sees the multiplying demands for airlift and the fast-growing capability of MAC today as only the first stirrings of a revolution in airlift that is fast gathering force.

"The buildup in Vietnam," he says, "although only one instance of the surging demand, is representative of the entire trend."

The first phase of the revolution, General Estes says, has been reached in that "the obvious advantages of airlift have been accepted as substantially outweighing the limitations."

What about aircraft to meet the demands of this phase of the airlift revolution? General Estes thinks that

although all MAC aircraft presently in the inventory have been essentially a part of the first phase of the airlift revolution, "it was the entry of the fanjet C-141 on the scene that brought airlift within sight of the goal."

When, by 1968, the full complement of 14 groups, some 284 Starlifters, is operating, MAC's airlift capability will be four times what it was in 1961. At this point, in General Estes' terms, we will be "transitioning" into the second phase of the airlift revolution.

The second phase, he states, is when all the traditional limitations on airlift have been essentially eliminated. This day will come when the Lockheed C-5A is delivered in 1969.

The C-5A will, according to the General Estes, "to a very great extent minimize the airlift limitations of the past. It will for the first time permit the MAC force to respond without qualification to total airlift requirements, including the maximum demand — the division-force move. And it will come much closer to putting airlift in a cost competitive position with surface transport."

With a maximum cruising speed of 500 miles per hour, the huge aircraft will have a range of 6,300 miles carrying 56 tons. It will do the job of five C-141s or twenty C-124s.

"In effect," General Estes says, "MAC, as the global airlift command of the Air Force, has become the key element in a far-reaching change in national policy: to a strategy of multiple options for flexible, measured response to any situation in the spectrum of war."

If the airlift support of the war in Vietnam is any indication, as long as the transport aircraft keep coming off the assembly line, the demands for airlift will be met.



Boeing C-135B Stratolifter is loaded at a U. S. airbase with supplies for Vietnam operations.

Lockheed C-5As are depicted in an operational scene in an artist's conception. A 60-foot Army scissors bridge launcher rolls from the visor nose opening, and two Army tanks sit side-by-side in the huge rear cargo area. This huge cargo plane will have a cruising speed of 500 miles per hour, will carry 56 tons across a 6,300-mile range.

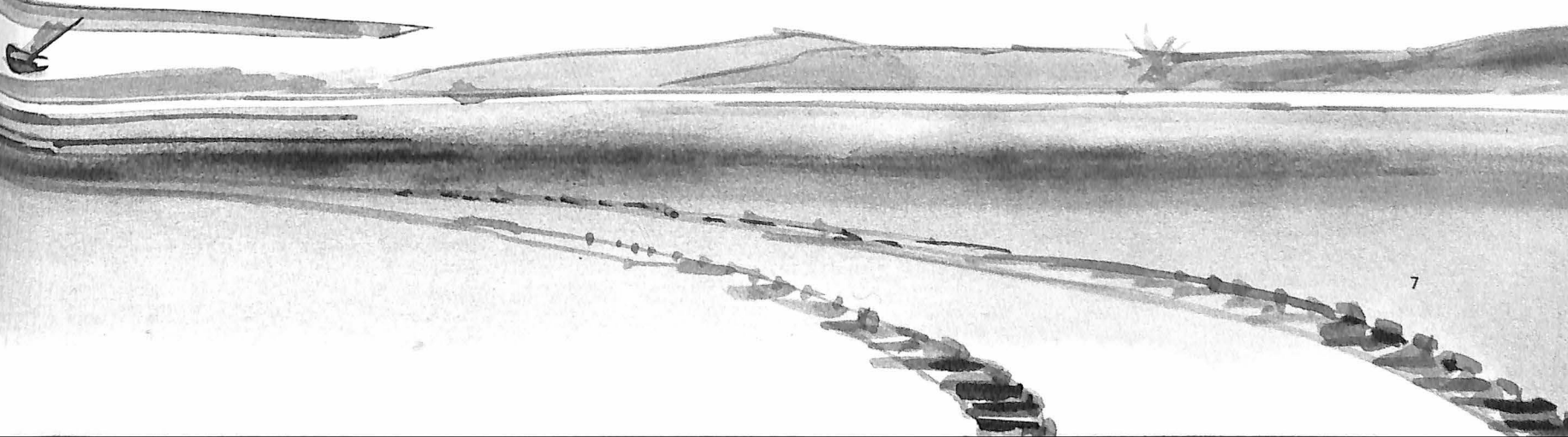

LTV Is Designing New Aircraft Propulsion Wing

Ling-Temco-Vought is designing a powered model of an aircraft with engines located inside the wings under a joint Air Force and Army contract.

Called the ADAM (Air Deflection and Modulation) propulsive wing, it features a unique integration of vertically-mounted high-bypass-ratio turbofan engines in the wing. The thrust from the turbofans can be deflected downward 100 degrees for use in vertical takeoff and landing.

The powered model will have a wing span of nearly five and one-quarter feet. The model will consist of a fuselage, propulsive wing, booms and tail. The wings will house four tip-turbine fans to simulate the propulsive systems.

Possible uses of the ADAM concept would be for an aircraft with a high subsonic strike-reconnaissance capability, and vertical takeoff and landing transport aircraft.

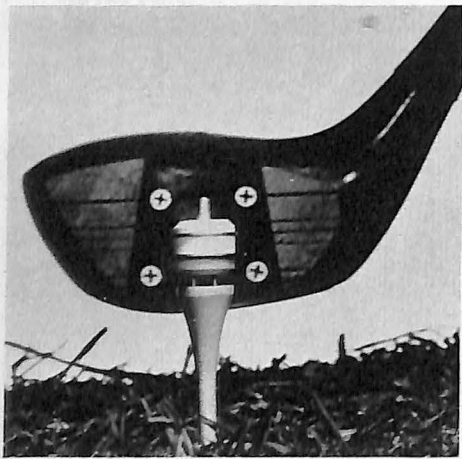

General Electric Tests Tube 2,000 Hours without Failure

General Electric has developed a new microminiature 7/8-inch metal-ceramic planar triode tube tested up to 2,000 hours without a failure. Normal warranty on such tubes is 500 hours.

Altitude, fatigue, shock, thermoshock, heater cycle life and variable vibration mechanical tests further attest to its ruggedness.

As a result of its tests, the tube is now recommended for use in fast-rise time-pulse generators, deflection amplifiers and grid pulse amplifier chains at low L-band for such applications as aircraft collision warning system and transponder equipment.



NAA Tests Underwater Sound Reflection Device

Initial sea tests have been completed on North American Aviation's transducer-reflector designed by NAA's Marine Systems Division at New London, Conn., to generate sounds underwater. The equipment consists of a five-foot parabolic reflector and a sound projector which were mounted on the bow of a two-man research submarine built by General Dynamics Electric Boat Division.

The device's curved hollow metal tubes form the parabolic reflecting surface, within which is mounted a rubber-covered, oil-filled sonar transducer at the reflector's focal point. The reflector directs the sound waves into a narrow searchlight-like beam.

Aboard the sub, maneuvering in both confined and open areas along the Continental Shelf and off the island of Bermuda, the sonar transducer sent out signals and measured the echoes during 100 hours of submerged test time.

Honeywell Laser Gyroscope Offers High Reliability

Honeywell Inc. has delivered to the Navy the first operational three-axis laser gyroscope which can more precisely sense a ship's roll, pitch and yaw which affect naval radar and gunfire.

Developed in only 12 months, the laser gyro is also the first of any type to

undergo flight test, the company said. It is designed to eliminate gyro drift by utilizing two intense beams of coherent light rotating in opposite directions to sense rotational motion.

The new gyro has no moving parts and potentially offers long operating life, high reliability, resistance to severe environmental conditions, wide dynamic range, and low cost.

Each axis of the gyro is built of a novel fused quartz block. The triangular path through which the helium-neon gas beams pass are machined by a special precision technique. Motion in one axis changes the apparent distance each beam must travel, causing a difference in the frequency at which each beam oscillates. The frequency difference is detected by two photocells and counted by associated electronic equipment.

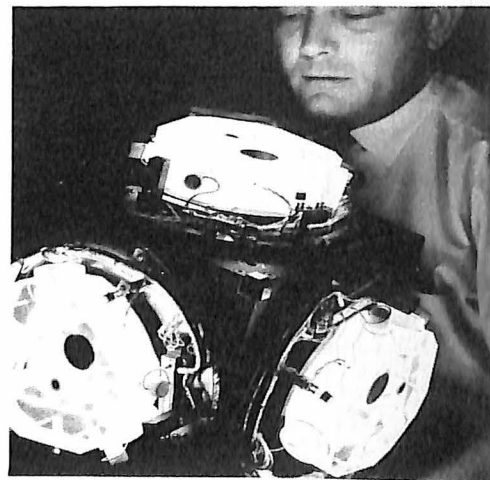

Sperry Develops Navigation Unit for Individual Soldiers

Sperry Rand's Gyroscope Division has developed a miniature radio navigation unit called Manpack Loran capable of giving a foot soldier an exact position fix by a matter of feet day or night and in any weather.

Manpack consists of a microcircuited receiver and battery carried on a back pack. A control indicator is worn on the belt of the user. Small rechargeable silver zinc batteries power the equipment. The receiver is equipped with a self-contained collapsible whip antenna. Without batteries, the unit weighs but seven pounds.

Range of the equipment varies between 400 and 1,000 miles. Its anti-jam capability is good, Sperry reports.

Mobility of the system provides tactical use on a world-wide basis. This development will bring Loran's proven accuracy to the man in the field, operating where vehicles cannot be used.

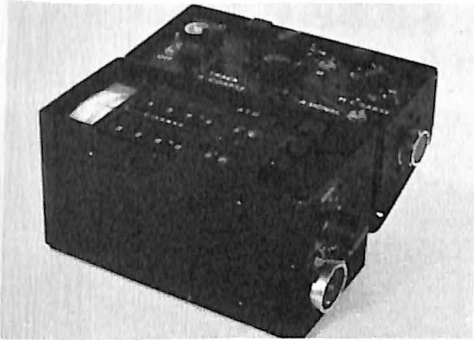

Hamilton Standard Tests Electron Beam Welder

United Aircraft's Hamilton Standard division has designed and successfully tested a hand-held electron beam welder which could be used for such extravehicular tasks as assembling space vehicle components.

The nine-pound portable welder has a beam power of 1½ kilowatts and can join titanium, aluminum and other metals up to one-quarter of an inch thickness. Designed to operate off a power supply on board a spacecraft, it measures 10 inches long and 3½ inches in diameter.

The welder's gun fires tightly packed electrons traveling 50,000 miles a second. It is held flat against the metal and rides along the weld seam on four tiny rollers. A shield around the mouth of the gun protects the operator against

splatter of molten metal and radiation. The welding is observed through two windows in the shield. The operator uses his little finger to squeeze the trigger that turns the beam on and off, minimizing chances of the powerful beam being turned on accidentally.

Because of the high speed and power of the electrons, little heat goes into the metal being welded which means the electron beam welder requires a smaller power supply than other methods of fusion welding.

RCA Delivers Long-range Warning Radar to USAF

A long-range, giant tracking radar to provide ultra-high-speed warning in event of ballistic missile attack has been delivered by Radio Corporation of America to the Ballistic Missile Early Warning System site at Clear, Alaska, where it will be operated by the U.S. Air Force.

It is housed in a 140-foot-diameter radome, made of paper, fiberglass and plastic. An 84-foot-diameter antenna inside weighs 270,000 pounds and other components of the radar include 156 cabinets of electronic equipment, five consoles, 415 power supplies, and 6,000 modular elements.

Shooting its beams through the protective radome, it will both detect and track missiles at ranges of thousands of miles. Upon detection of a target, the radar will "lock on" and track the target to determine if it is a hostile object. If so, it then will obtain accurate data on the object's trajectory and predict the area in which it will impact.

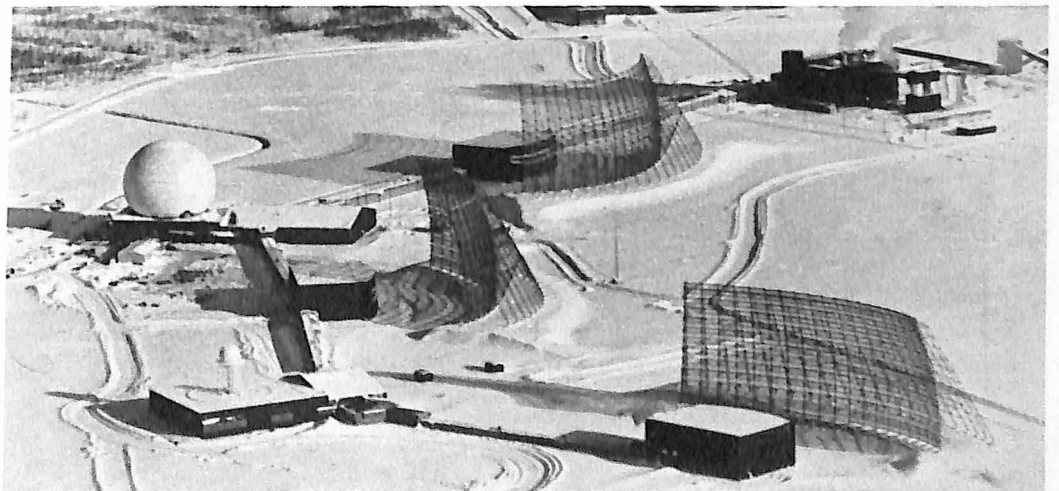

High Temperature Ceramics Investigated by Martin

Martin Company's Research Institute for Advanced Studies is investigating the fundamental properties of ceramics in order to develop materials that can withstand temperatures high enough to reduce most metals to a molten state while retaining great strength.

Ceramics of sufficient strength, oxidation resistant, and thermal shock re-

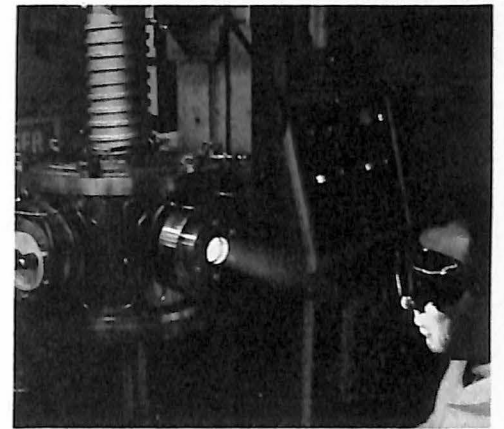

sistance are required in high-performance aircraft, space and nuclear systems as well as in lightweight, high strength materials for Army weapon systems.

Although the melting temperature of many ceramic materials far exceeds those of conventional metals, ceramics generally tend to be brittle, frequently sensitive to oxidation and sudden temperature changes and difficult to fabricate into structural components.

Part of the research work will entail adding minute quantities of boron to the ceramic materials to "lock" dislocations and decrease their mobility.



AEROSPACE





MEASUREMENTS - *Quest For Accuracy*



There was a time when the measurement of a yard was the distance between the tip of a British king's nose and the ends of his outstretched fingers. An inch was the thickness of a man's thumb whether a blacksmith or a minstrel. An acre was measured by the amount of ground a plowman and his ox could turn over in one day.

Industrial progress demanded a more systematic approach to measurement. Where once mass measurements ranging from an ounce to a ton were sufficient, today the mass of the earth and other celestial bodies are measured as well as the mass of an electron. Clock inaccuracies of a few seconds a day were tolerable in the last century. Today we keep time to an accuracy of one second in 30,000 years. Length inaccuracies used to be adequate if they were within a few thousands of an inch. Today we can measure within millionths of an inch.

Literally tens of billions of measurements are made in the United States every day — from checking the speedometer or gas gauge in an automobile to measurements involved in a complex instrument panel in a jet aircraft to the servomechanisms overseeing production and quality control in an aerospace factory or guiding a manned spacecraft flight.

Much of the change in measurement methods has developed in the past ten years because of the highly precise instrumentation required for aerospace products.

The Aerospace Industries Association's Quality Assurance Committee has a leading role in the new field

John T. Nelson, of the National Bureau of Standards, wrings gage blocks to a steel optical flat. The flat is placed into an interferometer and the lengths of the blocks are measured by light waves.

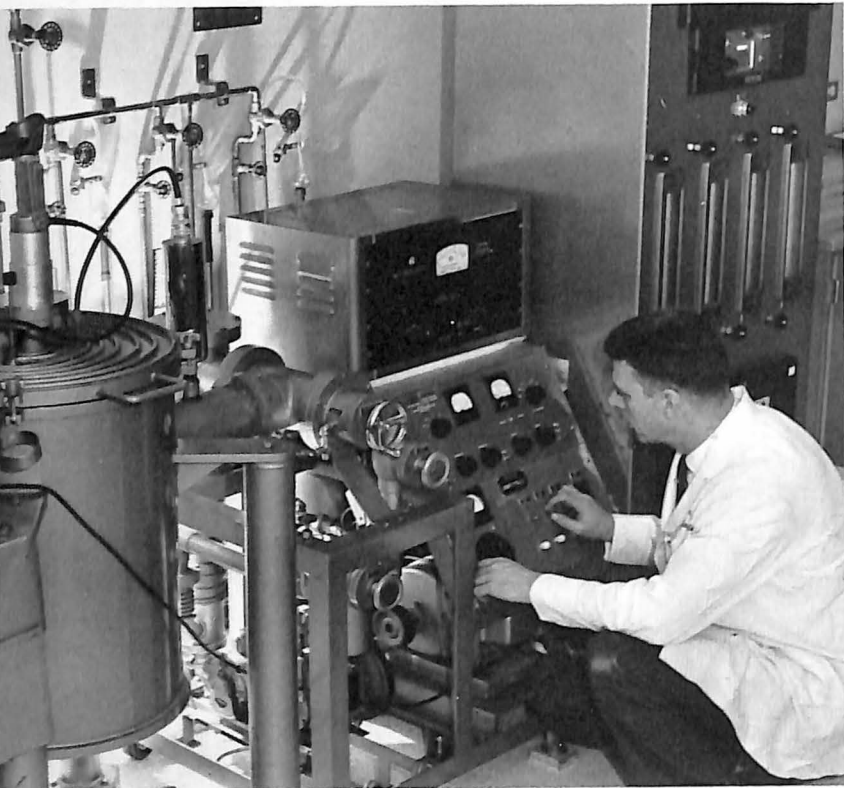

Thermocouples, sensitive temperature-measuring devices used in missile and aircraft testing, are checked for accuracy in a vacuum furnace at The Boeing Company's Primary Standards Metrology Laboratories. Aerospace companies have expanded greatly their standards operations.

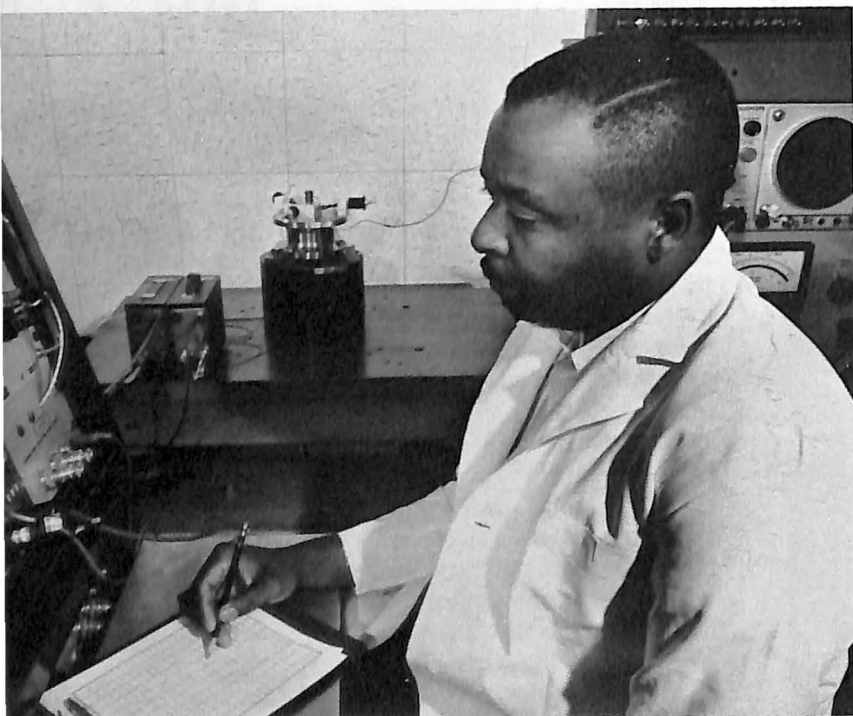

D. R. Bryant, of the NBS vibration laboratory, calibrates an accelerometer system using an electrodynamic exciter (center background).

of measurement science. In 1959 AIA in collaboration with the National Bureau of Standards and various military agencies completed an extensive "Industry Calibration Survey." The survey was prepared under the direction of Frank McGinnis, Sperry Gyroscope Company. The result was a report which showed the lagging state of our nation's ability to make measurements accurately enough to meet the challenge of the space age.

Out of this has come the establishment and continued operation of an NBS Advisory Committee on Calibration and Measurement Services. Under the sponsorship of the National Bureau of Standards, a National Conference of Standards Laboratories was formed in 1961 to provide a closer link with the industry standards laboratories and government standards laboratories in joint efforts to help solve measurement needs. Conferences were held in 1962, 1964 and 1966 in addition to a series of Standards Laboratory Management Workshops to improve the dissemination of information and through committee activities to devise solutions to specific problems.

Because of the extreme accuracies required in aerospace technology, ushering in a whole new spectrum of requirements, expanded ranges of measurements and completely new types of measurements, the continued cooperation of industry, the NBS and the various government agencies involved is mandatory.

The flight path for an inertially-guided missile is based upon the computation of an on-board computer. Any minor error in the computer during a 30-minute flight, for example, could become a significant one. On a moon flight lasting days, any such minor error could be a disabling one.

The inputs to the guidance computer are precise voltages. On manned space flights particularly, voltages must be accurate within very close tolerances.

The payload or carrying capacity of a spacecraft is limited by the thrust of its booster rockets. Each piece of equipment installed has to be as light as possible. In the case of radio transmitters, reduction of weight usually reduces the range. It is essential to know before the flight that the equipment will be able to transmit a usable signal back to earth during the mission. This can only be assured through the precise measurement of radio frequency, noise, field strength and how much the signal weakens.

In today's highly sophisticated aerospace industry another critical area is that of temperature. Questions requiring answers include: How fast will the surface of a particular alloy radiate heat? How fast does it conduct heat? All of these directly influence the final design of the spacecraft.

Accuracy in these areas is not alone relegated to space hardware. The pilot of a jet airliner must know his altitude, near sea level, to within plus or minus 20

feet. He also has to measure his location, air speed, time and distance to the airport. Maintenance people need to know how much longer the engine will stand up. They need to measure the state of engine wear.

Accuracy is everything. Aerospace companies maintain measurement standards laboratories which are traceable to those maintained by the National Bureau of Standards. Accurately calibrated tools are essential to make and assemble the hardware which has been designed. Calibrated test equipment is used to determine whether the hardware which has been manufactured meets quality and reliability specifications.

Since its creation in 1901, the National Bureau of Standards has been a primary center for government research and development in the physical sciences, especially as related to measurement science. It has also served science, technology and industry as the custodian of the primary measurement standards, through the development of measurement standards and techniques, by the measurement of materials properties and distribution of standard materials, through the development of technical background for new engineering standards, and the dissemination of information.

Originally the NBS was located in two buildings on an eight-acre site in northwest Washington. Through the years it had to expand its facilities to nearly 100 buildings. Eventually even these facilities became taxed by the increasing workload of the bureau and it moved its operations to a rural site in Gaithersburg, Maryland, removed from the mechanical, electrical and atmospheric disturbances of the city which had gradually encroached upon its original site in Washington.

Indicative of the scope of the nation's measurement system is the \$25 billion which the U. S. has invested in measuring instruments alone. Each year the instruments industry adds another \$4.5 billion to this total.

Much of the information necessary to make measurement-cost tradeoffs can be developed by making much more extensive use of the measurement comparison concept. Sometimes referred to as measurement agreement or "round robin" agreement, this concept is a systematic means of comparing measurements or calibrations made at two or more laboratories. It is a technique which provides positive, quantitative, cost effective indications of the measurement state-of-the-art relative to specification requirements for proved accuracies and ranges of measurement.

A national measurement system is as essential to the nation as are the national systems of communication, transportation and defense. In fact, these other national systems could not operate without the measurement basis provided by the National Bureau of Standards. It in turn depends on the other national systems as they all interact together to form the basis of our technology-oriented society.



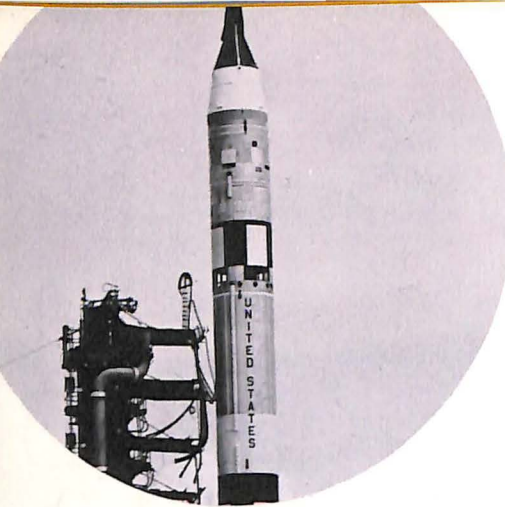

SPACE IN TEXAS

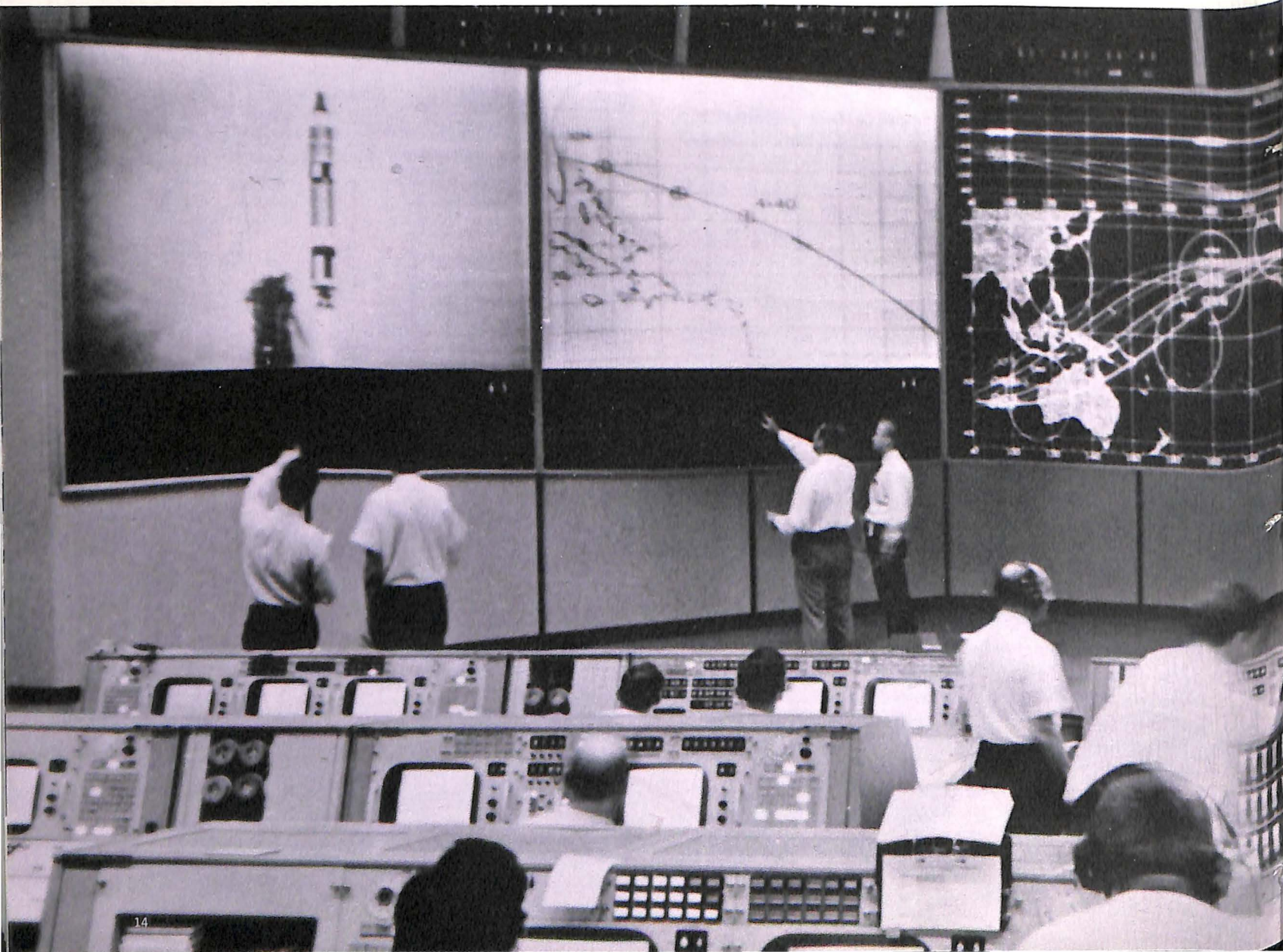

"This is Mission Control, Houston. Swim 1 reports the hatches on the spacecraft are open, the astronauts are fine and our clocks, here in the Control Center, indicate the time of the mission was 70 hours, 17 minutes and 54 seconds."

The voice comes from the Manned Spacecraft Center in Houston, Texas, as another manned space flight mission comes to a successful end.

Since the flight of Gemini V, in August 1965, the Manned Spacecraft Center (MSC) complex has controlled the flights of the Gemini program, and will carry over into the Apollo man-on-the-moon program and the programs after Apollo.

The hub of MSC is the Mission Control Center (MCC), but much of the preparation for coming missions revolves around Building 30 which houses Mission Operations and Operations Support.

On the ground floor of this key center are the Real Time Computer Complex (RTCC) and the Communications System. This complex was developed and is managed by the IBM Corporation. Installation of the system began in January 1963 and it was ready to monitor the unmanned GT-2 flight in November 1964. During the manned flights which followed, the complex

was checked out and began providing the second-by-second information so vital to flight controllers.

Today, its importance is underscored by the fact that more than 700 IBM employees are in constant attendance, feeding and receiving millions of items during a flight and reprogramming the complex between flights.

However, not only does the complex control flights in progress, it also plays the dual role of providing training capabilities for both astronauts and ground crews — even while a mission is underway.

It is here that mission operations teams keep their fingers on the pulse of the entire mission and the aerospace industry plays its greatest role at the Manned Spacecraft Center, both during and between missions.

Such companies as Philco's Aeronutronic Division spend thousands of man-hours between flights, assuring that the complex is as foolproof as possible before lift-off time.

Aeronutronic technicians, for example, begin preparing the center for the next mission almost as soon as splashdown occurs. Their task is to set up the center for the aims of the coming mission. This includes, among dozens of other tasks, such things as chang-

Missions Operations Control Room is the principal command and decision area in the Mission Control Center at Houston, Texas.

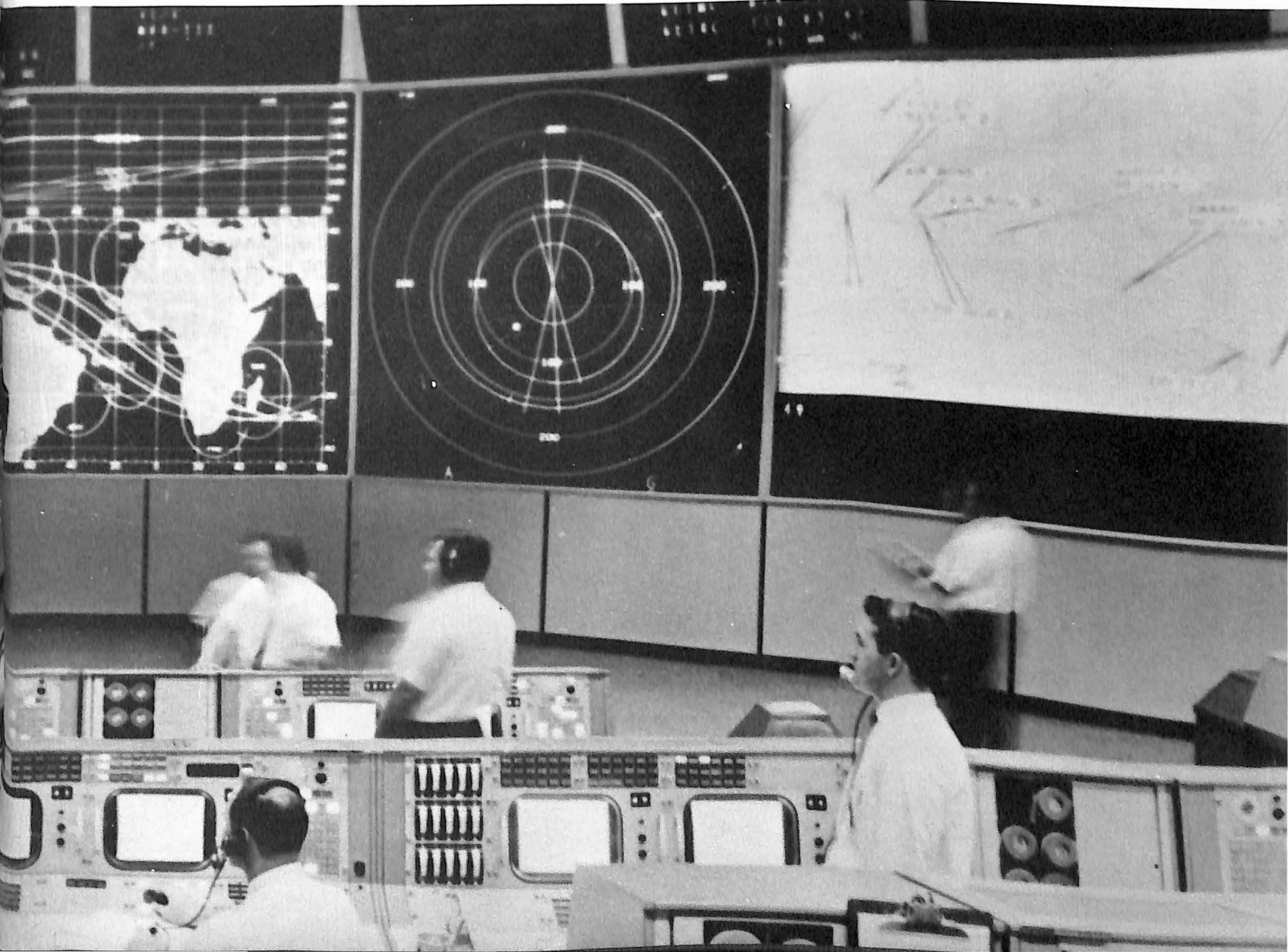

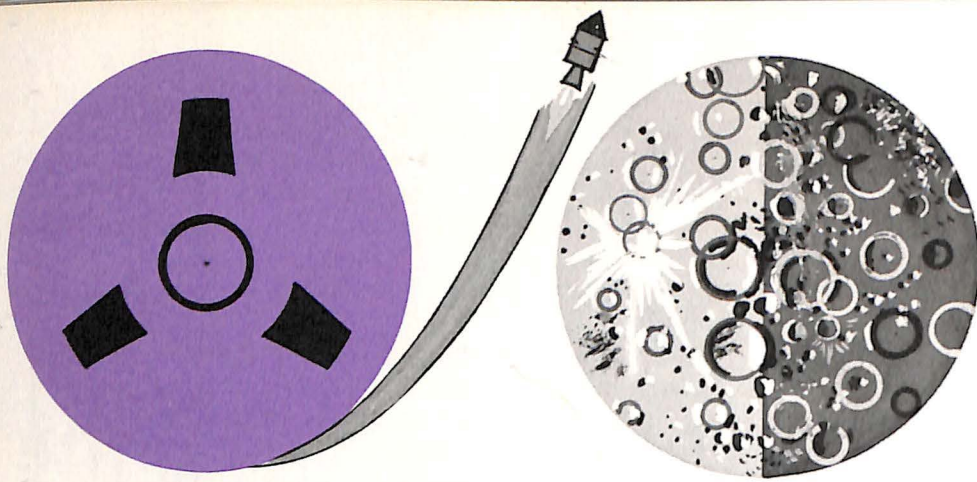

Aerospace companies will have a major role in the digital data processing during the Apollo program.

ing the connections of thousands of wires which will feed instant display information to controller teams.

Additionally, Aeronutronic has the responsibility for preparing, in advance, such things as slides for the many displays that are used at every console and include such items as world map and recovery area projections.

This type of material is used for "mixing" with that supplied through IBM's efforts. The results of the comparisons show the degree of nominal operations being achieved — or any deviation — during any event of the mission. The operation is called video-mixing.

Aeronutronic's responsibility for preparation of the consoles continues right up to the start of the many simulated runs that fill the last few days before a mission lifts off. Additionally, along with other contractor representatives for all the maze of equipment necessary during a flight, their representatives remain close at hand during missions to assure that expert advice is readily available, should it be needed.

Most of these representatives are not actually on the floor, but remain in the Staff Support Rooms — following the mission's progress, ticking off the functions, checking out isolated malfunctions and seeking solutions which are fed to the mission control team.

Largely unseen and mostly unheralded, because of the efficiency and reliability of the equipment they supervise, these men provide the back-up — or, a favorite space flight word, redundancy — which assures the safety of the astronauts in orbit.

It would be virtually impossible to list all the many technicians housed in these staff support rooms but, as an example, they represent such firms as the Martin Company, builder of the Gemini launch vehicle; General Dynamics, the prime contractor for Atlas boosters; McDonnell Company, Lockheed Aircraft Corp., and the dozens of other key contributors that make manned spaceflight possible.

As Gemini phases out and Apollo begins to move to center stage, some of these key operational chairs will see new faces moving in, but the operation itself will change little.

For example, TRW Inc., which has played a key role during the Gemini program, will continue its efforts in the Apollo program. TRW is responsible, for instance, for the mission trajectory control programs for both

Gemini and Apollo. Additionally, TRW will operate the Apollo Systems Analyses Program.

Not all operations performed by the aerospace industry in Houston are limited to flights and preparation for flights. For example, TRW will also take a major part in processing experimental data collected by instruments on the moon, plus studies on ablative materials, microelectronic circuitry and digital data processing during the Apollo program.

As the Apollo manned program draws nearer, North American Aviation's role is increasing in importance. As prime contractor for the Apollo spacecraft, NAA has already assumed a major testing function on the site. The thermo-vacuum testing of the spacecraft was recently completed and all of the test group were NAA personnel, including the console operators.

As Apollo reaches farther into space, other companies begin to gain in prominence. For example, when the first astronauts set foot on the moon's surface, they will be carried there aboard the Lunar Module, a product of the Grumman Aircraft Engineering Corporation. Other key contractor roles are also expanding as new equipment arrives.

The aerospace industry is represented by nearly 7,000 engineers and technicians in the immediate vicinity of the Manned Spacecraft Center.

Nearly 500 companies are represented with permanent staffs at the center and this has led to a building program, outside the NASA installation, which rivals the multi-million dollar government investment.

Buildings designed to blend with the center's structural style have been erected nearby which house most of the smaller staffs, as well as the employees of such major companies as General Electric and Grumman.

This community has become a tight, almost friction-free bloc that works together and plays together. Its financial contribution to the Houston area has been significant and the end is not yet in sight.

As Gemini phases out and Apollo begins, plans continue for exploration beyond the moon and the center continues to grow. The thousands of local employees — government, industrial and military — who derive their living from space, see that pioneering effort going on for additional decades and view their operations as the pulse of that effort.

AIA
MANUFACTURING
MEMBERS

Abex Corporation
Aerodex, Inc.
Aerojet-General Corporation
Aeronca, Inc.
Aeronutronic Division, Philco Corporation
Aluminum Company of America
Avco Corporation
Beech Aircraft Corporation
Bell Aerospace Corporation
The Bendix Corporation
The Boeing Company
Cessna Aircraft Company
Chandler Evans, Inc.
Control Systems Division of
Colt Industries, Inc.
Continental Motors Corporation
Cook Electric Company
Curtiss-Wright Corporation
Douglas Aircraft Company, Inc.
Fairchild Hiller Corporation
The Garrett Corporation
General Dynamics Corporation
General Electric Company
Defense Electronics Division
Flight Propulsion Division
Missile & Space Division
Defense Programs Division
General Laboratory Associates, Inc.
General Motors Corporation
Allison Division
General Precision, Inc.
The B. F. Goodrich Company
Goodyear Aerospace Corporation
Grumman Aircraft Engineering Corp.
Gyrodyne Company of America, Inc.
Harvey Aluminum, Inc.
Hercules Incorporated
Honeywell Inc.
Hughes Aircraft Company
IBM Corporation
Federal Systems Division
International Telephone & Telegraph Corp.
ITT Federal Laboratories
ITT Gilfillan, Inc.
Kaiser Aerospace & Electronics Corporation
Kaman Aircraft Corporation
Kollsman Instrument Corporation
Lear Jet Industries, Inc.
Lear Siegler, Inc.
Ling-Temco-Vought, Inc.
Lockheed Aircraft Corporation
The Marquardt Corporation
Martin Company
McDonnell Company
Menasco Manufacturing Company
North American Aviation, Inc.
Northrop Corporation
Pacific Airmotive Corporation
Piper Aircraft Corporation
PneumoDynamics Corporation
Radio Corporation of America
Defense Electronic Products
Rockwell-Standard Corp.
Aircraft Divisions
Rohr Corporation
Ryan Aeronautical Company
Solar, Division of International
Harvester Co.
Sperry Rand Corporation
Sperry Gyroscope Company
Sperry Phoenix Company
Vickers, Inc.
Sundstrand Aviation, Division of
Sundstrand Corporation
Thiokol Chemical Corporation
TRW Inc.
United Aircraft Corporation
Westinghouse Electric Corporation
Aerospace Electrical Division
Aerospace Division
Astronuclear Laboratory
Marine Division

Heights can be measured to 20 millionths of an inch with this optical electronic sight at The Boeing Company's Primary Standards Metrology Laboratories. (See *Aerospace Measurements—Quest For Accuracy*, page 10.)



